

### Editors-in-Chiefs

**Chun-Yen CHANG**, National Taiwan Normal University (NTNU), TAIWAN

**Lianghuo FAN**, University of Southampton, UNITED KINGDOM

**Milan KUBIATKO**, University of Zilina, SLOVAKIA

### Editors

Len ANNETTA, *East Carolina University, USA*  
Pierre COLLET, *University of Strasbourg, FRANCE*  
Kwok Cheung CHEUNG, *University of Macau, MACAU*  
Oh Nam KWON, *Seoul National University, SOUTH KOREA*  
Yew Hoong LEONG, *Nanyang Technological University, SINGAPORE*  
Xiufeng LIU, *Graduate School of Education, University at Buffalo, USA*  
Jing LIN, *Beijing Normal University, CHINA*  
Silvija MARKIC, *University of Education Ludwigsburg, GERMANY*  
Teen-Hang MEEN, *National Formosa University, TAIWAN*  
Jan Alexis NIELSEN, *University of Copenhagen, DENMARK*  
Mariusz PANCZYK, *Medical University of Warsaw, POLAND*  
Tali TAL, *Technion - Israel Institute of Technology, ISRAEL*  
Chunxia QI, *Beijing Normal University, CHINA*  
Tzu-Hua WANG, *National Tsing Hua University, TAIWAN (R.O.C.)*  
Der-Ching YANG, *National Chiayi University, TAIWAN*  
Zacharia ZACHARIAS, *University of Cyprus, CYPRUS*

### Assistant Editors

Jana FANCOVICOVA, *University of Trnava, SLOVAKIA*,  
E-mail: [fankaj@gmail.com](mailto:fankaj@gmail.com)  
Vanda JANSTOVA, *Charles University, Prague, CZECH REPUBLIC*,  
E-mail: [vanda.janstova@natur.cuni.cz](mailto:vanda.janstova@natur.cuni.cz)

### Editorial Board

Fouad ABD-EL-KHALICK, *University of Illinois at Urbana-Champaign, USA*  
Agustin ADÚRIZ-BRAVO, *Universidad de Buenos Aires, ARGENTINA*  
Maria Pilar Jiménez ALEIXANDRE, *Universidade de Santiago de Compostela, SPAIN*  
Michael ALLEN, *Kingston University, UK*  
Kyriacos ATHANASIOU, *National and Kapodistrian University of Athens, GREECE*  
Alipaşa AYAS, *Bilkent Üniversitesi, TURKEY*  
Nélio BIZZO, *Universidade de São Paulo, BRAZIL*  
Saouma BOUJAOUDE, *American University of Beirut, LEBANON*

Lynn A. BRYAN, *Purdue University, USA*  
Peter C. CORMAS, *California University of Pennsylvania, USA*  
Colleen T. DOWNS, *University of KwaZulu-Natal, SOUTH AFRICA*  
Jan H. VAN DRIEL, *University of Melbourne, AUSTRALIA*  
Ingo EILKS, *University of Bremen, GERMANY*  
Lyn ENGLISH, *Queensland University of Technology, AUSTRALIA*  
Olle ESKILSSON, *Kristianstad University, SWEDEN*  
Uwe GELLERT, *Freie Berlin University, GERMANY*  
Anjum HALAI, *Aga Khan University, PAKISTAN*  
Gürol IRZİK, *Sabancı Üniversitesi, TURKEY*  
Gert KADUNZ, *University of Klagenfurt, AUSTRIA*  
Marika KAPANADZE, *Ilia State University, GEORGIA*  
Gregory J. KELLY, *The Pennsylvania State University, USA*  
Vanessa KIND, *Durham University, UK*  
Vincentas LAMANAUSKAS, *University of Siauliai, LITHUANIA*  
Jari LAVONEN, *University of Helsinki, FINLAND*  
Norman G. LEDERMAN, *Illinois Institute of Technology, USA*  
Rachel MAMLOK-NAAMAN, *Weizmann Institute of Science, ISRAEL*  
Sonya N. MARTIN, *Seoul National University, REPUBLIC OF KOREA*  
Mansoor NIAZ, *Universidad de Oriente, VENEZUELA*  
Pernilla NILSSON, *Halmstad University, SWEDEN*  
Rolf V. OLSEN, *University of Oslo, NORWAY*  
Kamisah OSMAN, *Universiti Kebangsaan Malaysia, MALAYSIA*  
Paul PACE, *University of Malta, MALTA*  
Pavol PROKOP, *Trnava University, SLOVAKIA*  
Sarrantos PSYCHARIS, *School of Pedagogical and Technological Education - ASPETE, GREECE*  
Martin RUSEK, *Charles University, CZECH REPUBLIC*  
Rohaida Mohd. SAAT, *University of Malaya, MALAYSIA*  
Chieh-Jen SHIEH, *Huaqiao University, CHINA*  
Kenneth TOBIN, *The Graduate Center of CUNY, USA*  
Chin-Chung TSAI, *National Chiao Tung University, TAIWAN*  
Charis VOUTSINA, *University of Southampton, UNITED KINGDOM*  
Lung Hsiang WONG, *Nanyang Technological University, SINGAPORE*

**The Eurasia Journal of Mathematics, Science and Technology Education (EJMSTE)** is an academic journal devoted to the publication and dissemination of research and position articles on all aspects of mathematics, science, engineering, health, medical education and technology education. All articles are reviewed by the members of the editorial board which consists of internationally respected educators, researchers, and practitioners.

**Submissions:** EJMSTE has a fully online review system. This system offers authors the convenience of submitting their manuscripts via **ScholarOne** and **EditorialSystem**. Please send your manuscripts as an MS Word attachment to the editors via the following addresses:

<https://mc04.manuscriptcentral.com/eurasia>

<https://www.editorialsystem.com/ejmste/>

Eurasia Journal of Mathematics, Science and Technology Education (EJMSTE) is a monthly journal published online 12 times annually in **January, February, March, April, May, June, July, August, September, October, November, and December**.

EJMSTE is indexed and/or abstracted in **Cabell's Directory Index, EBSCO, SSCI® - Social Science Citation Index, SCOPUS, ERIC - Education Resources Information Center, PsycINFO, Current Contents - Social & Behavioral Sciences, EdNA Online Database, Education Research Index, Google Scholar, Higher Education Teaching and Learning Journals, Higher Education Research Data Collection, Index Copernicus, JournalSeek, MathDi, TOC Premier Database, Ulrich's Periodicals Directory and ZDB - Zeitschriftendatenbank**.

Publication of any material submitted by authors does not necessarily mean that the journal, publisher, editors, or any of the editorial board members endorse or suggest the content. Publishing decisions are based and given only on scholarly evaluations. Apart from that, decisions and responsibility for adopting or using partly or in whole any of the methods, ideas or the like presented in EJMSTE pages solely depends on the readers' own judgment.

Published by: **MODESTUM LIMITED**

Publication Office: Suite 124 Challenge House

616 Mitcham Road, CRO 3AA, Croydon,

London, UK Phone: + 44 (0) 208 936 7681

Email: [publications@modestum.co.uk](mailto:publications@modestum.co.uk)

Publisher: <http://modestum.co.uk>

Journal Web: <http://www.ejmste.com>

Twitter: <https://twitter.com/ejmste>

Facebook: <https://www.facebook.com/ejmste>



**Challenge House Business Centre**

© 2005-2018. All rights reserved by Modestum Limited. Copyright for Open Access Content is Retained by Authors. Also, authors continue to hold the copyrights of their own papers by acknowledging that their papers are originally published in the EURASIA J Math, Sci & Tech Ed. Hence, articles published are licensed under a **“Creative Commons Attribution 4.0 International License.”**

ISSN 1305 - 8223

## VOLUME 14 ISSUE 6 CONTENTS (JUNE 2018)

<b>Mobile Virtual Reality as an Educational Platform: A Pilot Study on the Impact of Immersion and Positive Emotion Induction in the Learning Process</b>	2045–2057
Elena Olmos-Raya, Janaina Ferreira-Cavalcanti, Manuel Contero, M. Concepción Castellanos, Irene Alice Chicchi Giglioli, Mariano Alcañiz <a href="https://doi.org/10.29333/ejmste/85874">https://doi.org/10.29333/ejmste/85874</a>	
<b>Analysis of the Learning Effectiveness of Atayal Culture CPS Spatial Concept Course on Indigenous Students</b>	2059–2066
Jenyi Chao, Chuan-Hsi Liu, Yi-Hsin Yeh <a href="https://doi.org/10.29333/ejmste/86162">https://doi.org/10.29333/ejmste/86162</a>	
<b>How do College Students Clarify Five Sample Spaces for Bertrand’s Chord Problem?</b>	2067–2079
Bongju Lee, Yong Sik Yun <a href="https://doi.org/10.29333/ejmste/86163">https://doi.org/10.29333/ejmste/86163</a>	
<b>Aims for Learning 21st Century Competencies in National Primary Science Curricula in China and Finland</b>	2081–2095
Yan Wang, Jari Lavonen, Kirsi Tirri <a href="https://doi.org/10.29333/ejmste/86363">https://doi.org/10.29333/ejmste/86363</a>	
<b>The Necessary Knowledge for Online Education: Teaching and Learning to Produce Knowledge</b>	2097–2106
Jacques Ferreira, Marilda Behrens, Patricia Torres, Rita Marriott <a href="https://doi.org/10.29333/ejmste/86463">https://doi.org/10.29333/ejmste/86463</a>	
<b>Designing a System for English Evaluation and Teaching Devices: A PZB and TAM Model Analysis</b>	2107–2119
Paul Juinn Bing Tan, Ming-Hung Hsu <a href="https://doi.org/10.29333/ejmste/86467">https://doi.org/10.29333/ejmste/86467</a>	
<b>Improving the Basics of GIS Students’ Specialism by Means of Application of ESDA Method</b>	2121–2132
Shiliang Zhang, Dejing Lin, Tingcheng Chang <a href="https://doi.org/10.29333/ejmste/86468">https://doi.org/10.29333/ejmste/86468</a>	
<b>Modular Curriculum Designed for the Environmental Education of 6<sup>th</sup> and 7<sup>th</sup> Grade Students in the North Cyprus</b>	2133–2143
Şerife Gündüz, Gülsüm Aşıksoy, Umut Öksüz <a href="https://doi.org/10.29333/ejmste/85312">https://doi.org/10.29333/ejmste/85312</a>	
<b>Understanding Students Ideas about Animal Classification</b>	2145–2155
Zofia Anna Chyleńska, Eliza Rybska <a href="https://doi.org/10.29333/ejmste/86612">https://doi.org/10.29333/ejmste/86612</a>	
<b>The Effects of Creative Drama Teaching Methods on Academic Success in Architectural Education</b>	2157–2167
Hare Kılıçaslan, Serbüilent Vural <a href="https://doi.org/10.29333/ejmste/86613">https://doi.org/10.29333/ejmste/86613</a>	
<b>The Rising of Green Society: Low-Carbon Consumption as a Result of Environmental Education in China</b>	2169–2183
Lie’en Weng, Shuigen Hu, Zhujun Tao, Jingrui Xu <a href="https://doi.org/10.29333/ejmste/85939">https://doi.org/10.29333/ejmste/85939</a>	
<b>Application of Engineering Education in Entrepreneurship Construction System</b>	2185–2191
Yan-Ming Cheng, Kai Wang, Il-Kyoo Lee <a href="https://doi.org/10.29333/ejmste/86963">https://doi.org/10.29333/ejmste/86963</a>	
<b>The Relationship between Learning Orientation and Dynamic Capability based on Environmental Education</b>	2193–2202
Xin He, Shi-Zheng Huang, Kou Zhao, Xia Wu <a href="https://doi.org/10.29333/ejmste/85938">https://doi.org/10.29333/ejmste/85938</a>	
<b>A Study on Lacquer Design Teaching via Digital Platform</b>	2203–2211
Kuo-Kuang Fan, Xue-Hui Li, Meng-Jia Lu <a href="https://doi.org/10.29333/ejmste/86993">https://doi.org/10.29333/ejmste/86993</a>	

- Effects of Digital Flipped Classroom Teaching Method Integrated Cooperative Learning Model on Learning Motivation and Outcome** 2213–2220  
Jian Qiang  
<https://doi.org/10.29333/ejmste/86130>
- An Efficient Approach to Slicing Learning Video to Improve Learning Effectiveness by Considering Learner Prior Knowledge** 2221–2232  
Chien-I Lee, Chang-Lin Tsai  
<https://doi.org/10.29333/ejmste/87018>
- Study of Continuing Medical Education, Job Stress and Sleep Quality in Health and Medicine Industry – The Impact Relatedness** 2233–2240  
Yu-Zhou Luo, Zhao-Yan Hu, Fang Xu, Rui Wang  
<https://doi.org/10.29333/ejmste/85940>
- Assessing the Impact of Technology Learning and Assessment Method on Academic Performance: Review Paper** 2241–2254  
Ragad M. Tawafak, Awanis BT Romli, Ruzaini bin Abdullah Arshah, Rana A. Saeed Almaroof  
<https://doi.org/10.29333/ejmste/87117>
- Applying Virtual Reality to Study the Effects of Environmental Education on College Students’ Ethics and Environmental Literacy** 2255–2263  
Qiong Liu, Dafeng Gong, Min Chen  
<https://doi.org/10.29333/ejmste/85937>
- Why do Plants Wilt? Investigating Students’ Understanding of Water Balance in Plants with External Representations at the Macroscopic and Submicroscopic Levels** 2265–2276  
Gregor Torkar, Manja Veldin, Saša Aleksej Glažar, Anja Podlesek  
<https://doi.org/10.29333/ejmste/87119>
- Study of the Effect of Environmental Education on Environmental Awareness and Environmental Attitude Based on Environmental Protection Law of the People’s Republic of China** 2277–2285  
Yang Li  
<https://doi.org/10.29333/ejmste/86214>
- Contextualizing the EU’s “Responsible Research and Innovation” Policy in Science Education: A Conceptual Comparison with the Nature of Science Concept and Practical Examples** 2287–2300  
Antti Laherto, Lorenz Kampschulte, Miikka de Vocht, Ron Blonder, Sevil Akaygun, Jan Apotheker  
<https://doi.org/10.29333/ejmste/89513>
- Application of the Complementarities of Two Theories, APOS and OSA, for the Analysis of the University Students’ Understanding on the Graph of the Function and its Derivative** 2301–2315  
Vahid Borji, Vicenç Font, Hassan Alamolhodaie, Alicia Sánchez  
<https://doi.org/10.29333/ejmste/89514>
- Effects of Learning Styles and Locus of Control on the Decision-Making Styles of Leader Managers** 2317–2328  
Salim Akyürek, Salih Guney  
<https://doi.org/10.29333/ejmste/89515>
- Examining the Differences between the Job Satisfaction of STEM and Non-STEM Novice Teachers with Leaving Intentions** 2329–2341  
Ke Wang, Zhuo Chen, Wen Luo, Yeping Li, Hersh Waxman  
<https://doi.org/10.29333/ejmste/89516>
- Training of Future Technology Teachers: Management Tools and Challenges in Current Educational Process** 2343–2351  
Olga Shatunova, Elena Merzon, Milyausha Shaimardanova, Sergey Shabalin  
<https://doi.org/10.29333/ejmste/89559>
- The Impacts of Teacher’s Efficacy and Motivation on Student’s Academic Achievement in Science Education among Secondary and High School Students** 2353–2366  
Seçil Bal-Taştan, Seyed Mehdi Mousavi Davoudi, Alfiya R. Masalimova, Alexandr S. Bersanov, Rashad A. Kurbanov, Anna V. Boiarchuk, Andrey A. Pavlushin  
<https://doi.org/10.29333/ejmste/89579>



<b>STEM Education in English of Early Childhood in China</b> Wenxiao Zhao <a href="https://doi.org/10.29333/ejmste/89596">https://doi.org/10.29333/ejmste/89596</a>	2367–2378
<b>Monitoring of the Educational Process with the Use of Information and Communication Technologies: A Case Study in Computer Science</b> Natalia Barinova, Venera Zakirova, Daniya Akhmetova, Lyudmila Lysogorova <a href="https://doi.org/10.29333/ejmste/89840">https://doi.org/10.29333/ejmste/89840</a>	2379–2391
<b>Promoting Education Equity in Rural and Underdeveloped Areas: Cases on Computer-Supported Collaborative Teaching in China</b> Harrison Hao Yang, Sha Zhu, Jason MacLeod <a href="https://doi.org/10.29333/ejmste/89841">https://doi.org/10.29333/ejmste/89841</a>	2393–2405
<b>Teachers' Transformed Subject Matter Knowledge Structures of the Doppler Effect</b> Mpho Mosabala <a href="https://doi.org/10.29333/ejmste/89842">https://doi.org/10.29333/ejmste/89842</a>	2407–2417
<b>Based on Statistical Education to Study Innovative Service and Relationship Quality of University Library under Big Data</b> Ruiyi Gong, Kaijun Yu, Hongmei Tang <a href="https://doi.org/10.29333/ejmste/89499">https://doi.org/10.29333/ejmste/89499</a>	2419–2425
<b>Didactic Value of Gamification Tools for Teaching Modeling as a Method of Learning and Cognitive Activity at School</b> Elena V. Soboleva, Elvira G. Galimova, Zhumagul A. Maydangalieva, Khalimat Khadzhi-M. Batchayeva <a href="https://doi.org/10.29333/ejmste/89843">https://doi.org/10.29333/ejmste/89843</a>	2427–2444
<b>A Study of the Effect of Implementing Intellectual Property Education with Digital Teaching on Learning Motivation and Achievements</b> Aimin Qi <a href="https://doi.org/10.29333/ejmste/89498">https://doi.org/10.29333/ejmste/89498</a>	2445–2452
<b>Investigating the Effects of Flipped Learning, Student Question Generation, and Instant Response Technologies on Students' Learning Motivation, Attitudes, and Engagement: A Structural Equation Modeling</b> Chien-Yuan Su, Cheng-Huan Chen <a href="https://doi.org/10.29333/ejmste/89938">https://doi.org/10.29333/ejmste/89938</a>	2453–2466
<b>Discussing the Effect of Service Innovation on Customer Satisfaction Based on Statistics Education – A Case on Qianjiangyue Leisure Farm</b> Shui-Sheng Fan, You-Cheng Chen, Lu Miao <a href="https://doi.org/10.29333/ejmste/89530">https://doi.org/10.29333/ejmste/89530</a>	2467–2474
<b>Integration of Project Activity to Enhance the Scientific Process Skill and Self-Efficacy in Zoology of Vertebrate Teaching and Learning</b> Diana Hernawati, Mohamad Amin, Mimien Irawati, Sri Indriwati, Muhammad Aziz <a href="https://doi.org/10.29333/ejmste/89940">https://doi.org/10.29333/ejmste/89940</a>	2475–2485
<b>A Study on College Students' Psychology of Revenge and Interpersonal Forgiveness and the Relationship with Health Education</b> Zhi-Yong Zhuang, Wei Qiao <a href="https://doi.org/10.29333/ejmste/89517">https://doi.org/10.29333/ejmste/89517</a>	2487–2492
<b>Development of a Remote Laboratory Infrastructure and LMS for Mechatronics Distance Education</b> Ayça Ak, Vedat Topuz, Aysun Altıkardes, Bekir Oral <a href="https://doi.org/10.29333/ejmste/89947">https://doi.org/10.29333/ejmste/89947</a>	2493–2508
<b>The Impact of Adopting Web 2.0-Based E-Book on Student Learning Skills</b> Hatim Ibrahim, Abdullah Saad H Alqahtani <a href="https://doi.org/10.29333/ejmste/90085">https://doi.org/10.29333/ejmste/90085</a>	2509–2522
<b>Use of Tangible Materials and Computer in Mathematics Teaching: Opinions of School Principals</b> Sait Akbaşlı, İlknur Yeşilce <a href="https://doi.org/10.29333/ejmste/90087">https://doi.org/10.29333/ejmste/90087</a>	2523–2532

<b>Efficiency Evaluation and Influencing Factors Analysis of Governmental Expenditure on Preschool Education</b>	2533–2543
Bin Tu, Ying-Xian Lin, Yi-Meng Zhang <a href="https://doi.org/10.29333/ejmste/89775">https://doi.org/10.29333/ejmste/89775</a>	
<b>The Effects of Watching Authentic English Videos with and without Subtitles on Listening and Reading Skills of EFL Learners</b>	2545–2553
Rastislav Metruk <a href="https://doi.org/10.29333/ejmste/90088">https://doi.org/10.29333/ejmste/90088</a>	
<b>Effects of Changed School Entry Rules: Age Effects within Third Grade Students</b>	2555–2562
Özgür Öner, Öykü Çalışır, Nazife Ayyıldız, İpek Çelikağ, Pınar Uran, Sinan Olkun, Metehan Çiçek <a href="https://doi.org/10.29333/ejmste/90089">https://doi.org/10.29333/ejmste/90089</a>	
<b>Naïve Designers’ Information Use during the Design Process in a Low-Resource Classroom</b>	2563–2586
Nicolaas Blom, Grietje Haupt, William Fraser <a href="https://doi.org/10.29333/ejmste/90091">https://doi.org/10.29333/ejmste/90091</a>	
<b>Research into the Effects of an ICALL Program on Teaching Word Classes to Learners of English</b>	2587–2598
Rüya Mert Altıncı, Behbood Mohammadzadeh <a href="https://doi.org/10.29333/ejmste/90093">https://doi.org/10.29333/ejmste/90093</a>	
<b>Compilation of the Scale of College Students’ Attitudes towards Three-self-determination PE Class and Norm Construction</b>	2599–2608
Yiyong Wu, Rong Hai Su <a href="https://doi.org/10.29333/ejmste/89776">https://doi.org/10.29333/ejmste/89776</a>	
<b>Effects of Social and Emotional Learning on Disadvantaged Year 1 Pupils’ Understanding of Sinking and Floating Concepts</b>	2609–2622
Ang Sze Wei, Mageswary Karpudewan <a href="https://doi.org/10.29333/ejmste/90258">https://doi.org/10.29333/ejmste/90258</a>	
<b>A New Mental Experience Quantification and Emotion Prediction Model for E-Learning Users</b>	2623–2638
Hui Wang, Ting-Cheng Chang <a href="https://doi.org/10.29333/ejmste/90259">https://doi.org/10.29333/ejmste/90259</a>	
<b>An Analysis Study of the Feasibility on Offering Bachelor’s Degree in Service Science</b>	2639–2652
Amer Al-Badarneh, James Spohrer, Basheer Al-Duwairi, Mohammed Shatnawi <a href="https://doi.org/10.29333/ejmste/90260">https://doi.org/10.29333/ejmste/90260</a>	
<b>Influence of Instructional Design to Manage Intrinsic Cognitive Load on Learning Effectiveness</b>	2653–2668
Yi-Hung Huang <a href="https://doi.org/10.29333/ejmste/90264">https://doi.org/10.29333/ejmste/90264</a>	
<b>How do Students Perceived Computerized Feedback as Effective?</b>	2669–2682
Chin Sook Fui, Lim Hooi Lian <a href="https://doi.org/10.29333/ejmste/90265">https://doi.org/10.29333/ejmste/90265</a>	
<b>The Depression and Creativity of Design-Major Students</b>	2683–2691
Eva Chang, Rain Chen <a href="https://doi.org/10.29333/ejmste/90266">https://doi.org/10.29333/ejmste/90266</a>	
<b>Comparison of Science and Engineering Concepts in Next Generation Science Standards with Jordan Science Standards</b>	2693–2709
Ahmad Qablan <a href="https://doi.org/10.29333/ejmste/90267">https://doi.org/10.29333/ejmste/90267</a>	
<b>Online Model for Teaching and Learning the Specialized Translation</b>	2711–2717
Nataliya Gavrilenko <a href="https://doi.org/10.29333/ejmste/85421">https://doi.org/10.29333/ejmste/85421</a>	
<b>Chinese College English Teachers’ Ability to Develop Students’ Informationized Learning in the Era of Big Data: Status and Suggestions</b>	2719–2728
Guo-Rong Shen <a href="https://doi.org/10.29333/ejmste/90554">https://doi.org/10.29333/ejmste/90554</a>	

**Q-methodology**

Chen Fang, Liwen Chen

<https://doi.org/10.29333/ejmste/90555>

2731–2733

**Correction on Formation of Academic Mobility of Future Foreign Language Teachers by Means of Media Education Technologies**

Sujuan Wang, Natalia V. Gorbunova, Alfiya R. Masalimova, Jana Bírová, Marina G. Sergeeva

<https://doi.org/10.29333/ejmste/90556>

2735



<http://www.ejmste.com>



<https://twitter.com/ejmste>



<https://www.facebook.com/ejmste>



<http://modestum.co.uk/>



[publications@modestum.co.uk](mailto:publications@modestum.co.uk)

# Mobile Virtual Reality as an Educational Platform: A Pilot Study on the Impact of Immersion and Positive Emotion Induction in the Learning Process

Elena Olmos-Raya <sup>1</sup>, Janaina Ferreira-Cavalcanti <sup>1</sup>, Manuel Contero <sup>1\*</sup>,  
M. Concepción Castellanos <sup>1</sup>, Irene Alice Chicchi Giglioli <sup>1</sup>, Mariano Alcañiz <sup>1</sup>

<sup>1</sup> I3B. Universitat Politècnica de València, Valencia, SPAIN

Received 20 November 2016 • Revised 13 December 2017 • Accepted 13 December 2017

## ABSTRACT

The purpose of this study is to evaluate the influence of emotional induction and level of immersion on knowledge acquisition and motivation. Two conditions were used for immersion modulation: a high immersive condition, which consisted of the viewing of educational content through a head-mounted-display; and a low immersive condition, which was achieved through direct viewing on a tablet. The emotional conditions, created through video simulation, consisted of a positive versus neutral mood induction procedure. The participants were 56 high school students enrolled on a social science course. The results indicate a significant effect of the positive emotion/high immersive condition in knowledge acquisition while positive emotion induction had a positive effect on the interest subscale of the motivation assessment tool used for both immersive conditions.

**Keywords:** immersion, emotion induction, motivation, knowledge acquisition, head-mounted display

## INTRODUCTION

The popularisation and accessibility of mobile Virtual Reality (mVR) technology in the coming years is likely to have a significant impact on educational contexts and the overall development of students as lifelong learners. Proposed by Motiwalla (2007) as a new technological approach for teaching, there are extensive opportunities for both traditional and distance education in the design of fully immersive experiences with high-quality visualisation and in combining them with the advanced interactive capabilities and connectivity offered by modern smartphones. As Jerald (2015) notes, Virtual Reality (VR) "has turned a corner, transitioning from a specialized laboratory instrument available only to the technically elite, to a mainstream mode of content consumption available to any consumer" (Jerald, 2015).

## LITERATURE REVIEW

Although research in the area of virtual reality technology has been ongoing for many years, its actual use and implementation in experiments in educational contexts are extremely limited, partly due to the high cost of this technology prior to the arrival of smartphone-based solutions (Google Cardboard was introduced in June 2014 and the first version of the Samsung Gear VR became available in December 2014). This is one of the reasons why Merchant et al. (2014) focused their meta-analysis on "desktop VR" (3D visualisations on a computer screen). They justified this in the light of the many practical concerns and limitations that restricted the widespread use of true Virtual Reality technology in educational settings. One of the many reasons why this technology was beyond the reach of schools was that it was not financially feasible. In addition, users were found to experience significant physical and psychological discomfort when using previous generations of VR hardware.



#### **Contribution of this paper to the literature**

- This is the first article to evaluate the influence of emotional induction and level of immersion on knowledge acquisition and motivation using mobile virtual reality hardware.
- The results indicate a significant effect of the positive emotion/high immersive condition on knowledge acquisition while positive emotion induction had a positive effect on participants' interest in both immersive conditions.
- Positive emotion is a stronger modulator than immersive condition for both knowledge acquisition and motivation, although the high immersive condition increases this positive effect.

True Educational Virtual Environments (EVEs) provide an immersive experience (Slater, 2009), contextualize content and support problem-solving inside the virtual environment (Tzuriel, 2000). We understand, in this context, "immersion" as being aligned with Slater's (1999) view that considers it as an objective measurable aspect of a Virtual Reality system (for example, the field of view could serve to compare to VR systems in terms of immersion). It represents the extent to which the system produces a surrounding environment, disconnecting us from 'real world' and providing a sharp panoramic vision of the virtual environment.

Other elements that can improve the effectiveness of EVEs have been inspired by video games in which events are experienced by the viewer (Bavelier et al., 2012). The visual complexity of videogames and the quantity of stimuli are factors that must also be considered (Bavelier et al., 2012). In addition, interaction with the individual's whole body and multisensorial inputs can also increase learning effectiveness (Fowler, 2014). Dalgarno and Lee (2010) also see the interaction capabilities and the high level of realism (both in the environment and in user actions) as strengths. Immersion in a digital environment can improve learning in three ways: it can provide multiple perspectives, it can contextualise the environment and it can help the transferability of learned material (Dede, 2009).

Most previous applications of EVEs have centred on mathematics and sciences (Mikropoulos & Natsis, 2011). This can be explained because immersive technologies make it easier to understand abstract concepts. As examples, we have chemistry experiments with students from secondary schools (Bell & Fogler, 1995), specific educational content for mathematical concepts with avatars personifying teachers and students (Taxén & Naeve, 2001), and in physics a study about mass gravity in the solar system (Civelek, et al., 2014). The results showed higher comprehensibility, achievement and retention over time.

There are a limited number of works applying this technology to the social sciences. It has been used to expose students to places and situations they couldn't possibly experience in real life, for example, the solar system (Bakas & Mikropoulos, 2003); and taking care of, being responsible for, the life cycle of a plant (Roussos et al., 1999). Ecology is another area which is open to the use of virtual environments. Wrzesien and Alcañiz (2010) compared an immersive environment with a non-immersive using a sample of primary students. The results were not significant, although the users described the immersive environment as being more enjoyable than the non-immersive one. Rupp et al. (2016), with the aim of evaluating the influence of immersion technology on expectation and degree of information recall of university students, developed a study comparing the results of a NASA film viewed variously on a Smartphone, a Google Cardboard and the Oculus Rift DK2. In this specific case, the use of the higher immersion hardware, when used by a higher expectation subject, resulted in the remembering of fewer details about the video. However, the research did highlight that the video was, in fact, inappropriate for the study as it included too many distractors.

Moreno's (2006) framework for the Cognitive-Affective Theory of Learning with Media postulates that the multimedia learning process is mediated by the learner's mood. Hascher (2010) provided a good overview of the state of the art at that point about the interaction of learning and emotion, proposing a general framework for theory and research in the field and showing the complexity of the topic. She makes emphasis that, despite the evidence of the positive effects of positive mood and emotions in the learning process, additional research is needed to advance the understanding of the complex relationship between emotion and learning.

Many works have contributed to the study of the relationship between learning and emotion. For example, Brand et al. (2007) provide findings showing that both positive and negative moods may hinder or promote information processing. In a first experiment, participants in a negative mood solved the transfer tasks poorly. In a second experiment, mood affected performance if it was induced before the learning phase; participants in a negative mood needed more attempts to reach the level required in the experiment. In other work, Park et al. (2015) demonstrated that learners with positive emotional states show better learning outcomes. Liew and Su-Mae (2016) developed an experimental work around learning a basic programming algorithm whose results revealed that negative mood enhanced intrinsic motivation and germane load, while reducing learning transfer. Nadler et al. (2010) induced positive, neutral, and negative moods in subjects learning either a rule-described or a non-rule-described category set. Subjects in the positive-mood condition performed better than subjects in the neutral- or

negative-mood conditions in classifying stimuli from rule-described categories. Positive mood also affected the strategy of subjects who classified stimuli from non-rule-described categories.

These previous works show that an important factor to consider in the development of virtual learning experiences is the “emotional feeling” that can be generated through interaction with the virtual environment. Learning tasks should develop positive emotions. It is important to note that information transmitted by the senses is easily retained in the limbic system, which is connected to the frontal cortex, both of which are involved in emotion.

Positive emotion stimulates curiosity, heightens attention and arouses interest in the topic being learned. The absence of emotion has consequences for learning and knowledge retention in academic life (Mora, 2013).

In order to contribute to a deeper understanding of the effects of immersion levels and emotional induction on the learning process when students are experiencing a learning activity inside an Educational Virtual Environment, the present study will analyse two experimental conditions: level of immersion (low/high) and emotional induction (neutral/positive) to evaluate their influence on short-term (knowledge acquisition) and medium-term knowledge retention (in our case, a week after conducting the experiment). The high immersion (HI) condition was obtained by creating sensory isolation from the surroundings via a head-mounted display (HMD), while the low immersion (LI) condition was achieved using a tablet. There were no substantial differences in the educational content presented in both conditions, either in terms of navigation or in the interaction interfaces. Therefore, we manipulated only one of the conditions that has traditionally proved to be necessary for increasing immersion to “remove the participant from the external world through self-contained plots and narratives” (Slater & Wilbur, 1997). Secondly, as previously described, we examined the effect of positive emotional induction and motivation on learning.

## MATERIALS AND METHODS

### Subjects

The experimental sample included 56 students, 23 girls and 33 boys, between the ages of 14-16 years, recruited from two private schools in Valencia (Spain), both of which use the same pedagogical approach. All the participants were in the same year at secondary school and had a history of academic failure. They were all from the same socioeconomic level. They had a maximum of 55 minutes to complete the entire activity (including questionnaires, emotional induction procedures and interaction with the educational content). The experiment was conducted during school times, mainly during the mornings.

Participants’ parents were provided with written information about the study and were required to give written consent for their children to take part. Only the parents completed the written consents. However, the teachers and the parents explained the activity to the participants.

### Psychological Assessment and Emotional Induction

The following questionnaires were presented to each participant:

- Knowledge Questionnaire (KQ): An ad hoc ten-item questionnaire was created by teachers to measure participant learning. Some sample questions are:
  - In the 14th century there was an important decrease of the population due to:
    - a) Wars
    - b) Lack of famine
    - c) The plague
  - Agriculture first appeared in:
    - a) Europe
    - b) Asia
    - c) Asia and America
  - The Industrial Revolution meant an increase in the population because of...
    - a) Technological advances and health improvements
    - b) Migration
    - c) Increase in the birth rate

- Self-Assessment Manikin (SAM): This is a well-validated, non-verbal questionnaire assessing the three affective dimensions: valence (positive or negative feeling caused by a situation: 1 = unhappy to 5 = happy), arousal (psychological posture of a person when faced with a condition: 1 = excited to 5 = sleepy) and dominance (measure of personal control: 1 = controlled to 5 = submissive). (Bradley & Lang, 1994).
- Intrinsic Motivation Inventory (IMI): This is a well-validated questionnaire, assessing the intrinsic motivation related to a specific activity. The questionnaire used a Likert scale (1 = disagree; 5 = agree) consisting of three subscales: competence (5 items), interest (5 items) and effort (4 items) (Ryan & Deci, 2000). The post-test and pre-test questionnaires has similar items. These items assess Competence using statements such as “I think I was good in making/playing this game” or “I am satisfied with my performance while making/playing the game”. Interest was assessed with statements such as “I think school is quite enjoyable” or “I think school is fun” and Effort with items such as “I put much effort into school” or “It was important to me to do well in making/playing this game”.

For emotional induction, we selected two movie clips, short film scenes with happy (3.56 minutes) and neutral (2.19 minutes) content. The happy scene was a snippet from “Singing in the Rain”. Specifically, a man is singing and dancing in the street. For the neutral content we used a snippet with a man driving a van along a road. Both snippets have been validated by Baños et al. (2004).

### **Experimental Design**

A 2x2 factorial design was applied. Two factors were considered: emotional induction (with two levels, positive and neutral) and immersion (with two levels, low and high). Participants were randomly assigned to one of the four experimental groups. Each of the four groups had 14 subjects to cover the four possible combinations of the factors.

The presentation order of each exposure condition (high and low immersive), as well as the order of appearance of each emotional stimuli category (emotional induction), in the two different conditions, was counterbalanced for each group. The participants completed a Knowledge Questionnaire (KQ) one week before the experiment. They were also asked to complete the IMI and the Self-Assessment Manikin (SAM) test (working baseline).

The experimental session started with the SAM questionnaire to measure the baseline, follow by the emotional induction. Then a SAM questionnaire was administered again to measure the effect of this induction. Participants were told to freely examine the educational content and undertake activities related to both learning environments (head-mounted display and tablet).

To measure the variation of each exposure condition, at the end of the experiment subjects completed the Intrinsic Motivation Inventory, the Self-Assessment Manikin and the Knowledge Questionnaires (short-term knowledge retention). Finally, after one week, participants again completed the Knowledge Questionnaire to measure their medium-term knowledge retention.

### **Educational Content**

Two educational apps were developed on the Android platform with almost exactly the same learning experience. The only difference was that one app was installed on an Android-powered tablet and the other was installed on a Samsung Gear VR headset powered by a smartphone. The activity was composed of 2D multimedia content in which students were guided through the app by a narrator.

At the beginning of the experiment, the narrator explained the task to the participants and they were shown a world map. Then the participants were asked to observe, focus their attention on, and prepare themselves to go on a trip in which a series of geographically-related topics were presented. The participants were exposed to the content for 8 minutes.

The topics explained in the application were:

1. The birth of agriculture. The audio narration explained where agriculture first appeared while this information was represented graphically to show its geographical location.
2. Plagues in Europe. The second module dealt with the theme of epidemics. The European continent was highlighted. Death was represented by a death doll moving over the continent with the colour changing to black as the narrator speaks about the medieval plagues in Europe.
3. The Industrial Revolution. The map focused on Great Britain (**Figure 1**) and the illustrations that appeared show how industry expanded. The module explained how this phenomenon happened and how it spread to the rest of Europe.

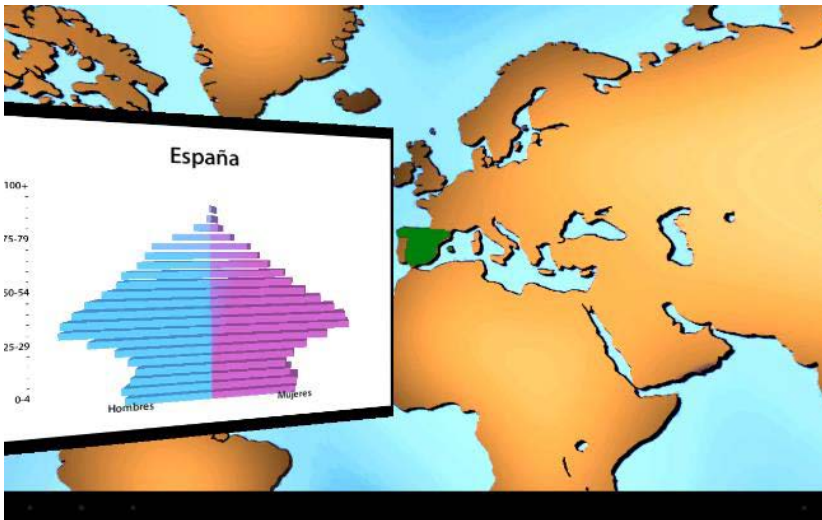


**Figure 1.** Screenshot from the Industrial Revolution module



**Figure 2.** Screenshot of the most highly populated areas in America

4. Population distribution and the evolution of the phenomenon. The principal aim of this module was to highlight the facts (physical, economic and demographical) which influence population distribution. The narrator pointed out the most highly populated areas in the world; and the images of these countries was highlighted with a different colour and with relevant photographs of individuals (**Figure 2**).
5. Why we cannot live in some places? The principal aim of this topic was to describe the reasons that lead people to live in specific geographical areas.
6. Population movements. This module taught students the formulae of births, deaths and the rate of natural increase. It studied population movements, their causes and consequences. Furthermore, in this section, the population pyramid concept was explained (**Figure 3**).



**Figure 3.** Screenshot of the Spanish population pyramid



**Figure 4.** High immersion condition

After each learning module, participants had to answer some questions in two ways:

- High immersion condition: students used a red point in the middle of the virtual environment. This could be moved by turning the head towards the desired location to give the correct answer. Or the area of a map could be highlighted by putting a finger on the touchpad on the right side of the headset. (**Figure 4**)
- Low immersion condition: students had to choose the correct answer by touching the tablet screen. (**Figure 5**)





**Figure 5.** Low immersion condition

### Hardware

The hardware used in the experiment was a Samsung Gear VR headset equipped with a Samsung Galaxy Note 4 smartphone featuring a 5.7 inch Quad-HD display (2560 x 1440 pixels) with 515 dpi resolution and an Android tablet featuring a 10-inch touch screen.

### RESULTS

The analyses were performed using SPSS version 22.0 (Statistical Package for the Social Sciences for Windows, Chicago, IL) for PC. Independent tests were conducted to verify the baseline homogeneity of the sample in terms of age. Since the sample was characterised by statistically significant baseline differences, psychological differences were calculated in the Intrinsic Motivation Inventory (IMI) and SAM data measured after exposure compared to the corresponding baseline. Next, mixed ANOVAs (and ANCOVAs) were conducted to test whether the psychological responses changed according to the exposure condition (High Immersive or Low Immersive), or the type of emotional induction (Positive or Neutral). The level of significance was set at  $\alpha = .05$ .

#### Intrinsic Motivation Inventory (IMI)

Cronbach's alphas for pre- and post-test questionnaires were calculated to evaluate the internal consistency of the competence, effort and interest scales of the intrinsic motivation inventory. As can be seen in **Table 1**, subscale homogeneity was assessed using the corrected item-total correlation. The internal consistency for the pre- and post-competence scales was found to be good (.84 and .78, respectively). For the pre-test effort questionnaire, reliability was good (.85), while for the post-test effort questionnaire it was poor (.59). For the interest questionnaire, the reliability of neither pre- nor post-test questionnaires was acceptable (.41 for the pre-test and .43 for the post-test). In both interest questionnaires, the internal consistency was found to be good (.81 for both pre- and post-test questionnaires) when the "I think school is boring" item in the pre-test questionnaire and "I think doing this activity is boring" item in the post-test questionnaire were eliminated. Therefore, these items were not included in the follow up analysis.

**Table 1.** Format of the intrinsic motivation scales (IMI) and the corrected item total correlations for pre- and post-tests.

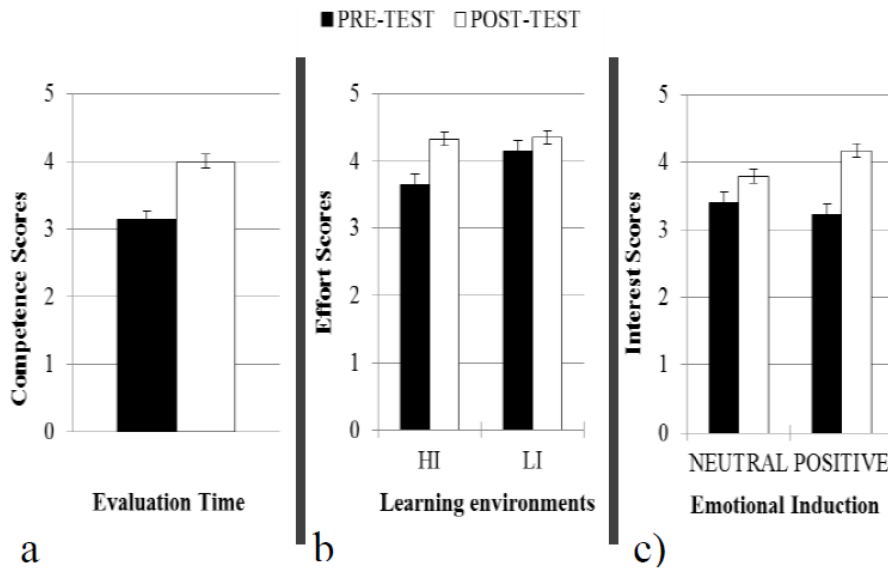
IMI Scales	Pre-test	Corrected item-total correlation	Post-test	Corrected item-total correlation C
Competence	I think I am good at school	.66	I think I was good in doing this activity	.62
	I think I do pretty well at school, compared to others	.68	I think I did pretty well in doing this activity, compared to others	.30
	I am pretty skilled at school	.57	I was pretty skilled at doing this activity	.74
	I think I am pretty good at school	.68	I think I was pretty good in doing this activity	.65
	I am satisfied with my performance at school	.62	I am satisfied with my performance while doing the activity	.56
	Reliability (Cronbach's $\alpha$ )	.84	Reliability (Cronbach's $\alpha$ )	.80
Effort	I try very hard to do well at school	.66	I tried very hard to do well in doing this activity	.38
	I do my best at school	.80	I did my best while I was doing the activity	.39
	It is important to me to do well at school	.59	It was important to me to do well in doing this activity	.42
	I put much effort in school	.79	I put much effort in doing this activity	.37
	Reliability (Cronbach's $\alpha$ )	.86	Reliability (Cronbach's $\alpha$ )	.62
Interest	At school I often think about how much I enjoy it	.46	While I was doing the activity, I often thought about how much I enjoyed it	.49
	I think school is boring	-.55	I think doing this activity was boring	-.69
	I think school is quite enjoyable	.61	I think doing this activity was quite enjoyable	.59
	I think school is very interesting	.47	I think doing this activity was interesting	.53
	I think school is fun	.62	I think doing this activity was fun	.56
Reliability (Cronbach's $\alpha$ )	.45 / .81 <sup>a</sup>	Reliability (Cronbach's $\alpha$ )	.43 / .81 <sup>a</sup>	

We carried out Pearson correlations to investigate the measurement stability of the scales. The pre-test questionnaires aimed at measuring general intrinsic motivation at school while the post-test questionnaires aimed at measuring lesson-specific intrinsic motivation; thus the latter measure diverged from the former. None of the competence, effort or interest post-test scales had significant correlations with their respective pre-test scales ( $r = .20, r = -.83, r = .14,$  and  $p > .05,$  respectively). Due to this divergence, we examined the differences between the pre-test and post-test scores on the intrinsic motivation scales for the four conditions using a mixed ANOVA with the evaluation time (pre- and post-test) as a repeated measure, and the emotional induction and learning environment as factors.

For the competence scale, we found only one main effect of evaluation time,  $F(1,52) = 45.02, p < .001, \eta^2 = .46.$  In the pre-test questionnaire about school, students rated themselves as being less competent in the specific lesson (Mean  $\pm$  Standard Deviation:  $3.13 \pm 0.85$ ) than in the post-test questionnaire ( $3.99 \pm 0.58$ ). For the other main and interaction effects the score was  $p > .05.$

Students rated their level of effort in the specific lesson ( $4.35 \pm 0.81$ ) as being higher than in their general effort made at school ( $3.91 \pm 0.51$ ),  $F(1,52) = 13.23, p = .001, \eta^2 = .20.$  The interaction of evaluation time and level of immersion was marginally significant,  $F(1,52) = 3.88, p = .07, \eta^2 = .07.$  Pairwise-comparisons yielded significant differences in the rated effort between pre- and post-test scores ( $3.85 \pm 0.85$  and  $4.37 \pm 0.44$ ), but only in the high immersion group,  $p < .001.$  For the low immersion group, these score were, respectively,  $3.96 \pm 0.78$  vs.  $4.30 \pm 0.57,$  and  $p > .05.$  All the other main and interaction effects were non-significant,  $p > .05.$

Students were more interested in the map activity ( $3.98 \pm 0.70$ ) than in school ( $3.31 \pm 0.82$ ),  $F(1,52) = 20.08, p < .001, \eta^2 = .28$  (see Figure 6). We also found that the interaction of evaluation time with emotional induction was marginally significant,  $F(1,52) = 3.37, p = .072, \eta^2 = .06.$  In the pre-test scores about school there was no difference between the positive and neutral groups ( $3.39 \pm 0.89$  vs.  $3.79 \pm 0.75,$  respectively),  $p > .05,$  but in the post-test score about the activity, interest was higher in the positive group than in the neutral group ( $4.17 \pm 0.59$  vs.  $3.23 \pm 0.75$ ),  $p = .041.$  None of the other main and interaction effects were significant ( $p > .05$ ).

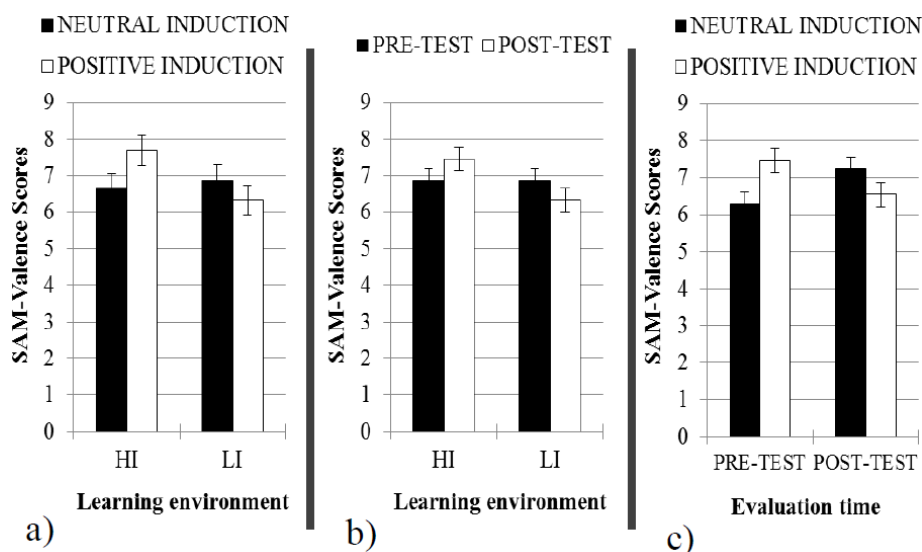


**Figure 6.** Mean scores on the intrinsic motivation scales: a) effect of evaluation time for the competence scale; b) Evaluation time x learning environment interaction for the effort scale; c) Evaluation time x emotional induction interaction for the interest scale. Bars represent standard errors of the mean.

### Self-Assessment Manikin (SAM) Test

To measure the students' emotional responses, we analysed the valence scale of the SAM test. Because the baseline test scores (before the emotional induction) were correlated with the pre-test scores (after the emotional induction and before the lesson,  $r = .44, p = .001$ ) and post-test scores (after the lesson,  $r = .38, p < .001$ ), this baseline was used as a covariate in a subsequent mixed ANCOVA carried out to investigate the effect of the emotional induction in conjunction with the different levels of immersion. We used the valence SAM scores of each evaluation as repeated measures and the type of emotional induction and level of immersion as factors. The baseline effect was the only main effect which was significant,  $F(1,51) = 13.73, p < .001$ , showing that the pre-induction scores predicted the subsequent scores. When this effect was removed, we found that interaction between the level of immersion x emotional induction was marginally significant,  $F(1,51) = 3.94, p = .053, \eta^2 = .07$ . Students' scores were higher in the positive group ( $7.68 \pm 1.70$ ) than in the neutral ( $6.86 \pm 1.90$ ), but only in the high immersion group (pairwise-comparisons,  $p = .021$ ; for the low immersion group, the scores were, respectively,  $6.04 \pm 2.53$  vs.  $6.96 \pm 1.23$ , and  $p > .05$ ).

Moreover, the evaluation x level of immersion, and the evaluation x emotional induction effects were found to be significant,  $F(1,51) = 6.98, p = .011, \eta^2 = .12$ , and  $F(1,51) = 19.01, p < .001, \eta^2 = .27$ , respectively. Valence scores were higher in the high immersion group ( $7.54 \pm 1.73$ ) than in the low immersion group ( $6.25 \pm 2.07$ ), but only after the lesson (post-test scores, pairwise-comparisons,  $p = .017$ ) and there was no difference between them ( $7.00 \pm 1.92$  vs.  $6.75 \pm 1.99$ ) after the emotional induction (pre-test scores, pairwise-comparisons,  $p > .05$ ). Valence scores were also higher for the positive induction group ( $7.29 \pm 2.17$ ) than for the neutral induction group ( $7.14 \pm 1.41$ ) after the emotional induction (pairwise-comparisons,  $p = .013$ ), although this difference disappeared after the lesson ( $6.43 \pm 2.36$  vs.  $6.46 \pm 1.62, p > .05$ ) (Figure 7).



**Figure 7.** Mean scores of the different interactions in valence scores: a) Learning environment x emotional induction interaction; b) evaluation time x learning environment interaction; c) evaluation time x emotional induction interaction. Bars represent standard errors of the mean.

### Knowledge Acquisition

In order to determine whether changing the level of immersion and emotional induction yielded differences in terms of knowledge acquisition, we analysed the gains and losses of knowledge between the Knowledge Questionnaire scores from the pre-test, the immediate post-test and the delayed post-test. The pre-test Knowledge Questionnaire scores were the baseline for the immediate post-test ones, and the immediate post-test Knowledge Questionnaire scores were the baseline for the delayed post-test scores. To achieve this, we carried out a mixed ANOVA including level of immersion and emotional induction as factors, and the knowledge gain in each post-test time as repeated measures with two levels. The first level was the immediate post-test Knowledge Questionnaire scores minus the pre-test scores (immediate knowledge gain), and the second was the delayed post-test Knowledge Questionnaire scores minus the immediate post-test ones (delayed knowledge gain).

The main effect of knowledge gain,  $F(1,52) = 45.53, p < .001, \eta^2 = .45$ , and of emotional induction were significant,  $F(1,52) = 5.37, p = .024, \eta^2 = .06$ , while level of immersion was marginally significant,  $F(1,52) = 3.09, p = .085, \eta^2 = .06$ . The knowledge gain was higher among students who received positive emotional induction ( $0.73 \pm 1.83$ ) compared to students in the neutral induction group ( $0.14 \pm 2.18$ ), and was marginally higher in the high immersion group ( $0.66 \pm 2.42$ ) compared to the low immersion group ( $0.21 \pm 1.51$ ). The knowledge gain was also higher just after the lesson ( $.50 \pm 1.81$ ) compared to the delayed post-test, in which there was actually a knowledge loss ( $-0.63 \pm 1.64$ ). This gain was mediated by the level of immersion,  $F(1,52) = 20.69, p < .001, \eta^2 = .29$ . The difference between the immediate gain ( $2.46 \pm 1.68$ ) and the delayed gain ( $1.14 \pm 1.53$ ) was only significant in the high immersion group (pairwise-comparison,  $p < .001$ ; for the low immersion group,  $0.54 \pm 1.37$  vs.  $-0.11 \pm 1.59, p > .05$ , respectively). The other interactions were not significant with  $p > .05$ . (Figure 8).

### Effect of Emotional Induction

We found a higher effect of positive emotion compared to neutral in the different assessments:

- 1) The assessment of participants' interest after the lesson, the positive group being more interested than the neutral one.
- 2) Students' valence scores were higher for the positive induction group than for the neutral induction group after the emotional induction but not after the lesson. In addition, valence scores were higher in the positive group than in the neutral but only for the high immersion group.
- 3) Finally, the knowledge gain was higher among students who received positive emotional induction compared to students in the neutral induction group.

## DISCUSSION

Regarding the first objective of this study (influence in short-term knowledge retention by comparing high immersion versus low immersion states), we can conclude that the immersive condition influences knowledge retention when delivering educational content. In the short term, participants have better retention when there is positive emotional induction and high immersion. The statistical analysis showed increased medium-term learning in the high immersion condition.

These results are in line with the previous work of Kort et al. (2001), which highlighted the existence of interaction between emotion and learning. Their research focused on student emotions during the learning process. Feelings of amazement, satisfaction, curiosity, hope, and inquiry were identified as good emotions which were associated with a higher level of learning. Our results also agree with Reschly et al. (2012), who studied the impact of positive emotion on student engagement. We can conclude that positive emotion increases engagement, and this can be seen as a multidimensional construct related to academic improvement, as proposed by Lyubomirsky et al. (2005).

Regarding the second main aim of this experimental work (analysing whether manipulating an emotion affects participant motivation), a psychological assessment analysis revealed a significant difference in the interest subscale between the pre-tests and post-tests in the high immersion condition.

This result is also aligned with previous works. For example, Turner, Meyer, and Schweinle (2003) analysed the learning process based on three elements: cognition, emotion and learning. They observed that emotion was an essential component for student motivation. This was also noted by Tüzün et al. (2009), when they compared student motivation in a primary school using a game-based learning approach as against a traditional schoolroom based approach. They observed that students demonstrated statistically significant higher intrinsic motivation and lower extrinsic motivation when learning in the game-based environment. Wrzesien and Alcañiz (2010) observed a similar effect in a study of the learning of natural sciences and ecology in a primary school. One group of students carried out a learning activity in an immersive environment while the other group used a 2D representation. Results showed that the students using the immersive environment were more satisfied with their learning experience. The authors concluded that immersive environments have the ability to improve students' intrinsic motivation.

Finally, considering the third objective of this work (determining whether positive emotion helps students retain educational content), we observed that valence scale values were higher when there was positive emotional induction and high immersion. This statistically significant difference was found after the task but not after the emotional induction, meaning that high immersion can be used as a tool to enhance the influence of emotions. This is an interesting fact, especially when considered in conjunction with the ideas of Dirkx (2001) about the importance of emotions as elements that can either impede or motivate learning.

There are some limitations to the study that should be highlighted. Although there were 56 participants, each experimental condition was covered by only 14 subjects (2x2 design). More significant interactions between the experimental conditions would probably have been detected in a larger sample. It is also worth mentioning that the emotional induction procedure applied should be analysed in greater detail. There are factors related to sociocultural background and the age of the subjects that could have an impact on the effectiveness of the induction procedure. This would require more specific fine-tuning of the process to select the most relevant film to obtain the desired emotional induction.

## REFERENCES

- Bakas, C., & Mikropoulos, T. (2003). Design of virtual environments for the comprehension of planetary phenomena based on students' ideas. *International Journal of Science Education*, 25(8), 949-967. <https://doi.org/10.1080/09500690305027>
- Baños, R. M., Botella, C., Alcañiz, M., Liaño, V., Guerrero, B., & Rey, B. (2004). Immersion and emotion: their impact on the sense of presence. *Cyberpsychology & Behavior: The Impact of the Internet, Multimedia and Virtual Reality on Behavior and Society*, 7(6), 734-741. <https://doi.org/10.1089/cpb.2004.7.734>
- Bavelier, D., Green, C. S., Pouget, A., & Schrater, P. (2012). Brain plasticity through the life span: learning to learn and action video games. *Annual Reviews of Neuroscience*, 35, 391-416. <https://doi.org/10.1146/annurev-neuro-060909-152832>
- Bell, J. T., & Fogler, H. S. (1995). The Investigation and application of virtual reality as an educational tool. Paper presented at the *American Society for Engineering Education 1995 Annual Conference*. Retrieved from <https://www.researchgate.net/publication/247920944>



- Bradley, M., & Lang, P. J. (1994). Measuring emotion: the self-assessment semantic differential manikin and the semantic differential. *Journal of Behavior Therapy and Experimental Psychiatry*, 25(1), 49-59. [https://doi.org/10.1016/0005-7916\(94\)90063-9](https://doi.org/10.1016/0005-7916(94)90063-9)
- Brand, S., Reimer, T., & Opwis, K. (2007). How do we learn in a negative mood? Effects of a negative mood on transfer and learning. *Learning and Instruction*, 17(1), 1-16. <https://doi.org/10.1016/j.learninstruc.2006.11.002>
- Civelek, T., Ucar, E., Ustunel, H. & Aydm, M. K. (2014). Effects of a Haptic Augmented Simulation on K-12 Students' Achievement and their Attitudes toward Physics. *Eurasia Journal of Mathematics, Science & Technology Education*, 10(6), 565-574. <https://doi.org/10.12973/eurasia.2014.1122a>
- Dalgarno, B., & Lee, M. J. W. (2010). What are the learning affordances of 3-D virtual environments? *British Journal of Educational Technology*, 41(1), 10-32. <https://doi.org/10.1111/j.1467-8535.2009.01038.x>
- Dede, C. (2009). Immersive interfaces for engagement and learning. *Science*, 323, 66-69. <https://doi.org/10.1126/science.1167311>
- Dirkx, J. M. (2001). The power of feelings: emotion, imagination, and the construction of meaning in adult learning. *New Directions for Adult and Continuing Education*, 2001(89), 63-72. <https://doi.org/10.1002/ace.9>
- Fowler, C. (2014). Virtual reality and learning: where is the pedagogy? *British Journal of Educational Technology*, 46(2), 412-422. <https://doi.org/10.1111/bjet.12135>
- Hascher, T. (2010). Learning and Emotion: perspectives for theory and research. *European Educational Research Journal*, 9(1), 13-28. <https://doi.org/10.2304/eeerj.2010.9.1.13>
- Jerald, J. (2015). *The VR book: human-centered design for virtual reality*. New York, NY: Association for Computing Machinery and Morgan & Claypool. <https://doi.org/10.1145/2792790>
- Kort, B., Reilly, R., & Picard, R. W. (2001). An affective model of interplay between emotions and learning: Reengineering educational pedagogy-building a learning companion. Paper presented at the *IEEE International Conference on Advanced Learning Technologies, ICALT 2001*. <https://doi.org/10.1109/ICALT.2001.943850>
- Liew, T. W., & Su-Mae, T. (2016). The effects of positive and negative mood on cognition and motivation in multimedia learning environment. *Journal of Educational Technology & Society*, 19(2), 104.
- Lyubomirsky, S., King, L., & Diener, E. (2005). The benefits of frequent positive affect: Does happiness lead to success? *Psychological Bulletin*, 131(6), 803-855. <https://doi.org/10.1037/0033-2909.131.6.803>
- Merchant, Z., Goetz, E. T., Cifuentes, L., Keeney-Kennicutt, W., & Davis, T. J. (2014). Effectiveness of virtual reality-based instruction on students' learning outcomes in K-12 and higher education: A meta-analysis. *Computers and Education*, 70, 29-40. <https://doi.org/10.1016/j.compedu.2013.07.033>
- Mikropoulos, T. a., & Natsis, A. (2011). Educational virtual environments: A ten-year review of empirical research (1999-2009). *Computers and Education*, 56, 769-780. <https://doi.org/10.1016/j.compedu.2010.10.020>
- Mora, F. (2013). *Neuroeducación*. Madrid, España: Alianza Editorial. <https://doi.org/10.1017/CBO9781107415324.004>
- Moreno, R. (2006). Does the modality principle hold for different media? A Test of the method-affects-learning hypothesis. *Journal of Computer Assisted Learning*, 22(3), 149-158. <https://doi.org/10.1111/j.1365-2729.2006.00170.x>
- Motiwalla, L. F. (2007). Mobile learning: A framework and evaluation. *Computers and Education*, 49, 581-596. <https://doi.org/10.1016/j.compedu.2005.10.011>
- Nadler, R. T., Rabi, R., & Minda, J. P. (2010). Better mood and better performance: Learning rule-described categories is enhanced by positive mood. *Psychological Science*, 21(12), 1770-1776. <https://doi.org/10.1177/0956797610387441>
- Park, B., Knörzer, L., Plass, J. L., & Brünken, R. (2015). Emotional design and positive emotions in multimedia learning: An eyetracking study on the use of anthropomorphisms. *Computers & Education*, 86, 30-42. <https://doi.org/10.1016/j.compedu.2015.02.016>
- Reschly, A. L., Huebner, E. S., Appleton, J. J., & Antaramian, S. (2012). Engagemt as flourishing: the contribution of positive emotions and coping to adolescents. Engagement at school and with learning. *Journal of Adolescence*, 74(4), 274-283. <https://doi.org/10.1002/pits.20306>
- Roussos, M., Johnson, A., Moher, T., Leigh, J., Vasilakis, C., & Barnes, C. (1999). Learning and building together in an immersive virtual world. *Presence: Teleoperators and Virtual Environments*, 8(3), 247-263. <https://doi.org/10.1162/105474699566215>

- Rupp, M., Kozachuk, J., Michaelis, J. R., Odette, K. L., Smither, J. A., & McConnell, D. S. (2016). The effects of immersiveness and future VR expectations on subjective experiences during an educational 360 o video. *Proceedings of the Human Factors and Ergonomics Society*, 2108-2112. <https://doi.org/10.1177/1541931213601477>
- Ryan, R. M., & Deci, E. L. (2000) Self-determination theory and the facilitation of intrinsic motivation, social development, and well-being. *American Psychologist*, 55(1), 68-78. <https://doi.org/10.1037/0003-066X.55.1.68>
- Slater, M. (1999). Measuring presence: A response to the Witmer and Singer presence questionnaire. *Presence: Teleoperators and Virtual Environments*, 8(5), 560-565. <https://doi.org/10.1162/105474699566477>
- Slater, M., & Wilbur, S. (1997). A Framework for Immersive Virtual Environments (FIVE): Speculations on the Role of Presence in Virtual Environments. *Presence: Teleoperators and Virtual Environments*, 6(6), 603-616. <https://doi.org/10.1162/pres.1997.6.6.603>
- Taxén, G., & Naeve, A. (2001). *CyberMath: A shared virtual environment for mathematics exploration* (Report No. CID-129). Retrieved from <http://cid.nada.kth.se/pdf/CID-129.pdf>
- Turner, J. C., Meyer, D. K., & Schweinle, A. (2003). The importance of emotion in theories of motivation: Empirical, Methodological, and Theoretical Considerations from a Goal Theory Perspective. *International Journal of Educational Research*, 39, 375 -393. <https://doi.org/10.1016/j.ijer.2004.06.005>
- Tüzün, H., Yılmaz-Soylu, M., Karakus, T., Inal, Y., & Kizilkaya, G. (2009). The effects of computer games on primary school students' achievement and motivation in geography learning. *Computers and Education*, 52(1), 68-77. <https://doi.org/10.1016/j.compedu.2008.06.008>
- Tzuriel, D. (2000). Dynamic assessment of young children: Educational and intervention perspectives. *Educational Psychology*, 12(4), 385-435. <https://doi.org/10.1023/A:1009032414088>
- Wrzesien, M., & Alcañiz Raya, M. (2010). Learning in serious virtual worlds: Evaluation of learning effectiveness and appeal to students in the E-Junior project. *Computers and Education*, 55(1), 178-187. <https://doi.org/10.1016/j.compedu.2010.01.003>

<http://www.ejmste.com>



For print copies of this issue or articles please send an e-mail to:

[print@modestum.co.uk](mailto:print@modestum.co.uk)

## Analysis of the Learning Effectiveness of Atayal Culture CPS Spatial Concept Course on Indigenous Students

Jenyi Chao <sup>1\*</sup>, Chuan-Hsi Liu <sup>2</sup>, Yi-Hsin Yeh <sup>1</sup>

<sup>1</sup> National Taipei University of Education, Taipei, TAIWAN

<sup>2</sup> National Taiwan Normal University, Taipei, TAIWAN

Received 9 May 2017 • Revised 4 October 2017 • Accepted 7 November 2017

### ABSTRACT

This study was conducted by integrating Atayal culture into CPS education strategy to develop spatial concept courses, teaching materials, and assessment tests that served to analyze the effectiveness of spatial concept learning on indigenous students after two years of course. The participants of this study were 16 5th grade students from an Atayal elementary school located in Nan'ao, Yilan County. The period of study spanned from 2015 to 2016, and was conducted by gathering data through teaching demonstrations and tests. The tests developed for this study were used as the research tool, and had been examined and pretested by 3 content specialists. The finalized tests included a total of 19 segments (59 problems) on 6 spatial concepts: "rotation", "reflection", "folding", "perspective", "stacking", and "cubic enumeration". The tests were conducted before and after the study and verified against sample t to examine if the indigenous students' spatial concepts exhibited significant changes. Study results showed that with regard to the 6 different spatial concept tests, indigenous students performed significantly better in the after-tests than in the pre-tests. The integration of Atayal culture into CPS spatial concept courses was therefore determined to have significant positive impact on the spatial concepts of indigenous students.

**Keywords:** indigenous elementary children, spatial concept, Atayal culture, collaborative problem solving

### INTRODUCTION

This study comprises the partial research outcomes of the "Development and Implementation of a Teaching Platform for Indigenous Student CPS Spatial Conceptualization Learning Courses and Assessments--Main Project" funded by the Ministry of Science and Technology, Taiwan. A spatial conceptualization CPS teaching course and corresponding assessment test were designed in accordance with the context of Atayal culture to improve indigenous student' learning motivation toward spatial concepts so as to improve their learning outcomes and problem-solving skills. Student also acquired a better understanding of their culture.

Among Taiwanese indigenous peoples, the population of the Atayal tribe is about eighty thousand people, making them the third largest indigenous group after the Amis and the Payuan peoples (Department of Statistics, Ministry of the Interior, 2015). In particular, Nan'ao Township and its northwest neighbor Datong Township are the only two highland indigenous townships within Yilan County. Residents comprise mostly of Taiwanese indigenous people, the Atayal tribe, who have established a very unique culture. Since most of the indigenous students from Yilan County, Taiwan, who participated in this study were Atayal, the course incorporated the cultural features of the Atayal tribe so that the students are better able to connect emotionally with their tribal culture.

The objectives of this study are as follows: To learn whether or not there is significant improvement on the learning outcome of Atayal indigenous students in terms of six spatial concepts, namely, "Rotation," "Reflection,"

#### **Contribution of this paper to the literature**

- There is significant improvement on the learning outcome of Atayal indigenous students in terms of six spatial concepts, namely, "Rotation," "Reflection," "Folding," "Perspective," "Stacking," and "Cubic enumeration," after CPS coursework.
- This study is to improve the motivation for learning and learning outcomes of indigenous students. By integrating course design with indigenous culture and formulating appropriate CPS teaching strategies, both instructors and indigenous students can be empowered.
- The lifestyle-oriented assessment questions were incorporated indigenous cultural elements and utilized interactive digital materials designed by this study for CPS teaching demonstrations. This enabled us to understand the spatial intelligence of indigenous students and to improve their scientific, mathematic, and collaborative problem-solving skills.

"Folding," "Perspective," "Stacking," and "Cubic enumeration," after two years of coursework. The research question is as follows: Is there significant progress between pre-test and post-test scores in the six spatial concepts?

## LITERATURE

### **The Learning Difficulties of Indigenous Students**

Alleviating the difficulties faced by indigenous students has always been a focus of indigenous education. John Ogbu (as cited in Ho, 2015), an anthropologist of education, once mentioned that one of the reasons why minority students perform poorly was that the education they received was not compatible with their cultural backgrounds. This is a keen observation of the difficulties faced by indigenous students today in a Han-dominated culture. Moreover, indigenous populations in remote regions have relatively fewer economic, cultural, and educational resources. Lack of cultural stimulus and estrangement from mainstream culture has caused indigenous students to be less motivated in learning and thus exhibit poorer learning outcomes. In the long run, being disadvantaged both academically and in terms of career development restricts the social mobility of indigenous populations and prevents them from pursuing professional careers, creating a vicious cycle.

Upon the compilation of domestic studies on indigenous student learning patterns, it was found that cultural differences between the indigenous and Han populations have contributed to the differences in learning patterns and characteristics of the two groups. Taking the Atayal students of this study as an example, it was found that "peer-oriented learning" with an emphasis the values of cooperation and sharing was characteristic of their learning. They also enjoyed a stress-free learning atmosphere that had no competition pressure, and a dynamic, investigation-oriented learning environment with hands-on experiences. These characteristics made it difficult for Atayal students to become accustomed to the education system that was formulated based on Han culture. Atayal students disliked the lifeless instruction methods and learning materials comprised of symbols and abstractions (Chi & Liu, 2000).

Studies on the learning of indigenous students have pointed out that the gap between indigenous students and traditional teaching and the mainstream Han culture has not only affected their learning, but has also been the primary factor resulting in learning difficulties and poor learning outcomes (Chou et al., 2015). If culture is indeed the primary factor affecting the learning process of indigenous students, then, according to learning theories, teaching activities could be designed based on students' characteristics so as to increase their potential and resolve the issues encountered. Both domestic and foreign scholars have suggested that the learning characteristics of student should be taken into consideration in the formulation of methods, designs, and strategies for teaching indigenous students. Their cultural and living experiences should be incorporated, and instruction should be given according to how the students learn best so that their motivation for learning and learning outcomes can be improved.

### **Spatial Ability and Scientific Learning**

Indigenous education and culture are both issues of the research concern. Our research focus on the indigenous student science education all the time, and has been devoted to improving the motivation for learning and learning outcomes of indigenous students. By integrating course design with indigenous culture and formulating appropriate teaching strategies, both instructors and indigenous students can be empowered.

It has be found, however, that due to the influence of their living environment, indigenous students may not express their spatial concepts precisely enough, which, in turn, affects their performance in the natural sciences (Chao et al., 2014). There is also a significant gap between the spatial test results of indigenous students and of Han



students; in short, indigenous students in general have poorer spatial intelligence. It can be seen from the above observation that, in the process of helping indigenous students achieve better performances in scientific learning, their spatial concepts must also be improved (Chao et al., 2012, 2015).

In a recent domestic study, Lin (1994) pointed out that spatial intelligence is a basic capability for learning all sorts of knowledge. Wu (2001) also believes that those who have a higher spatial intelligence perform better in terms of learning ability, ability in scientific deduction, and creativity. Moreover, they are more proactive, aggressive and willing to challenge themselves. Wang and Chen (2016), on the other hand, suggested that to help a child overcome difficulties in the learning of mathematics (geometry, in particular), the instructor should begin from building the child's spatial ability.

Psychologists from earlier eras used factor analysis to discover the so-called "spatial ability" as one of the human mental abilities, which was not thought to affect the learning of academic subjects. It was not until the 1970s that many scholars started to study the relation between "spatial ability" and "scientific learning;" many subsequent studies pointed out that "spatial ability" clearly has an influence on a student's scientific learning (Lord, 1985a, 1985b; Weckbacher & Okamoto, 2014). Researchers each have their individual perspectives and stances, and have also formulated different definitions and interpretations of "spatial ability." For example, for McGee (1979), Linn and Peterson (1985), and Lohman (1988), a "spatial ability" refers to the ability to re-order, turn, and manipulate objects. Even though all these three studies proposed that "spatial visualization" is one of the spatial abilities, each proposed varying definitions for the concept of "spatial visualization."

McGee's "spatial visualization" has a relatively broader scope. "Spatial perception," according to Linn and Peterson, is close in meaning to "spatial orientation," whereas another two factors, "mental spin" and "spatial visualization" are closer in meaning to their definition of "spatial visualization." Therefore, in this study McGee's categorization of spatial capacity was adopted, including the six concepts of "Rotation," "Reflection," "Perspective," "Folding," "Stacking," and "Cubic enumeration." Digital teaching materials and assessment tests were all developed using these six general categories.

### **Collaborative Problem Solving (CPS) and PISA**

As mentioned above, indigenous education should take students' learning characteristics into account and their culture and background should be integrated. Teaching methods that cater to how students learn best is indispensable for improving their motivation for learning and learning outcomes. Other than preference for team work, hands-on experience, and learning with the senses, Fu (2004) also pointed out that within the traditional indigenous lifestyle, interpersonal relations include not only interactions between humans, but also between humans and plants, animals, and other substances. Therefore, indigenous people tend to learn via cooperation. The design of natural science instruction should adopt cooperative learning in place of individual competition, and be conducted primarily through outdoor rather than indoor learning activities.

Cooperative learning theories began to proliferate in the 1970s. These theories, based on democratic learning theory, theories of motivation, cognitive development theory, theories of social construction, and multiple Intelligence theory. Scholars have moreover developed many learning strategies for group collaborative work--at least eighty types have been identified abroad (Chang, 2010). Cooperative learning is mostly commonly utilized for group-based teaching, and is applicable to all sorts of subject and fields.

Problem-based learning (PBL) is another learning activity that enables students to solve problems structurally through group-based learning. In the process of problem-solving, not only do learners acquire and develop deductive creativity and cognitive ability, but can also exchange and build up their knowledge in the interactive process of group learning. Ultimately, information can be integrated into an effective action plan. Thereafter, Nelson (1999) proposed another teaching strategy, the collaborative problem solving (CPS) strategy, which combines the two methods of collaborative learning and problem-based learning to create an improved teaching strategy. This teaching strategy emphasizes a collaborative learning environment that is learner-oriented, integrable, and real. It encourages students to learn from doing and become active participants of the learning process. It stresses critical thinking and problem-solving abilities, helps cultivate social interaction and cooperation skills, and encourages the discovery and analysis of learning content from various perspectives.

DeWitt et al. (2017) referred that CPS can support online learning by enabling interactions for social and cognitive processes. The pretests and posttests of this study were conducted to determine whether the learning outcomes were achieved. The findings suggest that the module could be used to improve outcomes of learning and encourage interactions for cognitive processes and online presences. Although the subject and topic were not the same as ours, they still have similar views about that CPS strategies were effective in science education and enabled interactions for social and cognitive processes. It also mentioned that social interaction prompted cognitive processes such as concept-formation, resolving differences and critical thinking in the process of CPS, and it would

help students to obtain knowledge and skills (DeWitt et al., 2017; Huang, Yang, Chiang, & Tzeng, 2012; Chao et al., 2016a, 2016b; Karpov & Haywood, 1998; Kim & Song, 2006).

Chan and Clarke (2017) observed the students' social interactions and collaborative problem solving skills while completing open-ended mathematical tasks. It provided distinct entry points for teacher instructional intervention (or scaffolding) in the promotion of CPS skill. The researchers considered that open-ended mathematical tasks were workable in class. However, the novice teachers were not equipped to utilize it in a pedagogically meaningful way, experienced teachers were suggested to be more suitable. This study also mentioned that both collaborative problem solving and negotiated skills should be developed for the contemporary curriculum.

Furthermore, in recent year, the nation has been placing increasing emphasis on the importance of developing student capabilities that are applicable in their daily lives. The OECD (Organization for Economic Co-operation and Development) has stated that from 2015 onward, PISA (the Programme for International Student Assessment) will be assessing students' collaborative problem-solving skills (Serda, 2012). This shows that collaborative problem-solving is an important skill in today's international society. A scientific evaluation emphasizes a student's ability to "explain phenomena scientifically," "identify scientific issues," and "use scientific evidence." Advanced nations are taking PISA results more and more seriously because it serves to compare students' problem-solving abilities on an international scale and can be utilized to inspect the effectiveness of each nation's education policies. Unlike other international competitions on academic subjects, the focuses of PISA are the abilities in life skill application, logical thinking, and problem-solving.

For the aforementioned reasons, this study referenced the key components of the PISA CPS assessment, the content fields for assessing mathematical ability, and key points of implementation for the exclusive design of a PISA evaluative assessment featuring the six key concepts of spatial ability, "Rotation," "Reflection," "Perspective," "Folding," "Stacking," and "Cubic enumeration." The lifestyle-oriented assessment questions incorporated indigenous cultural elements and utilized interactive digital materials designed by the researchers for CPS teaching demonstrations. This enabled the researchers to understand the spatial intelligence of indigenous students and to in turn improve their scientific, mathematic, and collaborative problem-solving skills.

## RESEARCH METHOD

This study is experimental design, and the design of Pre-test and Post-test comparison was used. Students were given pre- and post-test assessments on Atayal culture-based CPS spatial concept teaching activities, the results of which were compiled into data for quantified research. A single group pre- and post-test experimental setup was adopted. The assessment questions were evaluated for effectiveness and reliability and pre-tested by experts to improve the reliability of the lifestyle-oriented assessment questions developed exclusively by the research team.

### Course Planning

Based on CPS teaching strategy, the course developed in this study was divided into the nine following steps: (A) Preparation: preparation by the instructor and learners for team collaboration; (B) the instructors or the learners formed small and heterogeneous working groups to plan the basic procedures for conducting group work; (C) in the initial process, the group would define the problem being solved; (D) each team defined and distributed the roles necessary for the completion of the project; (E) the teams devoted to the main, repetitive CPS processes; (F) the teams started to make a conclusion on a solution or a project; (G) the lesson designer and the learners devoted themselves to activities that helped them reflect upon and integrate their experiences; (H) the instructors and the learners evaluated their achievement and process; (I) the instructors and the learners ended their activities for the learning event.

Six sessions conducted over the course of twelve class hours were taught; each class was 100 minutes in length and consisted of two sections. The six spatial ability concepts, "Rotation," "Reflection," "Perspective," "Folding," "Stacking," and "Cubic enumeration" were included in these courses. Through heterogeneous grouping, each team discussed and learned one specific spatial concept together, after which they presented their findings. Afterwards, instructors assisted the students in reflecting on and integrating their learning experiences. Finally, the learning outcomes were assessed via self-evaluation and teachers' assessments (PISA assessment content, class observation, observation of the use of interactive digital materials).

### Research Subject

The main research subjects were sixteen fifth-grade Atayal elementary students from Nan'ao Township, Yilan County, Taiwan. A lifestyle-oriented assessment test of the students was conducted prior to the teaching demonstration, and another was carried out after completion of the teaching activity. The results underwent dependent Wilcoxon signed-rank test analysis.

**Table 1.** Rank of the six spatial concepts

		<b>N</b>	<b>Mean Rank</b>	<b>Sum of Rank</b>
Rotation post -pre	Native rank	0 <sup>a</sup>	.00	.00
	Positive rank	10 <sup>b</sup>	5.50	55.00
	Ties	2 <sup>c</sup>		
	Total	12		
Reflection post -pre	Native rank	1 <sup>d</sup>	1.50	1.50
	Positive rank	13 <sup>e</sup>	7.96	103.50
	Ties	0 <sup>f</sup>		
	Total	14		
Cubic enumeration post -pre	Native rank	0 <sup>g</sup>	.00	.00
	Positive rank	13 <sup>h</sup>	7.00	91.00
	Ties	2 <sup>i</sup>		
	Total	15		
Stacking post -pre	Native rank	0 <sup>j</sup>	.00	.00
	Positive rank	14 <sup>k</sup>	7.50	105.00
	Ties	1 <sup>l</sup>		
	Total	15		
Perspective post -pre	Native rank	0 <sup>m</sup>	.00	.00
	Positive rank	6 <sup>n</sup>	3.50	21.00
	Ties	8 <sup>o</sup>		
	Total	14		
Folding post -pre	Native rank	0 <sup>p</sup>	.00	.00
	Positive rank	11 <sup>q</sup>	6.00	66.00
	Ties	3 <sup>r</sup>		
	Total	14		
Six spatial concept post -pre	Native rank	0 <sup>s</sup>	.00	.00
	Positive rank	15 <sup>t</sup>	8.00	120.00
	Ties	0 <sup>u</sup>		
	Total	15		

a. Rotation \_post < Rotation \_pre b. Rotation \_post > Rotation \_pre c. Rotation \_post = Rotation \_pre  
 d. Reflection \_post < Reflection \_pre e. Reflection \_post > Reflection \_pre f. Reflection \_post = R Reflection \_pre  
 g. Cubic enumeration \_post < Cubic enumeration \_pre h. Cubic enumeration \_post > Cubic enumeration \_pre  
 i. Cubic enumeration \_post = Cubic enumeration \_pre  
 j. Stacking \_post < Stacking \_pre k. Stacking \_post > Stacking \_pre l. Stacking \_post = Stacking \_pre  
 m. Perspective \_post < Perspective \_pre n. Perspective \_post > Perspective \_pre o. Perspective \_post = Perspective \_pre  
 p. Folding \_post < Folding \_pre q. Folding \_post > Folding \_pre r. Folding \_post = Folding \_pre  
 s. Six spatial concept \_post < Six spatial concept \_pre t. Six spatial concept \_post > Six spatial concept \_pre u. Six spatial concept \_post = Six spatial concept \_pre

### Research Tools

The research tool was a test battery assessment that had been approved and pre-tested (Cronbach  $\alpha = 0.947$ ) by three subject matter experts, and comprised of a formal test sheet on the six spatial concepts, “Rotation,” “Reflection,” “Folding,” “Perspective,” and “Cubic enumeration” with a total of 19 question sets (59 individual questions). Dependent Wilcoxon signed-rank test was conducted on the results of the pre- and post-tests to analyze whether or not significant changes in the spatial conceptualization of indigenous school children had occurred.

### RESEARCH RESULT

A total of sixteen fifth-grade indigenous students participated in the pre- and post-tests of the teaching demonstration and completed the formal assessment test with a total of 19 question sets on the six spatial concepts. The full mark for each test was 100 points. Out of the 19 question sets, nine questions were on “Rotation,” fourteen questions on “Reflection,” seven on “Folding,” twelve on “Perspective,” six on “Stacking,” and eleven on “Cubic enumeration,” totaling 59 individual questions.

Because of the small sample size, the Wilcoxon signed-rank test was used to analyze the data. It was found that after the courses conducted for this study, fifth-grade indigenous students improved test grades both individually and as a group. Their post-test scores were clearly better than the pre-test scores (Table 1). According to the results of the Wilcoxon signed-rank test analysis (Table 2), the six spatial concept score was  $z = -3.41$  and  $p = 0.001$ , showing that a significant difference was achieved between pre- and post-tests in this study. In particular, the difference was extremely remarkable in terms of these three concepts: “Reflection,” “Cubic enumeration,” and “Stacking.”

**Table 2.** Test statistic of the six spatial concepts

	<b>Rotation post -pre</b>	<b>Reflection post -pre</b>	<b>Cubic enumeration post -pre</b>	<b>Stacking post -pre</b>	<b>Perspective post -pre</b>	<b>Folding post -pre</b>	<b>Six spatial concept post -pre</b>
Z test	-2.85	-3.21	-3.19	-3.32	-2.21	-3.02	-3.41
Asymp. Sig. (two tailed)	.004**	.001**	.001**	.001**	.027**	.003**	.001**

\*\*\*p<0.001, \*\*p<0.01, \*p<0.05

## DISCUSSION

In the processing of research, it truly proved the reference about the learning style and characteristics of indigenous children. The indigenous children enjoyed a dynamic, investigation-oriented learning environment with hands-on experiences and cooperation (Tan et al., 2008). Atayal students disliked the lifeless instruction methods and learning materials comprised of symbols and abstractions (Chi & Liu, 2000). It is important to the teachers in tribe elementary schools to apply suitable teaching strategy to fit characteristics of indigenous children.

This study is an idiographic case, the main subjects are Atayal elementary school students in Nan'ao. We designed the CPS spatial concept course and assessment for them according to their culture and environment. Hence, there was the limitations of the area and subjects. Although the learning style and characteristics of indigenous children were common in principle, the researchers who might want to research the same topic should adjust CPS Curriculum design and assessment depending on different area and tribe.

Apart from this, interestingly, indigenous children preferred to complete the classwork by cooperation, but they did not know how to start group discussion and work assignments at beginning of course. It took us a lot of time to lead them to learn teamwork and CPS skills. Because of this, it caused the less efficiency of the course. Our study data also reflected this situation. The course of "Rotation" was the first course, and the difference between pre and post-test was small. As students' CPS skills enhanced, the improvement were more significant.

## CONCLUSION AND SUGGESTION

### Conclusion

This study incorporated the contexts of Atayal culture and took into consideration the learning characteristics of indigenous students in the exclusive design of a course on CPS spatial concepts. At the same time, the accuracy of student performance assessment was also duly considered. As such, a lifestyle-oriented PISA test battery assessment with questions that incorporated indigenous cultural elements and utilized interactive digital materials was exclusively designed by the researchers for CPS teaching demonstrations. This enabled the researchers to understand the spatial intelligence of indigenous students and to in turn improve their scientific learning and problem-solving skills.

After two years of learning, the Atayal indigenous students who participated in the courses improved their scores on the six spatial concepts, "Rotation," "Reflection," "Folding," "Perspective," "Stacking," and "Cubic enumeration." Their learning outcomes showed significant improvement.

### Suggestion

It can be found from literature review that many scholars have been focusing on mitigating the learning difficulties of indigenous students, enhancing their motivation for learning, and improving their learning outcomes. This research project has been conducted at Atayal indigenous schools for many years, and research and development of courses on CPS spatial concepts that incorporate Atayal culture continues to this date. We suggests those who wish to conduct relevant research to consider the learning characteristics of indigenous students and the different cultural contexts of each tribe in combination with currently utilized textbook units for the design of courses that integrate indigenous cultures and appropriate teaching strategies.

In addition, according to the data of this study in the conclusions, CPS strategies of the spatial concept course were effective. But the students didn't know how to make group discussion and work assignments at beginning of course, they spent two years learning by doing and got used to crop with problem by using cps nine steps. In consideration of above, we suggested designing the pre-course about how to do group discussion and work assignments before the beginning of spatial concept course. The pre-course could help students to increases their ability of teamwork and CPS skill. If students already have ability of teamwork and expression, it will make CPS strategies more effective in the process.

Finally, in terms of assessments, an exclusively designed lifestyle-oriented PISA test battery assessment included elements from indigenous culture was utilized. When retrieving the tests, it was found that some indigenous students still lacked patience and answered in a haste, therefore invalidating the assessment results. We suggests that researchers factor in this issue when implementing the assessment; for example, implementing the test over several sittings or selecting the most representative questions could potentially reduce the number of null values.

## REFERENCES

- Chan, M. C., & Clarke, D. (2017). Structured affordances in the use of open-ended tasks to facilitate collaborative problem solving. *ZDM Mathematics Education*, 1(online), 1-13. <https://doi.org/10.1007/s11858-017-0876-2>
- Chang, H. R. (2010). Cooperative Learning Theories. *Internet Sociology and Communications*, 86(14). Retrieved from <http://www.nhu.edu.tw/~society/e-j/86/14.htm>
- Chao, J. Y., Chao, S. J., Yao, L.-Y., & Liu, C. H. (2016). A Case Study of Design and Usability Evaluation of the Collaborative Problem Solving Instructional Platform System. *Eurasia Journal of Mathematics, Science & Technology Education*, 12(10), 2647-2655. <https://doi.org/10.12973/eurasia.2016.1278a>
- Chao, J. Y., Chen, J.-Y., & Chi, S.-C. (2012, Dec). Exploring the differences between learning of indigenous and Han children in the instructional approach of building blocks by hand. *Advances in Education Research*, 9, 332-337. NSC 100-2511-S-130-001
- Chao, J. Y., Liu, C. H., & Chen, J. Y. (2014). The Influence of Courses Integrating Atayal Culture and LEGO Dacta on the Programming Ability and Creativity of Aboriginal Children. *Global Journal of Computers & Technology*, 1(2), 34-43. 305-311.NSC100-2511-S-130-002
- Chao, J. Y., Yao, L. Y., Liu, C. H., & Chen, J. Y. (2015). Study on CPS spatial concept course and assessments for aboriginal children: With “rotation” and “mapping” as examples. In T. H. Meen, S. D. Prior, & A. D. K. T. Lam (Eds.). *Applied system innovation* (pp.163). London: Taylor & Francis Group.
- Chao, J. Y., Yao, L. Y., Liu, C. H., & Chen, J. Y. (2016). Study on CPS spatial concept course and assessments for aboriginal children: With “rotation” and “mapping” as examples. In Meen, Prior, & Lam (Eds.). *Applied system innovation* (pp.735-740). Taylor & Francis Group: London.
- Chi, H. Y., & Liu, H. L. (2000). The Learning World of Atayal Children in Elementary Schools. *Journal of National Hualien Teachers College*, 10, 65-100.
- Chou, Y. S., Huang, T. H., & Yu, P. T. (2015). The Influences of the Application of Animation Teaching toward Aboriginal Students’ Aesthetic Experience. *Educational Technology & Learning*, 3(1), 1-24.
- Department of Statistics, Ministry of the Interior (2015). *Statistical Bulletin, Week 7, 2015* (Summary of indigenous population by the end of 2014). Retrieved from [http://www.moi.gov.tw/stat/news\\_content.aspx?sn=9235](http://www.moi.gov.tw/stat/news_content.aspx?sn=9235)
- DeWitt, D., Alias, N., Siraj, S., & Spector, J. M. (2017). Wikis for a Collaborative Problem-Solving (CPS) Module for Secondary School Science. *Educational Technology & Society*, 20(1), 144-155
- Fu, L. Y. (2004). Whose Scientific Education? A Multicultural Perspective on Elementary and Middle School Scientific Education. *Courses and Teaching*, 7, 91-108.
- Ho, Y. C. (2005). Practice and Reflection of Culturally Responsive Teaching: Action Research of a Multi-Ethnic Classroom. *Journal of the National Institute for Compilation and Translation*, 33(4), 30-41.
- Huang, J. J. S., Yang, S. J. H., Chiang, P. Y. F., & Tzeng, L. S. Y. (2012). Building an e-portfolio learning model: Goal orientation and metacognitive strategies. *Knowledge Management & E-Learning: An International Journal*, 4(1), 16-36.
- Karpov, Y. V., & Haywood, H. C. (1998). Two ways to elaborate Vygotsky’s concept of mediation: Implications for instruction. *American Psychologist*, 53(1), 27-36. <https://doi.org/10.1037/0003-066X.53.1.27>
- Kim, H., & Song, J. (2006). The Features of peer argumentation in middle school students’ scientific inquiry. *Research in Science Education*, 36(3), 211-233. <https://doi.org/10.1007/s11165-005-9005-2>
- Lin, L. C. (1994). Interactive Learning Environments and the Learning of Scientific Knowledge. *Instructional Technology & Media*, 16, 3-13.
- Linn, M. C., & Petersen, A. C. (1985) Emergence and characterization of sex in spatial ability: a meta-analysis. *Child Development*, 56, 1479-1498. <https://doi.org/10.2307/1130467>
- Lohman, D. F. (1988). Spatial abilities as traits, processes, and knowledge. In *Advances in the psychology of human intelligence*, R. J. Sternberg, Ed. Hillsdale, NJ: Lawrence Erlbaum Associates, 181-248.
- Lord, T. R. (1985a). Enhancing learning in the life sciences through spatial perception. *Innovative Higher Education*, 15(1), 5-16. <https://doi.org/10.1007/BF00889733>

- Lord, T. R. (1985b). Enhancing the visuo-spatial aptitude of students. *Journal of Research in Science Teaching*, 22(5), 395-405. <https://doi.org/10.1002/tea.3660220503>
- McGee, M. G. (1979) Human spatial abilities: Psychometric studies and environmental, genetic, hormonal, and neurological influences. *Psychological Bulletin*, 86(5), 889-918. <https://doi.org/10.1037/0033-2909.86.5.889>
- Nelson, L. M. (1999). Collaborative problem solving. In *Instructional-design theories and models: A new paradigm of instructional theory*, C. M. Reigeluth. Ed. Mahwah, N.J.: Erlbaum Associates.
- Serda, G. (2012, Oct. 26). PISA will assess collaborative problem solving skills in 2015 acknowledges ATC21S program. [Web blog message]. Retrieved from <http://blogs.cisco.com/education/57226>
- Tan, K. T., Liu, M. H., & Yu, M. H. (2008). *Multicultural Education*. Taipei, Taiwan: Higher Education.
- Wang, J. U., & Chen, K. H. (2016). Based on Cabri 3D and Physical Manipulatives to Study the Effect of Learning on the Spatial Rotation Concept for Second Graders. *Taiwan Journal of Mathematical Education*, 3(1), 19-54.
- Weckbacher, L., & Okamoto, Y. (2014). Mental rotation ability in relation to self-perceptions of high school geometry. *Learning & Individual Differences*, 30, 58-63, <https://doi.org/10.1016/j.lindif.2013.10.007>
- Wu, H. C. (2001). *A study of the Relationship between the Performances of Spatial Ability and Learning Achievement of Development Drawing in the Mechanical Drawing of Vocational High School Student* (Unpublished M.S. thesis). Dept. Industrial Education, National Taiwan Normal Univ., Taipei, Taiwan.

**<http://www.ejmste.com>**



## How do College Students Clarify Five Sample Spaces for Bertrand's Chord Problem?

Bongju Lee <sup>1</sup>, Yong Sik Yun <sup>2\*</sup>

<sup>1</sup> Kyungpook National University, Daegu, SOUTH KOREA

<sup>2</sup> Jeju National University, Jeju, SOUTH KOREA

Received 18 May 2017 • Revised 17 December 2017 • Accepted 7 February 2018

### ABSTRACT

The concept of probability has a unique characteristic that causes confusion when a sample space is not clearly defined. This inherent nature of probability has been demonstrated in Bertrand's chord problem, which is well-known as the paradox of probability theory. This study demonstrated that a single probability in Bertrand's chord problem can be obtained by modifying it to clearly redescribe its sample space, and examined that how college students clarify the sample space. To this end, five modified questions were formed using Bertrand's chord problem to ensure that the sample space of each question was clearly expressed and were used to develop a survey questionnaire. The participants of the survey were 68 college students studying mathematics or mathematics education. The results of this study demonstrated that many college students have difficulty to seek out the sample spaces in some probability problems. Thus we suggested the importance of emphasizing to clarify the sample space in probability education.

**Keywords:** Bertrand's chord problem, paradox, college students, five modified Bertrand's questions, probability, sample space

### INTRODUCTION

Probability is a relatively familiar term that is widely used in this information age. For instance, the question 'what is the probability of obtaining heads when flipping a coin?' is asked ordinarily and most people answer " $\frac{1}{2}$ ". This is because most people approach the question by thinking that a coin has a heads side and a tails side and the chance of the coin falling either heads or tails is the same.

However, it is debatable whether the heads and tails sides of a coin are indeed obtained under the same condition or not. The designs on the heads and tails sides of a coin are different and it is uncertain whether the specific gravity in the coin is evenly distributed. One aspect that must be understood in the experiment of flipping a coin is that the assessment "the probability of each side is the same because they exist under the same condition" is not an absolute truth, but a selected assumption. In other words, the  $\frac{1}{2}$  probability of obtaining heads is not a transcendental and absolute truth, but it results from the assumption that each case has the same chance of occurring (Batanero, Henry, & Parzysz, 2005; Kim, 2008; Rubel, 2007; Woo, 1998).

Accordingly, the concept of transcendental and absolute probability does not exist. The classical definition of probability provided by Laplace in the 19<sup>th</sup> century, the so-called mathematical probability, is based on the fundamental premise that each element within a sample space has the same chance of occurring (Alexander & Kelly, 1999; Gauvrit & Morsanyi, 2014; Gillies, 2000; Woo, 1998). According to the classical interpretation, probability is defined as the ratio of the number of elements of a certain event to the number of the elements of the sample space, and geometrical probability typically fits this interpretation as well (Lee, 1997). Considering this classical interpretation of probability, the importance of clarifying whether each element within the sample space is under the same condition has been widely recognized and is highlighted in school education (Batanero & Borovcnik, 2016; Garfield & Ahlgren, 1988). Many studies reported important results on students' probabilistic

### Contribution of this paper to the literature

- This study provides a new perspective on Bertrand's chord problem in that it approaches as a sample space.
- We highlight the importance of guiding to clarify sample space in probability education.
- This study shows some limits to the mathematical definition of probability can be overcome by clearly defining fundamental events with equiprobability.

thinking (e.g., Agus, Peró-Cebollero, Penna, & Guàrdia-Olmos, 2015; Fischbein & Gazit, 1984; Fischbein & Schnarch, 1997; Green, 1983; Hawkins & Kapadia, 1984; Konold, 1989; Kwon & Lee, 2015; Kwon, Kim, & Lee, 2014; Rubel, 2007; Shaughnessy, 1977). Some researchers emphasized and focused on sample space that plays an important role in probabilistic tasks and situations (e.g., Chernoff, 2009; Chernoff & Zazkis, 2011; Jones, Langrall, & Mooney, 2007; Jones, Langrall, Thornton, & Mogill, 1997, 1999; Shaughnessy, 1998).

Despite these researchers' emphasizing the sample space, recently, Choi, Yun, and Hwang (2014) reported that pre-service mathematics teachers still have the difficulty to understand the sample space. They proposed that students should be provided with the opportunity to think about the sample space in probability and statistics education. We suggest that teacher educators and teachers would use Bertrand's chord problem as one of these opportunities. That's because we saw both groups of pre-service and in-service mathematics teachers who didn't understand the solutions of Bertrand's chord problem in our classrooms. Many college students and mathematics teachers didn't understand why there exist three solutions for this problem and why it is called a paradox. We thought that's because they didn't have the chance to meet its solutions exposing the term sample space although each solution represents chance and inherent equiprobability. Like this, the mathematical definition of probability can cause further confusion unless clearly defining the fundamental events that have equiprobability in probability space. Lee (1997) and Woo (1998) noted that this paradox is the limits to the mathematical interpretation of probability with its classical definition. In this article, we would represent the term Bertrand's chord problem instead of Bertrand's paradox.

With this backdrop, this study used Bertrand's chord problem to demonstrate that the limits to the mathematical definition of probability in some probability problems can be overcome by clarifying the sample space, and to emphasize that it is important to teach students to clearly define the sample space in probability problem. To this end, each solution of Bertrand's chord problem was represented using the term sample space and this problem was modified in five ways to ensure the existence of only one sample space. These modified problems were given to college students studying mathematics and mathematics education to demonstrate that how well they could clarify the sample spaces and obtain a single probability.

## BACKGROUND

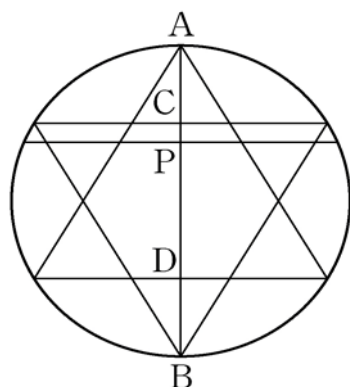
### Discussion of Bertrand's Chord Problem

Bertrand's chord problem has been discussed by many researchers (Aerts & Sassoli de Bianchi, 2014; Borovcnik, Bentz, & Kapadia, 1991; Drory, 2015; Gyenis & Rédei, 2014; Jaynes, 1973; Klyve, 2013; Marinoff, 1994; Porto, Crosignani, Ciattoni, & Liu, 2011; Rowbottom, 2013) since Bertrand introduced it in 1889. Bertrand's chord problem using Bertrand's words is as follows.

*Bertrand's chord problem. We draw at random a chord onto a circle. What is the probability that it is longer than the side of the inscribed equilateral triangle? (Aerts & Sassoli de Bianchi, 2014, p. 1)*

Bertrand (1889) proposed this problem which leads to the different results  $P(A) = \frac{1}{2}$ ,  $P(B) = \frac{1}{3}$ , and  $P(C) = \frac{1}{4}$ . These probabilities are according to each of the three assignments for 'equally possible situations': (A) the linear line between centers of chord and circle, (B) angles of intersections of the chord on the circumference, and (C) the center of the chord over the interior area of the circle (Jaynes, 1973). Even though Bertrand presented three answers for it, Jaynes (1973) concluded that Bertrand's chord problem is well posed and has the unique probability  $P(A) = \frac{1}{2}$ . This conclusion was followed by his viewpoint toward probability theory that "the only valid basis for assigning probabilities is frequency in some random experiment (p. 2)". Using an analogy with a cylindrical cake cutting, Rowbottom (2013) also insisted that Bertrand's original problem is vague and all Bertrand's three solutions are not the effective potential ways.

Other researchers who had referenced Bertrand's problem supported Bertrand's three different solutions. Borovcnik, Bentz, and Kapadia (1991) described that each of the three solutions shows chance determined by the equiprobability of Laplace's definition through its individual random generator. Marinoff (1994) showed Bertrand's chord problem is equivocally brought up but the many versions of Bertrand's original problem by clearly stated



**Figure 1.** A chord vertical to diameter AB

variations lead to different solutions can be solved. Porto, Crosignani, Ciattoni, and Liu (2011) basically accepted that Bertrand's results are all correct as well as many other possible ones because a chord drawing randomly cannot be uniquely defined. They provided a realistic physical experiment associating with it as alternative to Bertrand's chord problem. Furthermore, Klyve (2013) defended Bertrand's intention against Rowbottom (2013)'s interpretation of Bertrand's chord problem. Klyve noted that Rowbottom misinterpreted what Bertrand said about the random chord although his conclusion is correct according to his own description. **Drory (2015) discussed that it has inherent ambiguity and depends on explicitly defining the selection procedure for the random chords.**

Meanwhile, Aerts and Sassoli de Bianchi (2014) showed that Bertrand's chord problem includes an easy problem and a hard problem. They reported that the easy problem is solvable by clarifying Bertrand's chord problem in precise terms. They presented one example for a specific physical realization of Bertrand's chord problem which has the same to three different answers proposed by Bertrand, and then insisted that Bertrand's three solutions should be more easily explained via three different conditional probabilities. Thus, Aerts and Sassoli de Bianchi concluded that Bertrand's chord problem should not anymore be considered as a paradox. Also, they remade the hard problem using modified Bertrand's chord problem in that two points instead of a straight line are randomized. This hard problem became solvable by calculating a uniform average, which they called a universal average, over all possible ways of selecting an interaction.

Unlike above researchers who focused on Bertrand's chord problem's solutions and answers, Gyenis and Rédei (2014) suggested a new interpretation of it and investigated the relation between Bertrand's chord problem and the classical interpretation of probability. They argued that this paradox is harmonized with how the science uses mathematical probability theory to model phenomena, without making any damage the principle of indifference and the classical interpretation of probability.

### Solutions to Bertrand's Chord Problem using the Term Sample Space

In general, many researchers and practitioners cited three typical solution methods that lead to the results  $\frac{1}{2}$ ,  $\frac{1}{3}$ ,  $\frac{1}{4}$  (see, Aerts & Sassoli de Bianchi, 2014; Borovcnik, & Bentz, 1991, Drory, 2015; Lee, 1997; Marinoff, 1994; Porto et al., 2011; Woo, 1998). Kim (2008) introduced other two other solutions which lead to the results of impossibility and indefinite, respectively. However, they described the results and probabilities without using the term sample space in three different solutions for it. In this section, we tried below five solutions to help mathematics teachers and students understand the solutions of Bertrand's chord problem in terms of sample space. Also, these were supposed to be the basis of five modified Bertrand's chord questions given as testing tool in the next section.

**Solution 1.** Suppose that a line segment passes through midpoint D of the opposite side of the vertex A of an equilateral triangle inscribed in a circle, as shown in **Figure 1** and that the point where the line segment meets with the circle is B. Assume that the set of all chords that are perpendicular to line segment AB is the sample space. The length of such perpendicular chords in this probability space is determined by the location of point P, which is defined by the intersection of line segment AB with a perpendicular chord.

Suppose that C is a point where line segment AB meets with a chord that has the same length as the triangle side within the sample space and that C is not located on the opposite side of vertex A. When a point P lies on line segment CD, the length of the chord is greater than the side of the equilateral triangle inscribed in the circle. In other words, the probability in this case is the same as the probability that point P is on line segment CD. Therefore, the length of line segment CD is  $\frac{1}{2}$  of the length of diameter AB. Therefore, we obtain a probability of  $\frac{1}{2}$ .

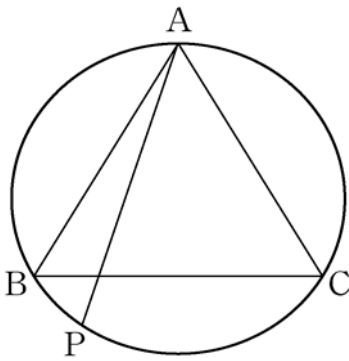


Figure 2. A chord fixed at point A

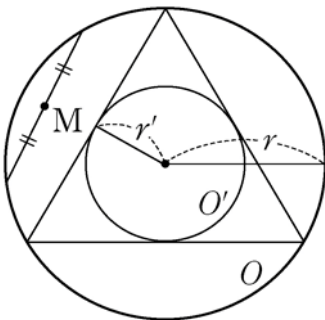


Figure 3. A chord with a midpoint M

**Solution 2.** As a chord is determined by two points on a circumference, consider the vertex A of an equilateral triangle inscribed in a circle as one endpoint of a chord, as shown in Figure 2. Suppose that the set of all chords that are drawn from vertex A is the sample space of a probability space. The chords included in this probability space are determined by the location of their other endpoints Ps.

Suppose that the other two vertices of the triangle inscribed in the circle are B and C. When the endpoint P of a chord is on arc BC, the length of the chord is greater than the side of the triangle inscribed in the circle. In other words, the probability in this problem is the same as the probability that point P is on arc BC. Therefore, the length of arc BC is  $\frac{1}{3}$  of the length of the circumference. Therefore, the probability is  $\frac{1}{3}$ .

**Solution 3.** Suppose that the midpoint of a randomly drawn chord is M, as shown in Figure 3, and that the radius of a circle inscribed in an equilateral triangle is  $r'$ . A circle circumscribed about the equilateral triangle is denoted by O and the circle with radius  $r'$  by  $O'$ . The probability of the question is the same as the probability that the midpoint M is within the circle  $O'$  in a probability space of which a sample space is defined as a set of midpoints M of randomly drawn chords. Therefore, the area of circle  $O'$  is  $\frac{1}{4}$  of the area of circle O. Therefore, this probability is  $\frac{1}{4}$ .

**Solution 4.** Suppose that a line segment passes through the midpoint of the opposite side of the vertex A of an equilateral triangle inscribed in a circle and that this line segment meets the circle at point B, as shown in Figure 4. Draw a tangent line  $l$  that passes through point B. Suppose that an extension of chord AP having A as one endpoint meets with tangent line  $l$  at the point  $P'$ . Each chord AP has a one-to-one correspondence with each point  $P'$  on tangent line  $l$ . In other words, the statement "draw chord AP from vertex A" is equivalent with "select point  $P'$  on tangent line  $l$ ". Therefore, suppose that the set of all points defined by the intersections of the extensions of all chords drawn from vertex A of the triangle with tangent line  $l$  is the sample space of a probability space. The chords contained in this probability space are determined by the locations of points  $P'$ s.

Suppose an equilateral triangle ACD inscribed in a circle and that the contact points of the extensions of the two chords AC and AD with tangent line  $l$  are  $C'$  and  $D'$ , respectively. When the contact point of the extension of a chord with tangent line  $l$  lies on line segment  $C'D'$ , the length of the chord is greater than the side of the equilateral triangle. In this case, however, the length of the line of the sample space is infinite; thus, if its probability is defined by the length, this leads to a contradiction. Therefore, it is impossible to solve the problem under this condition.

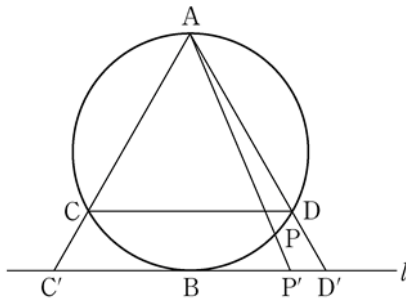


Figure 4. A point where the extension of a chord fixed at a point on a circle meets with a tangent line

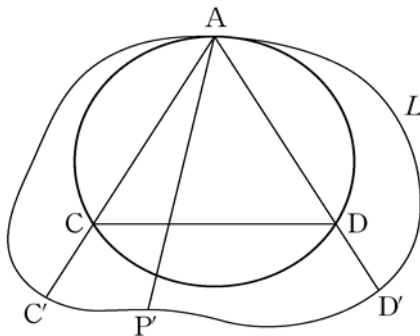


Figure 5. A point where an extended line of a chord fixed at a point on a circle meets with a closed curve

**Solution 5.** Suppose that a closed curve with length  $L$  is circumscribed in a circle and touches the circle at the vertex  $A$  of an equilateral triangle, as shown in Figure 5. As the extension of a chord has a one-to-one correspondence with the contact point on the closed curve, like in Solution 4, suppose that the sample space of a probability space is the set of all points defined by the intersections of the extensions of all chords drawn from  $A$  with the closed curve. The chords included in this probability space are determined by the locations of points  $P$ 's.

Consider an equilateral triangle  $ABC$  inscribed in a circle and that the contact points of the extensions of the two chords  $AC$  and  $AD$  with the closed curve are  $C'$  and  $D'$ , respectively. When the contact point of the extension of a chord with the closed curve is on curve segment  $C'D'$ , the length of the chord is greater than the side of  $\triangle ABC$ . Suppose that the length of curve segment  $C'D'$  is  $l$ , the length of the closed curve is  $L$ , and the length of a partial curve is  $l$ . Therefore, the probability is  $\frac{l}{L}$ . However, considering that the closed curve circumscribed from point  $A$  can be randomly drawn, the lengths  $L$  and  $l$  can vary. Therefore, the answer is indefinite.

As shown by the five solutions above, the cause of confusion in Bertrand's chord problem results from the ambiguous expression 'a chord randomly drawn', which does not clarify 'in which probability space its probability distribution is provided' or 'which fundamental events occur under the same condition'. In other words, this shows the importance of clarifying the premise of a sample space under the same condition in Bertrand's chord problem. Against this backdrop, we discussed below how well college students clarify each sample space in five modified Bertrand's chord questions asking a single answer.

## METHODS

### Testing Tool

We modified Bertrand's chord problem to clearly show five fundamental events that have the same possibility to occur; in other words, to clearly find out the sample space which was intended in each question. Using the testing tools shown in Table 1, this study investigated how well the college students could correctly determine the sample space and the probability that satisfies the conditions of individual questions. We provided appropriate figure in each modified problem to help students find out all chords which were intended as the elements of the sample space.

The sample spaces designed in five modified questions in Table are as follows. In question No. 1, the sample space is defined as the set of all chords perpendicular to a fixed diameter of a circle. In question No. 2, the sample space is defined as the set of all chords drawn from one fixed vertex of a triangle. In question No. 3, the sample space is defined as a set collecting all midpoints  $M$ s of randomly drawn chords. In question No. 4, the sample space

**Table 1.** Testing questions

Questions	
<p>1. Suppose that a line segment passes through the midpoint <math>D</math> of the opposite side of the vertex <math>A</math> of an equilateral triangle inscribed in a circle and that the line segment meets the circle at point <math>B</math>, as shown in the figure on the right. What is the probability that the length of a chord whose extension is drawn perpendicularly to diameter <math>AB</math> is longer than the side of the triangle?</p>	
<p>2. Suppose a chord that defined by a random point <math>P</math> on the circumference of a circle and by the vertex <math>A</math> of an equilateral triangle inscribed in the circle, as shown in the figure. What is the probability that the length of a chord is greater than the side of the triangle inscribed in the circle?</p>	
<p>3. Suppose an equilateral triangle inscribed in circle <math>O</math> and another circle <math>O'</math> inscribed in the triangle. What is the probability that the midpoint <math>M</math> of a random chord of circle <math>O</math>, as shown in the figure, is located inside circle <math>O'</math>?</p>	
<p>4. Consider an equilateral triangle <math>ACD</math> inscribed in a circle, as shown in the figure, and the tangent line <math>l</math> that is parallel to side <math>CD</math>. Suppose that the contact points of sides <math>AC</math> and <math>AD</math> with tangent line <math>l</math> are <math>C'</math> and <math>D'</math>, respectively. If a chord <math>AP</math> starts from vertex <math>A</math> and passes through a random point <math>P</math> on the circumference of the circle, what is the probability that the contact point <math>P'</math> of line <math>AP</math> with tangent line <math>l</math> is located on line segment <math>C'D'</math>?</p>	
<p>5. Consider an equilateral triangle <math>ACD</math> inscribed in a circle, as shown in the figure, and a random closed curve <math>L</math> circumscribed in a circle that contacts the circle at vertex <math>A</math>. Suppose that the contact points of lines <math>AC</math> and <math>AD</math> with curve <math>L</math> are <math>C'</math> and <math>D'</math>, respectively. If line <math>AP</math> starts from vertex <math>A</math> and passes through a random point <math>P</math> on the circumference of the circle, what is the probability that the contact point <math>P'</math> of line <math>AP</math> with the closed curve is located on curve segment <math>C'D'</math>?</p>	

is presented as the set of all intersection points where the extensions of all chords drawn from vertex  $A$  of the triangle meet with tangent line  $l$ . In question No. 5, the sample space is the set of all intersection points where the extensions of all chords drawn from the fixed vertex  $A$  of a triangle meet with the closed curve.

### Participants

An offline survey using the above testing tools was planned to be conducted for the 3<sup>rd</sup>- and 4<sup>th</sup>-year students who major mathematics or mathematics education at the J national university. We recruited 68 volunteered students to participate in this survey using two department bulletin boards during one week. Table 2 shows the information of the survey participants, including their major subject, grade, and gender. Among the participants, the numbers of the 3<sup>rd</sup>- and 4<sup>th</sup>-year college students were 45 and 23, respectively. Three of the 68 participants responded that they had studied Bertrand's chord problem before and the remaining 65 students that they had not studied it yet.



**Table 2.** Participants

Major	Year		Gender		Total
	3rd	4th	Male	Female	
Mathematics	28	23	28	23	51
Mathematics Education	17	0	7	10	17
Total	45	23	35	33	68

**Table 3.** Distribution of responses to modified Question No. 1

Answers	1/2	1/3	1/4	Other incorrect answers	Non Response	Total
Frequency	49	4	4	7	4	68
Percentage	72	6	6	10	6	100

## Data Collection and Analysis

The survey was conducted in their department lecture rooms in October 2014. The survey date depended on grades and major. The participants were supplied with the survey questionnaire and were instructed to solve the questions in the given order and not to change their solution process and answers; this method was intended to clarify how well they approach individual questions. The total response time for the five questions was unlimited to ensure that the students could provide their answers without restrictions.

To analyze how well the students responded on the five modified Bertrand's chord questions, we input their all answers in Microsoft Office Excel and calculated the frequency and the response percentage on each answer. We also qualitatively analyzed their incorrect answers to interpret how they approached to each question and to infer whether they had errors in selecting a sample space or in the concept of probability itself. We presented the students' wrong solutions as real examples.

## RESULTS AND DISCUSSION

### Responses to Modified Question No. 1

Question No. 1 was modified to define a set containing all chords perpendicular to a fixed diameter of a circle as the sample space. The distribution of the students' responses was as shown in Table 3. Approximately 72% of the surveyed students answered that the probability was  $\frac{1}{2}$ . In addition, two of the three students who responded that they had studied Bertrand's chord problem before answered " $\frac{1}{2}$ " and the rest did not respond to Question No. 1. This indicated that most of the surveyed students could solve the probability question without much confusion when the sample space was defined as the set of all chords perpendicular to a fixed diameter of the circle.

Because all incorrect answers, except one incorrect answer of 0, were presented without any information on the solution process, it was difficult to determine the causes of errors. We just could infer that they would have any difficulty to solve some geometrical probability problems or to understand some mathematical concepts involved in this question. The student who answered "0" considered a right-angled triangle inscribed in the circle instead of an equilateral triangle, owing to a lack of understanding of the question.

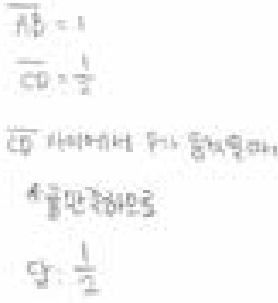
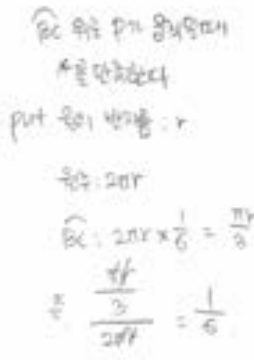
### Modified Question No. 2

Question No. 2 was modified to define the sample space as a set of all chords drawn from one vertex of a triangle. The participants' response distribution was as shown in Table 4. Approximately 72% of the surveyed students answered that the probability was  $\frac{1}{3}$ . In addition, all three students who had studied Bertrand's chord problem before answered " $\frac{1}{3}$ ". Among the 49 students who answered correctly to Question No. 1, 40 students answered correctly again. In other words, approximately 59% of the total surveyed students answered correctly both to Questions Nos. 1 and 2. This indicated that the surveyed students could solve the probability question without much confusion when its sample space was defined as the set of all chords drawn from one vertex of the triangle.

**Table 4.** Distribution of responses to modified Question No. 2

Answers	1/2	1/3	1/4	Other incorrect answers	Non Response	Total
Frequency	3	49	2	9	5	68
Percentage	5	72	3	13	7	100

**Table 5.** The case of a student who answered correctly to Question No. 1 and incorrectly to Question No. 2

Correct answer to No.1	Incorrect answer to No.2
 <p> <math>\overline{AB} = 1</math>  <math>\overline{CD} = \frac{1}{2}</math>  <math>\overline{CD}</math> 위에서 P가 움직일 때                      * is satisfied.                      Therefore, the correct answer is <math>\frac{1}{2}</math> </p>	 <p> <math>\overline{AB} = 1</math>  <math>\overline{CD} = \frac{1}{2}</math>                      When P moves on <math>\overline{CD}</math>,                      * is satisfied.                      Therefore, the correct answer is <math>\frac{1}{2}</math> </p> <p>                     Arc BC: <math>2\pi r \times \frac{1}{6} = \frac{\pi r}{3}</math>  <math>\frac{\frac{\pi r}{3}}{2\pi r} = \frac{1}{6}</math> </p>

**Table 6.** Distribution of responses to modified Question No. 3

Answers	1/2	1/3	1/4	Other incorrect answers	Non Response	Total
Frequency	30	7	13	13	5	68
Percentage	44	10	19	19	7	100

To determine the causes of the incorrect answers to Question No. 2 of those who answered correctly to Question No. 1, their processes of solving the two questions were reviewed. **Table 5** shows the answers of one student who answered correctly to Question No. 1 but incorrectly to Question No. 2. This shows that some students made an error in calculating the length of the partial curve that meets the conditions, not in selecting a sample space or one related to the concept of probability.

### Modified Question No. 3

Question No. 3 was modified to define a set containing the midpoints of all random chords as the sample space; the response distribution is shown in **Table 6**. The number of students who correctly answered " $\frac{1}{4}$ " to Question No. 3 was a mere 19% of the total sample. In addition, only one of the three students who had studied Bertrand's chord problem before answered " $\frac{1}{4}$ " and the other two answered " $\frac{1}{2}$ " and " $\frac{1}{3}$ ". In particular, only seven of the 13 participants who answered correctly to Question No. 3 also answered correctly both to Questions No. 1 and No. 2. This indicates that more than 80% of the surveyed students calculated the probability in Question No. 3 incorrectly.

Unlike the two previous questions, Question No. 3 showed a relatively high incorrect answer rate. To determine the cause of this observation, some notable incorrect cases were reviewed, as shown in **Table 7**.

The cases (A) and (B) were the most common as participants' answers of this question. It was possible to assume that most of the students who incorrectly answered had a difficulty in finding the sample space of this question. These students revealed the error of recognizing only a part of the sample space intended in this question because they did not consider all random chords and limited it to the set of some chords. In other words, these students could understand the concept of probability but had difficulty to clarify the sample space satisfying the condition. From this result, we could reconfirm the reason why many pre-service and in-service mathematics teachers had difficulty to focus on the position of midpoint M which uniquely determines the chord among original three solutions of Bertrand's chord problem. It can be inferred that they had difficulty to seek out the set to all midpoints because of not considering all random chords.

In the cases (C) and (D), only one student answered incorrectly, as shown in the **Table 7**; the student succeeded in defining the sample space but made errors in calculating probability and in determining the figure of the event.

**Table 7.** Cases of incorrect answers to Question No. 3

Cases	Error analysis
<p>(A)</p> <p>그런데서야 점과 평행한 평행 선을                  현의 중심이 원 O'안에 있을 확률은  <math display="block">\frac{\text{작은 원의 지름}}{\text{큰 원의 지름}} = \frac{1}{2}</math></p> <p>Consider chords that are parallel with the chord shown in the figure. The probability that the midpoints of these chords are located within circle O':  <math display="block">\frac{\text{diameter of the small circle}}{\text{diameter of the large circle}} = \frac{1}{2}</math></p>	<p>It shows error in determining the sample space and event. The participant failed to consider random chords and defined a set of the midpoints of chords that are parallel with the chord shown in the figure as the sample space.</p>
<p>(B)</p> <p>점 A를 거나는 현의 중점들은                  현의 중심이 원 O'안에 있으면                  현이 AB와 AC 사이에서                  존재해야 하므로  <math display="block">\frac{60^\circ}{180^\circ} = \frac{1}{3}</math></p> <p>When defining chords that pass through point A, chords should be located between <math>\overline{AB}</math> and <math>\overline{AC}</math> to have their midpoints located within circle O'.                  Therefore, <math>\frac{60^\circ}{180^\circ} = \frac{1}{3}</math></p>	<p>It shows error in determining the sample space and events like the case (A). The participant failed to consider random chords and defined the sample space as a set of the midpoints of the chords that had one endpoint fixed at one vertex of the triangle.</p>
<p>(C)</p> <p>M이 원 O' 안에 있다                  M의 중심이 O인 원의 넓이  <math>a^2\pi</math>                  O'의 넓이는  <math>\frac{1}{16}a^2\pi</math>  <math>\therefore</math> 확률: <math>\frac{1}{16}</math></p> <p>M is located within circle O'.                  The area of a circle with radius <math>a</math> is <math>a\pi^2</math>.                  The area of circle O' is <math>\frac{1}{16}a^2\pi</math>.  <math>\therefore</math> Probability: <math>\frac{1}{16}</math></p>	<p>Participant successfully determined the sample space and event but made an error in the process of calculating the area of the circle inscribed in the triangle.</p>
<p>(D)</p> <p>사) 현의 중점과 현의 대변 대응이다                  또 O와 O'의 반지름은 각각 r, r'이라 하면  <math>r:r' = 2:1</math> 이므로 원의 넓이 <math>S(O):S(O') = 4:1</math>                  현의 중심이 O-O'의 변위 내에 있으려면                  확률은 <math>\frac{3}{4}</math></p> <p>The midpoints of the chords correspond one-to-one with the chords.                  If the radius of circles O and O' are <math>r, r'</math>, respectively, then <math>r:r' = 2:1</math>                  Thus, the areas of the circles are <math>S(O):S(O') = 4:1</math>.                  The probability that the midpoints of the chords are located within the O – O' range is <math>\frac{3}{4}</math></p>	<p>The participant succeeded in defining the sample space but made an error in the process of calculating the figure of the event.</p>

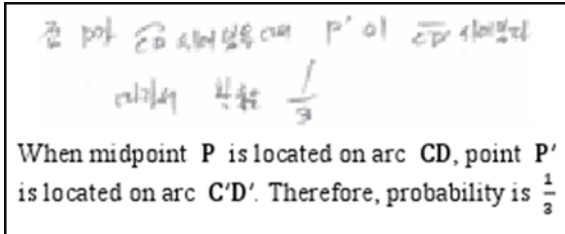
Considering these results, we conclude that most of the students who answered incorrectly had difficulties in defining the sample space and event in this question, which is essential to calculate geometrical probability.

### Modified Question No. 4

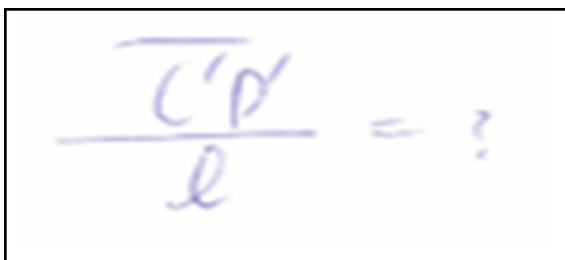
Regarding modified Question No. 4, it is impossible to define the probability owing to the infinite length of a line of the sample space. The response distribution of the surveyed students was as shown in **Table 8**. Approximately 74% of the participants answered " $\frac{1}{3}$ " incorrectly. No student answered that it was impossible to

**Table 8.** Distribution of responses to modified Question No. 4

Answers	1/2	1/3	1/4	Other incorrect answers	Non Response	Total
Frequency	1	50	3	7	7	68
Percentage	2	74	4	10	10	100



**Figure 6.** Case of incorrect answer Question No. 4



**Figure 7.** Case of correctly finding the sample space Question No. 4

**Table 9.** Distribution of responses to modified Question No. 5

Answers	1/3	Similar answers	Other incorrect answers	Non Response	Total
Frequency	45	1	10	12	68
Percentage	66	2	14	18	100

define a sample space satisfying the axiom of probability in this question. This result seems to be attributable to the fact that cases with infinite length and the area of a sample space had not been addressed in the process of teaching the concept of probability.

The case shown in **Figure 6** indicates the reason why most of the surveyed students answered “ $\frac{1}{3}$ ” to this question. This case shows that most of participants failed to recognize the set of the contact points  $P'$  between lines  $AP$  and tangent lines  $l$  as the sample space of this problem. In other words, they made an error in recognizing the set of the endpoints of all the chords drawn from the vertex  $A$  of the triangle as the sample space, like in modified Question No. 2.

However, one student determined the sample space and event correctly, as shown in **Figure 7**. The student understood that the sample space in this question was the line segment  $C'D'$  on the tangent line but failed to calculate the probability because the length of the line starting from vertex  $A$  was  $\infty$  and the length of the line segment was finite.

### Modified Question No.5

In terms of modified Question No. 5, the probability is indefinite because the closed curve, the sample space in this case, is circumscribed at point  $A$  and it can be randomly drawn. The response distribution of the surveyed students was as shown in **Table 9**. Approximately 66% of the participants answered “ $\frac{1}{3}$ ” incorrectly and most of them failed to correctly determine the sample space and event, like in modified Question No. 4. Unlike in Question No. 4, some students correctly described the probability as a generalized ratio of the length of the figure of the sample space to the figure of the event.

The reason why most of the surveyed students answered “ $\frac{1}{3}$ ” to this question can be assumed from the case shown in **Figure 8**. This case shows that most of the participants failed to recognize the set of the contact points  $P'$ s between lines  $AP$  and the closed curve as the sample space in this case, like in Question No. 4. In other words, they

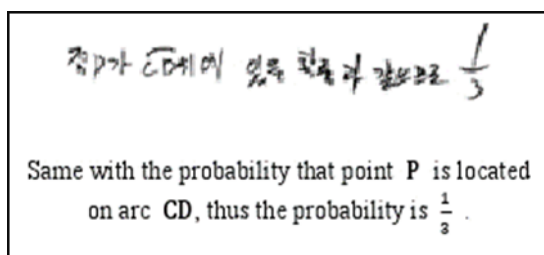


Figure 8. Case of incorrect answer Question No. 5

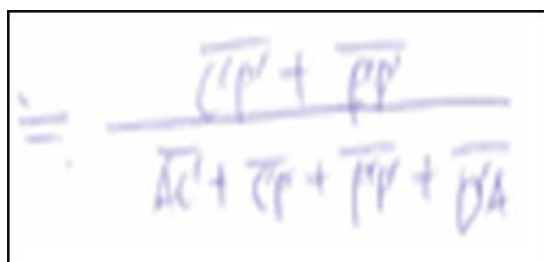


Figure 9. Case of correctly finding the sample space Question No. 5

made the same error as in Question No. 4. However, some students determined the sample space and event correctly and generalized the probability, as shown in Figure 9.

In Figure 9, the student correctly understood that the sample space was a random closed curve and that the event was the union of partial curves of this closed curve. This particular student also correctly determined the sample space in Question No. 4 and had not studied Bertrand’s chord problem before. These results show that most of the students had difficulties in seeking out the sample space which was intended in the question, which is essential for defining the probability in some cases.

### CONCLUSION AND IMPLICATIONS

The concept of probability has a unique characteristic that causes confusion when no clear definition is provided for the sample space, which is a universal set of elements with the same chance to occur. We can identify this inherent nature of probability via Bertrand’s chord problem, which is known as a probability paradox. This problem has three solutions because it doesn’t clarify sample space which is intended. So, we modified Bertrand’s chord problem to have the single probability, and we examined how college students studying mathematics and mathematics education seek out the sample spaces represented in five modified Bertrand’s chord questions. Additionally the study highlighted the importance of clarifying the sample space in defining the probability space. From the results of the survey, the following implications for probability education were obtained.

First, in some modified Bertrand’s chord questions (No. 1 & No. 2) in which the sample space is clearly defined, approximately 70% of the surveyed college students correctly determined the sample space and event and calculated its probability. These results imply that many students can get a single probability by clarifying the sample spaces in some questions without any confusion. We suggest that it is necessary to clearly expose the sample space in probability questions unless we does not use Bertrand’s chord problem as an open-ended question that can generate multiple answers with various approaches.

Second, in questions with clearly defined sample spaces (No. 3, No. 4, & No. 5), approximately 80% of the surveyed students failed to determine the sample spaces and events correctly. This means that many students still have difficulty in determining all possible outcomes that could occur in some probabilistic tasks even though they understand the concept of probability. It is in agreement with previous studies which suggested that many students have difficulty in seeking out the sample space (e.g., Borovcnik & Bentz, 1991; Borovcnik, & Kapadia, 2009; Konold, 1989; Speiser & Walter, 1998). Probability causes many controversies every moment when students accept it (Freudenthal, 1973) and students’ probabilistic thinking improves by education (Fischbein, 1975; Fischbein & Schnarch, 1997; Kwon, Kim, & Lee, 2014; Rubel, 2007). With these reports, the result of this study indicates that the importance of the sample space should be highlighted in probability education and that the process of clearly recognizing sample spaces should be introduced. Under the current secondary school curriculum, probability questions are limited only to sample spaces with finite numbers of elements; however, it is necessary to highlight the importance of clearly recognizing sample spaces when teaching the concept of probability. At this stage, it is

recommended to use Simpson's paradox (Borovcnik et al., 1991) when considering sample spaces with finite numbers of elements.

Finally, we are looking forward that this study helps mathematics teachers and students to understand Bertrand's chord problem and its solutions in terms of sample space. In particular, we suggest that the modified question No. 4 and No. 5 may be used to help a deeper understanding of the probability and its sample space because most of students had difficulties to clarify the sample spaces and to calculate probability in these questions. Also we agreed with the conclusion of Aerts and Sassoli de Bianchi (2004) that Bertrand's chord problem is not anymore a paradox.

## REFERENCES

- Aerts, D., & Sassoli de Bianchi, M. (2014). Solving the hard problem of Bertrand's paradox. *Journal of Mathematical Physics*, 55(8), 1-15. <https://doi.org/10.1063/1.4890291>
- Agus, M., Peró-Cebollero, M., Penna, M. P., & Guàrdia-Olmos, J. (2015). Comparing psychology undergraduates' performance in probabilistic reasoning under verbal-numerical and graphical-pictorial problem presentation format: what is the role of individual and contextual dimensions? *Eurasia Journal of Mathematics, Science, & Technology Education*, 11(4), 735-750. <https://doi.org/10.12973/Eurasia.2015.1382a>
- Alexander, R., & Kelly, B. (1999). *Mathematics 12: Western Canadian edition*. Don Mills, Canada: Addison-Wesley.
- Batanero, C., & Borovcnik, M. (2016). *Statistics and probability in high school*. Rotterdam, The Netherlands: Sense Publishers.
- Batanero, C., Henry, M., & Parzys, B. (2005). The nature of chance and probability. In G. A. Jones (Ed.), *Exploring probability in schools: challenges for teaching and learning* (pp. 15-37). New York, NY: Springer.
- Bertrand, J. (1889). *Calcul des probabilités* [Calculation of probability]. Paris, France: Gauthier-Villars.
- Borovcnik, M., & Bentz, H. J. (1991). Sample space and symmetry view. In R. Kapadia & M. Borovcnik (Eds.), *Chance encounter: Probability in education* (pp. 77-82). Dordrecht, The Netherlands: Kluwer.
- Borovcnik, M., & Kapadia, R. (2009). Research and developments in probability education. *International Electronic Journal of Mathematics Education*, 4(3), 111-129. [https://doi.org/10.1007/978-3-319-31625-3\\_1](https://doi.org/10.1007/978-3-319-31625-3_1)
- Borovcnik, M., Bentz, H. J., & Kapadia, R. (1991). A probabilistic perspective. In R. Kapadia & M. Borovcnik (Eds.), *Chance encounter: Probability in education* (pp.50-62), Dordrecht, The Netherlands: Kluwer.
- Chernoff, E. J. (2009). Sample space partitions: An investigative lens. *The Journal of Mathematical Behavior*, 28(1), 19-29. <https://doi.org/10.1016/j.jmathb.2009.03.002>
- Chernoff, E. J., & Zazkis, R. (2011). From personal to conventional probabilities: From sample set to sample space. *Educational Studies in Mathematics*, 77(1), 15-33. <https://doi.org/10.1007/s10649-010-9288-8>
- Choi, J., Yun, Y., & Hwang, H. (2014). A study on pre-service teachers' understanding of random variable. *Journal of Korea Society Educational Studies in Mathematics School Mathematics*, 16(1), 19-37.
- Drory, A. (2015). Failure and uses of Jaynes' principle of transformation groups. *Foundations of Physics*, 45(4), 439-460. <https://doi.org/10.1007/s10701-015-9876-7>
- Fischbein, E. (1975). *The intuitive sources of probabilistic thinking in children*. Dordrecht, The Netherlands: Reidel.
- Fischbein, E., & Gazit, A. (1984). Does the teaching of probability improve probabilistic intuitions? *Educational Studies in Mathematics*, 15(1), 1-24. <https://doi.org/10.1007/BF00380436>
- Fischbein, E., & Schnarch, D. (1997). The evolution with age of probabilistic, intuitively based misconceptions. *Journal for Research in Mathematics Education*, 28(1), 96-105. <https://doi.org/10.2307/749665>
- Freudenthal, H. (1973). *Mathematics as an educational task*, Dordrecht, Holland: Reidel.
- Garfield, J., & Ahlgren, A. (1988). Difficulties in learning basic concepts in probability and statistics: implications for research. *Journal for Research in Mathematics Education*, 19(1), 44-63. <https://doi.org/10.2307/749110>
- Gauvrit, N., & Morsanyi, K. (2014). The equiprobability bias from a mathematical and psychological perspective. *Advances in Cognitive Psychology*, 10(4), 119-130. <https://doi.org/10.5709/acp-0163-9>
- Gillies, D. (2000). *Philosophical theories of probability*. New York, NY: Routledge.
- Green, D. R. (1983). A survey of probability concepts in 3000 pupils aged 11-16 years. In D. R. Grey, P. Holmes, V. Barnett, & G. M. Constable (Eds.), *Proceeding of the first international conference on teaching statistics* (pp. 766-783). Sheffield, UK: Teaching Statistics Trust.
- Gyenis, Z., & Rédei, M. (2015). Defusing Bertrand's paradox. *The British Journal for the Philosophy of Science*, 66(2), 349-373. <https://doi.org/10.1093/bjps/axt036>



- Hawkins, A., & Kapadia, R. (1984). Children's conceptions of probability: a psychological and pedagogical review. *Educational Studies in Mathematics*, 15(4), 349-377. <https://doi.org/10.1007/BF00311112>
- Jaynes, E. T. (1973). The well-posed problem. *Foundations Physics*, 3(4), 477-492. <https://doi.org/10.1007/BF00709116>
- Jones, G. A., Langrall, C. W., & Mooney, E. S. (2007). Research in probability: Responding to classroom realities. In F. K. Lester (Ed.), *Second handbook of research on mathematics teaching and learning* (pp. 909-955). New York, NY: Macmillan.
- Jones, G., Langrall, C. W., Thornton, C., & Mogill, A. (1997). A framework for assessing and nurturing young children's thinking in probability. *Educational Studies in Mathematics*, 32(2), 101-125. <https://doi.org/10.1023/A:1002981520728>
- Jones, G., Langrall, C. W., Thornton, C., & Mogill, A. (1999). Students' probabilistic thinking in instruction. *Journal for Research in Mathematics Education*, 30(5), 487-519. <https://doi.org/10.2307/749771>
- Kim, J. H. (2008). *Probability Theory for insurance mathematics*. Seoul, Korea: Kyo Woo Sa.
- Klyve, D. (2013). In defense of Bertrand: The non-restrictiveness of reasoning by example. *Philosophia Mathematica*, 21(3), 365-370. <https://doi.org/10.1093/philmat/nkt028>
- Konold, C. (1989). Informal conceptions of probability. *Cognition and Instruction*, 6(1), 59-98. [https://doi.org/10.1207/s1532690xci0601\\_3](https://doi.org/10.1207/s1532690xci0601_3)
- Kwon, J. G., & Lee, B. (2015). Probabilistic misconceptions of elementary pre-service teachers. *Advanced Studies in Contemporary Mathematics*, 25(1), 179-188.
- Kwon, J. G., Kim, H. J., & Lee, B. (2014). The differences of probabilistic thinking between ordinary students and students talented in mathematics and science across grade levels. *Proceedings of the Jangjeon Mathematical Society*, 17(2), 259-271.
- Lee, K. H. (1997). A Study on the Probability. *The Science Education Research Collection of Cheongju National University of Education*, 18, 21-35.
- Marinoff, L. (1994). A resolution of Bertrand's paradox. *Philosophy of Science*, 61(1), 1-24. <https://doi.org/10.1086/289777>
- Porto, P. D., Crosignant, B., Ciattoni, A., & Liu, H. C. (2011). Bertrand's paradox: A physical way out along the lines of buffon's needle throwing experiment. *European Journal of Physics*, 32(3), 819-826. <https://doi.org/10.1088/0143-0807/32/3/017>
- Rowbottom, D. P. (2013). Bertrand's paradox revisited: Why Bertrand's solutions' are all inapplicable. *Philosophia Mathematica*, 21(1), 110-114. <https://doi.org/10.1093/phimat/nks028>
- Rubel, L. H. (2007). Middle school and high school students' probabilistic reasoning on coin tasks. *Journal for Research in Mathematics Education*, 38(5), 531-556. <http://www.jstor.org/stable/30034964>
- Shaughnessy, J. M. (1977). Misconceptions of probability: an experiment with a small-group, activity-based, model building approach to introductory probability at the college level. *Educational Studies in Mathematics*, 8(3), 295-316. <https://doi.org/10.1007/BF00385927>
- Shaughnessy, J. M. (1998). Research in probability and statistics. In D. A. Grouws (Ed.), *Handbook of research on mathematics teaching and learning* (pp. 465-494). New York, NY: Macmillan.
- Speiser, B., & Walter, C. (1998). Two dice, two sample spaces. In L. Pereira-Mendoza (Ed.), *Proceedings of the fifth international conference on teaching statistics* (pp. 61-66). Singapore: International Statistical Institute.
- Woo, J. H. (1998). *Educational basis for school mathematics*. Seoul, Korea: Seoul National University Press.



<http://www.ejmste.com>



<https://twitter.com/ejmste>



<https://www.facebook.com/ejmste>



<http://modestum.co.uk/>



[publications@modestum.co.uk](mailto:publications@modestum.co.uk)

## Aims for Learning 21st Century Competencies in National Primary Science Curricula in China and Finland

Yan Wang<sup>1\*</sup>, Jari Lavonen<sup>1,2</sup>, Kirsi Tirri<sup>3</sup>

<sup>1</sup> Faculty of Educational Sciences, University of Helsinki, Helsinki, FINLAND

<sup>2</sup> Department of Childhood Education, University of Johannesburg, Soweto, SOUTH AFRICA

<sup>3</sup> Helsinki Collegium for Advanced Studies, University of Helsinki, Helsinki, FINLAND

Received 30 October 2017 • Revised 25 January 2018 • Accepted 9 February 2018

### ABSTRACT

Incorporation of aims for learning 21st century competencies in subject-specific curricula and education has been an important issue worldwide. This study explored the integration of aims for learning such competencies into the National Primary Science Curricula in China and Finland. Both Curricula showed an emphasis on aims related to science education, such as inquiry and information literacy. Yet the density of appearance of competencies for the 21st century in the Chinese Curriculum is lower than in the Finnish Curriculum. Additionally, the Chinese Curriculum illustrates the shortage of aims in the Living in the World category. The significant differences between the Curricula have to do with the educational theories underpinning each national curriculum. The Chinese Curriculum has a tendency to align with the Anglo-American curriculum tradition, whereas the Finnish Curriculum is more closely aligned with the German *Bildung-Didaktik* tradition. A national curriculum in different subject areas could be designed whose central purpose would be cultivating holistic individuals and targeting goals for disciplinary knowledge and skills. Merits of the different educational traditions need to be examined and considered in the curriculum design process.

**Keywords:** 21<sup>st</sup> century, competency, science curriculum, Finland, China

### INTRODUCTION

The purpose of this article is to investigate how aims for learning 21st century competencies are incorporated into the Chinese and the Finnish National Primary Science Curricula. We also wish to identify and explain similarities and differences between the two science Curricula in terms of the elements of these competencies from the perspective of the different educational traditions that underpin the curriculum documents.

### Goals for Teaching and Learning 21st Century Competencies Worldwide

Reforming education for 21st century needs has been an important topic of discussion worldwide (European Union, 2008; Finnish National Board of Education, 2016; National Research Council, 2012; Voogt & Roblin, 2012). International organizations, such as the European Union, have declared education to be the means by which we ensure that citizens acquire the key competencies needed to live in our changing world (European Union, 2008; Voogt & Roblin, 2012). The term *21st century competencies* refers to redefining the aims for education or learning outcomes according to the capabilities needed in the 21st century (Binkley, Erstad, Herman, Raizen, Ripley, Miller-Ricci & Rumble, 2012; Trilling & Fadel, 2009). Even though different terminologies are used to describe 21<sup>st</sup> century competencies (for example, key competencies or competences, generic competencies, transversal competences, interdisciplinary skills), all have similar connotations and compositions (Wang, Lavonen & Tirri, in press). The need for holistic education in the 21<sup>st</sup> century, not only naturalizing the cognitive domain, but also promoting values

#### Contribution of this paper to the literature

- In general, most of the 21st century competencies listed in the framework have been integrated into the Curriculum in both countries.
- Both the Chinese and the Finnish Science Curricula show an emphasis on aims for science-related competencies, information literacy and inquiry.
- The Chinese Science Curriculum illustrates a significant deficiency in integrating competencies related to aims for moral and rational individual living.

and worldviews along with a growth mindset for learning and ethical skills has been discussed (Ornstein & Hunkins, 2013; Tirri, 2016). In the present research 21<sup>st</sup> century competencies are defined as an integration of the knowledge, skills, attitudes, and values that all young people of our time are required to have (Ananiadou & Claro, 2009; European Union, 2008; National Research Council, 2012; Voogt & Roblin, 2012).

### Changes in the Chinese and the Finnish Curricula Echo Recent International Changes

With the emergence of educational goals for 21st century competencies, countries around the world have developed their own frameworks for teaching these skills, including China and Finland. In June of 2016, China published the latest version of its document “Core Competencies for Student Development” after four years of research and discussion among researchers, educators, policymakers and teachers. The essence of the document is to cultivate the individual as a whole by emphasising “core competencies” in the following areas: 1) learning to learn, 2) living in a healthy way, 3) taking responsibility as a citizen, 4) practice, creativity and innovation, 5) knowledge of one’s cultural heritage, and 6) scientific literacy. In Finland seven areas of core competencies (called “transversal competences” in the Finnish National Core Curriculum 2014) have been proposed, including 1) thinking and learning to learn, 2) cultural competence, interaction, and self-expression, 3) taking care of oneself, managing daily life, 4) multi-literacy (“Multi-literacy is the competence to interpret, produce and make a value judgement across a variety of different texts, which will help the pupils to understand diverse modes of cultural communication and to build their personal identity”), 5) competence in information and communication technology, 6) working-life competence and entrepreneurship, and 7) participation, involvement and building a sustainable future (Finnish National Board of Education, 2016).

The questions of how to integrate 21st century competencies into a national curriculum and into school subjects and how to teach these competencies through learning activities are some of the most important challenges in education today (Benade, 2014; Burden & Hall, 2005; National Research Council, 2012; Finnish National Board of Education, 2016; Reimers & Chung, 2016). The Chinese national curriculum is revised about every ten years, as is the Finnish national curriculum. The previous Chinese National Curriculum (an experimental version) was published in 2001 and revised in 2011. Since 2016, a new round of revisions has been in progress whose purpose is to integrate the newly published core competencies into different subjects. Curricula for different subjects at each level have been officially published one by one. However, the new National Primary Science Curriculum officially published in 2017 has not yet been written with the intention of integrating 21<sup>st</sup> century competencies.

By contrast, the seven areas of transversal competences in the Finnish National Core Curriculum for Basic Education 2014 were integrated into every level of education and into every subject, including science at the primary school level (Finnish National Board of Education, 2016; Vahtivuori-Hänninen et al., 2014). Moreover, the momentum for cultivating generic competencies in the Finnish curriculum began gathering steam in the 1970s. Objectives such as cross-curricular themes of “cultural identity and internationality” and “well-being and sustainable future” were proposed and integrated into different subjects in the Finnish National Core Curriculum in 2004 (Autio, Kaivola & Lavonen, 2007). However, Finland faces challenges in fulfilling the aims for 21<sup>st</sup> century competencies in reality.

### Curriculum Stability and Changes in China and Finland

A national curriculum is a plan of study outlining the goals for education at a national level, and as such, it guides and regulates the instructional processes throughout a country (Oliva, 1997; Ornstein & Hunkins, 2013). A national curriculum includes subject matters, skills and values that policymakers expect students to learn (Cuban, 1992). It is not a neutral document; rather, “it is produced out of the cultural, political, and economic conflicts, tensions and compromises” (Apple, 1993, p. 1) of a given country and reflects national values (van den Akker, 2003). Although the national curriculum changes with a society’s changing demands and the development of psychological and educational theories, the constancy of culture, values and theories, and traditions of schooling, teaching and learning are deeply embedded in a country’s curriculum (Cuban, 1992).

The European-Scandinavian *Bildung-Didaktik* and the Anglo-American curriculum are two major curriculum theories and practices embedded in western countries (Autio, 2014; Westbury, 2000). American curriculum theory today and *Didaktik* are not far apart from the perspective of the present, because they are concerned with similar issues in education, for instance, teaching and learning goals. They have also developed dynamically through increasing interaction and globalized influences. In this research, *Bildung-Didaktik* and the Anglo-American curriculum refer to a traditional perspective, and the arguments are built on their differences. Nevertheless, this research does not aim to dichotomize the two traditions. To be specific, these two traditions are fundamentally different in their aims for teaching and learning, in the functions of a national curriculum within the institutional systems and in the roles of individual teachers (Pantić & Wubbels, 2012; Westbury, 2000). The *Bildung-Didaktik* tradition aims at cultivating individuals to be competent to live successfully and participate in society and, ideally, to reconstruct the society (Autio, 2014). It is a tradition that highlights the discourse or conversations between the teacher and students about the subject matter in each lesson and shows respect for teachers' academic freedom and autonomy (Autio, 2014; Hopmann, 2007; Saari, Salmela & Vilkkilä, 2014; Sahlberg, 2015; Westbury, 2000). Thus, although there is a *Lehrplan* (literally, a teaching plan) in the *Bildung-Didaktik* tradition, such a plan could only be meaningful and educative when implemented by well-trained teachers (Autio, 2014; Hopmann, 2007; Pantić & Wubbels, 2012; Westbury, 2000). Teachers are considered to be professional experts with complete freedom within the framework of an illustrated *Lehrplan* and are not assessed solely on the basis of students' learning outcomes (Westbury, 2000). By contrast, the development of the Anglo-American curriculum has been based on Tyler's Rationale and theories of psychology, which involve standardization and accountability in the educational system. Educational practices developed from this tradition focus on "transmission of knowledge" from society to learners, rather than on educating the whole person (Pantić & Wubbels, 2012; Westbury, 2000). The curriculum and the teaching plans are well-articulated in this tradition, and the educational goals in schools are meant to achieve the stated objectives and the illustrated contents. The teachers are considered passive agents of the system: they can be trained and certified, and they are assessed by the students' learning outcomes (Autio, 2014; Westbury, 2000). Their responsibilities are to follow and implement the requirements of the national curriculum.

The Finnish curriculum developed as a hybrid of the *Bildung-Didaktik* and Anglo-American curriculum traditions (Autio, 2014; Hopmann, 2007; Saari, Salmela & Vilkkilä, 2014; Sahlberg, 2015). *Bildung*, which means educating the whole person, is a fundamental premise of Finnish education, although after the Second World War the Finnish curriculum was influenced by the Anglo-American curriculum tradition and psychology theories from the United States (Autio, 2014; Lampiselkä, Ahtee, Pehkonen, Meri & Eloranta, 2007; Saari et al., 2014). The Finnish tradition highlights the individual's subjectivity as well as intersubjectivity, which considers both the rights and duties of citizens. Citizenship has been considered as part of the school curriculum in Finland, thanks to the distinguished statesman and philosopher Johan Vilhelm Snellman (Saari et al., 2014). Since the curriculum reforms in the 1990s, Finland's national school administration has been transformed from a centrally governed system to a decentralized system, and Finnish teachers have been given more and more autonomy (Lampiselkä et al., 2007). The national curriculum turns out to be a guideline for teaching instead of a complete set of requirements with goals and prepared materials. The teachers themselves participate in the development of national, local and school curricula. They can choose content and textbooks and can organize classes as they want.

The development of the Chinese curriculum has taken cues from America, the Soviet Union and other foreign countries, such as Japan (Zhang & Gao, 2014). Curriculum theory in China has been affiliated with the two western theories mentioned above and developed into a new pedagogical field called "Curriculum and Didactics" (Ding & Wang, 2013). Since the 1990s, the Chinese curriculum has been significantly affected by the Anglo-American curriculum, for instance in its standards of science (Ding, 2015), which like the American curriculum explain the aims of science education in detail. However, since the curriculum reforms in the early 2000s, studies of Chinese curriculum theory have pointed up the merits of Chinese traditional educational theories, including ideas from Confucianism, Taoism, and Buddhism, and the value of combining these with experiences and theories learned from western and other Asian countries (Autio, 2014; Pinar, 2014; Zhang & Gao, 2014). Similar to the concept of *Bildung*, Chinese education has a tradition of targeting the development of the whole person based on Chinese traditional wisdom, including Confucianism, Buddhism and Taoism. For example, from the perspective of Confucianism, the ultimate aim of education should be to cultivate a human being's virtue. Although the Chinese have been trying to change from a centralized to a decentralized educational system that gives teachers more autonomy, the national curriculum still plays a main part in curriculum implementation. Teachers follow the national curriculum faithfully step by step. For example, primary school science teachers struggle to follow the well-organized but large amount of content called for by the national curriculum within the prescribed, limited number of weekly lessons (Zhong & Gao, 2007). This means that in reality teachers seldom have the freedom they are encouraged to have.

## Science Education in China and Finland

Science education is an unavoidable part of modern education (Millar, 2006). The Finnish Science Curriculum is part of the Core Curriculum, which includes all subjects at different levels. By contrast, the Chinese National Primary Science Curriculum (referred to below simply as “Finnish/ Chinese Curriculum”) is an independent document. In both China and Finland, “science” is taught in primary schools as an integrated subject that includes different topics, such as physics, chemistry and biology. However, topic coverage differs in each country. The Chinese Curriculum includes physics, chemistry, biology and geography, as well as technology and engineering. The Finnish Curriculum includes biology, geography, physics, chemistry, health education and, not least, technology as integrated topics. In the Chinese context geography means natural geography only, whereas in the Finnish context, it includes human or cultural geography as well as natural geography.

In Finland, all the subjects are seen as equal and all are important, because the education aims at the development of the whole individual (Lavonen & Laaksonen, 2009; Sahlberg, 2015). In Finnish primary schools, science is called environmental studies and is taught by a class teacher in two lessons (45 minutes per lesson) a week in Grades 1-2, and on average in 2.5 lessons a week in Grades 3-6. By contrast, Chinese primary science education is peripheral in comparison to the Chinese languages and mathematics, taught by a subject teacher in science. Two lessons per week (45 minutes per lesson) are required in Grades 3-6. However, in reality, schools often lack the time to arrange a sufficient number of courses. The status of science education at the primary level has been changing in Chinese schools. Beginning in the autumn of 2018, primary science education will be compulsory from Grade 1 to Grade 6, parallel with the implementation of the new National Primary Science Curriculum.

### Significance of the Research and the Research Questions

Comparing the curricula in China and Finland is worthwhile. Comparative research can help identify similarities and differences and may even reveal the “power” system and system of ideas (Goedegebuure & Van Vught, 1996; Tröhler, 2013). The two countries are based on different educational cultures, yet perform similarly in international assessments. Both have exhibited high levels of performance followed by a decline in international assessments with educational reforms (for example, the OECD Programme for International Student Assessment or PISA; see OECD, 2014; OECD, 2016). Disciplinary knowledge in science has been regarded as a powerful source of intellectual and moral capabilities, which could fulfil the task for teaching and learning 21<sup>st</sup> century competencies (Aktamis & Ergin, 2008; Boh Podgornik, Dolničar, & Glažar, 2017; Deng, 2015; Kind & Kind, 2007). Hence, research on science curricula has significance.

In the current paper, we address the following research questions:

1. How are 21<sup>st</sup> century competencies described in the Chinese and the Finnish National Primary Science Curricula?
2. What are the similarities and what are the differences in the elements of 21<sup>st</sup> century competencies in the Primary Science Curricula of China and Finland?
3. How can we explain the similarities and differences in the integration of 21<sup>st</sup> century competencies found in the two Curricula?

### ANALYTICAL FRAMEWORK

The analytical framework used in this research was developed in a pilot project that compared frameworks of 21<sup>st</sup> century competencies (Wang et al., in press). The framework has been revised by purposefully considering the intersection between the cultivation of generic competencies and science education.

Twelve competencies were identified, which were grouped into four categories that follow the Assessment and Teaching of 21<sup>st</sup> Century Skills (ATC21S) framework (Binkley et al., 2012); these are called Ways of Thinking, Ways of Working, Tools for Working and Living in the World (see [Table 1](#)). *Ways of Thinking* includes competencies focused on the cognitive domain (Cropley, 2011; Fisher, 1991; Hoskins & Fredriksson, 2008; Mason, 2007; Villalba, 2011). *Ways of Working* consists of competencies needed to carry out a project, including cognitive-based manners (Inquiry and Problem solving) and social-based manners (Communication and Collaboration) (Anderson, 2007; John-Steiner, 2011; Merriam-Webster online Dictionary; Ward, 2011). “Inquiry” and “Problem solving” were specifically revised in this research by considering their close relationship to science education (Abd-El-Khalick et al., 2004; Eylon & Linn, 1988). The category *Tools for Working* includes the competencies in comprehending or using “tools”. Since “Information literacy” is the ability to recognize, locate and use information (concepts) needed for a certain context efficiently and effectively (Eisenberg, Lowe, & Spitzer, 2004), it can be seen as a “tool” in science-related issues. *Living in the World* includes the competencies to negotiate the changing world with respect to life, social and cultural responsibilities.



**Table 1.** Analytical Framework for 21st Century Competencies

Category	Subcategory	Operational definition	Example
Ways of Thinking	Creative thinking	Imaginative (thinking from various novel aspects), inventive competency, which involves the generation of new ideas (connecting and summarizing information or ideas in novel ways) (Fisher, 1991) and the production of relevant and effective novelty (Cropley, 2011).	[The curriculum is designed to] cultivate students' awareness of innovation, awareness of environmental protection and social responsibility, and learning to cooperate with others.
	Critical thinking	Involves the evaluation, analysis, synthesis and interpretation of something to provide a judgement or promotes thinking or valuing ideas, facts and methods from different perspectives, usually from an opposite perspective (Mason, 2007; Villalba, 2011).	Cultivate critical thinking skills.
	Using metacognition (Learning to learn)	Using metacognition refers to the ability to pursue and persist in learning, to organize one's own learning, reflecting on the learning, and adjusting the learning process, including through effective management of time and information, both individually and in groups (Hoskins & Fredriksson, 2008). Learning to learn refers to the competency for lifelong learning. (In this research, the main characteristic of the metacognition competency is seen as the manifestation of the Learning to learn competency.)	Makes students learn to regulate study by themselves and study individually.
Ways of Working	Inquiry	Refers to a systematic action process in investigating, collecting, and examining issues in a situation. In a science inquiry (science practice), it means that one is asking questions, planning and carrying out investigations; analysing and interpreting data; and developing explanations (Anderson, 2007).	The multidisciplinary nature of environmental studies requires students to learn to acquire, process, produce, present, evaluate, and appraise information in different situations.
	Problem-solving	Refers to a systematic process whereby the person overcomes obstacles and moves from a beginning state to a goal state (Ward, 2011). The problem can be science- or technology-related knowledge or life-situation related.	To make students learn to solve practical problems in life.
	Collaboration	A competency in studying or working with one or more individuals in groups, where participants help and support each other with complementary skills, interacting to create a shared understanding that none had previously possessed or could have come to on their own (John-Steiner, 2011).	Learning to co-operate with others
	Communication	The competency of using words, sounds, signs, or other behaviours to express or exchange information, such as ideas, thoughts and feelings, to someone else with respect or listening to other people (Merriam-Webster online Dictionary).	Students should learn to present the inquiry process and results and to discuss and communicate these with classmates.
Tools for Working	Information literacy	The ability to recognize and comprehend scientific concept, then locate, and use information (concepts) needed for a certain context efficiently and effectively, for example, to explain phenomena using scientific concepts (Eisenberg, Lowe & Spitzer, 2004).	In chemistry, it is central to explain their properties, structures and changes that take place in them.
	ICT literacy	Refers to the ability to recognize, locate and use information needed for a certain context efficiently and effectively via information and communication technology.	To instruct the pupil to use information and communication technology responsibly, safely and ergonomically for acquiring, processing and presenting information and as a means of interaction.
Living in the World	Citizenship	Refers to competency in participating in civic activities/ in society-related activities. It includes, but is not limited to environmentally-friendly activities, the economy or society development activities, energy-saving activities.	Improve the [students'] ability to facilitate the development of society and the economy.
	Life and career	A set of different competencies in understanding unstable situations, settling the challenges in a changeable world with intentions for a good, rational and moral life.	Promote the development of competence that supports health, well-being and safety.
	Personal and Social responsibility (cultural awareness and competence)	Refers to competency in tolerance and respect for people different from themselves and of other backgrounds, for example, in race, ethnicity, lifestyles. It includes cultural and global awareness and sensitivity and personal identification (Musil, 2009). It manifests in aspects of culture, humanity, and morality in science education.	The pupils practise their emotional skills and promote mental well-being, such as respecting themselves and others according to their age.

## METHODS

The study went through the stages of defining categories and coding rules, a pilot test, a revision of the coding guidelines and a final coding of the text. The deductive content analysis process followed the examples of Weber (1990), Mayring (2015) and Schwarz (2015). The framework above offers an objective and neutral perspective for comparing the two Curricula. The coding examples and the approach to coding are shown below (for more examples, see **Table 1**). Each coding unit includes one idea. To increase validity and reliability, three authors

worked together and were involved in the pilot analysis. The first author is a doctoral student in Finland who is familiar with Chinese education and the Chinese curriculum and is doing research on science education and curriculum studies. The second author is a professor of science education and has 25 years of experience in science education research. He has participated in preparing the Finnish national level curriculum since the 1990s and has written several papers, supervised PhD theses and examined theses in curriculum research. Moreover, he has evaluated several foreign curricula in science and teacher education. The third author is a Finnish full professor in education who has done comparative research in teaching and learning for 25 years and whose expertise is comparing the educational aims of diverse countries. The first author translated the Chinese Curriculum into English. The first two authors then carried out a pilot analysis. Based on the pilot coding, the three authors further discussed and revised the categories and coding rules. Half the Finnish Curriculum was analysed independently by the first two authors. The agreement was 0.5. Then the description of categories was further clarified, and the units difficult to code were discussed by the three analysts. After the revision Cohen's kappa representing inter-rater agreement reached 0.87; as 0.81-0.89 is an almost perfect agreement (Viera & Garrett, 2005), the number demonstrates the reliability of the analysis.

Examples from the Chinese Curriculum:

[The curriculum is designed to] cultivate students' awareness of innovation, awareness of environmental protection and social responsibility, and learn to co-operate with others. (Chinese Curriculum, p. 2)

- Creative thinking (*"Innovation" connects with the creative ideas and awareness, demonstrating the competency of creative thinking.*)
- Citizenship (*Both "environmental protection" and "social responsibility" demonstrate the requirements for competency of living as a responsible citizen.*)
- Collaboration (*"Co-operation with others" demonstrates working together with others or peers, belonging to the competency of collaboration.*)

Examples from the Finnish Curriculum:

The multidisciplinary nature of environmental studies requires [students] to learn to acquire, process, produce, present, evaluate, and appraise information in different situations (Finnish Curriculum, p. 5).

- Inquiry (*"Acquire", "process", "produce", "observe", or "conduct research" demonstrate the competency of inquiry*)
- Communication (*To "present" or "discuss" demonstrates the competency of communication*)

In chemistry, it is central to: ... explain [different substances'] properties, structures, and changes that take place (Finnish Curriculum, p. 1).

- Information literacy (*"Explain" is based on the usage of concepts, demonstrating the competency of information literacy*)

In health education, it is essential to understand factors in the environment and in human activities that support and protect health and promote the competence that supports health, well-being and safety (Finnish Curriculum, p. 1).

- Life and career (*Usually, "well-being" demonstrates the competency of life and career. Well-being means competency for living in a wellness way in a changeable world.*)

After the coding process, we calculated the observed frequencies and percentages for each category and subcategory to demonstrate how often the competencies appeared. The distributions between subcategory frequencies in the Chinese and Finnish Curricula were compared, using a Chi-Square Test ( $\chi^2$ ), which tests the hypothesis that the row and column variables are independent without indicating strength or direction of the relationship. The Chi-Square Test was done via an online tool (Preacher, 2001). The direct quotations from both curricula were shown to demonstrate how the aims of learning the competencies are presented similarly or differently in aspects of content (whether the description of a specific competency belongs to a similar area) or mode of description (what specific words used or from whose/ which viewpoint the aims for a specific competency were described).

## RESULTS

### Distribution of the Competencies as a Whole in the Two Curricula

Based on the total number, the Chinese Curriculum included more units of 21st century competencies (N=397) than the Finnish Curriculum (N=295). However, the length of the Finnish Curriculum text (9 pages, 3,942 words analysed) is much shorter than the Chinese (38 pages, 25,692 words analysed), which demonstrates that the density of appearance of 21st century competencies is higher in the Finnish Curriculum than in the Chinese.

**Table 2.** Frequencies and percentages of different 21<sup>st</sup> century competencies

Categories/ Subcategories	China	Ranking	Finland	Ranking
<i>Ways of Thinking</i>	61 (15.4%)		41 (13.9%)	
Critical thinking	20 (5.0%)	6	11 (3.7%)	8
Creative thinking	15 (3.8%)	8	10 (3.4%)	10
Using metacognition (Learning to learn)	26 (6.6%)	4	20 (6.8%)	5
<i>Ways of Working</i>	155 (39.0%)		116 (39.3%)	
Inquiry	102 (25.7%)	2	82 (27.8%)	1
Problem solving	23 (5.8%)	5	6 (2.0%)	12
Collaboration	11 (2.8%)	9	17 (5.8%)	6
Communication	19 (4.8%)	7	11 (3.7%)	8
<i>Tools for Working</i>	151 (38.0%)		59 (20.0%)	
ICT	1 (0.2%)	10	7 (2.4%)	11
Information literacy	150 (37.8%)	1	52 (17.6%)	2
<i>Living in the World</i>	30 (7.6%)		79 (26.8%)	
Citizenship	29 (7.3%)	3	36 (12.2%)	3
Life and career	0 (0.0%)	12	27 (9.2%)	4
Personal and social responsibility	1 (0.2%)	10	16 (5.4%)	7
Total	397		295	

$\chi^2=58.1$ ,  $p<0.05$  (according to the distribution of frequencies in each category)

The frequency distributions of 21<sup>st</sup> century competencies are, in general, significantly different in the two primary science Curricula ( $\chi^2=58.1$ ,  $p<0.05$ ; see **Table 2**). In the Chinese Curriculum, the frequencies and distribution of the competencies/subcategories are from 0 (Life and Career, 0%) to 150 (Information Literacy, 37.8%); the distribution of the main categories is from 7.6% (Living in the World) to about 39% (Ways of Working and Tools for Working) (see **Table 2**). It demonstrates a large gap between the categories, especially a minor emphasis on Living in the World category. In the Finnish Curriculum, the frequencies and distribution of the competencies are from 6 (Problem Solving, 2%) to 82 (Inquiry, 27.8%); the distribution of the main categories is from 13.9% (Ways of Thinking) to 39.3% (Ways of Working), the Tools for Working (20%) and Living in the World (26.8%) categories are compositions with numbers in the middle. As a whole, the spread of the distribution in the Finnish Curriculum is not as large as in the Chinese Curriculum.

The Curricula in both countries emphasized learning the competencies needed in inquiry-orientated work and information literacy. Ways of Thinking and Ways of Working are the two categories similarly weighted in both. The most emphasized feature was “Inquiry” in Ways of Working. The difference in emphasis is most strikingly manifested in the categories Tools for Working and Living in the World. “Information literacy” takes up the largest share of the Tools for Working category, which demonstrates that learning concepts are highly valued in Chinese science education. In the Finnish Curriculum, Tools for Working ranks third and has a significantly lower percentage (20%) than in the Chinese Curriculum (38%).

### Similarities and Differences in Competencies in the Ways of Thinking Category

The distribution of frequencies in the Ways of Thinking subcategories in the two countries is not significant ( $\chi^2=0.49$ ,  $p=0.78$ ; see **Table 3**). “Using metacognition (Learning to learn)” is the most highly emphasized competency in both Curricula (42.6% in the Chinese Curriculum, 48.8% in the Finnish Curriculum). There are both similarities and differences in the descriptions of using metacognition in the two Curricula. Both described using metacognition from a general perspective as well as from a subject-based perspective. In the general perspective, using metacognition is described as “lifelong learning” in the Chinese Curriculum and “sustainable development” or “sustainable future” in the Finnish Curriculum. Persistence in working is mentioned as a “Using metacognition” subcategory in both Curricula. In the subject-based perspective, learning to make plans and reflect on one’s own research are highlighted in both Curricula. For example, “[teachers should] guide and encourage the pupil to set personal study goals and make persistent efforts to achieve them and recognize his or her own competence in environmental studies” (Finnish Curriculum, p. 6); “The students should learn to reflect on their own inquiry process, methods, and results, as well as make self-evaluation and revise the research plan” (Chinese Curriculum, p. 7).

**Table 3.** Distribution of subcategories in Ways of Thinking

Subcategory	China	Finland
Critical thinking	20 (32.8%)	11 (26.8%)
Creative thinking	15 (24.6%)	10 (24.4%)
Using metacognition (Learning to learn)	26 (42.6%)	20 (48.8%)

$\chi^2=0.49$ ,  $p=0.78$

**Table 4.** Distribution of subcategories in Ways of Working

Subcategory	China	Finland
Inquiry	102 (65.8%)	82 (70.7%)
Problem solving	23 (14.8%)	6 (5.2%)
Collaboration	11 (7.1%)	17 (14.7%)
Communication	19 (12.3%)	11 (9.5%)

$\chi^2=10.2$ ,  $p<0.05$

Critical thinking is highlighted almost equally in each Curriculum (32.8% in the Chinese and 26.8% in the Finnish; see [Table 3](#)). Critical thinking is typically mentioned in science contexts in both Curricula. Students are encouraged to ask questions and to think deeply, based on activities or assignments related to the science context. For example, in the Finnish Curriculum, “[Teachers] encourage the pupil to wonder, ask questions, and use collaborative discussions as the basis for small research assignments and other activities” (p. 2); in the Chinese Curriculum, “in studying science, students learn to be critical and ask questions...” (p. 8).

Creative thinking is referred to with the words “creativity” and “innovation” and has a percentage of around 24% in both science Curricula (see [Table 3](#)). Creative thinking is illustrated as encouraging students to think from different perspectives or to find different ways to solve a problem. “Creative”, “different” and their derivatives are the typical keywords used to describe this competency. For example, “[Teachers] inspire pupils to experiment, invent, and be creative together” (Finnish Curriculum, p. 6); “[Students] experiment and find different alternatives and solutions to everyday problems” (Finnish Curriculum, p. 3); “[Students] try to use different materials, strategies, methods in conducting scientific inquiry and experience the joy of creativity and innovation” (Chinese Curriculum, p.8). Both Curricula encourage students to transform their creative ideas into innovations that will connect science with technology or handiwork. For example, “[Students] try to make models or real objects based on their creative ideas” (Chinese Curriculum, p. 38); “[Teachers need] to inspire the pupils to experiment, invent, build, and innovate together with other pupils” (Finnish Curriculum, p. 2).

### Similarities and Differences in Competencies in the Ways of Working Category

The distribution of frequencies in the Ways of Working subcategories is significantly different in the two countries ( $\chi^2=10.2$ ,  $p<0.05$ ). In both Curricula inquiry is the most highly emphasized competency in this category, and is well integrated into the science contexts (see [Table 4](#)). During the coding process, Inquiry is closely related to scientific literacy, such as the ability to explore or observe (Anderson, 2007). For example, “Pupils observe motion and consider the reasons for changes in motion” (Finnish Curriculum, p. 3). Some examples illustrating the different descriptions in the Chinese and Finnish Curricula involve the notion of “scientific inquiry”. In the Chinese Curriculum, “scientific inquiry” as a word appears 26 times, whereas at no time is “scientific inquiry” mentioned in the Finnish Curriculum, although “inquiry-based” is mentioned twice. For example, “Differentiation to meet individual needs may be supported by an inquiry-based working method and exercises completed at various levels of thinking skills” (Finnish Curriculum, p. 9). Although the Chinese Curriculum describes the goals of inquiry as including such competencies as observation – for example, “students learn to observe and compare phenomena and objectives, and propose scientific questions in which they are interested (p. 7)” – it also mentions inquiry as a general word. However, the Finnish Curriculum presents the goals with specific verbs belonging to inquiry; for example, “the pupils observe motion and consider the reasons for changes in motion” (p. 3).

Problem solving ranks as the second highest subcategory in the Chinese Curriculum (N=23, 14.8%), but it is the lowest subcategory in the Finnish Curriculum (N=6, 5.2%; see [Table 4](#)). In the Chinese Curriculum, Problem solving is not only described as a general concept, but also is integrated into content in the area of technology and engineering. For example, “Students can use a lever, pulley, slope, axle, or other simple machines to solve practical problems in daily life” (Chinese Curriculum, p. 37). However, in the Finnish Curriculum, Problem solving appears only as a general concept. For example, “[Students] experiment and find different alternatives and solutions to everyday problems” (Finnish Curriculum, p. 3).

The Chinese and Finnish Curricula show different emphases on the competencies of collaboration and communication. The Chinese Curriculum places more emphasis on communication (N=19, 12.3% in Communication, N=11, 7.1% in Collaboration; see [Table 4](#)). By contrast, the Finnish Curriculum places more

**Table 5.** Distribution of subcategories in Tools for Working

Subcategory	China	Finland
ICT	1 (0.7%)	7 (11.9%)
Information literacy (concepts)	150 (99.3%)	52 (88.1%)

$\chi^2=14.5, p<0.05$

emphasis on collaboration (N=17, 14.7% in Collaboration, N=11, 9.5% in Communication). But the total frequency of Communication and Collaboration mentioned in both Curricula is much lower than the total number of times Inquiry and Problem solving are mentioned. Both Curricula describe collaboration and communication from the perspectives of general competency and science-based content. Communication and collaboration are integrated as competencies in presenting the results of scientific research or as a process of doing research as part of a team. From this perspective, both Curricula present the goals similarly; for example, “Students should learn to present the inquiry process and results, and discuss and communicate these with classmates” (Chinese Curriculum, p. 7); “To guide the pupil to recognize causal relationships, draw conclusions from his or her results, and present the results and research in different ways” (Finnish Curriculum, p. 6). By comparison, the Finnish Curriculum also presents a different view of communication and collaboration. In describing collaboration, the Finnish Curriculum refers to “community” and “well-being”, thereby demonstrating sustainable expectations of students and of society; for example, “Working as a community supports learning together and drawing on different strengths” (Finnish Curriculum, p. 4). In describing communication, the Finnish Curriculum lists goals for cultivating the whole person; for example, “to inspire the pupil to express himself or herself and listen to others as well as to support the pupil in recognizing, expressing, and regulating his or her emotions” (Finnish Curriculum, p. 6). This describes the goals for encouraging students to express not only their views, but also their emotions and attitudes. However, the Chinese Curriculum encourages the expression of views or ideas only, although both Curricula are pedagogically student-centred.

### Similarities and Differences in Competencies in the Tools for Working Category

The Chi-Square tests for differences in distribution in the Tools for Working category are significantly different in the Finnish and Chinese Curricula ( $\chi^2=14.5, p<0.05$ ). Compared to the frequencies of Information literacy, ICT is seldom mentioned in either Curriculum (see [Table 5](#)).

In the Chinese Curriculum, ICT was mentioned once as a tool with which students could present what they had learned. “Students learn to present their ideas via language or digital images, such as photos, videos, pictures...” (Chinese Curriculum, p. 38). ICT was described in three ways in the Finnish Curriculum. One is the same as in the Chinese Curriculum, namely to present the results of student learning in different ways, for example, “guide the pupil to recognise causal relationships, to draw conclusions from his or her results, and to present the results and research in different ways” (Finnish Curriculum, p. 6). Elsewhere, ICT is described as a learning environment, as in this example: “In addition to school facilities and the teaching group, the learning environments include a versatile range of local natural and built environments, various communities and interaction situations, ICT environments as well as local opportunities, including cooperation with ‘nature schools’, museums, companies, non-governmental organizations, and nature and science centres” (Finnish Curriculum, p. 8). The third mention points directly to the goals and ethics of using ICT: “to instruct the pupil to use information and communication technology responsibly, safely, and ergonomically for acquiring, processing, and presenting information and as a means of interaction” (Finnish Curriculum, p. 6).

Verbs such as “describe” and “explain” are identified as symbols of Information literacy. For example, “describe the property of some material, such as magnetism and transparency...” (Chinese Curriculum, p. 11). In only one instance are the information literacy competencies apparently not closely related to a specific science content in the Chinese Curriculum: “Stress learning by doing and cultivate students’ ability in collecting and processing information about science” (Chinese Curriculum, p. 6). One example from the Finnish Curriculum is the following:

*[Teachers should] guide the pupil in perceiving the environment, human activities, and related phenomena using the concepts of environmental studies and developing his or her conceptual structures from preconceptions toward accurate use of concepts (Finnish Curriculum, p. 7).*

### Similarities and Differences in Competencies in the Living in the World Category

Based on the total frequencies, the Finnish Curriculum (N=79) places a much higher value on Living in the World than the Chinese Curriculum (N=30). The Chi-Square tests comparing distribution differences in these subcategories are significant ( $\chi^2=23.8, p<0.05$ ). In the Chinese Curriculum, Citizenship is the most heavily weighted factor (N=29, 96.7%), while Life and career (N=0, 0%) and Personal and social responsibility (N=1, 3.3%) appear only rarely. In the Finnish Curriculum, the Citizenship subcategory is also the most highly ranked (N=36, 45.6%).



**Table 6.** Distribution of subcategories in Living in the World

Subcategory	China	Finland
Citizenship	29 (96.7%)	36 (45.6%)
Life and career	0 (0.0%)	27 (34.2%)
Personal and social responsibility	1 (3.3%)	16 (20.2%)

$\chi^2=23.8$ ,  $p<0.05$

Yet the apparent frequency of Citizenship, life and career (N=27, 34.2%), and Personal and social responsibility (N=16, 20.2%) varies less than in the Chinese Curriculum (see [Table 6](#)).

Citizenship as described in the science curriculum can be grouped in one of two categories: one is general, while the other is related to environmental issues. Both categories appear in both the Chinese and Finnish Curricula. Citizenship means knowledge, skills and attitudes open to participating in civic-related activities (van den Akker, 2003). From the perspective of the general category, the Chinese Curriculum typically describes citizens as being responsible for “society”; for example, “Improve the [students’] ability to facilitate the development of society and the economy” (Chinese Curriculum, p. 2), whereas the Finnish Curriculum normally holds citizens responsible for “community”; for example, “[The students] participate in improving the state of their surroundings and in promoting the well-being of the school community” (Finnish Curriculum, p. 4). From the perspective of environmental issues, one description in the Chinese Curriculum specifically connects citizenship with environmental issues: “[Students] should be aware of their responsibility in protecting the environment and saving resources” (p. 9). A description of environmental responsibility in the Finnish Curriculum reads, “[To make students] become acquainted with the rights and duties associated with acting in the environment” (p. 8). The difference is that the Chinese Curriculum only demonstrates the duties of an individual, whereas the Finnish Curriculum contains both personal duties and individual rights.

Life and career are competencies that target happiness and working life in a changeable world. In the Finnish Curriculum, “well-being” is widely used in connection with “health” or “safety”; for example, “in health education, it is essential to learn to understand the factors in the environment and in human activities that support and protect health and promote the development of competence that supports health, well-being, and safety” (Finnish Curriculum, p. 5). Concern for a healthy mental development is one of the most frequently mentioned aspects of Life and Career in the Finnish Curriculum; for example, “... support the pupil in recognising, expressing, and regulating his or her emotions” (Finnish Curriculum, p. 6). But all of the descriptions have a general meaning that is not specifically applicable to a science-related career. In the Chinese Curriculum, this subcategory is completely missing (N=0).

Personal and global social responsibilities involve tolerance and respect for people of other backgrounds, races, ethnicities and lifestyles; respect for one’s own cultural heritage and the heritage of others; and expanded cultural and global awareness and sensitivity (Musil, 2009; van den Akker, 2003). This subcategory is lacking in the Chinese Curriculum (N=1, 3.3%), where we find only this description: “Respect other persons’ emotions and attitudes in inquiry activities” (Chinese Curriculum, p. 8). In the Finnish Curriculum, Personal and social responsibility is mentioned 16 times, and different perspectives are illustrated. For example, this statement – “using versatile regional examples and topical news items, the pupils learn to perceive the natural environment and human activities in Finland, the Nordic countries, Europe, and other continents” (Finnish Curriculum, p. 8) – implies the need to understand other cultures and foster global awareness. The Finnish Curriculum also highlights the importance of respecting oneself and others: “the pupils practise their emotional skills and promote mental well-being, such as respecting themselves and others according to their age” (Finnish Curriculum, p. 3).

## DISCUSSION

The length of the Chinese text is much longer than the Finnish text. Moreover, the Chinese Curriculum includes detailed and well-organized objectives closely related to a specific content of a scientific discipline. Although the Finnish Curriculum does outline objectives and goals (*Lehrplan*) as does the Chinese Curriculum, it does not provide a detailed list of requirements for specific science content. The Chinese Curriculum is written from the desired outcomes of student learning, which usually starts with the words “Students should ...” By contrast, the Finnish Curriculum usually starts with the teachers’ objectives, using the words “Teachers should ...” These differences reflect the different functions of the national curriculum and the role of teachers in each country. The Chinese Curriculum is more closely aligned with the American curriculum tradition, in which teacher instructions follow precise checklists that describe students’ expected outcomes. By contrast, the Finnish Curriculum adheres to the *Didaktik* tradition. Teachers are treated as active professionals, and given only a guideline for teaching; they themselves select the content and construct a meaningful curriculum for their students.



The quantitative data give the following results: the density of appearance of competencies for the 21<sup>st</sup> century in the Chinese Curriculum is lower than in the Finnish Curriculum; the variance between the frequencies of each competency in the Chinese Curriculum is greater than in the Finnish Curriculum. These quantity differences illustrate potentially different aims of teaching and learning, which connect with different educational traditions. In Finland there has been a long tradition of having a short national level curriculum in order to give more autonomy to the local level for planning and implementation, thereby leaning to the *Didaktik* educational tradition. In addition, the Finnish Curriculum with its relatively balanced statements of the different competencies shows a conformity with the idea of *Bildung*, which seeks to develop the whole person, even in a subject curriculum. By contrast, the character of the Chinese Curriculum appears to be closer to the Anglo-American curriculum tradition, whose tendency has been to guide and systematize school education, with an emphasis on aims in science itself with limited linkage to the broader goals of Living in the World and insufficient values in personality aspects.

The shortage of aims in the Living in the World category in the Chinese Curriculum makes the argument above stronger, as the category Living in the World is the one intended to highlight the non-instrumental domain in science education, thus revealing the expectation of holistic individual development. In this category, Life and career and personal and social responsibilities are almost totally absent from the Chinese Curriculum, although in Chinese educational systems rational living and moral aspects of education are usually discussed. This feature implies the influence of an Anglo-American curriculum, which concentrates on the instrumental aspect of education, instead of regarding science education as a means to develop the whole person. However, since "Society and Moral Education" is an independent subject in Chinese primary schools, it makes the failure to integrate the moral and cultural aspects into the science Curriculum to some extent reasonable.

The Living in the World category is well balanced in the Finnish Curriculum, which shows that non-instrumental aspects have been considered in its development. This aligns closely with *Bildung-Didaktik*, in which moral values are among the key features (Autio, 2014). Yet the *Bildung-Didaktik* tradition *per se* cannot fully explain the emphasis on competencies in Living in the World in the Finnish Curriculum. For example, most units belonging to its subcategory "Personal and social responsibility" relate to goals for learning cultural geography. The subject area of cultural geography is not covered at all in the Chinese Curriculum. In fact, there are many historical and social reasons that account for the differences in subject area coverage in both Curricula. Thus, quantitative data alone cannot fully explain these divergences or, in some cases, even cover the underlying differences.

Nevertheless, how words are used in the texts could help explain some of the variants in emphases and tentative alignments of the curriculum theories. In the Chinese Curriculum terms or key words used to describe general objectives are "scientific literacy" and "scientific inquiry". In the Finnish Curriculum, "well-being", "community" and "sustainable development" are the terms that appear as broad aims. This distinction suggests that the Chinese Curriculum was designed to achieve specific outcomes in knowledge and skills. The aims of science education have been emphasised but mainly limited to the domain of science in the Chinese Curriculum. By contrast, the Finnish Curriculum includes aims for cultivating individuality and the student as a whole, with complementary aims outside science *per se*. Overall, the Chinese Curriculum is written from the perspective of "transferring knowledge to the learner", instead of emphasising the holistic development of students in society and for society. This indicates that the Chinese Curriculum tends to align with the Anglo-American tradition, while the Finnish Curriculum follows the *Bildung-Didaktik* tradition.

Coverage of aspects in the same competency differs in the two Curricula, although similarities are also found in the quantitative data. For example, ICT is only described as a tool for student presentation in the Chinese Curriculum. But in the Finnish Curriculum, goals for ethical use of ICT have been mentioned, revealing an underlying difference in educational ideology. This relates to the moral aspect of the *Bildung-Didaktik* tradition. Another example is seen in the category of Communication. Here the Chinese Curriculum is concerned only with the knowledge and skill to communicate information, whereas the Finnish Curriculum includes how to communicate emotion. This implies that the Finnish Curriculum has given consideration to the formation of the students themselves and how they are linked it to the world, ideas that adhere to the tradition of *Bildung-Didaktik*. The limitation of the Chinese Curriculum to instrumental means of communication and its focus on knowledge or skills alone suggests a limited connection with the *Bildung-Didaktik* and the heritage of Chinese wisdom, both of which include moral and self-development considerations.

Each Curriculum shares similar emphasis on Critical thinking and Creative thinking in quantity. However, this apparent similarity originates from different historical backgrounds. In a *Bildung-Didaktik* culture, critical thinking and creative thinking have been encouraged for a long time (Autio, 2014). It is an educational culture that values dialogue in each lesson and encourages critical thinking and creative thinking in class. Moreover, these competencies are considered the founding rationale for developing the holistic individual. By contrast, in traditional Chinese educational cultures, for example, that of Confucius in the Song Dynasty, education was intended to cultivate obedient citizens or to be a tool for society. With the modernization of Chinese education after 1900, and extensively after the 1980s, the curriculum aims started to change, and critical thinking and creativity

became valued. In particular, the pursuit and discussion of cultivating citizens with critical and creative thinking competencies started from societal needs in the new century, especially the needs of talented global-level Chinese scientists. Thus, needs outside society or needs for political reasons were the starting points for the emphasis on these cognitive skills in the new Chinese Curriculum. Emphasis on the interaction of education and society is one of the features of the Anglo-American curriculum tradition. By contrast, the Finnish Curriculum can trace its origins back to *Bildung* culture, with its aims of cultivating holistic, moral individuals and individual rationality, even if the emphasis is inevitably influenced by current societal needs learned from the Anglo-American curriculum tradition.

The quantitative results of the present research show that aims for “Citizenship” in the Chinese Curriculum are only a few degrees lower than in the Finnish Curriculum. However, citizenship is typically described in the Chinese Curriculum as being the duties each person owes society. In the Finnish Curriculum the description of citizenship begins with both the rights and duties of an individual to society. These similarities and differences are related to how citizenship and freedom are understood in each country. Science education in Finland is seen as a tool that enables the development of the learners’ individuality, which is consistent with the aims of the *Bildung-Didaktik* tradition. Finnish education has for years discussed the role of an active citizenry, whereby an individual lives in society and actively participates in constructing that society. It was Snellman who, in the nineteenth century, emphasised the role of *Bildung* and introduced questions related to citizenship into the Finnish education. By contrast, the Chinese Curriculum indicates that science education itself is the goal, and learning science is for educating the individual, who is expected to be a tool in building the society. However, the duty aspects of citizenship in both Curricula demonstrate a similarity. In Finland and China the idea of freedom is inward and limited: it rests on the premise that an individual lives in a society and must take responsibility for that society. However, the understanding of freedom in each country has evolved from different cultural traditions. The concept of freedom in the Finnish Curriculum derives from the *Bildung* culture. In China this understanding arises from traditional wisdom, such as Taoism.

Some similar features in the two Curricula show the resemblance of tasks or routes in designing a subject-based curriculum. “Inquiry” and “Information literacy” are the two major competencies appearing in both the Chinese and the Finnish Curricula, and are the competencies most closely related to knowledge and skills in science. This feature also relates with the aim changes of science education. Modern science education aims at cultivating reflective citizens with the ideas of science, understanding the nature of science, and ability to engage with science related issues at personal and social levels, instead of merely knowledge of science itself (Ferreira & Morais, 2013; OECD, 2013). Competency in the use of ICT is not emphasized in either primary science Curriculum, and the frequency of competency in ICT use is low in both, perhaps because ICT is a tool for building a learning and teaching environment or for supporting students’ learning processes and outcomes or products. It is understandable that it is only a minor component of both Curricula. Moreover, ICT itself is an important discipline in the Chinese education as a whole, which dilutes the emphasis of ICT in the science Curriculum. Although there is no specific subject teaching of ICT in the Finnish educational system, the national curriculum has declared the importance of ICT as one of the “seven transversal competences” in the core curriculum and the aims of ICT are integrated into each subject. These similarities illustrate that, although many generic competencies are integrated, instruction in the competencies related to certain subjects is still the main task in each disciplinary area.

## CONCLUDING REMARKS

This study investigated the integration of aims for learning 21<sup>st</sup> century competencies in the National Primary Science Curricula of China and Finland. Features that are both similar and different were found. In general, most of the 21<sup>st</sup> century competencies listed in the framework have been integrated into the Curriculum in both countries. Both Curricula showed an emphasis on aims related to science education, such as inquiry and information literacy. This echoes the aim changes of science education, which have been developed from narrow aims of knowledge or competencies within science itself to goals for understanding the nature of science, as well as being scientific literate.

But the results demonstrate more differences in the integration of the aims of 21<sup>st</sup> century competencies based on the adherence to different curriculum theories. The Chinese Curriculum has a tendency to align with the Anglo-American curriculum tradition, whereas the Finnish Curriculum is more aligned with the *Bildung-Didaktik* tradition. The aims for learning 21<sup>st</sup> century competencies that are integrated into the Finnish Curriculum are under the educational aims for development of a moral and holistic individual, which regards learning science as a means to that ends. However, the aims for learning 21<sup>st</sup> century competencies are not well integrated into the Chinese Curriculum. There is not enough consideration of cultivating the whole person in the science context. Formulating aims for scientific literacy is the main theme in the Chinese Curriculum, where a significant deficiency appears in the Living in the World category.

If we want to teach 21<sup>st</sup> century competencies by means of a disciplinary educational approach, it is important to clarify the purpose of education, which in our view should centre on cultivating a holistic individual. With that

purpose, moral, cognitive, aesthetic and practical elements all need to be considered in designing a curriculum. For example, in science education, both the Chinese and the Finnish Curricula show a shortage of aesthetic elements. Disciplinary knowledge and skills should not be left behind, but they must be seen as powerful resources for the ultimate educational ends. The Anglo-American traditions show an operational approach to implementing the teaching of 21<sup>st</sup> century competencies, and the Anglo-American national curriculum lists clearly expected outcomes. This could be helpful for subject teachers who lack experience in teaching these competencies. But the central purpose of education should be remembered as teachers become sophisticated in subject contents and skills. Countries can learn ways to achieve educational goals from each other. But ultimately, each country needs to develop its own theories and its practices in accordance with its particular history, society and traditions.

## REFERENCES

- Abd-El-Khalick, F., BouJaoude, S., Duschl, R., Lederman, N. G., Mamlok-Naaman, R., Hofstein, A., . . . Tuan, H. (2004). Inquiry in science education: International perspectives. *Science Education*, 88(3), 397-419. <https://doi.org/10.1002/sce.10118>
- Aktamis, H., & Ergin, O. (2008). The effect of scientific process skills education on students' scientific creativity, science attitudes and academic achievements. Paper presented at the *Asia-Pacific Forum on Science Learning and Teaching*, 9(1), 4.
- Ananiadou, K., & Claro, M. (2009). 21st century skills and competences for new millennium learners in OECD countries. *OECD Education working papers*. <https://doi.org/10.1787/218525261154>
- Anderson, R. D. (2007). Inquiry as an Organizing Theme for Science Curricula. In S. K. Abell & N.G. Lederman (Eds.), *Handbook of Research on Science Education* (pp. 807-830). London: Lawrence Erlbaum Associates, Publishers.
- Apple, M. W. (1993). The politics of official knowledge: Does a national curriculum make sense? *Discourse: Studies in the Cultural Politics of Education*, 14(1), 1-16. <https://doi.org/10.1080/0159630930140101>
- Autio, O., Kaivola, T., & Lavonen, J. (2007). Context-based approach in teaching science and technology. In E. Pehkonen, M. Ahtee, & J. Lavonen, (Eds.), *How Finns learn mathematics and science* (pp. 199-210). Rotterdam: Sense Publishers.
- Autio, T. (2014). The Internationalization of Curriculum Research. In W. Pinar (Ed.), *International handbook of curriculum research* (pp. 17-31). New York, NY: Routledge.
- Benade, L. (2014). Knowledge and educational research in the context of 'Twenty-first century learning'. *European Educational Research Journal*, 13(3), 338-349. <https://doi.org/10.2304/eeerj.2014.13.3.33>
- Binkley, M., Erstad, O., Herman, J., Raizen, S., Ripley, M., Miller-Ricci, M., & Rumble, M. (2012). Defining Twenty-First Century Skills. In P. Griffin, B. McGaw, & E. Care (Eds.), *Assessment and Teaching of 21st Century Skills* (pp. 17-66). Dordrecht: Springer Netherlands.
- Boh Podgornik, B., Dolničar, D., & Glažar, S. A. (2017). Does the Information Literacy of University Students Depend on their Scientific Literacy? *Eurasia Journal of Mathematics, Science and Technology Education*, 13(7), 3869-3891. <https://doi.org/10.12973/eurasia.2017.00762a>
- Burden, J., & Hall, A. (2005). Biology in the twenty first century: A new curriculum for school science. *Journal of Biological Education*, 40(1), 6-10. <https://doi.org/10.1080/00219266.2005.965600>
- Cropley, A. J. (2011). Definitions of creativity. In M. A. Runco, & S. R. Pritzker (Eds.), *Encyclopedia of creativity (second edition)* (pp. 358-368). San Diego: Academic Press. <http://dx.doi.org/10.1016/B978-0-12-375038-9.00066-2>
- Cuban, L. (1992). Curriculum Stability and Change. In P. W. Jackson (Ed.), *Handbook of Research on Curriculum* (pp. 216-247). NY: Macmillan.
- Deng, Z. (2015). Content, Joseph Schwab and German Didaktik. *Journal of Curriculum Studies*, 47(6), 773-786. <https://doi.org/10.1080/00220272.2015.1090628>
- Ding, B. P., & Wang, F. (2017). Didactics meets curriculum studies in the context of teacher education in mainland China: a historical and comparative perspective .In Lee J. C., Kennedy K. J. (Eds.), *Theorizing teaching and learning in Asia and Europe: A conversation between Chinese curriculum and European didactics*. Georgetown: Taylor and Francis.
- Ding, B.P. (2015). Science Education in Mainland China. In R. Gunstone (Ed.), *Encyclopedia of Science Education* (pp. 882-889). Dordrecht: Springer Netherlands.
- Eisenberg, M., Lowe, C. A., & Spitzer, K. L. (2004). *Information literacy: Essential skills for the information age* (2nd ed.). Westport, CT: Libraries Unlimited.

- European Union, Education and Culture DG. (2008). *Key Competences for lifelong learning: European reference framework*. Luxembourg: Office for Official Publications of the European Communities. Retrieved from <https://publications.europa.eu/en/publication-detail/-/publication/5719a044-b659-46de-b58b-606bc5b084c1>
- Eylon, B.-S., & Linn, M. C. (1988). Learning and Instruction: An Examination of Four Research Perspectives in Science Education. *Review of Educational Research*, 58(3), 251-301. <https://doi.org/10.3102/00346543058003251>
- Ferreira, S., & Morais, A. M. (2013). The nature of science in science curricula: Methods and concepts of analysis. *International Journal of Science Education*, 35(16), 2670-2691. <https://doi.org/10.1080/09500693.2011.621982>
- Finnish National Board of Education (2016). *National core curriculum for basic education 2014*. Helsinki: National Board of Education.
- Fisher, R. (1991). *Teaching children to think* (Reprinted.). Hempstead: Simon and Schuster Education.
- Goedegebuure, L., & Van Vught, F. (1996). Comparative higher education studies: The perspective from the policy sciences. *Higher Education*, 32(4), 371-394. <https://doi.org/10.1007/BF00133253>
- Hopmann, S. (2007). Restrained Teaching: The Common Core of Didaktik. *European Educational Research Journal*, 6(2), 109-124. <https://doi.org/10.2304/eeerj.2007.6.2.109>
- Hoskins, B., & Fredriksson, U. (2008). *Learning to learn: What is it and can it be measured?* Retrieved from <https://doi.org/10.2788/83908> <http://urn.kb.se/resolve?urn=urn:nbn:se:miun:diva-7810>
- John-Steiner, V. (2011). Collaboration. In M. A. Runco, & S. R. Pritzker (Eds.), *Encyclopedia of creativity (second edition)* (pp. 222-225). San Diego: Academic Press. <http://dx.doi.org/10.1016/B978-0-12-375038-9.00039-X>
- Kind, P. M., & Kind, V. (2007). Creativity in science education: Perspectives and challenges for developing school science. *Studies in Science Education*, 43, 1-37. Retrieved from <https://search.proquest.com/docview/222845211?accountid=11365>
- Lampiselkä, J., Ahtee, M., Pehkonen, E., Meri M. & Eloranta, V. (2007). Mathematics and science in Finnish comprehensive school. In E. Pehkonen, M. Ahtee, & J. Lavonen, (Eds.), *How Finns learn mathematics and science* (pp. 35-47). Rotterdam: Sense Publishers.
- Lavonen, J., & Laaksonen, S. (2009). Context of teaching and learning school science in Finland: Reflections on PISA 2006 results. *Journal of Research in Science Teaching*, 46(8), 922-944. <https://doi.org/10.1002/tea.20339>
- Mason, M. (2007). Critical thinking and learning. *Educational Philosophy and Theory*, 39(4), 339-349. <https://doi.org/10.1111/j.1469-5812.2007.00343.x>
- Mayring, P. (2015). Qualitative Content Analysis: Theoretical Background and Procedures. In A. Bikner-Ahsbahr, C. Knipping, & N. C. Presmeg (Ed.), *Approaches to Qualitative Research in Mathematics Education* (pp. 365-380). Springer Netherlands.
- Merriam-Webster online Dictionary*. Retrieved from <http://www.merriam-webster.com/dictionary/communication>
- Millar, R. (2006). Twenty first century science: Insights from the design and implementation of a scientific literacy approach in school science. *International Journal of Science Education*, 28(13), 1499-1521. <https://doi.org/10.1080/09500690600718344>
- Musil, C. (2009). Educating students for personal and social responsibility. In Jacoby, B. & Associates. *Civic engagement in higher education: Concepts and practices* (pp. 49-68). San Francisco: Jossey- Bass.
- National Research Council (2012). *Education for Life and Work: Developing Transferable Knowledge and Skills in the 21st Century*. Washington, DC: The National Academies Press.
- OECD. (2013). PISA draft science framework. <http://www.oecd.org/pisa/pisaproducts/Draft%20PISA%202015%20Science%20Framework%20.pdf>.
- OECD. (2014). *PISA 2012 results: What students know and can do (volume I, revised edition, February 2014)* Organisation for Economic Co-operation and Development. <https://doi.org/10.1787/9789264208780-en>
- OECD. (2016). *PISA 2015 results (volume I)* Organisation for Economic Co-operation and Development. <https://doi.org/10.1787/9789264266490-en>
- Oliva, P. (1997). The curriculum: Theoretical dimensions. In: New York: Longman.
- Ornstein, A. C., & Hunkins, F. P. (2013). *Curriculum: Foundations, principles, and issues*. Boston: Pearson.
- Pantić, N., & Wubbels, T. (2012). Competence-based teacher education: A change from didaktik to curriculum culture? *Journal of Curriculum Studies*, 44(1), 61-87. <https://doi.org/10.1080/00220272.2011.620633>
- Pinar, W. (2014). Introduction. In W. Pinar (Ed.), *International handbook of curriculum research* (pp. 1-16). New York, NY: Routledge.

- Preacher, K. J. (2001). Calculation for the chi-square test: An interactive calculation tool for chi-square tests of goodness of fit and independence [Computer software]. Retrieved from <http://quantpsy.org>
- Reimers F. M. & Chung C. K. (2016). A comparative study of the purposes of education in the twenty-first century. In Reimers F. M. & Chung C. K. (Eds.), *Teaching and learning for the twenty-first century: educational goals, policies, and curricula from six nations* (pp. 1-24). Cambridge: Harvard Education Press.
- Saari, A., Salmela, S., & Vilkkilä, J. (2014). Governing Autonomy. In W. Pinar (Ed.), *International handbook of curriculum research* (pp. 183-200). New York, NY: Routledge.
- Sahlberg, P. (2015). *Finnish lessons 2.0: what can the world learn from educational change in Finland?* (2nd ed.). New York: Teachers College Press.
- Schwarz, B. (2015). A Study on Professional Competence of Future Teacher Students as an Example of a Study Using Qualitative Content Analysis. In A. Bikner-Ahsbahr, C. Knipping, & N. C. Presmeg (Eds.), *Approaches to Qualitative Research in Mathematics Education* (pp. 381-399). Springer Netherlands.
- Tirri, K. (2016). Holistic perspectives on gifted education for the 21st century. In Ambrose, Don & Sternberg, J. Robert. (Ed.), *Giftedness and Talent in the 21st Century* (pp. 101-110): Rotterdam, the Netherlands: Sense Publishers.
- Trilling, B., & Fadel, C. (2009). *21st century skills: Learning for life in our times*. San Francisco, CA: John Wiley & Sons.
- Tröhler, D. (2014). International Curriculum Research. In W. Pinar (Ed.), *International handbook of curriculum research* (pp. 60-66). New York, NY: Routledge.
- Vahtivuori-Hänninen, S. H., Halinen, I., Niemi, H., Lavonen, J. M. J., Lipponen, L., & Multisilta, J. (2014). A new Finnish national core curriculum for basic education (2014) and technology as an integrated tool for learning (pp. 33-44). In Niemi, H., Multisilta, J., Lipponen, L. & Vivitsou, M. (Eds.), *Finnish Innovations & Technologies in Schools: a Guide towards New Ecosystems of Learning*. Rotterdam: Sense Publishers.
- van den Akker, J. (2003). The Science Curriculum: Between Ideals and Outcomes. In B.J. Fraser & K.G. Tobin (Eds.), *International Handbook of Science Education* (Vol. 1, pp. 421-449). Dordrecht; Boston; London: Kluwer Academic Publishers.
- Viera, A. J., & Garrett, J. M. (2005). Understanding inter observer agreement: the kappa statistic. *Fam Med*, 37(5), 360-363.
- Villalba, E. (2011). Critical thinking. In M. A. Runco, & S. R. Pritzker (Eds.), *Encyclopedia of creativity (second edition)* (pp. 323-325). San Diego: Academic Press. <http://dx.doi.org/10.1016/B978-0-12-375038-9.00057-1>
- Voogt, J., & Roblin, N. P. (2012). A comparative analysis of international frameworks for 21st century competences: Implications for national curriculum policies. *Journal of Curriculum Studies*, 44(3), 299-321. <https://doi.org/10.1080/00220272.2012.668938>
- Wang, Y., Lavonen, J., Tirri, K. (in press). 21st century competencies in the Chinese science curriculum. In X.Y. Du, H.Q. Liu, A. A. Jensen & F. Dervin (Eds.). *Nordic-Chinese Intersections on Education*. Palgrave MacMillan.
- Ward, T. B. (2011). Problem solving. In M. A. Runco, & S. R. Pritzker (Eds.), *Encyclopedia of creativity (second edition)* (pp. 254-260). San Diego: Academic Press. <http://dx.doi.org/10.1016/B978-0-12-375038-9.00181-3>
- Weber, R. (1990). *Quantitative Applications in the Social Sciences: Basic content analysis*: SAGE Publications Ltd.
- Westbury, I. (2000). Teaching as a reflective practice: what might Didaktik teach Curriculum? In S. Hopmann, K. Riquarts, & I. Westbury (Eds.), *Teaching as a reflective practice: the German Didaktik tradition*. Mahwah, NJ: Lawrence Erlbaum Associates.
- Zhang, H., & Gao, Z. (2014). Curriculum Studies in China. In W. Pinar (Ed.), *International handbook of curriculum research* (pp. 118-133). New York, NY: Routledge.
- Zhong, M. & Gao, L. B. (2007). Problems and Analysis on Primary Science Curriculum Reform. *Curriculum, teaching material, and method*, 6, 77-81.



For print copies of this issue or articles please send an e-mail to:

[print@modestum.co.uk](mailto:print@modestum.co.uk)



# The Necessary Knowledge for Online Education: Teaching and Learning to Produce Knowledge

Jacques Ferreira <sup>1</sup>, Marilda Behrens <sup>2</sup>, Patricia Torres <sup>2</sup>, Rita Marriott <sup>3\*</sup>

<sup>1</sup> Universidade Positivo, Curitiba, PR, BRAZIL

<sup>2</sup> Pontificia Universidade Catolica do Parana, Curitiba, PR, BRAZIL

<sup>3</sup> Universidade Tecnológica Federal do Parana, Curitiba, Paraná, BRAZIL

Received 16 October 2017 • Revised 17 February 2018 • Accepted 18 February 2018

## ABSTRACT

This article presents qualitative research of a case study type, carried out with a group of 27 educators who were strengthening their knowledge of online education to a greater depth. Online education requires pedagogical mediation and the skills and competencies to work with technological resources which promote interaction, collaboration, and co-learning. From this perspective, the following research question was posed: what is the knowledge needed for educators to work in online education in order to promote knowledge production? The data collected was analysed according to Bardin (2011) and the assistance of Atlas Ti software. Based on the research findings it was possible to identify three main knowledge areas for mediating teaching and learning processes designed to produce knowledge, essential for teaching online.

**Keywords:** online competencies and skills, distance education, online education, knowledge production, teaching

## INTRODUCTION

The strong influence that the information and the knowledge society exert in social contexts is a consequence of the rapid technological progress and evolution of the networked society; consequently, this influence has greatly affected education, especially the way to communicate and propose methodologies that foster meaningful learning. However, the use of just information and communication technologies (ICT) in education does not guarantee innovation and effective learning for students. As such, we begin this paper with the premise that pedagogical knowledge allied with technological knowledge is essential for teachers who work or intend to work with online education.

Online education can refer to completely virtual lessons, meaning there is no physical contact involved, but it can also include blended courses that mix face-to-face and virtual meetings, such as face-to-face courses with complementary activities performed on the Internet outside the classroom, which are common today. In online education, there is an integration of “face-to-face classes with virtual classes and activities”, as Moran explains, “making time and space more flexible, extending the teaching and learning spaces that were until now practically confined to the classroom<sup>1</sup>” (Moran, 2006, p. 42). Online education offered by means of the Internet surpasses the conservative vision of distance education (DE), in which courses are delivered by post and are designed to reach people who live in distant places.

As a result of the social changes of the 21st century and the strong presence of ICTs, contemporary society requires professionals who are prepared to employ technological resources from a critical and ethical perspective. This approach means that methodologies capable of accommodating these technological innovations must be offered and, for this, teachers must use them with discernment in the teaching and learning process. The university,

<sup>1</sup> All quotes in this paper were translated into English from the source in Portuguese or Spanish by the authors.

#### Contribution of this paper to the literature

- The methodological process, data and findings of the qualitative research are analysed in a well-grounded and original way.
- Research findings identified the necessary knowledge for online teaching.
- The study can have both a pedagogical, practical and technological impact on teacher training courses and can directly influence online teaching and teachers.

among other educational institutions, also becomes responsible for responding to this demand to prepare professionals, but teachers must be aware and ready to respond to this demand.

In Brazil and around the world, there have been several changes in teaching and learning methods in institutions of higher education that offer distance learning courses (Torres & Siqueira, 2012). Some of these changes include the growing number of: (a) students enrolling in distance learning courses; (b) courses being offered online; (c) universities adopting this modality; (d) governmental regulations and (e) marketing actions. Besides, several of these programs are being internationalised. These developments have reflected on face-to-face teaching activities, with an increasing number of *online* episodes being incorporated into curriculums and into teachers' planning (Siqueira, Hilu, & Torres, 2015).

Initial and continuing teachers' education has seen a significant growth in the last decade in Brazil, which has even disproved the theory that these courses would be of less value in education. It is believed that the reason this education is now so popular is because Article 62 of Brazil's own National Education Guidelines Law - LDBEN 9394/96, clearly states that initial and continuing teachers' education can be accomplished through the use of DE resources and technologies. Article 80 highlights that "Public power will encourage the development and delivery of DE programs at all levels and modalities of education and continuing education" (Brasil, 1996). The effects of this law could be felt from 2009 with a significant increase in the number of enrolments for distance courses.

DE presents different forms of teaching and learning that carry specific terminologies such as *online learning*, *e-learning*, *blended learning*, *mobile learning*, and *MOOC*. Online education is a form of DE which involves the Internet, and is usually accessed through a number of devices, such as a computer, tablet, or smartphone. Through interaction and communication in synchronous or asynchronous ways, online education can overcome the feeling of isolation, typical of many distance courses, by allowing students to experience a sense of belonging to a virtual class (Torres, 2004).

From this perspective of online education, this article will discuss the findings presented by educators involved in research on the use of online education in the process of teaching and learning. Qualitative research, of the case-study type, was conducted on a group of 27 master's and doctoral students who work at different levels of education and who were attending meetings of the research group Pedagogical Practice in Teaching and Learning with Educational Technologies (PRAPETEC) at the Catholic University of Paraná (PUCPR), in Brazil.

In the research group, students discussed and reflected on issues related to online education and teaching practices, deepening their understanding, exchanging and producing knowledge in debates that were conducted in person and online. Online activities were performed in the Eureka virtual learning environment (VLE). In the face-to-face meetings, researchers reflected on topics, raised questions from the assigned readings and elaborated synthesis of the relevant points covered by the research group. From the readings and the syntheses performed, they created concept maps to organise and represent knowledge and to find possible solutions to the problem being researched. Concept mapping was used in order to promote meaningful learning as the creation of concept maps can significantly contribute to promote a shift from rote-mode learning to meaningful learning, encouraging analysis, synthesis, and critical thinking (Marriott & Torres, 2014). In the online meetings, the researchers developed activities in the VLE and established discussion forums on the subject. The research group held 15 meetings during the first half of 2016 and eight online activities, one of which concerned a discussion forum about online education.

The discussions and reflections presented in this article were extracted from the thematic forum on online education hosted on Eureka in which the following research question was posed: what is the knowledge necessary for educators to work in online education in order to promote knowledge production? The objective of the research was to analyse course participants' perceptions of online education in regard to the related teaching and learning processes focused on the production of knowledge.

## ONLINE EDUCATION

Online education has democratised information and communication, bringing knowledge and learning to students who are geographically separated from the teacher, thus allowing knowledge to overcome physical distances. Among many existing technologies, videoconferencing, teleconferencing, and VLEs can be highlighted as the most used didactic resources in online education. It is in these online teaching and learning circumstances

that many training processes occur across Brazil, and this ensures the education and professional development of many teachers who seek to strengthen their pedagogical practice. The cultural and technological reality of Brazil is vast and much differentiated, and online education must be provided in a meaningful, innovative, and qualitative manner.

Online education has been assisting “the teacher who works in online courses, where new teaching temporalities need to be considered so that he/she can plan, develop and execute the planned classes” (Kenski, 2013, p. 119). Nevertheless, online teachers are being faced with a new paradigm in which the students, mediated by their teachers, produce their knowledge in an autonomous way and are able to ‘learn how to learn’ and to learn collaboratively. As such, for teachers to act in an emerging context based on virtuality and interactivity, both pedagogical and technological knowledge is necessary, but are only these two types of knowledge enough?

## KNOWLEDGE NEEDED FOR ONLINE EDUCATION

Given the new educational paradigm in which today’s students enjoy the connectivity and the sharing of information, the different modalities of education bring challenges to pedagogical practice and encourage teachers to seek professional development so that they can work in online education with relevance, quality, and commitment. In this sense, there is a need to determine the necessary knowledge that enables teachers to work with online education in a competent way in relation to the process of teaching and learning.

Teachers’ academic education is influenced by the paradigms of education and, as a result, educational practice is determined according to the paradigm that the teacher establishes in his/her teaching. According to Behrens (2005), educational paradigms may be defined as conservative or innovative/emerging. The complexity presented by Morin (2000) appears as an innovative paradigm that proposes a reform of conventional thinking, and this has been much discussed in education, mainly in regard to its relation with technology.

Moreover, the complexity paradigm brings us a model of circularity that “is favoured by the possibilities of effective self-organising and self-creative processes that information and communication technologies can provide, more specifically by Web 2.0, the collaborative web.” Online education with the support of ICT based on collaboration allows co-creation and co-learning that “privileges circularity and feedback inherent to a complex approach” (Torres & Hilu, 2017, p. 28).

Just as in face-to-face teaching, in which the teacher uses technology, mainly a VLE, as a resource to store *slides* of classroom lessons, the complexity approach seeks to overcome conservative actions in online education. The complexity view is essential for pedagogical mediation in online education, as it allows the teacher to transcend complex knowledge relating to online education without dismissing the need to overcome the contradictions and difficulties found in this type of teaching modality. On the other hand, the teacher cannot simply adopt the technological resources in a conservative way and be a mere instructor or someone only passing on contents because, in order to boost the production of knowledge, the teacher must acquire a form of knowledge that, in Tardif’s vision (2010, p. 10), is called “professional practice”:

An online education teacher must explore and use all of the technological possibilities related to the process of teaching and learning, and have a clear understanding of the knowledge embedded in this network. Therefore, when using technological resources, the teacher must clearly understand that these resources are designed to foster learning, in the same way that ICT fosters socialisation and collaboration in the production of knowledge. However, it is necessary that the teacher masters the technologies used in DE, especially in online education. The technological knowledge of a teacher is related to his/her technical knowledge, his ability to interact with and adopt technologies as resources in his/her teaching activity.

Online education enables various technological resources to be used to explore a wide range of information and knowledge. It is important to highlight that learning in online education can happen in any time and circumstance, depending on the technology and pedagogical proposal used.

It is also imperative to draw attention to a knowledge-related skill that must be constantly applied in conjunction with the knowledge required for online education: the skill of learning throughout life and from new scenarios that are presented from the different relations created through working with this type of education. This skill prioritises new methods of autonomous learning, collaborative learning, interactivity, and connectivity, all of which arise in the complex role of being a teacher of online education.

## METHODOLOGICAL RESEARCH APPROACH

The objective of this research was to analyse educators’ perceptions about online education in regard to teaching and learning processes focused on producing knowledge. The developed research presents a qualitative approach of a case-study type and of an interpretive nature. Qualitative research allows the researcher to interpret the phenomena of education in relation to their environment. From this perspective, the researcher is able to establish

a true interpretation of occurrences and educational facts in the search to understand the complexity of the education and the educational processes.

The research in question is of the case-study type, as this format allows researching a case in detail, specifically linking the thematic to the theory and pedagogical practice of teachers' education proposed by the PRAPETEC research group. Case-study research allows the researcher to delve deeper into details of specific situations. According to Bogdan and Biklen (1994, p. 89) "[...] the case study consists of the detailed observation of a context or individual, of a single source of documents or of a specific event."

The sample used to conduct the research and apply the data collection methods was made up of 27 educators who were masters or doctoral students belonging to the research group PRAPETEC. They were mainly women over the age of thirty who work at different levels of education (from kindergarten to higher education). Of the 27 subjects, 23 had experience in DE, 25 were female (15 pedagogues and 10 with another teaching degree<sup>2</sup>) and two were male (one pedagogue and one with another teaching degree).

All subjects of the research participated in several of the online forums; however, for this article, only the discussion forum concerning online education was investigated because, in this forum, the educators could discuss online education and the essential knowledge teachers required to be able to work in this model of teaching.

The data collection was performed based on the contributions in the online discussion forum, which enabled the participants' responses to be surveyed. Two questions about online education were presented and these generated discussion in the VLE. The subjects remained anonymous during all phases of data collection and data analysis. Free and informed consent forms were made available to the research subjects during the research group's face-to-face meetings. All educators involved were over the age of 18 and freely agreed to participate in the study. The research developed in this article was approved by the Research Ethics Committee at the Pontifical Catholic University of Parana (PUCPR) under the legal number 852.829.

The responses made in the forum were copied from the VLE and pasted into a Microsoft Word document; this was in order to enable content analysis and to maintain research ethics standards. The answers that the educators gave in the forum were coded as follows:

- The acronym "RFD" stands for a Response in the Discussion forum.
- The letter "E" next to a numeric expression such as "01" corresponds to the identification number for each Educator who participated in the research.

Combining this information creates a specific code; for example, "RFDE01," which has the following meaning: "Response in the Discussion Forum from Educator 01." A code with this information was created for each forum response. After forum responses were assigned identifying codes in the text of the Word document, the responses were entered into Atlas Ti qualitative-data-analysis software (the Mac version of this software) in order to begin performing the content analysis process recommended by Bardin (2011). This process of identification and coding was performed for the 27 responses in the discussion forum provided by the research subjects.

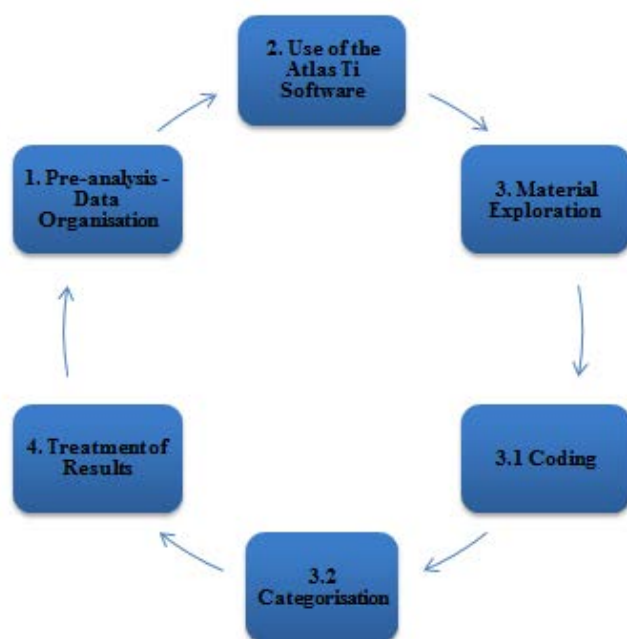
## BARDIN'S CONTENT ANALYSES PERSPECTIVE

Data analysis is a very important part of research, as it allows the researcher to organise and interpret the data collected. At this stage, the researcher seeks to organise and structure the data in order to discern meanings that can be used as research evidence. The qualitative approach to data analysis is dynamic and varied; the researcher may choose to perform different types of data analysis in order to obtain a better answer to his research problem. The researcher, while performing the data analysis, must possess theoretical knowledge about the analysis technique that will be performed. Currently, there are different techniques for organising and analysing qualitative data; in this article, the content analysis method recommended by Bardin (2011) was employed to the responses of the discussion forum that was held on Eureka.

Content analysis as a qualitative analysis technique can be performed on various text materials from any source. To Bardin (2011, p. 37), content analysis "[...] is a set of communication analysis techniques. It is not a tool, but a range of implements; or, more precisely, it can be described as a single instrument, but one that allows for a great disparity of forms and is adaptable to a very wide field of application [...]." Content analysis can also be performed on images and sounds and it can be conducted in different ways; there is no rule to be followed to complete an analysis process. Considering the many ways of performing content analysis, the technique proposed by Bardin (2011) was used as a guide. From Bardin's perspective, the stages of content analysis are the following: pre-analysis,

---

<sup>2</sup> In Brazil, the holder of a teaching degree is entitled to be a teacher in kindergarten, elementary, secondary and high schools in the area of knowledge the degree was taken, such as: biology, mathematics, physics, chemistry, languages, history, philosophy, pedagogy, social sciences, arts, and physical education.



**Figure 1.** Stages of the content analysis process, which was performed with the help of Atlas Ti software on the discussion forum responses

material exploration, and treatment of results. The first stage, the pre-analysis, corresponds to the organisation of the collected material.

The objective of the **pre-analysis** is to organise the data; to choose the documents that will be part of the data analysis, to create code indicators to facilitate the analysis. At this stage of the content analysis, the responses from the discussion forum were organised and a code was created to identify each response made by the educators in the discussion forum. For the *corpus* (the set of documents used) of the content analysis, all of the answers posted on the discussion forum were used. The **exploration** stage of the material is the moment in which the researcher performs the content analysis: a systematic application of the analysis technique. In this stage, coding was performed, which concerns the reading of the responses given and the creation of codes to differentiate them in the data-collection instrument. Coding involves the systematic organisation of data for later classification and categorisation. Therefore, after coding, the next step is categorisation which, according to Bardin (2011, p. 133) “[...] corresponds to a transformation - made according to precise rules - of the raw text data, which is processed by clipping, aggregation and enumeration, and achieves a representation of the content or its expression, which is likely to clarify to the analyst the characteristics of the text.” Categorisation is presented as a process that allows codes to be grouped, segregated, or regrouped with the purpose of consolidating a meaning.

At the **treatment of results** stage, according to Bardin (2011, p. 131), “[...] the raw results are treated in such a way as to become meaningful and valid [...] and the researcher [...] having at his/her disposal meaningful and trustworthy results, can then propose inferences and interpretations in advance towards the intended objectives - or that concern other unexpected discoveries.”

We now present the analysis of data collected in this investigation following Bardin’s perspective.

## ANALYSIS PROCESS FOR THE COLLECTED DATA

In our research, the content analysis of the discussion forum responses was performed using the Atlas Ti software, which allows the researcher to perform qualitative analysis of the collected data. According to Gibbs (2009), qualitative data analysis software provide ease-of-use and advantages for organising and analysing data, making it easier and more accurate; however, the software itself does not perform data analysis, this is done by the researcher, along with the job of establishing its relationship with the object of study. Atlas Ti is a qualitative data analysis software tool widely used for research in the field of education; it affords the management, organisation, grouping, and regrouping of data.

To clarify the steps of the content analysis performed on the discussion forum responses using Atlas Ti software, **Figure 1** is presented, illustrating the steps of the data-analysis process and providing an explanation for each.

*Step 1. Pre-analysis - Data Organisation:* **At this first stage**, the data entered into the software was sourced from the discussion forum that was held on Eureka, which had the objective of discussing online education and the knowledge necessary for its teaching. The 27 answers given by the educators in the discussion forum were entered into the software.

*Step 2. Use of the Atlas Ti Software:* **At the second stage**, the answers from the discussion forum were identified by a code that followed the following format: "RFDE01" - "Response on the Discussion Forum from Educator 01," where educator 01 represents one of the subjects who participated in the Eureka activity. For example, the code "RFDE13" means that the following is a response on the discussion forum from educator 13. The coded discussion forum responses were saved in Word format and inserted into the Atlas Ti software to begin the analysis process.

*Step 3. Material Exploration:* In the material exploration stage, the answers from the discussion forum followed two stages: coding and categorisation; these steps correspond to the analysis of the answers made by the educators involved in the research. A code was created for each questionnaire response.

*Step 3.1 Coding:* The coding stage was performed by creating codes for later categorisation. The codes represent a system of symbols that allow the representation of information. The codes were created chronologically as the reading of the responses in the discussion forum was being performed. For each response, a code was created, and identical or similar responses received the same previously created code.

*Step 3.2 Categorisation:* **At this stage**, we placed codes in a set in regard to occurrence or similarity. This allowed the researcher to group the data to consolidate a meaning. The codes that were grouped by similarity and occurrence gave rise to the categories of analysis.

After the coding was completed, the code that presented the highest occurrence and similarity of responses was visualised in Atlas Ti. All codes with high rates of occurrence and similarity of responses were analysed by the researchers. The analysis of the code was conducted as follows: 1 - Careful reading of the answers of the participants; 2- Reflection by the researchers on each response; 3- The identification and creation of groups with points of convergence between the answers in order to consolidate a meaning; 4- The creation of categories from the educators' answers.

*Step 4. Treatment of Results:* **We then reached the last stage.** After the educators' responses were learnt, they became indicators for creating categories. In order to create the categories, the researchers sought the meaning of the educators' answers and, as they were also interested in discerning the intensity of logical semantic meanings, they decided to quantify the absolute and relative frequencies of the answers. For content analysis to be performed in the responses of the discussion forum, a table was drawn to present the created categories and some of their indicators (answers). The table below presents three responses that were used as examples for the creation of categories and the total responses for each category. The question asked in the discussion forum on Eureka was as follows:

Problematization presented in the discussion forum: (1) What is the importance of online education for contemporary education? And (2) What knowledge is essential in order for an educator to work in this type of education before beginning the process of teaching and learning to produce knowledge?

For the first question on the discussion forum, the answer that had the highest rate of occurrence (21) was that online education is important to education because it allows collaboration. The questionnaire was designed to identify the relevance of online education today. **Table 1** presents the categories that were created from the participants' answers:



**Table 1.** Some reasons highlighted by the surveyed educators to justify the importance of collaboration in online Education

Answers	Teachers
<b>(CATEGORY) - In Collaboration to obtain Knowledge</b>	<b>Total of answers: 6</b>
"Online education allows students to learn more and more about using technology, social networks, etc. I use social networks a lot to collaborate in regard to information and learning [...]."	RFDE03
"In this type of DE, online education allows interaction between teachers and students and, in particular, collaboration conducted through various technologies in regard to information and knowledge that can contribute to the education of many people. In online education I try to collaborate with all involved, as this affords better interaction."	RFDE19
"In online education, we have the possibility to interact, integrate and collaborate with all those involved, disseminating information and knowledge."	RFDE25
<b>(CATEGORY) - In Learning</b>	<b>Total of answers: 15</b>
"Online education enables a collaboration of the teacher and student's knowledge, both interacting and exchanging information and knowledge mediated by information and communication technologies. Online education allows learning to be shared openly and dynamically."	RFDE08
"Online education offers a wide range of resources for teachers, allowing them to be more closely integrated with students, thus breaking the physical barriers of the classroom and allowing learning to be mediated by technologies. The interaction between teachers and students allows collaboration; in my point of view, this is very important, but the collaboration of all involved in the process allows, without a doubt, a form of learning in which there is exchange and sharing, something that many times does not occur in face-to-face teaching."	RFDE022
"[...] collaboration is of great relevance in online education, the teacher and the student share knowledge and life experiences. Collaboration, when done by everyone online, promotes collaborative learning."	RFDE13

Source: table built from data collected

In **Table 1**, it is possible to verify that 15 educators mentioned that the existing collaboration in online education assists learning. Given the educators' responses, the relationship between collaboration and learning becomes evident. In this study, the researchers understand that collaboration in online education is fundamental to learning, making it necessary knowledge for online teaching. In this sense, "Online learning is a social and individual activity at the same time. Social skills are an important aspect of Internet interaction, especially when they involve collaboration" (Kearsley, 2011, p. 66). The collaboration that occurs in this type of education, also called collaborative learning, is generated in learning situations in which students, in pairs or groups, not only assist each other but also share goals and meaningful exchanges amongst themselves and the teacher (Torres & Irala, 2014).

In online education, collaborative learning can occur in interfaces such as forums, messenger applications, e-mails, and social media, among others. According to Okada, Mikroyannidis, Meister, and Little (2012), social media provides co-learning, open, and collaborative learning. The co-learning used in online education can provide increased opportunities for co-authoring, the creation of open-education resources (OER), the promotion and exchange of *feedback* and comments, motivation for users to share their productions and their learning processes, contributions to disseminate knowledge, practices and paths for co-learning, instant answers and editing, availability for any web user to contribute, ease of communication; and low costs (Okada et al., 2012).

Considering the analysis made, it is important for online education teachers to plan and offer to students methodologies that allow collaboration, which will give them opportunities to discuss, argue, present points of view, collaborate, and share and produce knowledge, both individually and collectively. This can be performed through existing collaboration in online education, using technology to disseminate knowledge in a collaborative and open way. This can become a recurring practice in education, especially in teachers' education and, in the case of online education, in its pedagogical mediation.

In relation to the second question asked on the discussion forum, the answer that had the highest occurrence (23) was that the essential knowledge required for teachers to work in online education before beginning the process of teaching and learning is for the teachers themselves to have already been educated in online education. The question in the forum aimed to identify the knowledge required for online teaching. We agree with this research evidence, because it is very important for teachers who work in this modality of education to have specific training. In many educational institutions, in the start of teachers' education there is no subject which addresses online teaching, a type of education that is becoming more popular every day and one which from which many teachers graduate from in Brazil. In relation to DE, Brazilian undergraduate teaching courses have seen a significant increase in this type of education. **Table 2** shows the categories that were created based on participants' answers:

**Table 2.** Some reasons highlighted by the surveyed educators to justify the importance of training to build essential knowledge for teaching in online education courses

<b>Answers</b>	<b>Teachers</b>
<b>(CATEGORY) - Technological knowledge</b>	
<b>Total of answers: 05</b>	
"[...] one type of knowledge is related to technological knowledge, and concerns the ability to use and mediate online education. I believe that this knowledge must be provided through specific education in this modality of teaching."	RFDE01
"It is important for the teacher to receive training in online education. [...] a type of knowledge that I consider essential is the technological knowledge of the teacher. It is fundamental, and without it, the teacher cannot teach online education."	RFDE12
"I believe that in order to obtain knowledge about online education, it is necessary to have a good training in this modality of DE. Therefore, I believe that many types of knowledge are essential, such as ICT-related knowledge."	RFDE11
<b>(CATEGORY) - Practical Knowledge</b>	
<b>Total of answers: 6</b>	
"I am a teacher of several distance-learning courses, but I have never had any training in this modality of teaching. I think it is very pertinent that universities provide teachers with education related to DE. I did not learn to be a DE teacher at university; I became a teacher in this modality of teaching through practice, employing trial and error in regard to the process of teaching and learning in online education."	RFDE27
"Training to work in online education is fundamental, whether it is initial or continuing. My experience as a teacher in DE is completely practical, as I obtained no theoretical knowledge from my initial formation."	RFDE07
"Teacher education is essential for online education. I have become a teacher of DE due to hands-on experience. I used to clarify doubts with colleagues who work in online education" [...]	RFDE19
<b>(CATEGORY) - Pedagogical Knowledge</b>	
<b>Total of answers: 12</b>	
"Teacher education is essential to those who want to work with teaching. Pedagogical knowledge is paramount for the teacher to teach in both face-to-face and distance learning."	RFDE03
"[...] Tardif mentions vocational knowledge as one of the skills that is part of teachers' education. Online education is no different, the teacher needs to have training about online education; knowledge of this type of DE is required to teach and learn and, thus, produce knowledge. The knowledge acquired from teachers' education is essential."	RFDE24
"Having solid education to work in online education helps the process of teaching and learning in this context; without this, the teacher will not be able to deliver quality work to produce knowledge."	RFDE15

Source: Table built from data collected

In **Table 2**, it is possible to verify that 12 educators mentioned that the knowledge required to teach online must be acquired from teacher education, with pedagogical knowledge being central for online teaching. Given the evidence gained from the analysis conducted, it can be agreed that pedagogical knowledge related to the teaching and learning process is essential for online education, as well as for any educational principle.

Teaching knowledge is built through the professionalisation and professional development of teachers. It is a "plural knowledge, formed of diverse knowledge types from training institutions, vocational training, curriculums and daily practice." (Tardif, 2010, p. 54) The necessary knowledge required for a teacher to work in online education must stem from the same premise expressed by Tardif; however, it is believed that the necessary knowledge for the online education teacher should be given during education, whether it is initial or continuing.

Considering the categories created from the teachers' responses, it was possible to identify the different types of knowledge required by the online education teacher, among which are: technological knowledge; professional practical knowledge; and pedagogical knowledge, such as essential knowledge to mediate the process of teaching and learning.

## FINAL CONSIDERATIONS

This research on the importance of online education and the essential knowledge that teachers require to work in this modality of education presents an advancement that needs to be considered in regard to the teaching and learning process to produce knowledge. However, it is necessary to consider that the findings of this case study research originated from a group of educators doing their master's or doctoral studies on a post-graduate Education program. The collaboration of the research participants and the deepening of the theoretical research made it possible to see that, in the online modality, the types of knowledge required include major fields of pedagogical, practical, and technological dimensions. In a true network that generates learning, this alliance between these forms of knowledge compose a weave, each one with its own importance, but all forms of knowledge need to manifest

themselves in the educational process, in particular by generating methodologies that embrace different procedures, such as the much needed problematization and contextualisation required to produce knowledge.

Once the relevance of each dimension is safeguarded, the *pedagogical* knowledge becomes directly linked to an epistemological view, as it portrays one's teaching choice, which is linked to one's approach to humanity, society, and the world. At this moment, the overcoming of the conservative view points towards the new complexity paradigm (Morin, 2000) which implies considering the student as an entity, that is, as a whole. So, in order to learn, it is necessary to consider multiple factors, like reason, but also to consider emotions, subjectivity, and lovingness, among others. In this respect, *pedagogical* knowledge offers methodological processes that involve both interactivity and collaboration, as indicated by the participants of this research. Such care becomes relevant and essential for bringing teachers and students increasingly closer together in regard to the expressive use of sharing and collaborative interfaces in the search to produce knowledge.

*Practical* knowledge involves considering the experiences of teachers, which they acquired throughout their lives as students and were further enhanced when they chose to become professionals in education. *Practical* knowledge is produced from experience as a teacher and from critical reflection from daily work in the classroom. *Practical* knowledge also depends on epistemological views allied with pedagogical knowledge, which is essential in the initial and continuing teacher education and involves choosing a conception or approach that ensures the ability to teach and to learn. Teaching methodologies, in some cases called active methodologies, have been widely discussed in an effort to meet new demands, including procedures that embrace interaction and collaboration in peer learning and involve the use of virtual resources.

In the alliance between pedagogical knowledge and practical knowledge, *technological* knowledge is added by those educators who wish to develop skills and competences in online or face-to-face teaching. *Technological* knowledge is knowledge that the teacher must apply in the use and adoption of virtual environments, their resources, and their interfaces. In this online network, participants are senders, receivers, and knowledge producers and, in this process, students must access information and resources to develop collaborative activities, engage in dialogue with each other, and establish connections. Students can enter new information or take it over in order to transform it in something new. The new complexity paradigm requires more than memorising contents. It concerns the addressing of real problems, leading to the search and elaboration of information to transform it into knowledge and in this process produce meaningful knowledge that encourages learning for life and not only learning to pass a test. The idea is to educate students and teachers as conscious, critical beings, capable of managing the available information and transforming it into relevant knowledge.

*Pedagogical*, *practical*, and *technological* knowledge, among others, involve performing the necessary research, analysis, preparation, reflection, and actions to form critical and thinking citizens required for this century, fostering a networked and interconnected circulation of thoughts, stimulating information not merely for communication's sake, but also to solve possible problems that humanity is facing.

## REFERENCES

- Bardin, L. (2011). *Análise de Conteúdo [Content Analysis]*. São Paulo: Edições 70.
- Behrens, M. A. (2005). *O Paradigma Emergente e a Prática Pedagógica [The Emerging Paradigm and Teaching Practice]*. Petrópolis, RJ: Vozes.
- Bogdan, R. C., & Biklen, S. K. (1994). *Investigação Qualitativa em Educação [Qualitative Investigation in Education]*. Porto: Editora Porto.
- Brasil. (1996). Lei de Diretrizes e Bases da Educação Nacional. Lei no 9.394, de 20 de Dezembro de 1996. Estabelece as diretrizes e bases da educação nacional [National Brazilian Guidelines for Education]. *Diário Oficial da União*, Brasília, DF, 23 dez.
- Gibbs, G. (2009). *Análise de dados Qualitativos [Analysis of Qualitative Data]*. Porto Alegre: Artmed.
- Kearsley, G. (2011). *Educação Online: aprendendo e ensinando [Online education; learning and teaching]*. São Paulo: Cengage Learning.
- Kenski, V. M. (2013). *Tecnologias e Tempo Docente [Technologies and teachers' time]*. Campinas, SP: Papirus.
- Marriott, R. de C. V., & Torres, P. L. (2014). Mapas Conceituais uma ferramenta para a construção de uma cartografia do conhecimento [Concept maps – a tool for the construction of knowledge cartography]. In: Torres, Patricia (Ed.) *Complexidade – Redes e Conexões na Produção do Conhecimento*. Curitiba: SENAR-PR. P. 173-221.
- Moran, J. M. (2006). Contribuições para uma pedagogia da educação on-line [Contributions for online pedagogy] In M. Silva *Educação Online: teorias, práticas, legislação, formação corporativa* (2<sup>nd</sup> Ed.), São Paulo: Loyola. p. 41-53.

- Morin, E. (2000). *Os sete saberes necessários à Educação do Futuro [The seven necessary knowledges for future education]* (2. ed.), São Paulo: Cortez; Brasília, DF: UNESCO.
- Okada, A., Mikroyannidis, A., Meister, I., & Little, S. (2012). Coaprendizagem através de REA e Redes Sociais [Coelearning via OER and Social Networks]. In: Okada, Alexandra. *Open Educational Resources and Social Networks: Co-Learning and Professional Development*. London: Scholio Educational Research & Publishing.
- Siqueira, L. M. M., Hilu, L., & Torres, P. L. (2015). Formando professores universitários para o uso de redes sociais na aprendizagem [Education university teachers to use social networks for learning]. In: Miguel, Maria Elisabeth Blanck; Ferreira, Jacques de Lima. (Eds.). *Formação de professores: história, políticas educacionais e práticas pedagógicas* (1 ed.), Curitiba: Appris, v. 1, p. 281-295.
- Tardif, M. (2010). *Saberes docentes e formação profissional [Teaching knowledge and professional education]*. Petrópolis: Vozes.
- Torres, P. L. (2004). *Laboratório on line de aprendizagem: uma proposta crítica de aprendizagem colaborativa para a educação [Online learning lab: a critical proposal of collaborative learning for education]*. Tubarão: Editora Unisul.
- Torres, P. L., & Hilu, L. (2017). O paradigma da complexidade e o desafio da virtualização e da transformação da educação [The complexity paradigm and the challenge of vidualization and the transformation of education]. In: Núñez, María Elena Chan e Rama, Claudio (Eds.). *Futuro de los sistemas y ambientes educativos mediados por TIC*. Guadalajara: Ed. Universidad de Guadalajara. p. 25-39.
- Torres, P. L., & Irala, E. (2014). Aprendizagem Colaborativa: teoria e prática [Collaborative learning: theory and practice]. In: Torres, Patrícia Lupion (Ed.). *Complexidade: redes e conexões na produção do conhecimento*. Curitiba: SENAR - PR, p. 61-94.
- Torres, P., & Siqueira, L. (2012). Educação virtual nas universidades: as contribuições da aprendizagem Colaborativa [Virtual education in universities: the contribution of collaborative learning]. *Revista da história da educação latino-americana*, 14(19), 175-204. <https://doi.org/10.19053/01227238.1991>

**<http://www.ejmste.com>**

## Designing a System for English Evaluation and Teaching Devices: A PZB and TAM Model Analysis

Paul Juinn Bing Tan \*, Ming-Hung Hsu

National Penghu University of Science and Technology, Makung, TAIWAN

Received 10 April 2017 • Revised 24 December 2017 • Accepted 17 January 2018

### ABSTRACT

This paper discusses an English evaluation and teaching system consisting of several parts. The first part is a database comprising numerous subdatabases, which store login data and various levels of test questions of different levels. The second part is an arithmetic processing unit with a login module that produces a login interface to receive users' accounts and passwords. The login module is electronically connected to the database system so that the module can verify the input accounts and passwords with the login data stored in the database. The unit also randomly selects questions from different levels to form evaluation sets and generates an evaluation interface. In addition, the device features an input unit for inputting instructions and a display unit to display interfaces during use. Knowledge innovation and management accelerates with the prevalence of online assessment and learning because it has no difficulties in breaking through the limits of both space and time. Previous studies developing English evaluation and teaching device systems have rarely been researched from the dual perspective of developing the information technology system and learning and teaching language. Utilising the technology acceptance model as our fundamental theory to design the use of learning system is a must for the English e-learners.

**Keywords:** technology acceptance model, online learning behaviour, computer-assisted language learning, learning management system, artificial intelligence, semantics, cognitive science

### INTRODUCTION

Most English-learning websites provide self-learning, online teaching, and adult education services. Although common English-testing websites provide tests, they could be considerably improved. Currently, tests in many online testing systems have fixed questions. They appear to differ only because of the random order in which the questions are organised, rather than because questions are selected or organised according to the needs of users. In other words, test levels and difficulties cannot be customised according to the needs of users. To address this problem, our device offers an effective alternative. (Tan, 2013a; Tan, 2013b; Tan, 2015; Tan & Hsu, 2017a). Standardised testing mainly involves group tests. Depending on their compilation and design, these tests can be used to evaluate aspects such as achievements, interests, and capabilities. Test items are revised in accordance with test objectives and project preparations. Effective testing requires an emphasis on reliability and validity (Retrieved from <http://edglossary.org/standardisedtest/>). Various computer-based grading models have been created as a substitute to manual grading and have become a product for research and development. Although such systems are at the initial stage, an increasing number of people are joining the debates regarding the issue of digitalisation. Consideration must be given to the costs, markets, functions, innovative technologies, customer needs, marketing channels, quality, and sustainability of digital products. Designers of digital products must integrate the given company's internal ideas and the ideas of different customers in order to strengthen the technological capability of a digital product's innovative aesthetic design, assist in design-related problem solving, and provide an optimal blueprint for the digital product. Furthermore, research on the product's structure and an evaluation of its system development costs are required. With regard to digital product design, stable design methods and optimal

#### Contribution of this paper to the literature

- Provides a better learning system for language courses.
- System designers can perform knowledge management functions and fulfill interface requirements for students, thus enabling them to operate these systems.
- Examines the efficiency of e-learning and e-assessment systems from different perspectives, such as system development and web-design quality.

platforms for digital product design must be utilized under optimal resource allocation limitations. Furthermore, artificial intelligence technologies should be used to achieve optimal customisation. The optimal design of a digital product may be achieved by using the function of three-dimensional diagrams. The challenges faced by innovative digital products must be identified by looking at market and corporate business trends in markets where digital products are sold. With respect to digital product design, market strategies must be determined and market competition strategies and channel arrangements must be formulated. Costs and profits related to digital products must be effectively controlled in order to prevent or reduce losses and achieve innovation. As such, a company will play an important role in digital product models, colours, materials, service quality, and overall aesthetics. Each company seeks to increase aesthetic appreciation in its customers in order to improve its competitiveness (Tan & Hsu, 2017b).

### DESIGN OF UTILITY MODEL CONTENT

This system is an English evaluation and teaching device that enables administrators and users to log in and complete tests. The database includes tests with various levels of difficulty, the questions for which are randomly drawn from the different levels; administrators or users can also alter the difficulty level of tests.

To achieve its teaching and evaluation objective, this system consists of the following parts:

- (1) A database comprising numerous sub databases that store login data and test questions.
- (2) An arithmetic processing unit with a login module that produces a login interface to receive users' accounts and passwords. The login module is electronically connected with the database system to verify input accounts and passwords with the login data stored in the database. The unit also randomly selects test questions from different levels to form evaluation sets and generates an evaluation interface.
- (3) An input unit electronically connected to the arithmetic processing unit that enables users to input instructions.
- (4) A display unit electronically connected to the arithmetic processing unit that displays interfaces during use.
- (5) A notification interface, which is generated when the accounts and passwords received by the login module do not match with those stored in the database system.
- (6) An administrator's interface that is generated when the account and password of an administrator are entered.

The overall structure and specifications should be determined in digital product design, based on which the overall system layout is defined. Thus, digital product design is important as it involves the butterfly effect: if a digital product's design lacks a production concept, large expenses will be needed in the production process to regulate and replace equipment, materials, and labour. In contrast, the good design of a digital product is reflected not only in functional advantages but also in its ease of manufacture and low production costs, which increase the product's sustainability and competitiveness. Many leading companies in the digital product market emphasise digital product design and aim to design digital products with low fabrication costs and unique functions.

### Digital Product Research and Development Framework

Digital product research and development aims at innovative design and requires the integration of digital product design technologies and users, understanding of trends in the service industry and technological developments, user earned value management, coordination of internal and external resources, and construction of the product organisational framework. Thus, creation of the optimal value of digital products and customers must be considered in enterprise transformation.

### SYSTEM INSTALLATION METHOD

Clients can acquire a profound understanding of the objective and benefits of this system from the illustrations provided in the figures. **Figure 1** presents a schematic outline of the system. The system has a database (1) that is



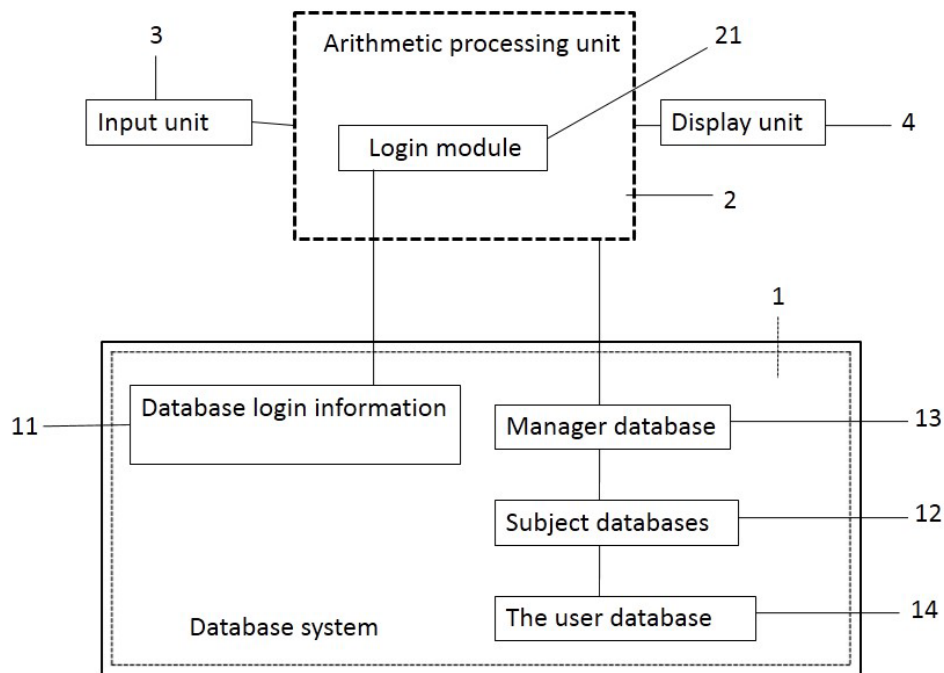


Figure 1. Outline of the proposed English evaluation and teaching device

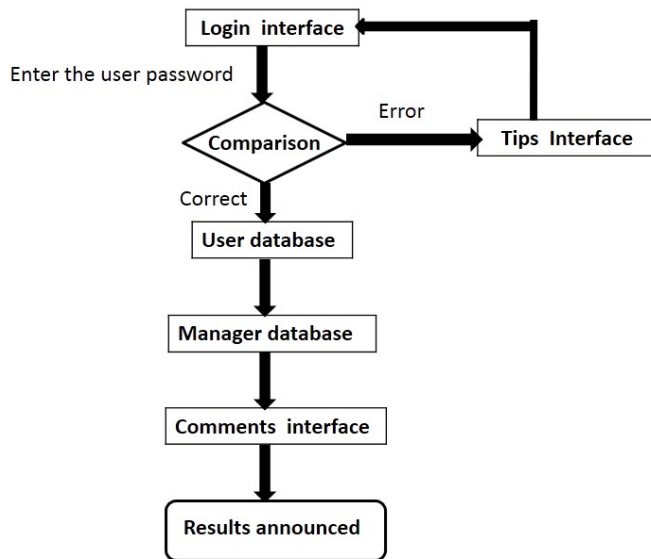


Figure 2. Evaluation procedures initiated by the system when a general user is logged in

divided into numerous subdatabases including a login database that stores login data (11) and a test question database (12) that stores test questions. The login database stores all the login accounts (e.g., student number or identification number) and passwords of users and administrators. The questions in the database are classified into advanced, intermediate, and basic levels.

The system also has an arithmetic processing unit (2) with a login module (21) that produces a login interface to receive the accounts and passwords of users. This unit is electronically connected to an input unit (3) and a display unit (4). The input unit (e.g., a keyboard or mouse) enables commands, such as accounts and passwords, to be entered, and the display unit (e.g., computer monitor) presents interfaces during use. In addition, the login module (21) is electronically connected to the database (1). As shown in Figure 2, this electronic connection enables the module to verify the input accounts and passwords with the login data stored in the database. If the verification result is valid, the system proceeds to the next step; by contrast, if the login account does not exist or the password is invalid, a notification interface is generated to notify the user of such errors, and the user is redirected to the login interface to reenter the account and password.

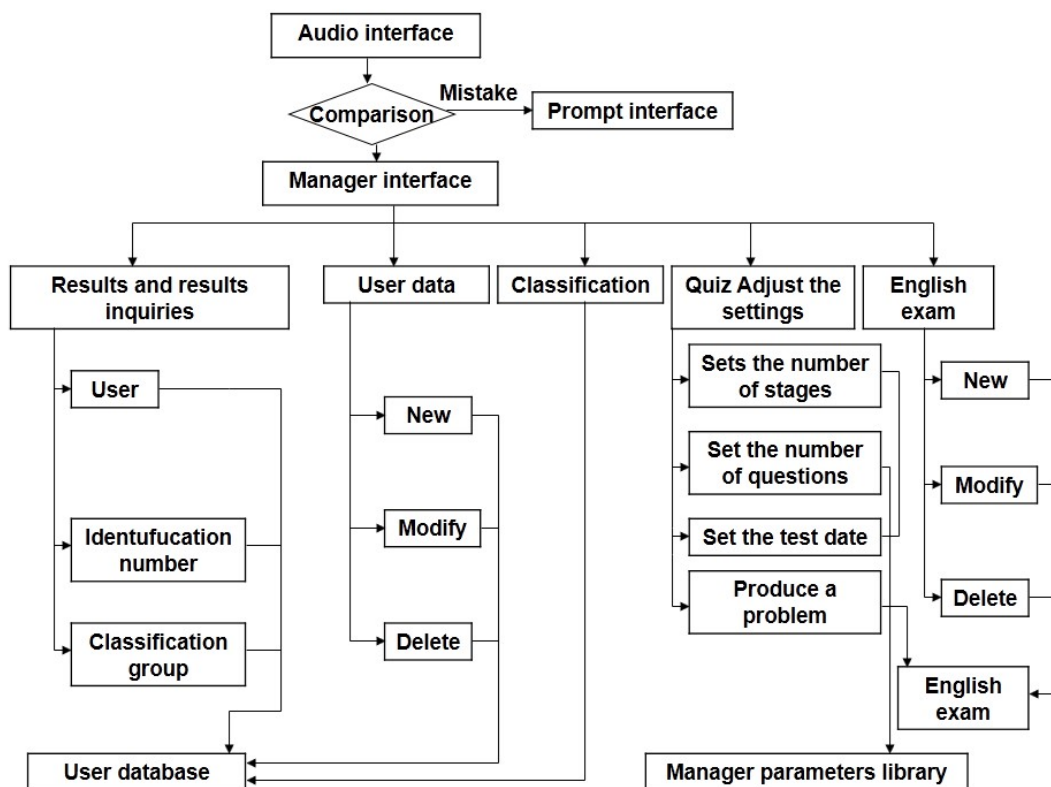


Figure 3. Overview of the administrator interface after the account and password are verified

Finally, Figure 3 depicts how the login module generates an administrator interface after the administrator enters his or her account and password in the login interface and they are verified as valid. The administrator can then modify parameters in the system as follows:

- (1) Add, edit, or delete data in the login data database.
- (2) Add, edit, or delete data in the test question database.
- (3) Search evaluation results according to the class, department, college, school, or person.
- (4) Modify the settings of evaluations, such as randomly generating tests for different student groups or modifying the time of evaluations, method of selecting questions for different levels, or number of levels.
- (5) Group students into levels according to the settings and levels.

The updated parameters are subsequently stored in the administrator’s parameter database (13) in the database system (1) (Figure 1).

Figure 2 indicates that when a general user, not including the administrator, is logged in, the system initiates evaluation procedures. The arithmetic processing unit randomly selects questions of different difficulty levels from the test question database (12) to form evaluation sets, and an evaluation interface is generated for the user to answer the questions through the input unit (3). An administrator can change the percentage of questions that are selected from the different difficulty levels by modifying the parameters. In the evaluation interface, users select and submit answers within the set evaluation time, after which their scores are calculated and announced by the arithmetic processing unit (2); questions that users have not answered are scored 0. Finally, the results are transmitted to the student database (14) in the database system (1).

As indicated by the aforementioned discussion, the English evaluation system is easy to operate. Moreover, because the questions can be varied according to the level of difficulty, the evaluation results have validity and credibility and can precisely differentiate students’ knowledge levels (Table 1). By using this system, students can be properly grouped according to their level of academic performance and be enrolled in courses suitable to their needs. Overall, this system can enhance the student learning.

**Table 1.** Basic Characteristics (Tan, 2013a; Tan, 2013b; Tan, 2015)

<b>Characteristics</b>	<b>Traditional classroom learning</b>	<b>E-learning</b>	<b>5W1H</b>
Location and time limits	Place and time dependent Physical evidence is limited	Can take place anywhere and at anytime Free	When and Where
Teaching and learning content	Teacher-centred	Learner-centred	Who
Personalisation	Push method One learning path (lowest common denominator)	Pull method Learning pace and path determined by learner	How and Which
Learning methods	Inflexible	Flexible	What

## ENGLISH E-LEARNING FOR COMPUTER-AIDED LANGUAGE LEARNING IN THE GLOBAL COMMUNITY

English has become the universal language for communicating on an international scale. With the growing numbers of foreign students enrolling in U.S. universities and colleges, several higher-education English as a second language (ESL) learning programmes have been developed. Many of these programmes use learning management systems (LMSs) as their computer-aided language learning tool to design e-learning courses. Liu (2013) suggested that this learning community deserves more attention because it contributes to U.S. academic practices. Irrespective of whether it is for academic research, pedagogical practice, or navigating in everyday life, it is crucial to understand the adaptability of other countries and help students succeed in their learning activities. English is currently the primary language for communication at many international conferences and is closely related to most programming languages, which ensures the widespread use of the language within various global communities.

### Learning Management System (LMS) Designing

LMS is a high-level strategic solution applicable to the planning, submission, and management of learning activities in organisations. LMS includes online, virtual classroom, and teacher-guided learning. The solution involves system evaluation and improvement of the overall organisation's abilities and performance and presents an alternative to isolated and scattered learning. LMS focuses on management learners and tracks their progress and performance in all types of training activities. It is used for serious management tasks, such as human resource and ERP system reporting. However, it is not applied to the building of course content.

## EDUCATIONAL PROGRAMMES OF ENGLISH LEARNING IN TAIWAN

English is a compulsory course for elementary, middle, and junior high school students in Taiwan. College students also usually need to achieve a certain level of English proficiency to get a well-paying job, because Taiwanese universities often use original-copy English textbooks in their classes. However, English is not only a required course for students, but an important international language; as Huang (2005) pointed out, 'English skills are a major factor in the educational success of Taiwanese students, and programmes are provided to prepare students for future career prospects. Thus, more and more young learners are receiving ESL lessons in school.'

### Learning Content Management System (LCMS) Designing

LCMS focuses on learning content. It helps authors, educational designers, and subject experts more effectively develop e-learning content. The main business problem solved by LCMS is the timely development of sufficient content, which aims to satisfy individual and group learners' needs. LCMS features include the utilization of learning objects to form the system's basic framework, the availability of all learning content in a database, and the ability to reuse and restructure learning content in various ways (Tan & Hsu, 2017ab).

## DESIGNING SYSTEMS AND TOOLS FOR ENGLISH E-LEARNING AND ONLINE ASSESSMENT

Currently, there are various methods and tools geared towards ESL learning, which are generally divided into two types: traditional learning and e-learning. In traditional approaches, students have their own space in a classroom, where they learn English from teachers and textbooks within a set time. Students can only receive the information from their teacher and cannot receive any additional information they require. By contrast, in e-

**Table 2.** Disadvantages and Advantages of Traditional and E-learning Approaches (Zhang et al, 2004; Tan, 2013a; Tan, 2013b; Tan, 2015)

	<b>Traditional approaches</b>	<b>E-learning approaches</b>
Advantages	<ul style="list-style-type: none"> <li>⊙ Familiar to both teachers and students</li> <li>⊙ Direct feedback</li> <li>⊙ Cultivation of a social community</li> <li>⊙ Motivates users</li> </ul>	<ul style="list-style-type: none"> <li>⊙ User-centred and self-paced</li> <li>⊙ Place- and time-flexible</li> <li>⊙ Potentially provided to universal learners</li> <li>⊙ Cost-effective for users</li> <li>⊙ Archival ability for information resharing and reusing</li> </ul>
Disadvantages	<ul style="list-style-type: none"> <li>⊙ Teacher-centred</li> <li>⊙ Place- and time-limited</li> <li>⊙ More expensive (learner resources and teacher wages)</li> </ul>	<ul style="list-style-type: none"> <li>⊙ Lack of immediate direct feedback in a synchronous learning environment</li> <li>⊙ Uncomfortable for some users</li> <li>⊙ Can be expensive (hardware system)</li> <li>⊙ Potentially more confusion, frustration, and anxiety</li> <li>⊙ Increased preparation time required by learners</li> </ul>

learning approaches, students can learn from teachers or computers to receive more information immediately. There are also no time constraints in e-learning situations, and students do not even need a teacher. Furthermore, students can learn English by themselves because language e-learning systems provide whatever information they need. **Table 1** presents an overview of the main differences between the traditional and e-learning methods.

With the advent of English e-learning technology over the past decade, accessibility to training, teaching, and learning has increased substantially. The challenge currently encountered by education enterprises is attracting students to their English e-learning services. In this study, we developed a technical system to help clarify learners' intentions and their continued desire to use the system in order to assist them with English e-learning and online assessment.

As indicated in **Table 1**, e-learning and traditional approaches offer different learning methods. For example, in traditional approaches, students only learn from their teachers and cannot access the newest information immediately. However, in e-learning approaches, students use a computer to learn English and can search the Internet to efficiently obtain other information not provided by the programme (**Table 1**). The disadvantages and advantages of the e-learning and traditional approaches are listed in **Table 2**.

## ENGLISH LEARNERS IN TAIWAN

In Taiwan, English is viewed as a key language that connects the Taiwanese with the rest of the world. In particular, English has an important role in Taiwan's economy because it is vital for success in the financial and technology sectors. Technology in our lives that is the case, we can solve a lot of problems through this method (Joiner, 1981). In a study on applied linguistics, Krashen, Long, and Scarcella (1979) pointed out that younger learners can learn languages more effectively. Thus, Taiwanese English learners begin as children and learn English through various avenues, including online learning sites, language schools, and talking with foreigners in person. Although some debates and questions about English learning in Taiwan remain, it is undeniable that learning English is a critical and effective way for Taiwan to establish a foothold in international communities.

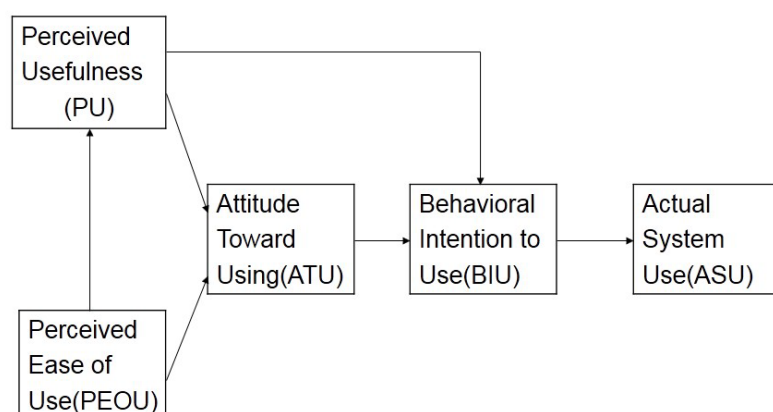
## ENGLISH LEARNERS IN MALAYSIA

Teo, Wong, Thammetar, and Chattiwat (2011) studied the self-reported intentions of 245 Malaysian teachers and students' intention to use (ITU) computer behaviour, and they found that perceived usefulness (PU) of computer technology, perceived ease of use (PEOU), and attitudes towards computer use were essential determinants of teachers' and students' ITU. Furthermore, their research confirmed that the technology acceptance model (TAM) is suitable for predicting the technical acceptance among students and teachers; overall, technology was well-accepted by the studied population in Malaysia.

## E-LEARNING AND E-ASSESSMENT

E-learning is changing the way education is conducted and is recognised as the most convenient and effective method for learning. Thus, educational institutions have begun to realise that e-learning can help them enhance their teaching; moreover, the benefits of an effective education strategy can outweigh its costs (Urduan, 2000).

Some previous studies on learner acceptance of LMSs have been conducted using the unified theory of acceptance and use of technology (UTAUT) model. For example, Yoo, Han, and Huang (2012) found that employers in South Korea were positively influenced by factors such as effort expectancy and attitude towards e-learning in



**Figure 4.** Technology acceptance model (TAM) (Davis, 1986; Davis, 1989a; Davis et al, 1989b; Venkatesh et al, 2003)

the workplace. Additionally, Chiu and Wang (2008) confirmed that performance expectancy, effort expectancy, and positive subjective task value can lead to the success of college students who take web-based courses.

Regardless of the benefits, some users change their learning attitude towards e-learning during their learning procedures and activities if the results are not what they expected. E-learning typically requires more self-motivation, and learners who work alone can easily become frustrated. Thus, previous studies have indicated that designers and researchers should regularly check for any inconveniences or system errors and fix them quickly to provide a better e-learning environment for their users.

Most e-learning systems provides services for searching, downloading, and delivering content (Tan, 2013a; Tan, 2013b; Tan, 2017a). They also provide e-users with various learning tools, such as systems, e-books, audio files, e-content, and videos to enhance their teaching and learning performance.

### Differences between LMS and LCMS Development

Both tools allow for the management and tracking of content with regard to learning objects. However, LMS can manage and track fused curriculums that combine online content, classroom activities, virtual classroom meetings, and other sources. Although LCMS does not manage fused learning, it manages content at a lower intensity level compared to that used for learning objects, which in turn allows for the reorganization and reuse of online content. Furthermore, high-level LCMS can dynamically create learning objects based on user configuration files and learning styles. If both systems follow XML standards, information can be easily transmitted from the object level to the LMS level (Greenberg, 2013).

### ADOPTION THEORIES TO DEVELOP A SYSTEM

For the past decade, scholars and practitioners have explored people's interest in new technologies and have tried to predict or affect their likely use. Overall, their finding demonstrate that intention positively influences e-learning acceptance (Chen, 2011; Liao & Lu, 2008; Padilla-Meléndez, Garrido-Moreno, & Del Aguila-Obra, 2008; Tan, 2013a; Tan, 2013b; Tan, 2015; Toral, Barrero, & Martínez-Torres, 2007). As Davis (1986, 1989) and Davis, Bagozzi, and Warshaw (1989) noted, 'A wide body of research focuses on identifying factors affecting people's intentions to use new technologies and how these intentions predict actual usage (Figure 4).'

The TAM was developed from another psychological construct, the theory of reasoned action (TRA) (Urdan, 2000), which was developed by Davis (1986). The TAM comprises two main factors, PU and PEOU, which are believed to positively affect attitudes towards using and subsequently positively affect behavioural ITU and actual system use (Tan, 2013a; Tan, 2013b; Tan, 2015; Chen, 2011).

### PREVIOUS STUDIES

Adopting the concept of IS (information system) acceptance to identify behavioural determinants is useful for designing and implementing the guiding systems of theoretical models. The TAM posits that IS acceptance is primarily determined by two systemic beliefs: PEOU and PU (Davis, 1986, 1989; Davis et al, 1989).

**Table 3.** Review of Previous Studies (Tan, 2013a; Tan, 2013b; Tan, 2015)

Author(s)	Theory	Major Findings
Fishbein and Ajzen (1975)	TAM, TRA	TAM is a psychological theory that explains how an individual's action is decided by his or her BI to perform and assumes the strength of the TRA.
Davis (1989a)	TAM	TAM has been adopted in various studies to examine the user acceptance of information technology.
Taylor and Todd (1995)	TAM, TPB	The role of prior experience, as well as combined social influences and behavioural control, were investigated using the TAM.
Agarwal and Prasad (1997)	IDT, TAM	TAM and IDT were used to examine the behaviours of pre- and post-adoption attitudes towards information technology.
Venkatesh and Davis (2000)	TAM	Utilising a particular system can help with job performance. The degree to which a person strongly believes
Venkatesh et al. (2003)	TAM, TRA	From the current specification, the TAM was simplified by changing the attitude structure found in the TRA.
Wixom and Todd (2005)	TAM	The antecedents and moderators of PU and PEOU and additional or alternative belief elements were examined. The TAM was expanded by introducing elements from related models.
Liaw et al. (2007)	TAM	The basic guidelines for expanding e-learning systems and environments were described, and instructors' and learners' attitudes towards e-learning methods were examined.
King and He (2006)	TAM	Meta-analysis as a rigorous alternative to narrative and qualitative literature reviews was explored. In total, 88 published studies and learners as surrogates for professionals in the TAM studies were reviewed.
Lee (2006)	TAM	The effects of e-content quality and e-course attributes on PU were found to be significant and significantly negative, respectively. In addition, computer self-efficacy was shown to have a significant influence on PEOU.
Polančič et al. (2010)	TAM	The successful use of frameworks was found to be dependent on two major factors: the PU of the framework and a continued ITU.
Tan (2013a)	TAM, UTAUT	English e-learning websites can help users increase their knowledge and are easy to use; however, system designers should continue to work to improve these sites.
Tan (2013b)	TAM, UTAUT	Four core constructs have a significantly positive influence on behavioural intention. E-placement tests are more appreciated by the students and are more likely to be used by them. Furthermore, administrators intending to encourage e-placement tests in their schools should include such constructs in the placement testing implementation.
Lakhal et al. (2013)	TAM, UTAUT	The suggestions proposed at the BIU desktop video conference focused on the factors most critical for administrators and faculties in higher education to consider when they implement academic online courses.
Tan (2015)	TAM	System designer must focus on e-users' demands when developing e-learning and online assessment systems. If LMSs are provided for e-users and meet the criteria for pragmatic learning purposes, such provisions can help maintain and enhance e-users' satisfaction and loyalty.
Tan & Hsu (2017a)	PZB & TAM	Digital products must be manufactured based on consumer demands and satisfactions for fast and high quality products, and digital product designers must incorporate ideas from different consumers.

## MOTIVATION FOR DEVELOPING A NEW SYSTEM

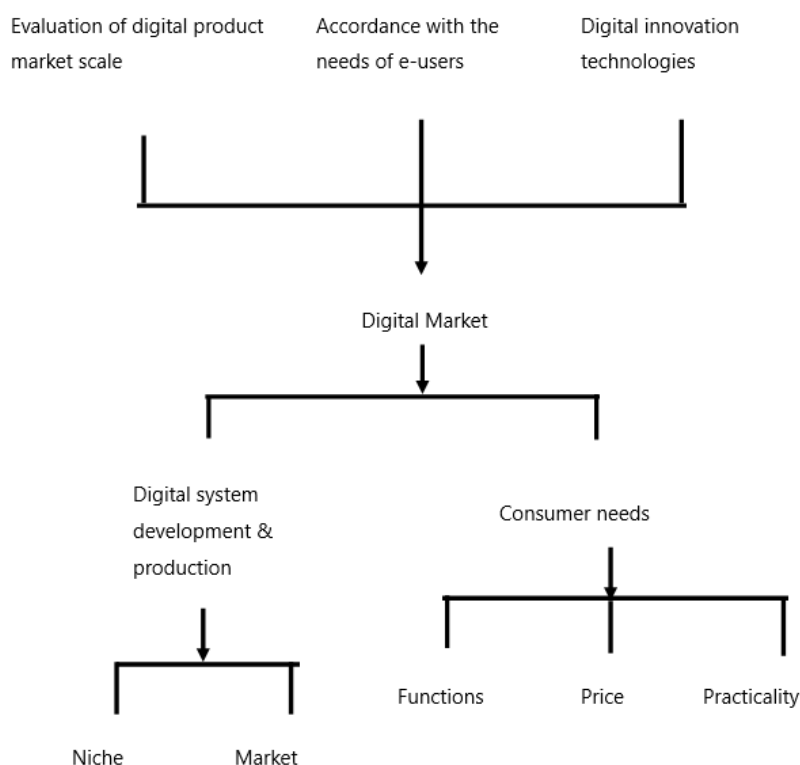
English is not an official language in Taiwan, and in the past, it was not widely spoken in the country. However, because of globalisation, the Taiwanese have begun to learn English and speak with people from other countries. English is one of the most used languages in the world, and it has many learners. Considering the global importance of English, we aimed to create a system that would help the e-learners who prefer to learn through online techniques. We expect that entrepreneurs will appreciate an assessment of learners' interest in e-learning, because understanding the factors that affect their attitudes and behaviours is key to creating a high-quality and satisfactory system; it is crucial to design new learning technologies for e-users (Table 3).

## PURPOSES OF THE DESIGN

This study examined English learners' attitudes towards English evaluation and teaching devices. The system developed herein quantifies people's perception, intentions, and attitudes towards the use of e-learning technologies to verify the significance of PU and PEOU when people decide to utilise a new system. We contend that appreciating the factors that influence people's use of new technologies will help improve these technologies.

The specific purposes of this study were:





**Figure 5.** Digital system product (e-content) research and development procedure

1. To understand the value of a newly developed system and the reasons learners decide to continue using a particular tool.
2. To understand the types of skills e-learners want to obtain from a learning system.
3. To understand the attitudes of learners towards a system.
4. To design a system that can assist e-learners with obtaining improved learning results.
5. To judge if a system is likely to play a substantial role in e-learners knowledge development.
6. To determine the factors that influence e-learners' intentions and behaviours to utilise systems as the primary learning resources.

### IMPLICATIONS FOR PRACTICE IN INDUSTRIES

E-learning systems must address e-users' demands; responding to their concerns and feedback is useful for maintaining and enhancing the e-users' loyalty towards particular English e-learning LMS systems. Moreover, if PU does not significantly correlate with attitudes towards usage, it can appear that the informative nature of the systems has no effect on learners' usage attitudes. In other words, PU was significantly correlated with both PEOU and attitudes towards usage, which can diminish the apparent impact of PU and may be more important for the PU. Furthermore, PU continues to have a significant impact on usage, regardless of its failure to affect attitudes. Thus, if systems designers want more e-users to use and feel satisfied with their system, they should work to improve the e-content quality. Quality is critical to the whole system, and studies have revealed that system designers should improve knowledge management functions and improve user interfaces to render them easier to operate (i.e., 'design the right systems, design the systems right') (Figure 5) (Tan, 2013a; Huang, 2005; Parasuraman, Zeithaml, & Berry, 1985).

### SERVICE QUALITY GAP MODEL

The quality revolution of the 1980s was not only limited to manufacturing but also influenced all organisations, services, and levels of government. Thus, the importance of quality management since then can be deduced (Niranjan & Metri, 2008). The first model had only a few key structures, and it was used to improve the basic competition for improving the quality, urging services, companies and their competitors could provide better services.

The service quality gap model (also known as the PZB model) was developed by Parasuraman et al. (1985). Quality is considered the highest priority for companies to meet the desired outcome of their services and is related to high expectations from clients. Parasuraman et al. (1985) identified 10 criteria to evaluate the initial quality of a service, which is defined as the difference between the expected and received service. The 10 criteria are as follows:

- (1) Understanding: making an effort to understand clients' needs
- (2) Reliability: offering dependable and reliable services
- (3) Responsiveness: being willing to provide services to clients
- (4) Tangibles: physical evidence of the service
- (5) Courtesy: providing consideration, respect, friendliness, and politeness to clients
- (6) Communication: listening and responding to clients' requests and feedback
- (7) Credibility: ensuring honesty, trustworthiness, and believability
- (8) Competence: having the knowledge and skills necessary to provide services
- (9) Access: ensuring ease of contact and approachability for clients
- (10) Security: ensuring that danger, doubt, and risk are minimised

Notably, these criteria include the five main dimensions for measuring, delivering, and anticipating a company's service: reliability, responsiveness, assurance, empathy, and tangibility. In this model, the client sets expectations according to their perceptions of a company's performance or behavioural decisions (Kang & James, 2004). These criteria and the PZB model were later applied to develop the SERVQUAL scale, which measures the discrepancy between received and expected service quality and is widely cited in the marketing literature (Brønn, 2012; Kang & James, 2004). Currently, both the PZB and SERVQUAL models are widely utilised in the industry.

## RECOMMENDATIONS FOR FUTURE DESIGN AND RESEARCH

Further research and system designs should widen the scope of the current study, which was designed focus on restricted to this particular system development field. Future studies and system designs can use the following suggestions:

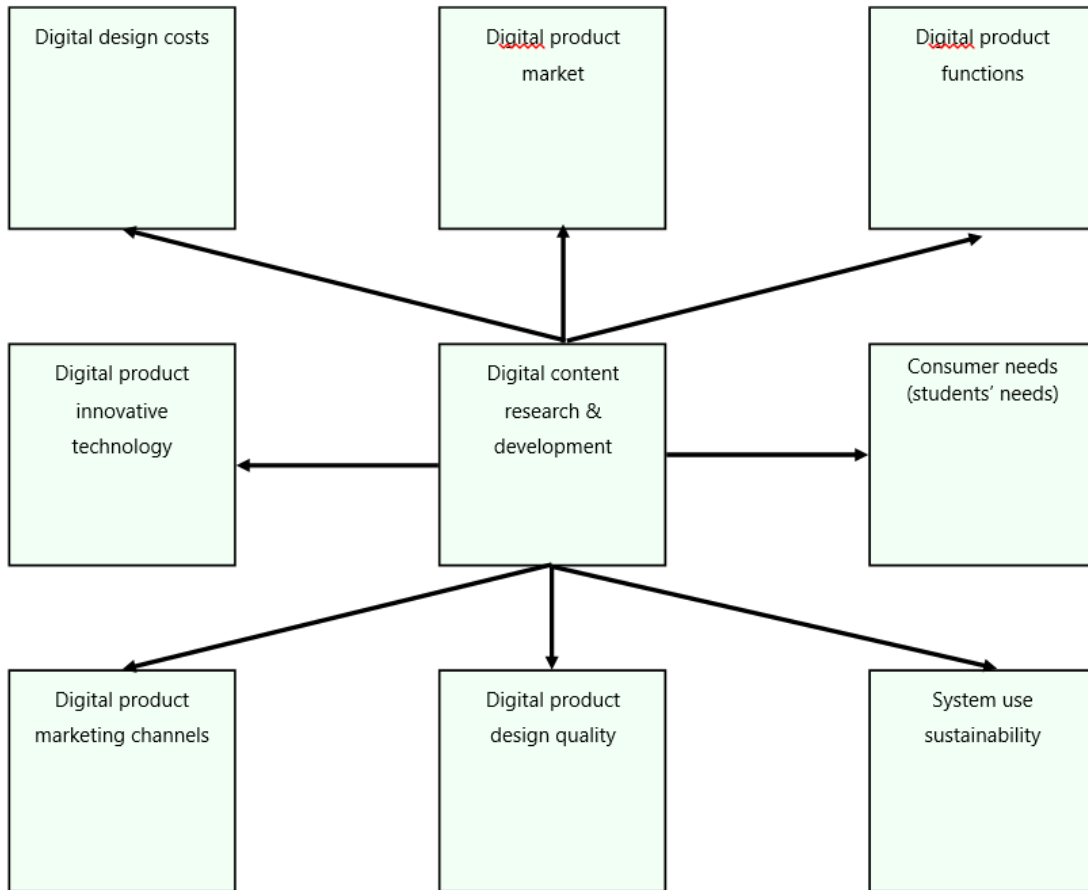
1. Collect data from domains other than language learning to increase external validity.
2. Examine the efficiency of e-learning and e-assessment systems from different perspectives, such as system development and web-design quality.
3. Test the system with participating e-learners from different locations.
4. Use the plan-do-check-act model to re-examine the quality of the system developed in the present study.
5. Use the PZB model to re-examine client satisfaction with the system developed in the present study.

## CONCLUSION

Design the right systems and design the systems right; do the right things and do the things right (**Figure 6**).

Digital product research and development:

- (1) Digital product designers must consider the company's internal ideas and the ideas of different customers.
- (2) Strengthen technological capability of the digital product's innovative aesthetic design, assist in design-related problem-solving, provide a comprehensive product blueprint.
- (3) Research on digital product structure and evaluation of design costs.
- (4) Steady design methods must be obtained through an optimal platform for digital product design under optimal resource allocation limitations (ERP concept).
- (5) Use artificial intelligence technologies to achieve optimal customization. Use the function of three-dimensional diagrams to achieve optimal digital product design.
- (6) Identify the challenges faced by innovative digital products by looking at market and corporate trends in markets where digital products are sold.
- (7) With respect to digital product design, market strategies must be determined and market competition strategies and channel arrangements must be formulated.
- (8) Costs and profits related to digital products must be effectively controlled in a reasonable manner in order to prevent or reduce losses, achieve innovation, and overcome business difficulties. As such, a company will play an important role in digital product models, colours, materials, service quality, and overall aesthetics. This will increase aesthetic appreciation in a company's customers and improve its competitiveness.



**Figure 6.** Digital product research and development processes

Digital products must be manufactured based on consumer demands and satisfactions for fast and high quality products, and digital product designers must incorporate ideas from different consumers. The technological capability of digital products’ creative and aesthetic design should be improved. Assistance must be given to digital product consumers in solving system issues, and comprehensive digital product design services must be provided (Figure 5 and Figure 6).

Knowledge management and basic concepts in digital product design include four essential factors:

- (1) Social and natural environment factors: Social factors include politics, culture, and religion. Natural environment factors include resources and energy and other materials obtained from nature.
- (2) Technological factors: Technological factors include energy, processing techniques, and functions. It can be said that these are the factors that most directly restrict the implementation of a design.
- (3) Aesthetic factors: Aesthetics-related solutions are multifaceted and include the object’s social environment, educational level, value system, personality, etc.
- (4) Human factors: Looking at the design history of digital system products, it can be seen that the genuine emergence of the “people-oriented” approach occurred only during the digital age. In the future, the development of digital design will focus more on the coordinated development of human, technological, and environmental elements.

The design of a digital product must consider all four types of factors so that the digital product meets the digital market demand and adapts to social development and production (Retrieved from MBALib wiki: <http://wiki.mbalib.com/zhtw/%E4%BA%A7%E5%93%81%E8%AE%BE%E8%AE%A1>).

A company’s overall digitalisation requires support from information technologies. It is necessary to determine whether one concept or system is applied (William & Michael, 2002), to establish the direction of digitalisation users, to define the knowledge management of product innovation, to use optimal purposes of the digital product, and to determine the product innovation’s basic knowledge and abilities.

## REFERENCES

- Agarwal, R., & Prasad, J. (1997). The role of innovation characteristics and perceived voluntariness in the acceptance of information technologies. *Decision sciences, 28*, 557-582.
- Chen, J.-L. (2011). The effects of education compatibility and technological expectancy on e-learning acceptance. *Computers & Education, 57*, 1501-1511.
- Chiu, C.-M., & Wang, E. T. (2008). Understanding Web-based learning continuance intention: The role of subjective task value. *Information & Management, 45*, 194-201.
- Davis, F. D. (1986). *A technology acceptance model for empirically testing new end-user information systems: Theory and results* (Doctoral Thesis). Massachusetts Institute of Technology, Cambridge, MA.
- Davis, F. D. (1989). Perceived usefulness, perceived ease of use, and user acceptance of information technology. *MIS quarterly, 319-340*.
- Davis, F. D., Bagozzi, R. P., & Warshaw, P. R. (1989). User acceptance of computer technology: a comparison of two theoretical models. *Management science, 35*, 982-1003.
- Fishbein, M., & Ajzen, I. (1975). *Belief, attitude, intention, and behavior: An introduction to theory and research*. Massachusetts, MA: Addison-Wesley.
- Greenberg, L. (2013). *LMS and LCMS: What's the Difference?* Retrieved from <https://www.efrontlearning.com/blog/2013/05/lms-and-lcms-whats-the-difference.html>
- Huang, S.-Y. (2005). Taiwanese students talk about English in Taiwan and their lives. *Languages, Communities, and Education, 45*.
- Joiner, E. G. (1981). The Older Foreign Language Learner: A Challenge for Colleges and Universities. *Language in Education: Theory and Practice, 34*, ERIC.
- Kang, G. D., & James, J. (2004). Service quality dimensions: an examination of Grönroos's service quality model. *Managing Service Quality: An International Journal, 14*(4), 266-277.
- King, W. R., & He, J. (2006). A meta-analysis of the technology acceptance model. *Information & management, 43*(6), 740-755.
- Krashen, S. D., Long, M. A., & Scarcella, R. C. (1979). Age, rate and eventual attainment in second language acquisition. *TESOL quarterly, 573-582*.
- Lakhal, S., Khechine, H., & Pascot, D. (2013). Student behavioural intentions to use desktop video conferencing in a distance course: integration of autonomy to the UTAUT model. *Journal of Computing in Higher Education, 25*, 93-121.
- Lee, Y. C. (2006). An empirical investigation into factors influencing the adoption of an e-learning system. *Online Information Review, 30*(5), 517-541.
- Liao, H.-L., & Lu, H.-P. (2008). The role of experience and innovation characteristics in the adoption and continued use of e-learning websites. *Computers & Education, 51*, 1405-1416.
- Liaw, S.-S., Huang, H.-M., & Chen, G.-D. (2007). Surveying instructor and learner attitudes toward e-learning. *Computers & Education, 49*, 1066-1080.
- Liu, J. (2013). *E-learning in English classroom: Investigating factors impacting on ESL (English as Second Language) college students' acceptance and use of the Modular Object-Oriented Dynamic Learning Environment (Moodle)* (Masters Thesis). Iowa State University, Iowa.
- Niranjan, T. T., & Metri, B. A. (2008). Client-vendor-end user triad: a service quality model for IS/ITES outsourcing. *Journal of Services Research, 8*(1), 123.
- Padilla-Meléndez, A., Garrido-Moreno, A., & Del Aguila-Obra, A. R. (2008). Factors affecting e-collaboration technology use among management students. *Computers & Education, 51*, 609-623.
- Parasuraman, A., Zeithaml, V. A., & Berry, L. L. (1985). A Conceptual Model of Service Quality and Its Implications for Future Research. *Journal of Marketing, 49*, 41-50.
- Polančič, G., Heričko, M., & Rozman, I. (2010). An empirical examination of application frameworks success based on technology acceptance model. *Journal of Systems and Software, 83*, 574-584.
- Product Design. (n.d.). Retrieved from MBALib wiki: <http://wiki.mbalib.com/zh-tw/%E4%BA%A7%E5%93%81%E8%AE%BE%E8%AE%A1>
- Simcic Brønn, P. (2012). Adapting the PZB service quality model to reputation risk analysis and the implications for CSR communication. *Journal of Communication Management, 16*(1), 77-94.

- Standardized test. (n.d.). In *The Glossary of Education Reform*. Retrieved from <http://edglossary.org/standardised-test/>
- Tan, P. J. B. (2013a). Applying the UTAUT to understand factors affecting the use of English e-learning websites in Taiwan. *Sage Open*, 3, 1-12.
- Tan, P. J. B. (2013b). Students' adoptions and attitudes towards electronic placement tests: A UTAUT analysis. *American Journal of Computer Technology and Application*, 1, 14-23.
- Tan, P. J. B. (2015). English e-learning in the virtual classroom and the factors that influence ESL (English as a Second Language): Taiwanese citizens' acceptance and use of the Modular Object-Oriented Dynamic Learning Environment. *Social Science Information*, 211-228.
- Tan, P. J. B., & Hsu, M.-H. (2017a). Understanding the needs and criteria of employees in the electronics industry for English e-learning website programmes. *2017 International Conference on Industrial Informatics & Computational Intelligence*, Cambodia.
- Tan, P. J. B., & Hsu, M.-H. (2017b). Developing a system for English evaluation and teaching devices. *2017 International Conference on Applied System Innovation (ICASI)*, Sapporo, 938-941. <https://doi.org/10.1109/ICASI.2017.7988596>
- Taylor, S., & Todd, P. (1995). Assessing IT usage: The role of prior experience. *MIS quarterly*, 561-570.
- Teo, T., Wong, S. L., Thammetar, T., & Chattiwat, W. (2011). Assessing e-learning acceptance by university students in Thailand. *Australasian Journal of Educational Technology*, 27(8), 1356-1368.
- Toral, S., Barrero, F., & Martínez-Torres, M. d. R. (2007). Analysis of utility and use of a web-based tool for digital signal processing teaching by means of a technological acceptance model. *Computers & Education*, 49, 957-975.
- Urduan, T. A. (2000). *Corporate e-Learning: Exploring a new frontier*. San Francisco, CA: W.R. Hambrecht.
- Venkatesh, V., & Davis, F. D. (2000). A theoretical extension of the technology acceptance model: Four longitudinal field studies. *Management science*, 46(2), 186-204.
- Venkatesh, V., Morris, M. G., Davis, G. B., & Davis, F. D. (2003). User acceptance of information technology: Toward a unified view. *MIS Quarterly*, 27(3), 425-478.
- William, K. K., & Michael, J. S. (2002). Psychophysical assessments of image-sensor fused imagery. *Publish Information*, 44(2), 257.
- Wixom, B. H., & Todd, P. A. (2005). A theoretical integration of user satisfaction and technology acceptance. *Information systems research*, 16(1), 85-102.
- Yoo, S. J., Han, S.-h., & Huang, W. (2012). The roles of intrinsic motivators and extrinsic motivators in promoting e-learning in the workplace: A case from South Korea. *Computers in Human Behavior*, 28, 942-950.
- Zhang, D., Zhao, J. L., Zhou, L. & Nunamaker, J. F. (2004). Can e-learning replace classroom learning? *Communications of the ACM*, 47(5), 75-79.

<http://www.ejmste.com>



<http://www.ejmste.com>



<https://twitter.com/ejmste>



<https://www.facebook.com/ejmste>



<http://modestum.co.uk/>



[publications@modestum.co.uk](mailto:publications@modestum.co.uk)



# Improving the Basics of GIS Students' Specialism by Means of Application of ESDA Method

Shiliang Zhang <sup>1\*</sup>, Dejing Lin <sup>2</sup>, Tingcheng Chang <sup>1</sup>

<sup>1</sup> School of Information and Electrical Engineering, Ningde Normal University, Jiaocheng District, Ningde, CHINA

<sup>2</sup> United Network Communications Co., Ltd., Fuzhou, CHINA

Received 24 October 2017 • Revised 21 February 2018 • Accepted 28 February 2018

## ABSTRACT

University education should highlight the cultivation of students' capability to make them qualified for meeting the social market requirements. University students, who major in GIS, in addition to abilities and qualities equipped generally, are supposed to have abilities in GIS basic theory and cutting-edge technologies, GIS software operation and data collection and processing, spatial data modeling and analysis, independent learning as well as GIS scientific research and innovation. The paper takes the spatial analysis of Fujian telecommunications consumption data as the example, attempts a new perspective that introduces ESDA, an analytic method, into the research of telecommunications consumption, thus combining perceptual and conceptual knowledge, qualitative and quantitative analysis, so as to not only improve the competency of GIS majors, but also cultivate their spatial analysis capability, develop favorable thinking mode, therefore laying a solid basis for their future study and work.

**Keywords:** students' specialism, ESDA, communication expenditure, scatter plot

## INTRODUCTION

According to the needs of subject penetration and practical teaching, teachers of various disciplines in modern colleges and universities should constantly enrich their own theoretical knowledge and teaching methods of data analysis. Through the effective development of permeation teaching, the theory and method of data analysis are implemented in the teaching and practical activities of various subjects. Through the training concept of data analysis ability which runs through the whole process of teaching, students can gradually improve their own ability of data analysis and cultivate the systematic thinking mode of data analysis, and promote the improvement of students' comprehensive quality and professional competitiveness in the four years of studying and living in the university. This paper takes Fujian communication consumption data analysis as an example, uses spatial autocorrelation analysis method from county scale, as well as explores relationship between spatial differentiation law of communication consumption and economic development. This not only makes GIS students' master basic knowledge of spatial autocorrelation, but also cultivate their spatial analysis ability, form a good mode of thinking, and lay a solid foundation for future study and work.

In some cases, spatial autocorrelation is a special and very effective technique that can effectively answer questions, such as spatial distribution of phenomena. Around 1950, Moran's spatial analysis based on biological phenomena extended correlation coefficient of one-dimensional spatial concept to two-dimensional space, thus defining Moran exponent (Moran, 1950). Shortly thereafter, Geary proposed concept of Geary coefficient, analogous to Durbin-Watson statistics of regression analysis (Geary, 1954). After decades, through efforts of vast number of geologists, especially related work of Cliff and Ord, spatial autocorrelation has gradually developed into one of important topics in geospatial analysis. Another prominent theme is Wilson's spatial interaction theory and model. On basis of Moran exponent and Geary coefficient, Anselin developed a local analysis method of spatial autocorrelation. Getis et al. proposed a spatial relation index based on distance statistics (Getis & Ord, 1992). In particular, creation of Moran scatter plot analysis method represents a significant progress in spatial autocorrelation analysis. In China, research papers and works on spatial autocorrelation are in ascendant, covering

**Contribution of this paper to the literature**

- The main contribution of this paper to the literature is related to how the level of economic development influences training/support the respondents' willingness to expend the money during the telecom communication.
- The special issue shows the need for diverse research approaches. The broad range of research foci for statistical methods of fostering the mathematics learning, under a classroom learning perspective, and under a professional development perspective, goes hand in hand with a broad range of approaches.

theories, methods and techniques with more practice and application (Tobler, 2014). The rest of the paper is organized as follows: In section 2, we introduce research methods, global autocorrelation, and the local autocorrelation. The Data sources and preprocessing are shown in section 3. Section 4 describes the analysis of the case. Finally, conclusions are presented in section 5.

## RESEARCH METHODS

### Exploratory Spatial Data Analysis (ESDA)

Following Anselin (1998), ESDA (exploratory spatial data analysis) is a collection of techniques to describe and visualize spatial distributions (Anselin, 1999; Anselin, Sridharan, & Gholston, 2007); identify atypical locations or spatial outliers; discover patterns of spatial association, clusters or hot-spots; and suggest spatial regimes or other forms of spatial heterogeneity. Central to this conceptualization is the notion of spatial autocorrelation or spatial association, i.e., the phenomenon where locational similarity (observations in spatial proximity) is matched by value similarity (attribute correlation). True ESDA pays attention to both spatial and attribute association. ESDA is a subset of EDA (exploratory data analysis) methods that focus on the distinguishing characteristics of geographical data, specifically, on spatial autocorrelation and spatial heterogeneity. Exploratory Data Analysis graphical and visual methods are used to identify data properties for purposes of pattern detection in data. ESDA techniques can help detect spatial patterns in data, lead to the formulation of hypotheses based on the geography of the data, and in assessing spatial models. ESDA requires that numerical and graphical procedures be linked with a map.

ESDA is focuses on the description and interpretation of the spatial relationships of regionalized variables, particularly spatial autocorrelation and spatial heterogeneity. ESDA is also used to describe and visualize spatial distributions, identify atypical locations or spatial outliers, discover patterns of spatial association and suggest all types of spatial heterogeneity. ESDA analysis include the construction of spatial weight matrix, scatterplot, global spatial autocorrelation measure, and local spatial correlation identification.

### Global Autocorrelation

SA (spatial autocorrelation) studies the potential interdependence of variables among observational data in the same distribution area (Yang & Wong, 2013; Zhang et al., 2011), which aims to study whether the communication consumption expenditure of the county area covered by 9 cities in Fujian province will be affected by neighboring regions. Firstly, the study calculates the global and local indexes of the spatial autocorrelation of the communication consumption expenditure, and the global index is used to detect the relation of the spatial distribution state of the whole consumption, that is, to use Moran's I to reflect the autocorrelation degree of the region, and also uses the local Moran's I to adopt local indicators from the unit part, thereby determining the degree of relevance of consumption of each space unit and adjacent units. If the approximate region is close to the value, then the spatial autocorrelation is strong, conversely, the spatial autocorrelation is weak. The formula is:

$$I = \frac{N \sum_i \sum_j w_{ij} (X_i - \bar{X})(X_j - \bar{X})}{\sum_i \sum_j w_{ij} \sum_i (X_i - \bar{X})^2} \quad (1)$$

where n represents the number of county domain objects, i and j represent two counties, x means communication consumption expenditure, i.e. phone bill.  $w_{ij}$  is the space weight matrix, which represents the proximity between the space position i and j. When i and j are adjacent to the space position, using the Euclidean distance between the county points, and when the distance is greater than the set value,  $w_{ij} = 1$ . On the country, when  $w_{ij} = 0$ , under the condition that significant level is given, if the Moran's I is significantly positive, the higher or lower the communication consumption of the districts in space, and the more closer to 1 the value is. And the overall space difference is smaller. Conversely, if Moran's I is significantly negative, it shows that the distribution of communication between the county and its surrounding counties has a significant spatial difference, if the value of which is nearer to 1, the overall spatial difference is larger. Only when Moran's I is close to expected  $-1/(n-1)$ , the observed values are independent of each other and randomly distributed in space.

## Local Autocorrelation

Global spatial autocorrelation analysis is a spatial data analyzing method measuring inter-region spatial difference and correlation as a whole, which reflects the average clustering degree of intra-region similarity. However, when the sample data is enormous, global spatial correlation might black out the randomness of subset data. To uncover some local spatial clustering high-low values or anomalous patterns, local spatial autocorrelation method is introduced.

Global Moran's I statistic (Cervero & Kang, 2011; Su, Xiao, Jiang, & Zhang, 2012) is a general statistical index, indicating the average degree of spatial difference between counties. In the case that the overall spatial difference between districts and counties are shrinking, the spatial difference of the local area may be enlarged. In order to reflect the change trend of the spatial difference of the communication consumption, the ESDA local area analysis method is also needed. In order to recognize the autocorrelation of local space, the value of local spatial autocorrelation statistic of each spatial position is computed, and the formula of local Moran's I with space position as  $i$  is as such:

$$I_i = \frac{(X_i - \bar{X})}{\sum_{i=1}^n (X_i - \bar{X})^2} \sum_j w_{ij} (X_j - \bar{X}) \quad (2)$$

The standardized statistic of local Moran index test is:

$$Z(I_i) = \frac{I_i - E(I_i)}{\sqrt{VAR(I_i)}} \quad (3)$$

$E(I_i)$  and  $VAR(I_i)$  are its theoretical expectation and theoretical variance, and  $w_{ij}$  is the spatial weight. Among them, if  $I_i > 0$  and  $Z_i > 0$ , the district  $i$  is located in the H-H quadrant, which indicates that the communication consumption value of the districts and counties themselves is higher, and the spatial difference degree is small; if  $I_i > 0$  and  $Z_i < 0$ , the district  $i$  is located in the L-L quadrant, indicating that the communication consumption value of the county itself and surrounding counties is lower, and the spatial difference degree of the two is more insignificant.  $I_i < 0$  and  $Z_i > 0$ , the district  $i$  is located in H-L quadrant, which indicates that the communication consumption value of the district is higher, the surrounding counties is lower, and the spatial difference degree of the two is larger;  $I_i < 0$  and  $Z_i < 0$ , the district  $i$  is located in the L-H quadrant, indicating that the county and district's own communication consumption value is lower, that of the surrounding counties are higher, and the spatial difference between the two is higher.

## GIS Spatial Analysis

GIS (Geographic Information System), that is, the geographic information system. Spatial analysis is one of the core functions of geographic information system (Sánchez-García, Canga, Tolosana, & Majada, 2015; Wang & Chen, 2015). It is unique to the extraction, representation and transmission of geographic information (especially implicit information), which is the main function characteristic of geographic information system different from general information system. In this paper, GIS spatial analysis technology (Gimpel et al., 2015) is used to analyze the GDP and communication consumption clustering of 84 urban residents in Fujian Province, and the regional distribution map is formed to explore the regional differences. Global Moran's I statistic was used for spatial autocorrelation analysis in ArcGIS 10.0. Moran's I, p value and Z score were calculated to test the spatially clustered tendency between Communication Consumption of urban resident and GDP cases. Confidence level of 99% was selected. Values of  $P < 0.01$  were considered statistically significant.

## CASE ANALYSIS

### Study Area and Data Source

Fujian Province is located on the southeastern coast of China, facing Taiwan across the Taiwan Straits. The province is mostly mountainous, and is traditionally described to be "Eight Parts Mountain, one part water, and one part farmland". The northwest is higher in altitude, with the Wuyi Mountains forming the border between Fujian and Jiangxi. It is the most forested provincial level administrative region in China, with a 65.95% forest coverage rate in 2013. The highest point of Fujian is Mount Huanggang in the Wuyi Mountains, with an altitude of 2157 m. Fujian has a subtropical climate, with mild winters. In January the coastal regions average around 7-10 °C (45-50 °F) while the hills average 6-8 °C (43-46 °F). In the summer, temperatures are high, and the province is threatened by typhoons coming in from the Pacific. Average annual precipitation is 1,400-2,000 millimeters (55-79 in). Although Fujian is one of the wealthier provinces of China, its GDP (Gross Domestic Product) per capita is only about the average of China's coastal administrative divisions. In 2011, Fujian's nominal GDP was 1.74 trillion Yuan, a rise of 13 percent from the previous year. Its GDP per capita was 46,802 Yuan. By 2015 Fujian expects to have at

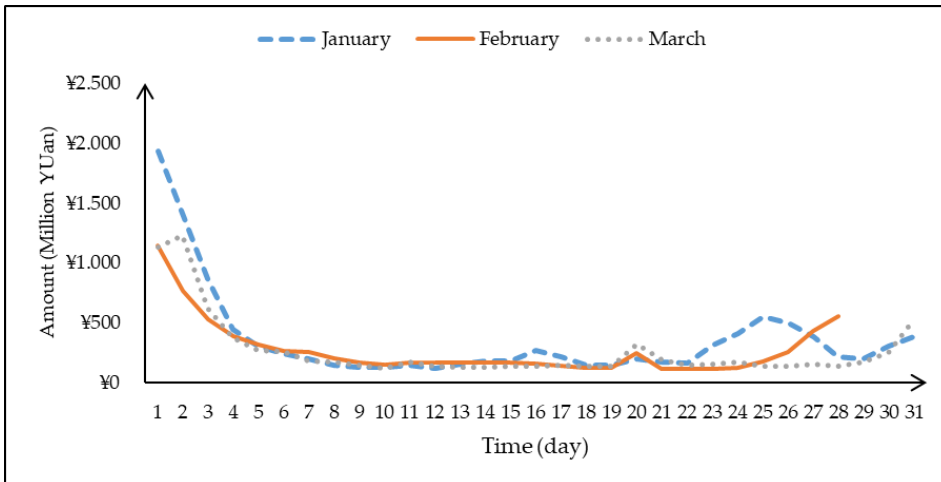


Figure 1. Average daily data distribution of communication consumer expenditure

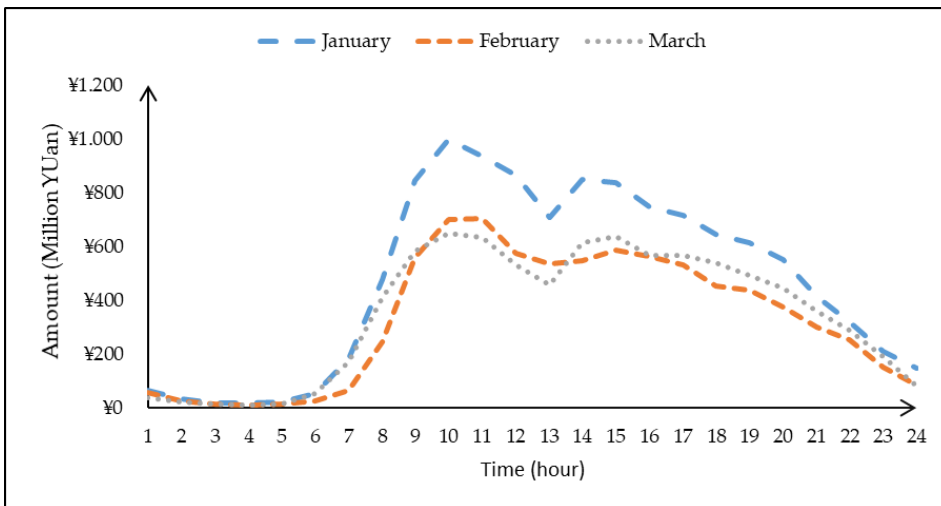


Figure 2. Hourly data distribution of communication consumer expenditure

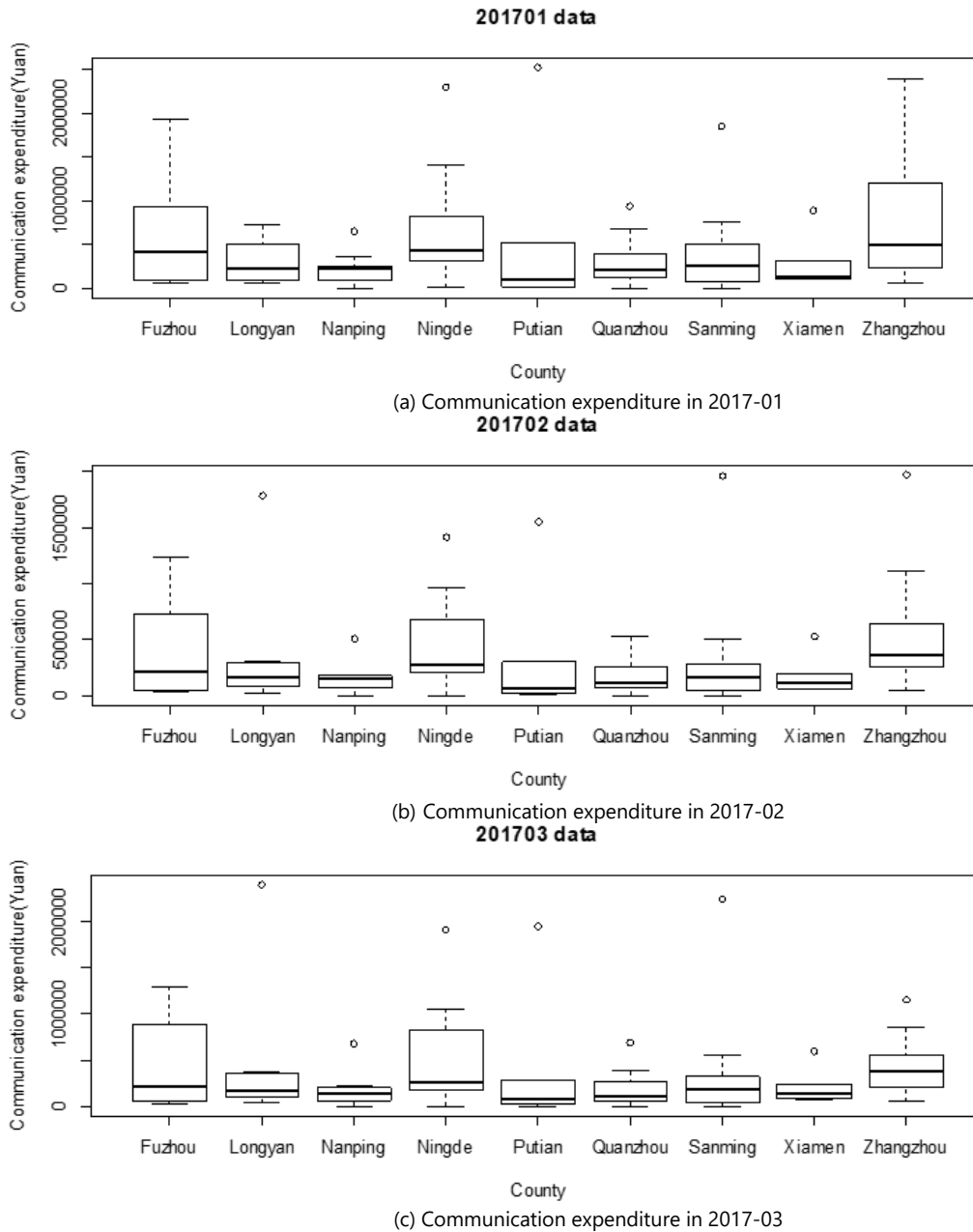
least 50 enterprises that have over 10 billion RMB in annual revenues. The government also expects 55 percent of GDP growth to come from the industrial sector.

In order to better reveal the difference of economic space between counties in Fujian province, in the exploratory spatial data analysis, the spatial analysis scale is defined as the county domain, including 9 prefecture-level cities, a total of 84 districts. By acquiring China's 1:1 million county area administrative division electronic map as the basic graphic data, with the application of GIS technology, the visual simulation and research of relevant statistical data are carried out. From the Fujian operator system, the masking data of the payment of operator agent office (dealer) from January to March, 2017 is extracted. After the data pre-processing (such as the deletion of the monthly consumption behavior of the irrational, incomplete field data, etc.), finally the qualified data of a total of 4,307,570 items are obtained and the GDP data mainly from the 2016 "Fujian Statistical Yearbook -2016". The data distribution is shown in Figure 1 and Figure 2.

From Figure 1 and Figure 2, it can be seen that the difference in the volume of communication consumer spending in different months is not significant. At the beginning and the end of the month, the trading volume appears a relatively high peak. The operator system conducts centralized checkout at the beginning and the end of the month, resulting in bulks of customer with no phone balance at the end of the month, thereby they need to top up. From the point of view of the transaction number of the consumer spending, the trading trend is basically the same, and the peak of the transaction occurs between 9 and 12. There is another small peak at 15 o'clock in the afternoon as well.

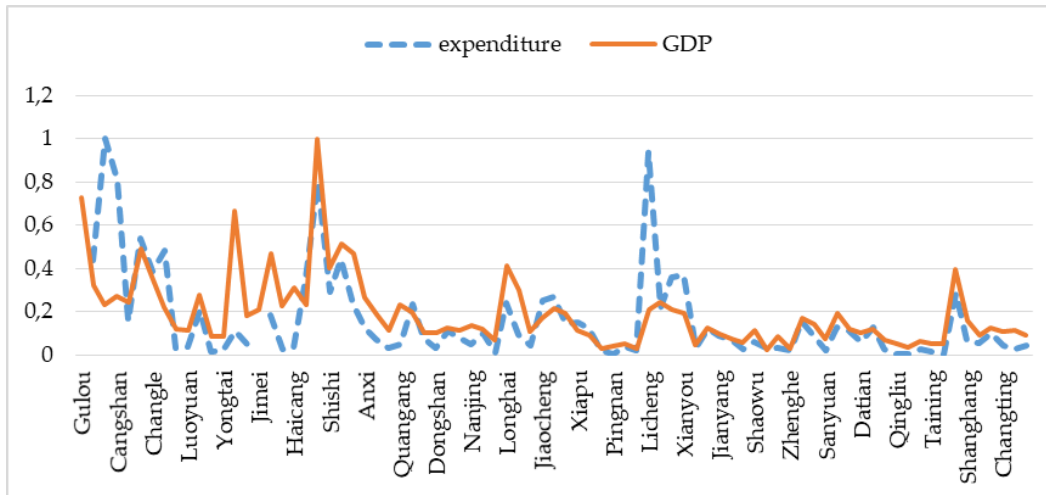
### Empirical Analysis

It is well known that the  $3\sigma$  regular or the z-fraction method based on normal distribution assumes that the data obeys the normal distribution, but the actual data is often not strictly obey the normal distribution. Their criteria



**Figure 3.** Communication Consumption of the Resident in Fujian County

for judging outliers are based on the mean and standard deviation of the data batches, and the robustness of the mean and standard deviation is very small, and the exception value itself will have a large impact on them, resulting in a number of outliers not exceeding 0.7%. It is obvious that the effectiveness of this method is limited in judging abnormal values in non-normal data. The drawing of the box-plot diagram relies on the actual data and does not require prior assumption that the data is subject to a specific distribution form. Without any restrictive requirements for data, it is just a true and intuitive representation of the original shape of the data; the standard of judging anomaly value of Box line chart is based on four-bit and four-bit distance, four-digit number has certain robustness, up to 25% Data can become arbitrarily far without disturbing the four-bit number, so the anomaly value cannot be affected by this standard, the result of the identification of the abnormal value of the box line diagram is more objective. Therefore, in order to improve the research accuracy, we use the box-plot diagram to find out the outliers, Upper four quartile Q1 smaller than  $1.5 * \text{four quartile range}$ :  $Q3 - Q1$  or lower four quartile  $Q3$  larger than  $1.5 * IQR$  is used as the outlier; from January to March in 2017, the box line of communication consumption of Fujian counties is shown in [Figure 3](#).



**Figure 4.** The Relationship between Communication Expenditure and GDP

For an example, we remove the 3 outliers from the Quanzhou and Zhangzhou in 201701 (**Figure3 (a)**). After removing the outliers, we can explore the relationship between communication consumption and GDP, because different variable data dimensions differ, they are uniformly normalized to 0 and 1, and then the contrast curves are made. As shown in **Figure 4**.

It can be seen from **Figure 4**, those counties that GDP is higher, the residents of the average communication expenditure is more, which indicates that the communication consumption expenditures in the county area of the province are positively correlated. In order to further clarify the regional differences between 84 counties in Fujian Province, the GDP and the communication consumption index of each county in the year of 2017 were clustered separately.

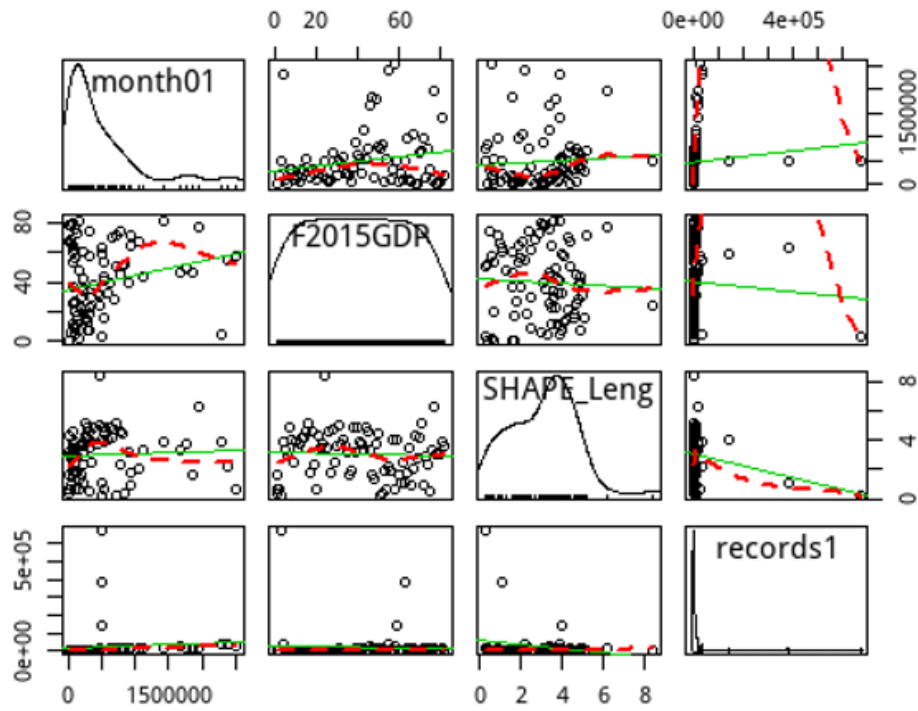
The Moran's I values of communication consumption expenditure during the January to March in 2017 are all above 0.48 under the significance level of  $p < 0.001$  by computing, which denotes a significant positive spatial correlation exists. This means that counties with high values are spatial adjacent to areas with high values, and counties with low values are also spatial adjacent to that with low values.

If we want to examine the correlation between multiple variables at the same time, it is very troublesome to draw a simple scatter plot between them. The scatterplot matrix can be used to plot the scatter plots of the variables to find out the main correlation between variables quickly. Scatterplot matrix can assign the binary relationship between variables, the junction of two variables is their scatterplots, and the plots are the same and below the main diagonal. We can only demonstrate the upper triangular or lower triangular figures by adjusting parameters. There are kernel density figures in the main diagonal, while the others have linear or smoothly fitted curves.

We explore the relationship between the cost of each month's communications expenses and other factors, including GDP, number of transactions, and regional length (which can be used as a regional area). As can be seen from the **Figure 5**, the monthly communication expenditure presents a single peak curve, and each prediction variable is skewed in some degree. Communication consumption increases with the increase of GDP, and the change trend of trading times is basically the same, but with the increase of area, it has a certain decrease. This shows that the region with high economic level has correspondingly higher communication consumption, but with the increase of regional area, this is because the area of the western counties in Fujian province is larger, the economy is relatively backward, and the amount of communication is less.

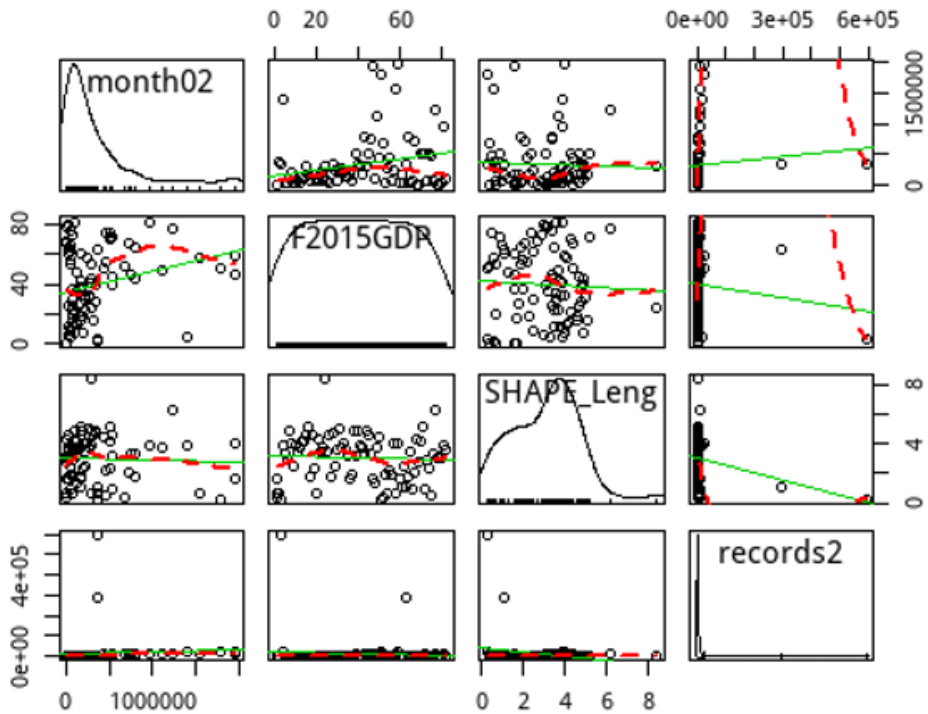


### Scatter Plot Matrix via 201701



(a) Scatter Plot Matrix via variable of 201701

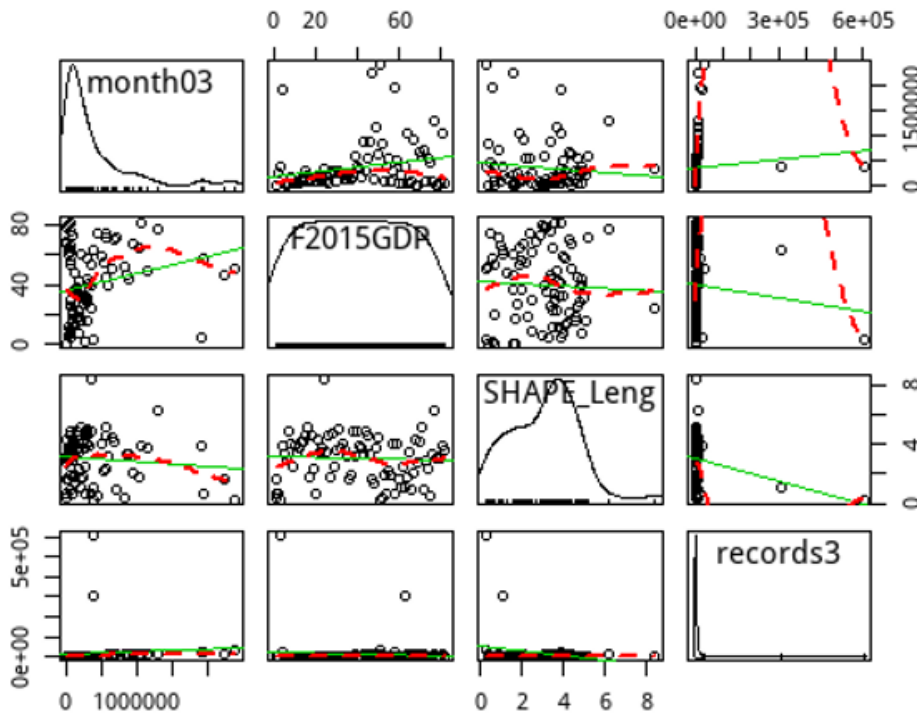
### Scatter Plot Matrix via 201702



(b) Scatter Plot Matrix via variable of 201702

**Figure 5.** The Results of Scatter Plot Matrix

### Scatter Plot Matrix via 201703



(c) Scatter Plot Matrix via variable of 201703

**Figure 6 (continued).** The Results of Scatter Plot Matrix

**Table 1.** Cluster distribution of communication expenditure

Time	201701	201702	201703
HH	3	4	3
LL	7	5	5
LH	5	4	3
HL	0	0	0

When the distance matrix is applied, the appropriate distance thresholds shall be chosen to obtain the appropriate number of adjacent regions, thereby better describing the distribution of the data in this case. If the distance threshold is too large or too small, it is possible to obtain data space autocorrelation that is rather insignificant.

It can be seen from **Table 1** and **Figure 6**, among three months in 2017, it is a very small number of counties and cities in the HH, LH and LL quadrant, most of them show a not significant. The "high-high" are also referred to as "hot spots", whereas the "low-low" are referred to as "cold spots".

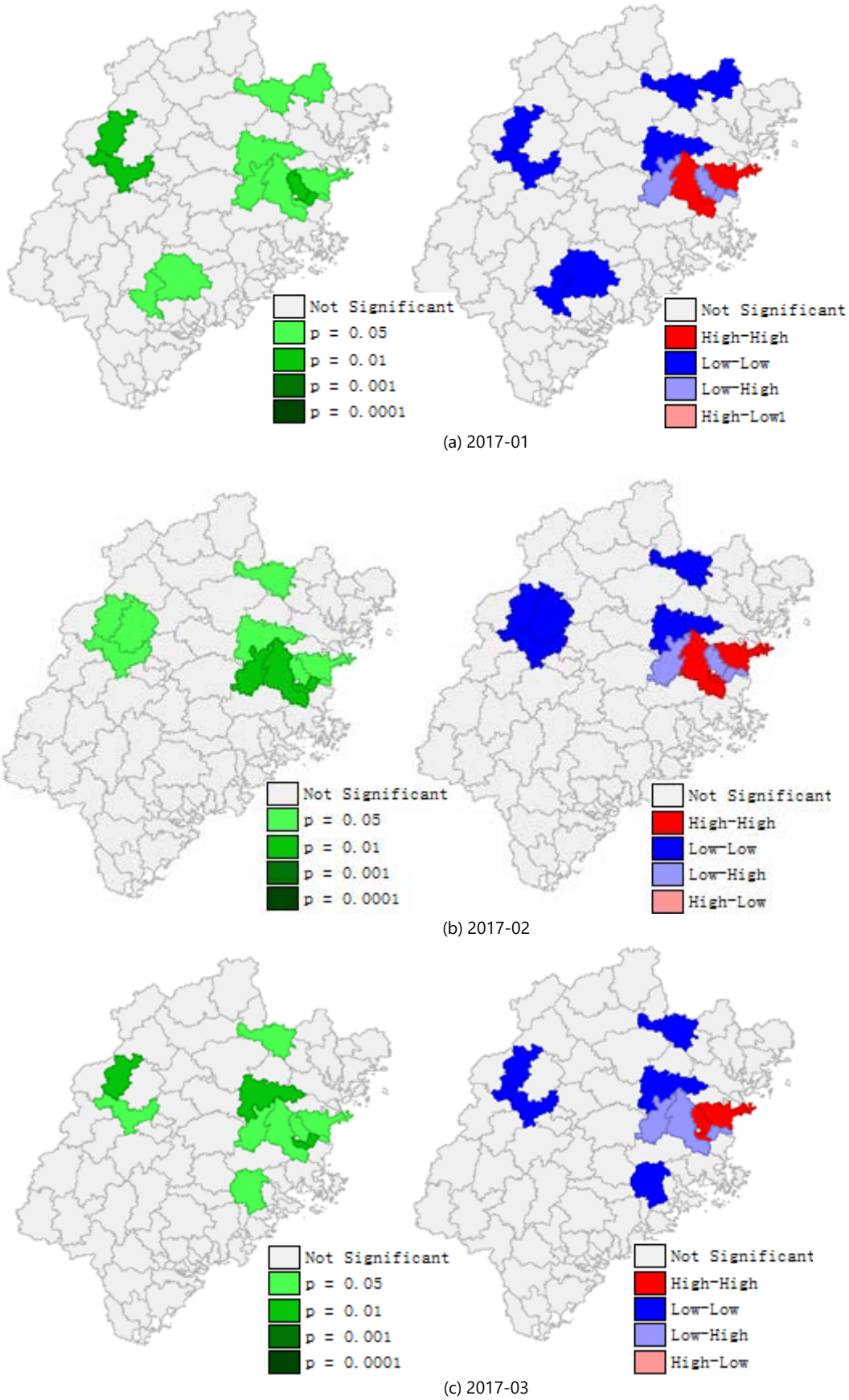
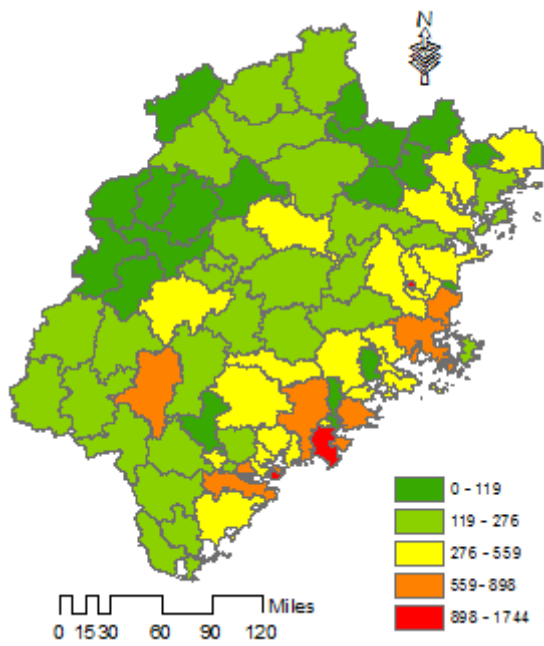


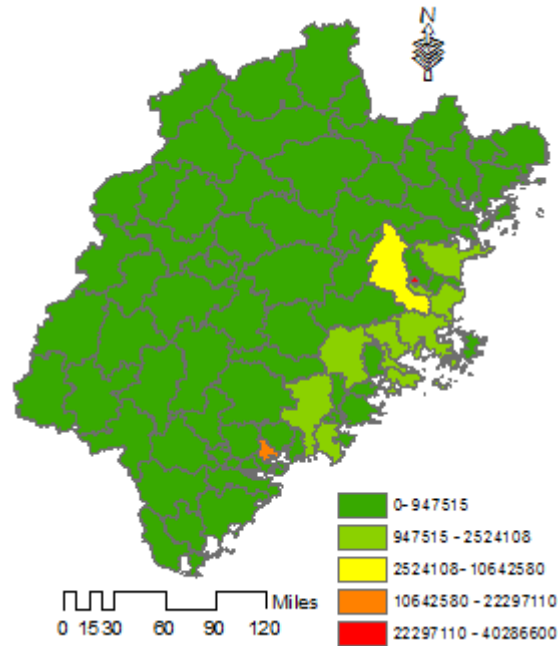
Figure 7. The autocorrelation clustering of communication expenditure

Significant differences were found in the local evolution of the distribution pattern of characteristic factors of average communication expenditure in Fujian over the three months. The communication consumption expenditure of each county inhabitant has the spatial correlation, which manifests as follows: Gulou District, Jimei District, Licheng District and the East Coast's communication expenditure concentrate in a high degree. While the Northwest region has Low gathering degree; simultaneously, there also appears spatial heterogeneity and non-stationary, that is, the urban inhabitant correspondence consumption expenditure has obvious difference. The results from LISA (Local Indicators of Spatial Association) in **Figure 4** shows that the county area with p value equal to 0.05, such as Jinan District and Changle area, has a significant high value agglomeration, that is, local and peripheral communication consumption expenditure are both higher. There is no region with P value less than 0.0001, there is no significant low concentration area, which indicates that there is a certain correlation between each county and GDP. "Hot spots" and "cold spots" are both very prominent. 7 areas including Lianjiang County, Changle City, Jinan District, Minhou County, Fuqing City, Xianyou County and the Xiuyu District of Putian City are clustering in HH-type, which are the "hot spot" area where the expenditure of communication consumption is concentrated; there are 16 "cold spot" areas, mainly located on the northwestern edge, such as Ninghua County, Jianning County, Taining County, Shaowu City, Guangze County and so on, with the factors clustering in LL-type. In addition, there are 3 distinct "singular value" county domains, which are in contrast to the surrounding counties, considered as significant HL or LH-type heterogeneous regions, such as Yongan City, Luoyuan County and Pingtan County.

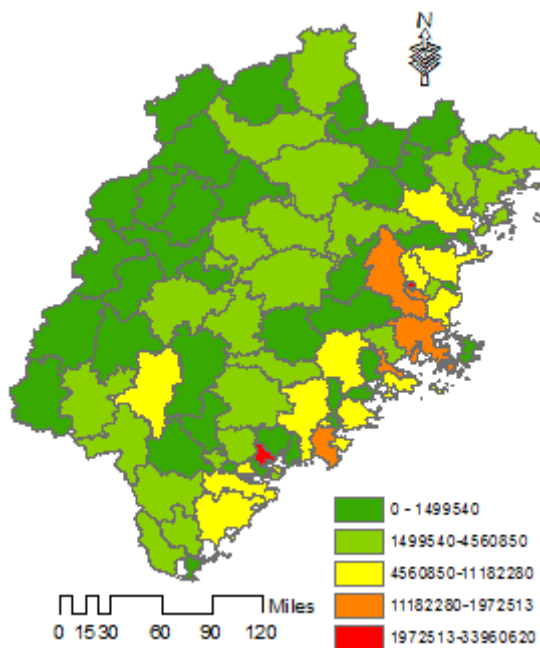
From **Figure 7** we can see that the spatial distribution of urban residents' communication expenditure behavior in different counties of Fujian province is not scattered, but has some inherent regularity, that is, they have positive autocorrelation relationship. However, this kind of regularity manifests as a kind of cluster phenomenon in the space of communication consumption expenditure of certain county area, that is, high ones tend to be adjacent, and low ones tend to be adjacent, which indicate that the county area with higher consumption ability is relatively close to the county area with higher consumption ability, or the county area with lower consumption ability is relatively closer to the county with lower consumption ability. In the comparison between the GDP distribution in the county and the monthly expenditure of the communication consumption, the amount of GDP increase will, in some degree, result in the increase of the residents' communication consumption expenditure, and there is a certain correlation between GDP and the communication consumption. But the communication consumption expenditure and the economic development degree are not completely positively related, which is due to that the consuming ability and the expense tendency of different groups are different. Thus, this generated a significant difference in their communication consumer expense. For example, the Yanping District of Nanping City and Yongan City have high GDP figure, however, the communication consumption expenditure and its surrounding counties and districts are not much. Meanwhile, in the western region of Fujian, it also shows that the consumption expenditure of the residents still has a considerable space to improve, and the consumer demand for communications is not completely released. Contributed by the rising income level, the communication expenditure per person will increase. And the communication market still has great potential. This paper uses three-month long period as our time scale, if a longer time period was utilized, the research results would be more precise and convincing. During the study process, county-level areas of Fujian province are our study units, whether or not finer township level study units lead to a different research result is conducive for future discussions.



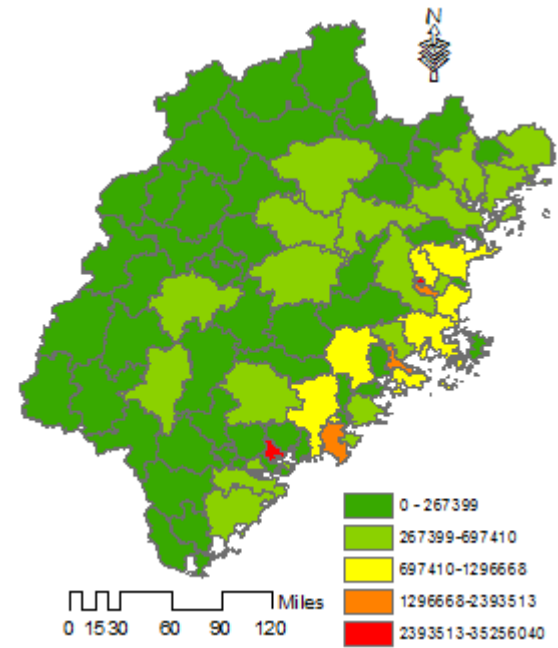
(a) Distribution of County GDP in 2016



(b) Distribution of communication consumption in January



(c) Communication consumption distribution in February



(d) Communication consumption distribution in March

**Figure 8.** The relationship between consumer spending and GDP

## CONCLUSIONS

In the information age, there is a higher demand for the ability of data analysis of talents, which is different from the requirement of cultivating the ability of data analysis in teaching. Students of modern specialties need to have a certain ability of data analysis and collation, so as to meet the actual work of the collection, collation, analysis of all kinds of data needs. Therefore, modern colleges and universities must make clear the importance of training students' ability of data analysis, in order to train the thinking of the ability of data analysis throughout the teaching process, and implement the theory and practice of data analysis into the teaching process of various subjects. On

the basis of subject content, we should carry out practical teaching activities, improve students' ability of data analysis and promote students' comprehensive quality and employment competitiveness.

Geography not only studies spatial distribution and characteristics of geographical things, but also clarifies spatial differences and spatial relations. It is devoted to revealing spatial movement and law of spatial change of geographical things. GIS can help learners develop spatial ability, solve geospatial problems, and improve learners' spatial reasoning ability and spatial thinking level. In this paper, we use exploratory data analysis, spatial weight matrix, scatterplot, global spatial autocorrelation analysis, and local spatial autocorrelation analysis to study Fujian communication consumption expenditure, and explore and analyze some of characteristics and anomalies. Since all kinds of data taken from real world of life exist on a certain spatial location, it is difficult to satisfy idealized condition of mutual independence between data in adjacent spatial position of a variable. Therefore, application and development of spatial autocorrelation index analysis in field of national economy has a very broad application prospect. For students majoring in GIS, mastering this analysis method is of great significance to help students learn geography knowledge, to understand relationship between people and environment, and to solve geographical problems. However, use of ESDA method to cultivate learners' spatial ability also needs curriculum support, so it is necessary to develop high-quality and challenging GIS classroom learning model.

### ACKNOWLEDGEMENTS

This work was supported by the Science and Technology Project of the Education Department of Fujian Province of China (No. JAT170652), the Project of Innovation Team of Ningde Normal University (No.2017T05), and the Project of Ningde Normal University Tea Industry and Culture special project (No.2017C023). The authors appreciate the valuable comments and suggestions from the editors and reviewers.

### REFERENCES

- Anselin, L. (1998). Exploratory spatial data analysis in a geocomputational environment. In: P. A. Longley, S. M. Brooks, R. McDonnell, B. Macmillan (eds.) *Geocomputation – A Primer*, pp. 77-94. Wiley, Chichester.
- Anselin, L. (1999). Interactive techniques and exploratory spatial data analysis. In: Longley, P.A., Godchild, M.F., Maguire, D.J. (Eds.), *Geographical Information Systems*. John Wiley & Sons, New York, pp. 253-266.
- Anselin, L., Sridharan, S., & Gholston, S. (2007). Using exploratory spatial data analysis to leverage social indicator databases: the discovery of interesting patterns. *Social Indicators Research*, 82(2), 287-309.
- Cervero, R., & Kang, C. D. (2011). Bus rapid transit impacts on land uses and land values in Seoul, Korea. *Transport Policy*, 18, 102-116.
- Geary, R. C. (1954). The contiguity ratio and statistical mapping. *The Incorporated Statistician*, 5, 115-145.
- Getis, A., & Ord, J. K. (1992). An analysis of spatial association by use of distance statistic. *Geographical Analysis*, 24(3), 189-206.
- Gimpel, A., Stelzenmüller, V., Grote, B., Buck, B. H., Floeter, J., Núñez-Riboni, I., ... Temming, A. (2015). A GIS modelling framework to evaluate marine spatial planning scenarios: Co-location of offshore wind farms and aquaculture in the German EEZ. *Marine Policy*, 55, 102-115.
- Moran, P. A. P. (1950). Notes on continuous stochastic phenomena. *Biometrika*, 37, 17-33.
- Sánchez-García, S., Canga, E., Tolosana, E., & Majada, J. (2015). A spatial analysis of woodfuel based on WISDOM GIS methodology: Multiscale approach in Northern Spain. *Applied Energy*, 144, 193-203.
- Su, S. L., Xiao, R., Jiang, Z. L., & Zhang, Y. (2012). Characterizing landscape pattern and ecosystem service value changes for urbanization impacts at an eco-regional scale. *Appl. Geogr.*, 34, 295-305.
- Tobler, W. (2014). On the first law of geography: A reply. *Annals of the Association of American Geographers*, 94(2), 304-310.
- Wang, C.-H., & Chen, N. (2015). A GIS-based spatial statistical approach to modeling job accessibility by transportation mode: case study of Columbus, Ohio. *Journal of Transport Geography*, 45, 1-11.
- Yang, Y., & Wong, K. K. (2013). Spatial distribution of tourist flows to China's cities. *Tour. Geogr.*, 15(2), 338-363.
- Zhang, Y., Xu, J. H., & Zhuang, P. J. (2011). The spatial relationship of tourist distribution in Chinese cities. *Tour. Geogr.*, 13(1), 75-90.



## Modular Curriculum Designed for the Environmental Education of 6<sup>th</sup> and 7<sup>th</sup> Grade Students in the North Cyprus

Şerife Gündüz <sup>1</sup>, Gülsüm Aşıksoy <sup>1</sup>, Umut Öksüz <sup>1\*</sup>

<sup>1</sup> Near East University, Nicosia, CYPRUS

Received 20 January 2018 • Revised 12 February 2018 • Accepted 12 February 2018

### ABSTRACT

The environment can be defined as the whole system where the history and culture of people who live is constantly utilized while forming them with all natural beings in relation and interaction with each other. The ecosystem has changed with the impact of occasional natural events, and has reached a balance. However, since the first existence of people, they started to increasingly form the natural habitat in the way they desired, which led to a fast deterioration in the natural balance of the ecosystems. In the beginning. Such impacts were very limited; however, they had reached a momentum after the industrial revolution.

**Keywords:** modular curriculum, environmental education, environment

### INTRODUCTION

The balance had started to be on the negative side of nature in the relationship between nature and mankind. Due to the production, methods and mechanisms of mankind, it had become very difficult for nature to protect itself and stay within the tolerance levels through the regeneration opportunities; and it even reached an irrevocable process. Additionally, there are many examples. The seasons are changing, the glaciers are melting, the forests are destroyed wildly, the air that we breathe is loaded with poison and our ears, eyes and brain are being filled with noise, concrete and metal pollution. The basis of environmental education is the protection of nature and natural resources. In addition to providing information, environmental education should influence human behaviour. The main objective of environmental education is to provide positive and permanent behavioural changes and ensure the active participation of individuals in the problem solution. An effective environmental education program is only possible with qualified teachers with positive environmental attitude and who are sensitive to environmental problems. Only such teachers can give knowledge, raise awareness of students about the environment in addition to contributing to the development of values and attitudes of students (Yıldırım, 1996). The students with negative attitudes towards the environment are considered to be less sensitive to environmental problems and even create problems against the environment (Uzun & Sağlam, 2006).

Another reason that leads the students to a negative attitude might be their lack of knowledge on the environment. The students have very little knowledge about the concepts of environmental education; they do not know the meanings of concepts and they do not completely perceive such concepts (Atasoy & Ertürk, 2008). Students learn the correct information from the printed and visual media rather than their families or at schools, which might be another reason for the lack of knowledge among students on the environmental (Darçın, Bozkurt, Hamalosmanoğlu & Köse, 2006).

There are a total number of five scenarios regarding the problem solving skills of students. These include Environmental awareness Ecosystem, Environmental events and Environment and humans. The problem “what is the impact on the problem solving skills of students?” was discussed based on the findings generated from the scenarios in relation to the problem solving skills of students. The high level of total scores among groups indicates the effectiveness of the curriculum since the application of activities was in accordance with the 5E learning model. The students were familiar with the topics via activities and the scenarios and topics were interesting for the students (Balgopal & Wallace, 2009; Gül & Yeşilyurt, 2011; Özsevgeç & Artun, 2012c). The scenarios were interesting, suitable to the levels and related with the everyday life problems. Through the modular curriculum,

#### Contribution of this paper to the literature

- The developed environmental education modular curriculum would provide more chances to students in the class environment so that they would be more effective, and would facilitate them to think on the environmental problems that they would encounter throughout their lives, generate solutions and lead to solving such problems.
- The modular curriculum would help students to work towards a solution for of the environmental problems around them, and become individuals with environmental literacy through increasing their knowledge of environmental topics.
- The environmental education modular curriculum would provide guidance to teachers with regard to the environmental education with the activities developed suitable for students effective in the learning process of students, economical as well as being easy-to-use, and lead them to appreciate environmental education.

students had the chance to do research within the framework of various projects and ensure the correct description of existing problems, and to reach effective outcomes by following a systematic order such as the options required for solution and selection of the most suitable method.

Such circumstances might cause the development of negative attitudes towards the environmental among students. The abovementioned problem shows that the activities and practices at schools, which would ensure environmental awareness among students, help them to solve environmental problems and develop their problem solving skills, are not sufficient (Özsevgeç & Artun, 2012a; Şimşekli, 2001). At this level, all efforts would not go beyond the identification of environmental problems and transfer of theoretical information about the reasons for such problems to the students. As a natural outcome, the students would not create solutions for the environmental problems, would not form environmental awareness, would not maintain their conceptual learning and attitude change, and hence would not develop their problem solving skills as they would not have active participation in the solution of environmental problems (Taycı & Uysal, 2009). The 5E methods is believed to be useful for these kind of tasks.

The following paragraphs include explanations of both the 5E Learning Cycle phases and the major tasks for the teacher and students in each phase (Bybee & Landes, 1988; Stamp & O'Brien, 2005). As for the 5E methods, it represent five stages of a sequence for teaching and learning: Engage, Explore, Explain, Extend and Evaluate. As The 5E learning cycle leads students through a sequence of learning in which they become engaged in a topic, explore that topic, are given an explanation for their experiences, elaborate on their learning, and are evaluated. (Wilder & Shuttlesworth, 2005).

Engagement phase (E1): The teacher assesses students' prior knowledge and engages students in learning a new concept. The teacher also helps students make connections between prior and present knowledge, and helps to organize students' thoughts about the learning outcomes of present activities.

Exploration phase (E2): The teacher provides students with a common base of activities reflective of present concepts and skills. Students complete activities by using their prior knowledge to generate new ideas, to explore questions and possibilities, and to execute a preliminary investigation.

Explanation phase (E3): The teacher focuses students' attention on a specific aspect of their "engagement" and "exploration" experiences, and provides opportunities for students to demonstrate their understanding or skills. The teacher can also use direct instruction and guide the students toward a deeper understanding of a concept.

Elaboration phase (E4): The teacher challenges and extends students' conceptual understanding and skills. Students learn to develop broader and deeper understanding and skills, through the above three phases.

Evaluation phase (E5): The teacher evaluates students' progress toward achieving the instructional goals. Students learn to assess their understanding and abilities.

A modular curriculum organises multi-dimensional activities covering plant and animals. The modular curriculum allows the 6<sup>th</sup> and 7<sup>th</sup> grade students to observe the features of plants and animals around them just like a scientist, to take notes and share those notes in the classroom, all of which contribute to the understanding of such concepts. Another significant component of the designed curriculum is that during the learning process, students are always active, namely students actively participate to the activities, observations and in-class discussions. Within the framework of the designed curriculum, the achievement tests were utilised to identify the products of students while projects and self-assessment were used to reflect the performances of students, as the aim is to demonstrate to the students all aspects and allow them to assess themselves. Hence, the curriculum might have allowed the students to constantly review themselves to identify their deficiencies (Özsevgeç, 2007) and improve themselves. Such a feature of the modular curriculum might have improved their conceptual understanding. It is easy to interpret this as the more suitable education strategies are, the better it is for students.

**Table 1.** Sample Size and Applications of Research

Process	Activities
	Identification of research problem
<b>Design of Environmental Education Modular Curriculum</b>	Literature review
	Identification of acquisitions
	Description of chapters
	Development of data collection tools
	Preliminary and final tests of achievement tests
	Preliminary and final tests of environmental education attitude scale
<b>Pilot Study</b>	Final test of environmental education self-assessment form
	Validity analysis of data collection tools
	Reliability and validity analyses of data
	Preliminary and final tests of environmental education attitude scale
<b>Original Study</b>	Pilot applications based on the problem solving skills
	Final test of environmental education self-assessment form
	Final test of integrated learning environment survey

With that feature, the utilisation of methods and techniques like group work, brainstorming and discussion during the same lesson might have improved the conceptual understanding of students (Coca, 2013).

Despite of the fact that there is no significant difference between the environmental attitudes of students, the provision of an interactive education process opportunity to the students via the designed curriculum (Sarıay, 2008; Taş & Seçken, 2009) and application of students oriented practice together with various features might cause a change in the attitudes of students. The outcome of the designed curriculum supports such studies; and the use of different methods and techniques in the application might have increased the attitudes of students (Ergin & Okutmuş, 2007). The lack of supplementary education tools cause a major deficiency in environmental education, as such tools cover the relevant benefits/topics, support the environmental education concepts with enriched activities and facilitate the students to generate solutions to environmental problems.

Therefore, the aim of the environmental education modular curriculum designed in the study is to identify the impact on the conceptual understanding and academic success of 6<sup>th</sup> and 7<sup>th</sup> grade students in North Cyprus.

## MATERIAL AND METHODS

### Data Collection Tool

The data collection tools of this research are “Achievement Test Based on Chapters”, “Environmental Education Attitude Scale”, and “Environmental Activities Assessment Survey” based on the sub-problems.

“The Integrated Multiple Case” pattern, which reviews all data as a whole, is a part of a specific case suitable for the nature of the study, and is used in the five different chapters under the modular curriculum designed for this study had formed multiple variable. Each chapter is analysed separately to understand the internal changes and process, and then to understand the efficiency of the implementation process (Cohen & Manion, 1989; Çepni, 2010).

### Research Sample

During the pilot and original implementation of the research, it was ensured that the researcher would perform the research much easier; the researcher would be enthusiastic and voluntary during the application; the students would show similar characteristics from every aspect and the physical facilities of school would be suitable for the research. The sample of the study comprised of a 30-person sample group from two schools selected using the random sampling method. The sample size and implementation of the study are given in **Table 1**.

Prior to the performance of the pilot study, the teacher, who would help the in the implementation was discussed with in relation to the guide materials and assessment tools and provided with the information on the guide materials, assessment tolls and period of administration. Information exchange was also conducted with the teacher that would help in the administration prior to and after the lesson about what would be done. As the pilot and original study were both conducted by the same teacher, the related teacher was observed to be more experienced during the original study. It is known that the teacher had knowledge on the 5E learning method and was giving consideration to apply such a model in his classes and conducting activities accordingly.

The willingness of the assistant teacher in such activities contributed to bringing the guide materials and data collection tools to the final shape as the teacher adopted the pilot and original study, was helpful as much as possible and in providing information about the status of the students.

## Validity and Reliability

The reliability and validity of data collection tools of this study are crucial. Therefore, the reliability and validity of data collection tools must be conducted. The data collection tools were tested through a pilot study on the 6<sup>th</sup> and 7<sup>th</sup> grade students of Atleks Sanverler and Turk Maarif Koleji located in North Cyprus.

In consideration of the evaluation of collected data, the data collection tools were found to be valid and could be used in the study. Under the modular curriculum, there are achievement tests for five different chapters. As a result of the pilot study, the Cronbach's alpha reliability coefficients of tests were .791 for the "Environmental Awareness Chapter", .743 for the "Ecosystem Chapter", .891 for the "Plants and Animals Chapter", .816 for the "Environmental Events Chapter" and .823 for the "Environment and Human Chapter" respectively. Such reliability coefficients can be considered as good and suitable for the study (Büyükoztürk et al., 2017). The Cronbach's alpha reliability coefficient of the environmental education attitude scale was calculated as .892, which could be considered as at a good level (Çepni, 2010). The Cronbach's alpha reliability coefficient of the environmental activities assessment survey was calculated as .761.

## Data Analysis

The research data were collected through the environmental education attitude scale, environmental activities which included assessment surveys, scenarios on problem solving skills and achievement test. In order to identify the variance in the environmental attitudes of students, t-test, frequency of answers in the environmental activities assessment and daily notes of researcher for the observations were analysed.

The SPSS 20 program was utilised to statistically analyse the findings from the environmental attitude scale and achievement tests. The achievement tests, which would be used as preliminary and final tests of chapters, were conducted to measure the change aspect of knowledge levels of students for each chapter. T-test analysis was conducted for the identification of whether or not there is any significant relation between the final test scores of the five chapters in the modular curriculum. The views of students regarding the activities of student guide materials were identified through the environmental activities assessment survey. Pilot activities were performed for the guide materials developed in the study and an assessment was undertaken accordingly. Evaluation of the pilot study results, the guide materials and assessment tools prepared for the original study were administered on the last 2 hours of lessons during the 5 weeks as the complete 2nd semester of 2016-2017 academic year was the original study period. Firstly the research problem was determined for the application of the environmental education modular curriculum. A literature review was conducted. Chapters were described as; environmental awareness, ecosystem, plants and animals, environmental events, environment and humans. Guide materials were developed and environmental education attitude scale, scenarios on the problem solving skills and an achievement test were administered. The preliminary and final tests were conducted and then finally the results were reported.

## Data Collection Tools

The achievement test developed for the five chapters of the research "Environmental Awareness", "Ecosystem", "Plants and Animals", "Environmental Events" and "Environment and Humans" were used in the analysis. For each of the chapters, the analysis results of the achievement test results were identified. After the evaluation of the preliminary and final test results of the achievement tests were administered to the sample group, a t-test was performed to identify whether or not the difference between the preliminary and final tests were statistically significant. The related results are given in [Table 2](#).

## FINDINGS

As seen in [Table 2](#), there is a statistical significant difference in favour of the final test For the Environmental Awareness Chapter,  $p = .000$ ,  $p < 0.05$ ), for the Ecosystem Chapter,  $p = .003$ ,  $p < 0.05$ ); for the Plants and Animals Chapter,  $p = .005$ ,  $p < 0.05$ ); for the Environmental Events Chapter,  $p = .001$ ,  $p < 0.05$ ); and for the Environment and Humans Chapter,  $p = .003$ ,  $p < 0.05$ .

**Table 2.** T-Test results on the achievement test

Chapters	Group	N	Standard Deviation	t	p
1. Environmental Awareness Chapter	Preliminary test	30	6.23	7.22	.000
	Final test				
2. Ecosystem Chapter	Preliminary test	30	6.79	6.51	.003
	Final test				
3. Plants and Animals Chapter	Preliminary test	30	3.47	6.13	.005
	Final test				
4. Environmental Events Chapter	Preliminary test	30	8.29	7.39	.001
	Final test				
5.Environment and Humans Chapter	Preliminary test	30	10.69	4.63	.003
	Final test				

**Table 3.** T-test results on the environmental attitude scale

Group	N	Arithmetic Average	Standard Deviation	t	p
Preliminary test	30	126.75	19.25	9.23	.007
Final test					

The problem of study was "Is there a significant effect of the designed environmental education modular curriculum on the environmental attitudes of 6<sup>th</sup> and 7<sup>th</sup> grade students from the schools in North Cyprus?" The objective in using such assessment tools is to reflect the changes in the environmental attitudes of students in detail. After the evaluation of the preliminary and final test results of achievement tests administered to the sample group, a t-test was performed to identify whether or not the difference between the preliminary and final tests are statistically significant. The related results are given in **Table 3**.

As seen in **Table 3**, there is no statistical significant difference in favour of final test among the preliminary and final test results of students ( $p = .007$ ,  $p > 0.05$ ).

The problem of the study was identified as "What is the effect of the designed environmental education modular curriculum on the problem solving skills of 6<sup>th</sup> and 7<sup>th</sup> grade students from the schools in North Cyprus?" There were a total number of 5 scenarios regarding the problem solving skills of students in the "Environmental Awareness Chapter", the "Ecosystem Chapter", the "Environmental Events Chapter" and the "Environment and Humans Chapter". The findings with regard to the application of scenarios on the 6<sup>th</sup> and 7<sup>th</sup> grade student groups in the North Cyprus are given in **Table 4**.

During the application of this skill, we used five steps. The first step was "determine the problem", second step was "collection of information", third step was "investigation of probing solutions", fourth step was "determination of solutions", and the final step was "problem solving."

**Table 4.** Total scores from the application of “Scenarios In Relation With The problem Solving Skills” on the student groups

Chapters	Name of Groups	I. Step: Identification of Problem	II. Step: Information Collection	III. Step: Searching for Problem Solving	IV. Step: Identification of Solution	V. Step: Problem Solving	Total Score
“Environmental Awareness” Chapter	ÇB1	6	5	3	5	5	24
	ÇB2	3	3	3	4	4	20
	ÇB3	5	5	4	6	3	23
	ÇB4	4	3	4	5	5	21
	ÇB5	4	5	5	6	6	26
“Ecosystem” Chapter	EK1	5	3	3	5	4	21
	EK2	3	4	5	3	5	20
	EK3	4	2	2	3	5	16
	EK4	3	2	6	2	4	17
	EK5	3	5	5	4	2	19
“Plants and Animals” Chapter	BH1	3	2	4	5	3	17
	BH2	5	3	4	4	6	22
	BH3	6	2	4	3	3	18
	BH4	3	4	4	3	3	17
	BH5	5	5	6	2	5	23
“Environmental Events” Chapter	ÇO1	5	5	3	3	4	20
	ÇO2	2	3	2	5	3	15
	ÇO3	6	2	5	4	5	17
	ÇO4	3	6	5	3	4	21
	ÇO5	5	4	6	5	3	23
“Environment and Humans” Chapter	Çİ1	4	4	5	6	4	23
	Çİ2	5	2	4	5	5	21
	Çİ3	5	2	6	3	2	18
	Çİ4	3	5	3	4	4	19
	Çİ5	4	3	6	2	5	20

Students can only get 7 points as the lowest and 27 points as the highest

As seen from **Table 4**, the ÇB group got 114 points in total, the EK group 93 points, the BH group 97 points, the ÇO group 96 points and the Çİ group 101 points.

The environmental activities assessment survey was conducted to identify the views of 6<sup>th</sup> and 7<sup>th</sup> grade students from the schools in North Cyprus about the activities in the student guide material. The survey has a total of 22 items and is in the form of a 5-point likert scale as ranging from “Strongly Agree”, “Agree”, “Neutral”, “Strongly Disagree” and “Disagree”. The complete arithmetic averages of data generated from the environmental activities assessment survey are given in **Table 5**.



**Table 5.** Arithmetic Averages of Environmental Activities Assessment Survey

No	Items	Chapter (ÇB)	Chapter (EK)	Chapter (BH)	Chapter (ÇO)	Chapter (Çİ)
1	The group activities have made us more environmentally conscious.	3.21	3.36	3.65	3.56	3.43
2	I couldn't understand the topic in the activities requiring group work.	3.17	3.65	3.41	3.21	3.46
3	The environment was good in group work activities	3.21	3.54	3.18	3.45	3.65
4	I enjoyed the activities of the chapter.	3.63	3.21	3.56	3.23	3.49
5	I understand the environmental problems more with the activity.	3.17	3.47	3.27	3.65	3.57
6	I am not interested in the environmental problems given in the activities.	3.24	3.52	3.34	3.54	3.45
7	I have more faith in the environmental problems with the activities.	3.66	3.82	3.29	3.43	3.65
8	I have more opinions on the solution of environmental problems based on the discussions at of the activities.	3.14	3.41	3.37	3.61	3.22
9	I couldn't understand a lot from the activities.	3.66	3.54	3.28	3.17	3.42
10	I had a better chance to communicate with our teacher about the activities.	3.29	3.25	3.66	3.49	3.55
11	I found the discussions during the activities boring.	3.17	3.47	3.56	3.43	3.56
12	The activities in the chapter are taught in a similar way to the other chapters.	3.56	3.24	3.41	3.29	3.66
13	The evaluations in the activities were good.	3.22	3.49	3.66	3.19	3.49
14	The topics that I saw in this chapter made me like the environmental education lesson more.	3.42	3.49	3.26	3.33	3.51
15	I haven't used the information about the environment in my daily life that much.	3.53	3.42	3.19	3.34	3.47
16	Such activities made the environmental education lesson quite boring.	3.22	3.37	3.51	3.49	3.66
17	I want the environmental education lesson to be always taught like this.	3.23	3.41	3.34	3.54	3.55
18	I can use the information that I learnt in the lesson to discuss such matters.	3.19	3.14	3.25	3.51	3.43
19	The activities during the lesson made the class environment more enjoyable.	3.43	3.21	3.31	3.58	3.66
20	I started to get along with my friends better through the activities in the environmental education lesson.	3.56	3.29	3.17	3.26	3.51
21	What I learnt from the environmental education lesson eliminated the unclear points for me.	3.17	3.47	3.63	3.33	3.39
22	With the environmental education lesson, I learnt that nature protects itself against humans.	3.21	3.33	3.55	3.29	3.55

According to **Table 5** showing the arithmetic average of environmental activities assessment surveys, the average of the ÇB chapter is between 3.17 and 3.66, that of the EK chapter between 3.21 and 3.82; that of the BH chapter between 3.17 and 3.66, that of the ÇO chapter between 3.17 and 3.65 and lastly that of the Çİ chapter between 3.22 and 3.66.

## DISCUSSION AND CONCLUSION

After the evaluation of the preliminary and final test results of the achievement tests administered to the sample group, a t-test was performed to identify whether or not the difference between the preliminary and final tests were statistically significant. There was a statistical significant difference between the preliminary and final test scores of the 6<sup>th</sup> and 7<sup>th</sup> grade students in favour of final test: Environmental Awareness Chapter,  $p = .000$ ,  $p < 0.05$ ), Ecosystem,  $p = .003$ ,  $p < 0.05$ ); Plants and Animals,  $p = .005$ ,  $p < 0.05$ ); Environmental Events,  $p = .001$ ,  $p < 0.05$ ); Environment and Humans,  $p = .003$ ,  $p < 0.05$ .

Following the assessment of the preliminary and final tests in relation with the achievement test applied on the students for the "Environmental Awareness Chapter", the statistically significant difference between the preliminary and final test scores of students in favour of the final test indicated that the modular curriculum leads to an increase in the academic success of students and the clarity of related outcomes of the modular curriculum for the students

contributed to the learning process of concepts and enhancement of academic success. The designed curriculum created a discussion environment for students and led them to organize discussion activities on the concepts. This discussion can be considered as a contribution of the students to discuss the current issues and help them to reach solutions. Therefore, the modular curriculum enabled the effective learning environment given in the literature and thus would improve in the future. The environment, environmental pollution, waste and prevention of environmental pollution are the topics on the agenda. The modular curriculum emphasizes the issues of recycling and waste; gives sufficient time to learn such concepts and leads to a positive change in the conceptual understanding and academic success of students by constituting unique outcomes in relation with recycling. Such a situation can be interpreted as a separate environmental education lesson that is effective in improving success in terms of conceptual understanding and academic success (Akyol & Kahyaoğlu, 2012). Since the activities are in compliance with the 5E learning model, the students are able to recycle paper and understand the concept of recycling in addition to facilitating better understanding of concepts conducted under “*the problem solving*” step (Özsevgeç & Artun, 2012b; Şahin, 2010).

Following the assessment of the preliminary and final tests in relation to the achievement test administered to the students for the “*Ecosystem Chapter*”, the statistically significant difference between the preliminary and final test scores of students in favour of the final test indicated that the modular curriculum leads an increase in the academic success of students using the modular curriculum. The modular curriculum and studies of Ramadoss and Poyyamoli (2011) and Lindemann-Matthies, P. (2002) regarding the importance of bio-diversity and its provision within a curriculum have similarities. The designed curriculum provides bio-diversity under a curriculum together with the outcomes and activities, which might find solutions for the deficiencies of related studies and improve the conceptual understanding of students. Since the modular curriculum allows students to merge different activities and correlate the concepts, it is considered as contributing to the realization of learning by bringing the mental functions of students to the high levels. The efficient use of the 5E learning model can be interpreted as improving the conceptual understanding (Artun & Coştu, 2013; Gül & Yeşilyurt, 2001). On the other hand, another feature of the designed curriculum is that the activities are suitable for students and they are able to understand the concepts themselves. The modular curriculum enables the use of alternative teaching methods and techniques that are more efficient in environmental education rather than the traditional teaching methods (Coca, 2013; Lindemann-Matthies, 2002; Manolas & Leal Filho, 2011; Ramadoss & Poyyamoli, 2011). The longer and more comprehensive learning environment provided to the students through the modular curriculum allows students to improve their critical thinking skills and contributes in finding solutions to the problems. Therefore, a good learning environment of students have a major place in learning concepts (Bukova-Güzel, 2008; Tafrova-Grigороva, Boiadjieva, Emilov, & Kirova, 2012).

Following the assessment of preliminary and final tests in relation with the achievement test administered to the students for the “*Environmental Events Chapter*”, the statistically significant difference between the preliminary and final test scores of students in favour of the final test indicated that the modular curriculum leads an increase in the academic success of students in terms of the Environmental Events Chapter. The study of Thornber, Stanisstreet, and Boyes (1999) stated that the knowledge of students in relation to air pollution and damages caused by air pollution, and such a concept must have a major place in the curriculum. The modular curriculum widely covers the outcomes of air pollutions while correlating the events of air pollutions and elaborating the main reasons of air pollution, which allows students to understand the air pollution concepts better. Additionally, the designed curriculum provides information about the other types of pollution in addition to air pollution that might be a reason of for improvement in the conceptual understanding as concepts complement each other and ensure correlation. This can be interpreted that the modular curriculum is significant for learning about the concept of air pollution. The activities of the modular curriculum led to group discussions and changes in the perspective of students towards environmental events. Such circumstance can be interpreted as allowing questioning concepts and improving critical thinking. The modular curriculum allowed students to see the environmental events in more concrete ways through its activities and materials (Dağ & Kırıkaya, 2012).

Following the assessment of the preliminary and final tests in relation to the achievement test that was administered to the students for the “*Plants and Animals Chapter*”, there was a statistically significant difference between the preliminary and final test scores in favour of the final test. In consideration of the answers given by the students at the last interview, the majority were mainly about the solution to problems in relation to plants and animals and taking measures, which were both covered in a limited number of references in the literature (Atasoy & Ertürk, 2008; Seçgin, Yalvaç, & Çetin, 2010).

Following the assessment of the preliminary and final tests in relation with to the achievement test that was administered to the students for the “*Environment and Humans Chapter*”, the statistically significant difference between the preliminary and final test scores of students in favour of the final test indicated that the modular curriculum leads to an increase in the academic success of students. The relation between the environment and humans is the least known subjects of environmental education. While there are almost no studies on this matter

in the literature, the level of conceptual understanding is also not clearly known in terms of the relation between the environment and humans. The designed curriculum covers studies regarding such concepts and eliminates any deficiencies. It can be explicitly noted that the students must know such topics, yet they don't have sufficient knowledge. Due to the nature of the designed curriculum, it covers the relation between the environment and humans, which is not included in other curricula. It also supports the problem solving process to the problems such as people causing environmental deterioration and allows the implementation of solutions through the use of knowledge.

Lastly, the results reflected that there was a positive change in the conceptual understanding and academic success among students. The students started to understand the concepts related with environmental education more easily and much more clearly. The students now gave more consideration to environmental problems. The modular curriculum allowed students to learn much detailed information about the concepts of environmental education and improved their critical thinking skills through the provision of group activities allowing the discussion of environmental education concepts, which were taught in the modular curriculum.

The outcomes of the modular curriculum was that students liked environmental education and that the curriculum implemented student oriented practices, which positively changed the environmental attitudes of students, provided sufficient time for the improvement of positive environmental attitudes, contributed to the improvement of environmental attitudes through providing a multi learning environment with reading texts and posters related with environmental education that improved the environmental awareness of students and positively changed their environmental attitudes. Similarly, Akkor and Gündüz (2017) offers to be focusing rather than on the concern of the students with regard to future environmental problems. The importance of the individual studies should be pointed out for the resolution of the environmental problems, and the students should be encouraged in this direction.

The aim of this study was to identify "Is there any significant effect of the designed environmental education modular curriculum on the environmental attitudes of 6<sup>th</sup> and 7<sup>th</sup> grade students from the schools in the North Cyprus?" The environmental education attitude scale was used in the study. The objective in using such assessment tools was to reflect the changes in the environmental attitudes of students in detail. After the evaluation of the preliminary and final test results of the environmental education attitude scale a t-test was performed to identify whether or not the difference between the preliminary and final tests were statistically significant. There is no statistically significant difference ( $p = .007$ ,  $p > 0.05$ ) between the preliminary and final test scores of students in favour of final test.

In consideration of the high total scores from the scenarios in relation to the problem solving skills of students, the designed modular curriculum created a positive contribution on the improvement of problem solving skills of students. Since the activities of the curriculum were in accordance with the 5E learning model and to allow the improvement of research skills among students; hence it is not effective for the students to understand the existing environmental problems around them and to attract as well as lead the students in problem solving through the developed scenarios.

## REFERENCES

- Akkor, Ö., & Gündüz, Ş. (2017). The study of university students' awareness and attitude towards environmental education in Northern Cyprus. *Eurasia Journal of Mathematics, Science and Technology Education*, 14(3), 1057-1062. <https://doi.org/10.12973/ejmste/81366>
- Akyol, B., & Kahyaoğlu, H. (2012). İlköğretim ikinci kademe öğrencilerinin çevre bilgi düzeyleri üzerine bir çalışma: Niğde örneği. *X. Ulusal Fen Bilimleri ve Matematik Eğitimi Kongresi*, 27-30 June, Niğde.
- Artun, H., & Coştu, B. (2013). Effect of the 5E model on prospective teachers' conceptual understanding of diffusion and osmosis: A mixed method approach. *Journal of Science Education and Technology*, 22(1), 1-10. <https://doi.org/10.1007/s10956-012-9371-2>
- Atasoy, E., & Ertürk, H. (2008). İlköğretim öğrencilerinin çevresel tutum ve çevre bilgisi üzerine bir alan araştırması. *Erzincan Eğitim Fakültesi Dergisi*, 10(1), 105-122.
- Balgopal, M. M., & Wallace, A. M. (2009). Decisions and dilemmas: Using writing to learn activities to increase ecological literacy. *The Journal of Environmental Education*, 40(3), 13-26. <https://doi.org/10.3200/JOEE.40.3.13-26>
- Bukova-Güzel, E. (2008). Yapılandırmacı öğrenme yaklaşımının matematik öğretmen adaylarının matematiksel düşünme süreçlerine olan etkisi. *e-Journal of New World Sciences Academy*, 3(4), 678-688.
- Büyükoztürk, Ş., Çakmak, E. K., Akgün, Ö. E., Karadeniz, Ş., & Demirel, F. (2017). Bilimsel araştırma yöntemleri. *Pegem Atf İndeksi*, 1-360. <https://doi.org/10.14527/9789944919289>

- Bybee, J. W., & Landes, N. M. (1988). The biological sciences curriculum study (BSCS). *Science and Children*, 25(8), 36-37.
- Çepni, S. (2010). *Araştırma ve Proje Çalışmalarına Giriş*. Genişletilmiş 5. Baskı, Üçyol Kültür Merkezi, Trabzon.
- Coca, D. M. (2013). The influence of teaching methodologies in the learning of thermodynamics in secondary education. *Journal of Baltic Science Education*, 12(1), 59-72.
- Cohen, L., & Manion, L. (1989). *Research methods in education* (3<sup>rd</sup> Ed.), New York, NY: Routledge Publication, New York.
- Dağ, F., & Kırıkkaya, E.B. (2012). 8. sınıf doğal süreçler ünitesi için web tabanlı öğretim materyali hazırlığı: Farklı alan uzmanlarının materyal hakkındaki görüşleri. *e-Journal of New World Sciences Academy*, 7(1), 212-229.
- Darçın, E. S., Bozkurt, O., Hamalosmanoğlu, M., & Köse, S. (2006). Determination of elementary students' level of knowledge and misconceptions about greenhouse effect. *International Journal of Environmental and Science Education*, 1(2), 104-115.
- Ekiz, D. (2003). *Eğitimde araştırma yöntem ve metodlarına giriş: Nitel, nicel ve eleştirel kuram metodolojileri*. Anı Yayıncılık.
- Ergin, H., & Okutmuş, E. (2007). Çevre Muhasebesi: Çevre Maliyetleri ve Çevre Raporlaması. *Yönetim Bilimleri Dergisi*, 5(1), 33-45.
- Ergin, H., & Okutmuş, E. (2007). Çevre Muhasebesi: Çevre Maliyetleri ve Çevre Raporlaması. *Yönetim Bilimleri Dergisi*, 5(1), 33-45.
- Gül, Ş., & Yeşilyurt, S. (2011). Yapılandırmacı Öğrenme Yaklaşımına Dayalı Bir Ders Yazılımının Hazırlanması ve Değerlendirilmesi. *Cukurova University Faculty of Education Journal*, 40(1), 19-36.
- Lindemann-Matthies, P. (2002). The influence of an educational program on children's perception of biodiversity. *The Journal of Environmental Education*, 33(2), 22-31. <https://doi.org/10.1080/00958960209600805>
- Manolas, E., & Leal Filho, W. (2011). The use of cooperative learning in dispelling student misconceptions on climate change. *Journal of Baltic Science Education*, 10(3), 168-182.
- Özsevgeç, T. (2007). *Determining effectiveness of guided materials about force and motion unit based on the 5E model for elementary students* (Unpublished PhD Thesis). Karadeniz Technical University.
- Özsevgeç, T., & Artun, H. (2012). İnsan Ve Çevre Ünitesinin" öğretiminde fen ve teknoloji öğretmenlerinin karşılaştıkları zorluklar. *X. Ulusal Fen Bilimleri ve Matematik Eğitimi Kongresi*, 27-30 June, Niğde.
- Ramadoss, A., & Poyyamoli, G. (2010). Biodiversity conservation through environmental education for sustainable development-a case study from Puducherry. *International Electronic Journal of Environmental Education*, 1(2), 97-111.
- Şahin, Ç. (2010). *İlköğretim 8. sınıf "kuvvet ve hareket" ünitesinde "zenginleştirilmiş 5e öğretim modeli"ne göre rehber materyaller tasarlanması, uygulanması ve değerlendirilmesi* (Doctoral Thesis), KTÜ, Fen Bilimleri Enstitüsü, Trabzon.
- Sarıay, M. (2008). *Ortaöğretim fizik dersi itme ve momentum konusu öğretim programını geliştirme üzerine bir çalışma* (Masters Thesis).
- Seçgin, F., Yalvaç, G., & Çetin, T. (2010). İlköğretim 8. sınıf öğrencilerinin karikatürler aracılığıyla çevre sorunlarına ilişkin algıları. *In International Conference on New Trends in Education and Their Implications*, 11(13), 391-398.
- Şimşekli, Y. (2001). Bursa'da "uygulamalı çevre eğitimi" projesine seçilen okullarda yapılan etkinliklerin okul yöneticisi ve görevli öğretmenlerin katkısı yönünden değerlendirilmesi. *Uludağ Üniversitesi Eğitim Fakültesi Dergisi*, 14(1), 73-84.
- Stamp, N., & O'Brien, T. (2005). GK-12 Partnership: A model to advance change in science education. *BioScience*, 55(1), 70-77. [https://doi.org/10.1641/0006-3568\(2005\)055\[0070:GPAMTA\]2.0.CO;2](https://doi.org/10.1641/0006-3568(2005)055[0070:GPAMTA]2.0.CO;2)
- Tafrova-Grigorova, A., Boiadjeva, E., Emilov, I., & Kirova, M. (2012). Science teachers' attitudes towards constructivist environment: A Bulgarian case. *Journal of Baltic Science Education*, 11(2), 184-193.
- Tas, G., & Seçken, N. (2009). İlköğretimde "Maddenin İçyapısına Yolculuk" Konusunun Öğretiminde Yapılandırmacı Yaklaşımın Etkisi. *Education Sciences*, 4(2), 520-533.
- Taycı, F., & Uysal, F. (2009). Çorlu'da birinci ve ikinci kademe ilköğretim öğrencilerine çevre eğitimi konusunda uygulanan anket çalışması. *Fen, sosyal ve çevre eğitiminde son gelişmeler sempozyumu*, 18-20.
- Thorner, J., Stanisstreet, M., & Boyes, E. (1999). School students' ideas about air pollution: Hindrance or help for learning? *Journal of Science Education and Technology*, 8(1), 67-73. <https://doi.org/10.1023/A:1009481521719>
- Uzun, N., & Sağlam, N. (2006). Orta öğretim öğrencileri için çevresel tutum ölçeği geliştirme ve geçerliliği. *Hacettepe Üniversitesi Eğitim Fakültesi Dergisi*, 30(30).

- Wilder, M., & Shuttleworth, P. (2005). Cell inquiry: A 5E learning cycle lesson. *Science Activities: Classroom Projects and Curriculum Ideas*, 41(4), 37-43. <https://doi.org/10.3200/SATS.41.4.37-43>
- Yıldırım, A. (1996). Disiplinlerarası öğretim kavramı ve programlar açısından doğurduğu sonuçlar. *Hacettepe Üniversitesi Eğitim Fakültesi Dergisi*, 12(12).

**<http://www.ejmste.com>**



For print copies of this issue or articles please send an e-mail to:

[print@modestum.co.uk](mailto:print@modestum.co.uk)



# Understanding Students Ideas about Animal Classification

Zofia Anna Chyleńska <sup>1\*</sup>, Eliza Rybska <sup>1</sup>

<sup>1</sup> Department of Nature Education and Conservation, Adam Mickiewicz University in Poznań, POLAND

Received 7 November 2017 • Revised 30 January 2018 • Accepted 3 February 2018

## ABSTRACT

Classification is the arrangement of objects such as e.g. organisms, ideas, or information into groups. Its purpose is to make things easier to identify, describe, organize, find and study. Although classification itself is meant to help people to unify or clarify objects they are interested in, publications show that students might find it difficult to classify plants, animals and other organisms. The goal of the study has been to investigate Polish students' conceptions and attitudes towards animal classification and reveal the gaps between these and current scientific knowledge. The study has been conducted by surveys and in-depth interviews of 34 pupils, from primary schools. The research shows that students have similar conceptions about animal classification and also that children see the purpose behind animal classification but find it hard to apply in practice. Moreover, students were using different factors to distinguish animal classes from the ones used by scientific community. For example, they differentiated animals on the basis of: food they consume, respiratory system and utility for humans. Authors suggest that more stress should be put on these aspects during designing lessons about animal classification.

**Keywords:** animal classification, primary student's conceptions

## INTRODUCTION

### Cultural Influences

From an early age children try to differentiate animate objects from inanimate ones so they could create their own picture of nature (Reiss & Tunnicliffe, 1999). According to human the nature theory, the way of classifying the world which surrounds us is similar for all the humankind, and sometimes it might be naive and inaccurate, regardless of whether someone is an adult or a child (Linquist, Machery, Griffiths, & Stotz, 2011). Moreover, humans like to categorize and create lists of very different things and elements, no matter if they are realistic or not, as noticed by Eco (2009). However, children's concepts about classification of the world might be a problem even at the elementary level, when differentiating what a living organism is and what is not (Bell, 1981). In Japan, children tend to think about stones as living creature – partially because according to some Japanese beliefs, stones can have a soul (Inagaki & Hatano, 1993). Also, defining what an animal is, can be difficult for students. Trowbridge and Mintzes (1988) while studying this issue, showed that for many pupils, the only known animals are their own pets – e.g. dogs, cats (mostly mammals). Such findings can be linked with earlier works of Barrow (2002) who noted that the classification of insects and their life cycles is a major challenge for students. He demonstrated that, when talking about insects without the context of insects' habitat, respondents were unable to give the correct answer about their taxonomy or ecology. Furthermore, Kattman (2001) showed that when children know the animals and rules how to classify them – they still prefer to do it by their own characteristics such as locomotion or environment.

### Psychological Perspective

From the work of Gelman (2009) it is known that children are essentialists and will look at the idea of animals from the perspective of their essence. Although there have been no research relating to Polish children at this age. One of them is the work of Rybska, Tunnicliffe and Sajkowska, who investigated children ideas about internal

#### Contribution of this paper to the literature

- Connects human nature framework with the topic of animal classification, which could lead to development of tools that would make it more accessible in the classroom.
- Gives us deeper insight into attributes used innately by children to classify animals on which teachers should focus, while teaching about animal classification.
- Presents the gap between adults' and children's perception of animal classification.

anatomy of trees (2017), snails (2014) and earthworms (2015). What is interesting in connection with Gelman (2009) work is that as children draw their representation of these living organism and their internal structure, they often do not draw internal organs, but their essence – for example their usefulness – home for animals inside tree trunk (Rybska et al., 2017), or furniture in snails shell (Rybska et al., 2014).

In its nature, the classification is similar to the process described by psychologists and called categorization. People do this in their minds, by building concepts and trying to find similarity to the prototype or expanding the network of the concept. Rosch, Mervis, Gray, Johnson, and Boyes-Braem (1976) has distinguished three levels of categories into which people classify objects in their surroundings - *superordinate*, *basic* and *subordinate*. Basic objects are the most inclusive categories whose members: (a) possess significant numbers of attributes in common, (b) have motor programs which are similar to one another, (c) have similar shapes, and (d) can be identified by average shapes of members of the class (Rosch et al., 1976). Usually objects that belong to this category are perceptual, and classification of an object to the basic category does not involve lots of cognitive effort. Superordinate categories are located at the top of a categorization processes. They show a high degree of generality and offer abstract, non - perceptual information (that is why they are called a category wide attribute). They show a low degree of inclusion and include basic level categories. Subordinate level categories are located at the bottom of the folk taxonomy. They are very detailed, show particularity of the objects and a low degree of class inclusion. They have clearly recognizable, identifiable and highly detailed characters and numerous individuating specific features.

According to Trzebinski (1985), based on Rosch et al.'s research one might conclude that the basic concept consists of two elements - a prototype and a set of representations of many examples that belong to the same concept. The collection of represents possesses a different degree of similarity to the prototype, and the smaller the similarity is, the weaker the relation of "being a referent" between the basic concept and the represented object. Taylor (1989) states that "the clear boundaries of natural categories depend on both the way the world is and what we know about it." Categorizations of concepts are culturally conditioned. Both concept and category, despite their core character, are dynamic beings that extend their reach. It would appear that not only the selection of terms used during educational events is important, but also the educational environment created by the teacher, the choice of didactic agents affecting the body of students and the ways of contact, cognition and experience of the means.

Concepts, as well as categorization of core characteristics, are dynamic beings with expanding ranges. From this perspective, we are trying to find the attributes used by students to make categorization such as biological classification, in order to find a prototype objects that are important for them in the process. For example, if we want to help students to create the concept of an amphibian, primarily we should let them observe and experience an animal, which is most commonly collocated with the concept of an amphibian, for e.g. a frog - with all of the specific details for this group: delicate and thin skin with slime, specific and primitive motor skills on the land, hyperventilation with help of the mouth cavity (buccopharyngeal cavity, buccal pump), as they do not have chest, reproduction dependent on the water etc. By this example, students construct their basic concept. Next, we can introduce them less typical animals like common newt - which may have similar characteristics as frog but is a little bit different - have a tail and live mostly in the water. In the end, fire salamander, as the most untypically looking Polish amphibian should be presented this way, students might be able to create abstract construct of the group of amphibians - which is the superordinate level (Rosch et al., 1976).

### Polish Educational System

In Polish education system, the idea of animal classification, other than from essentialist and utilitarian perspective, is introduced in primary school as an adaptation of specific species to the environment, without special focus on the idea of animal classification, the rules which apply, the meaning of each range and taxon etc. After the recent reform, introduced this year, students will be familiarized with the idea of animal classification at similar age of eleven. Equally, pre and post reform concept of animal classification is treated similarly, and children encounter this concept for the first time during their formal education.

Taxonomy, as a branch of biology, is important as it shows interconnections between groups of organisms. But to know something and therefore to understand its value, reasons and means to protect it, one has to be interested

in the topic. Accordingly, the textbooks should contain representations of animals typical and native for a given country and these animals should also be presented by a teacher during lessons. However, due to their appeal, the photographs in textbooks more frequently show exotic and more colorful species, frequently omitting visually attractive native ones. Authors, in their research, show that teachers prefer attractiveness of the textbooks more than their essential correctness (Sajkowska & Rybska, 2014). Other publication on the matter of protecting amphibians and reptiles touch on them only from the perspective of protective actions such as cleaning environment for living animals, species inventories or safe transfer of individual through communication areas during mating season (Lewandowska, 2013; Zielinski, 2007). One of the few publications in Poland, which deals with protecting amphibians through the process of education, is work of Kolenda (2011) who proposes didactical intervention in a small city in Poland and after that, organizes cyclical annual actions of cleaning amphibians' environment (Kolenda, 2014).

### Human Nature - Framework

The animal classification, which appears in folk biology, is usually very complex, but in general, we can distinguish two parts. The first part, corresponding with human nature, is a classification based on describing the surrounding world (Linguist et al., 2011). In this case, the description of an animal is very accurate as in the past centuries, humans were closer to the nature, and plants' and animals' morphology or behavior were quite commonly known. The second part is mainly tentative as it consists of various beliefs and superstitions. In this case, humans tend to anthropomorphize animals attributing them some human characteristics. It is popular to say that someone is hard-working as an ant or a bee, or strong as an oak, brave like a lion, or sensitive as mimosa, or even when the name of an animal is synonymous to some behavior as in the case of chicken (Kean, 2012; Lakoff, 1993; Linguist et al., 2011).

Since children usually have their own (mental) version of folk biology, the whole concepts become even more inquiring (Atran, 1998; Medin & Atran, 1999). Children much more often ascribe human template to plants and animals (Gould, 1977). In 1977, Gould presented the idea that ontogeny of children up to 10 years old and their development of concepts mimic cultural evolution of humans, where the spiritual elements and believes in nature phenomenon are gradually getting replaced by scientific discoveries through the centuries (in that case of humans as a species), or gained through the education (in case of children).

Previous researches in the field of animal classification was conducted in New Zealand (Bell, 1981), USA (Trowbridge & Mintzes, 1988), Slovakia (Prokop & Tunnicliffe, 2008) or Taiwan (Yen, Yao & Chiu, 2004), however none of these papers focus on children from central European farmland landscape, such as Poland. In Balmford, Clegg, Coulson, and Taylor (2002) students from Great Britain were given the task to classify both animals present in their neighborhood and Pokemons (fictional creatures from popular children's cartoon) into appropriate groups. Results show that students were more efficient in assigning Pokemons to appropriate groups and classes (as they were classified in the cartoon) than in classifying animals present in their environment to appropriate classes. This example suggests that it is not impossible for young people to apply an artificial classification - they just have to be interested in it (Balmford et al., 2002). The topic has recently been reapproached by many researchers, thanks to an enormous popularity of the interactive mobile game *Pokemon Go*, and some researchers argue that this application, or other social media applications, such as Facebook, might increase outdoor movement of the youngest and may lead to an increasing number of encounters with some of the species - like hedgehogs (Dorward, Mittermeier, Sandbrook, & Spooner, 2016) or even to discovering new species (Skejo & Caballero, 2016). These attitudes could potentially be used for rising environmental awareness.

Nevertheless, among numerous investigations about animals and attitudes towards them, none of the researches was specifically focused on students' attitudes toward animal classification together with describing the attributes and the prototypes they find important or valid while classifying organisms. For example, Trowbridge and Mintzes (1988) widely investigated animal classification phenomena, but only focusing on students' conceptions about it, not considering the attitudes and whether students see the sense in the animal classification or not.

Following research has the goal to show the gap between scientific knowledge of animal classification and students' conceptions about it by asking open questions about the topic and usefulness of the animal classification for humans within a framework of human nature.

### METHODS

The instruction for the interviews were based on initial surveys carried out before by authors. The interviews/the surveys were conducted in 5 primary schools from the urban area in Poznan attended by pupils between 6 and 13 (K1-6) as suggested by (Bizzo & Caravita, 2012). The in-depth interviews were conducted in a separate room or in the corner of a classroom. A total number of 34 pupils were interviewed (one from K4 - 10yo,

seventeen from K5-av. 11yo, seventeen from K6-av. 12yo), 22 of them were girls and 13 were boys. All of them were summoned individually while they were engaged in their regular work for the interviews and teachers were asked to ensure that pupils of an equal range of abilities were interviewed (equal numbers at each age range classified by their teachers as 'above average', 'average' and 'below average').

What we would like to find out is whatever kids will ascribe the human-cultural classification to biological taxonomy. Therefore, the major problems addressed by the interviews were: 1) How do students understand animal classification - and if they see it as something connected more with physical or functional similarities and not the biological kinship? 2) What activities in the classroom, should we undertake to change found folk taxonomy into scientifically correct concepts? 3) Are students aware of the gap between their concepts and scientific knowledge about animal classification? To resolve these problems, and for the better understanding of students' concepts of animal classification, four major questions were asked to students in accordance with instructions without any prompts:

1. Do you like animals? Do you have any pets?
2. Is there any goal of animal classification? If there is, what is it?
3. What would happen if there were no animal classification? Their prediction of not having animal classification at all.
4. How would you classify animals? On the base of what predicament/attributes?

The first questions was asked to state students' attitudes toward animals - as Prokop and Tunnicliffe's (2010) work shows, having a pet, or liking one, might influence answers of students, and authors wanted to know if in the interviewed group, there are students who do not like animals, which might make results inconclusive.

Questions from two to four referred directly to students' knowledge and attitudes towards animal classification.

Moreover, we were interested in observing the differences in the students' answers in relation to their gender or age.

Pupils' answers were audio recorded. The questions were asked in predesigned order to each pupil. If the pupils did not understand any of the questions, researcher explained them in detail. Pupils were chosen from the class without any previous notice and consequently, they were not able to prepare themselves for the interviews. To motivate pupils, each of them received a verbal encouragement and a praise. In cited transcripts "R" means Researcher, "B" stands for boys, and "G" for a girls.

## Statistical Analysis

Recordings were analyzed by two researchers, whom has made content analysis and categorization of data. Data were implemented to Excel program separately for each student, and then were measured results of frequency in each category.

## RESULTS

Results are presented in order in which questions were asked in interviews.

1. *Do you like animals? Do you have any pets?*

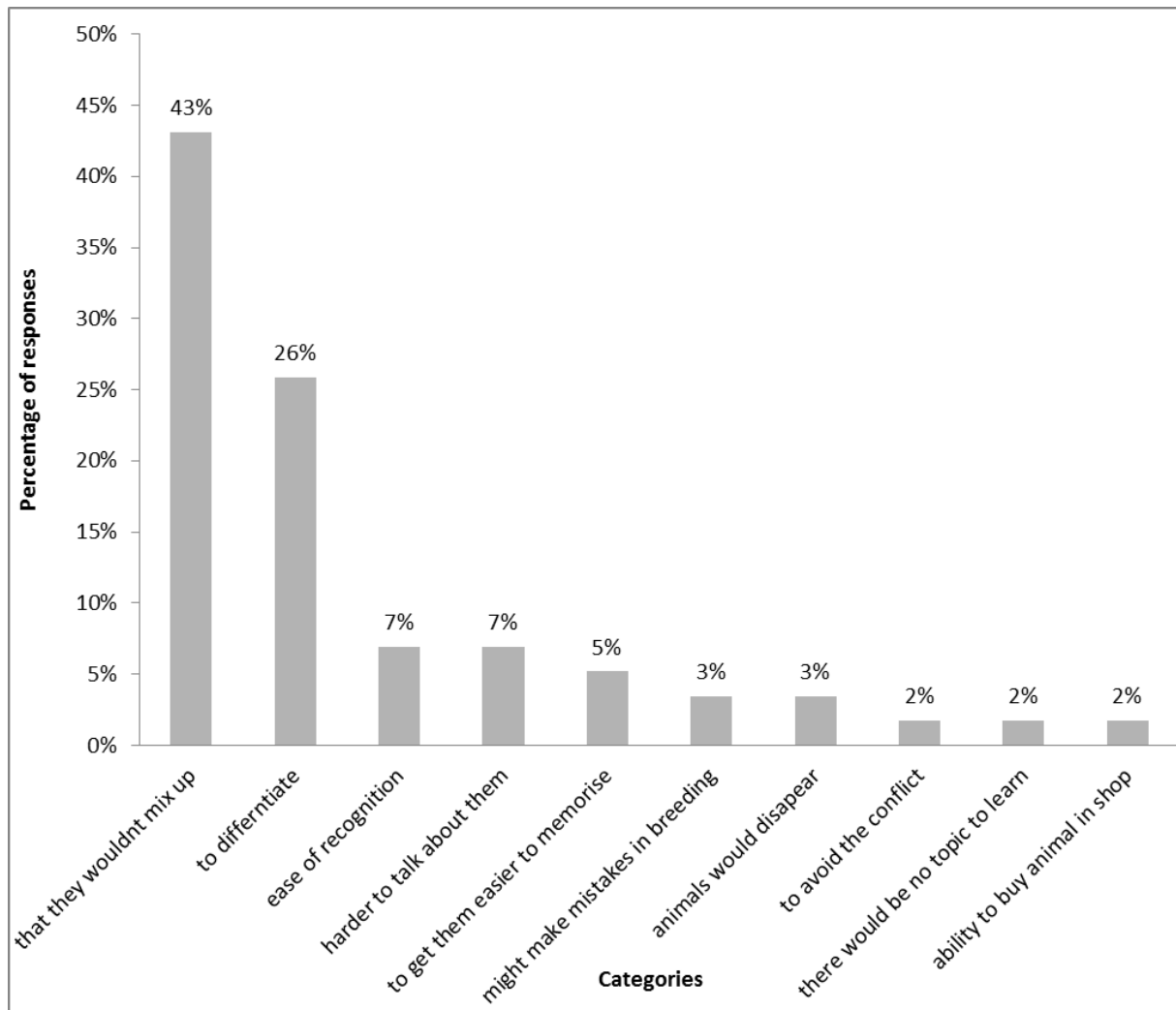
As a response to the first question, majority of respondents claimed that they liked animals (96%) and they owned one (82%). Most of them had a dog as a pet.

2. *Is there any goal of animal classification? If there is, what is it?*

In the response for the second question, all of the pupils claimed that animal classification was important (100% of respondents). But, when asked about the goal of animal classification and why we do it, the children's answers varied. About 60% of pupils claimed that the goal of animal classification was to differentiate animals from each other, rest of the respondents had no idea what the purpose was, but the question number three helped them to express themselves.

3. *What would happen if there weren't any animal classification? Their prediction of not having animal classification at all.*

The question number three in the survey was: what would happen if we removed animal classification? This, in contrast with question number two, encouraged students to use their imagination. All of the answers were divided on 10 categories. In the answers - one of the students claimed, that if we did not use animal classification, animals would not exist (2%- one boy), there would be mess and animals would get mixed up (43%), or that it would be hard to differentiate them (26%). Some students pointed out, that it would be hard to talk about animals without misunderstandings (7%) or recognize them just on the basis of morphological features (5%). Other ideas were also worth mentioning. There were pupils who said that in that situation it would not be easy to remember

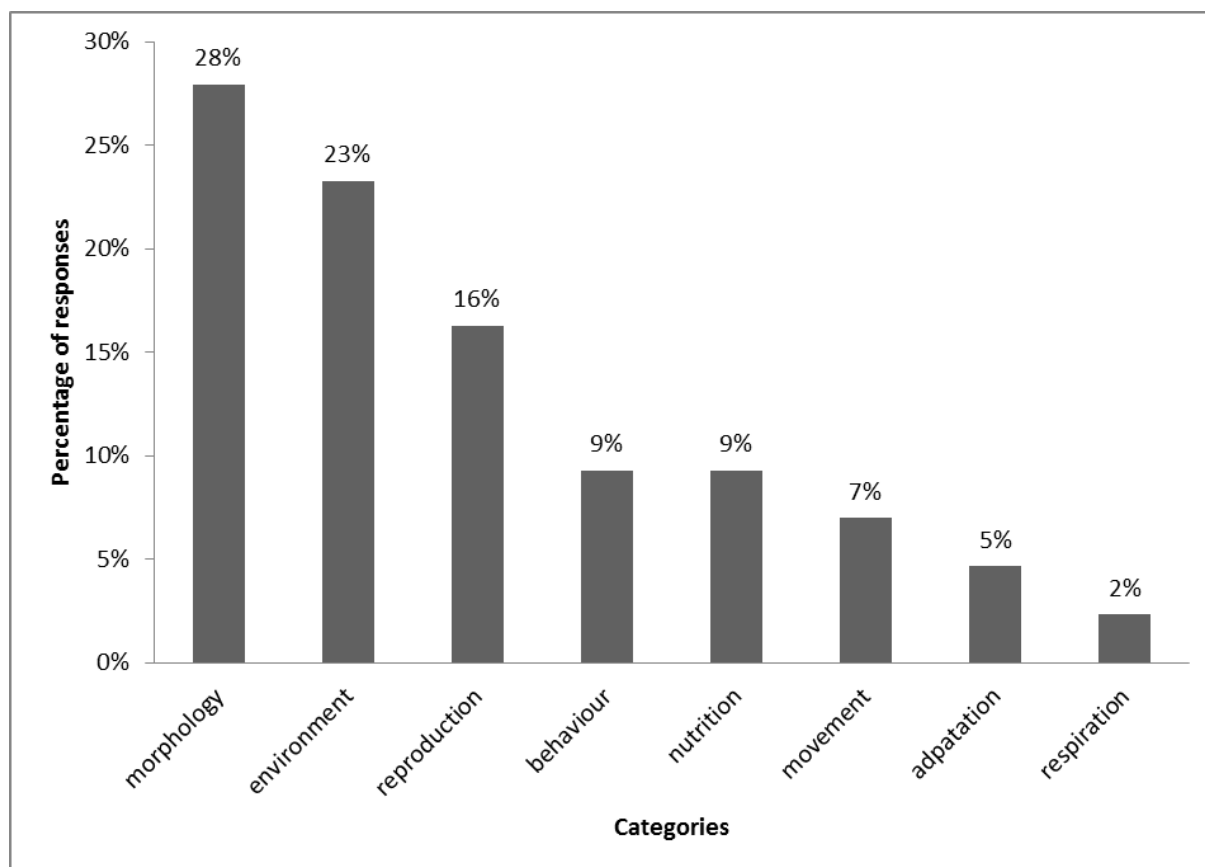


**Figure 1.** Percentage of responses to the question: Based on what category, can we classify animals? (N=34)

animals (5% - one girl and one boy) or that without animal classification all animals would be in one large uniform group and therefore, they might end up fighting each other (2% - one girl). In last two categories, students claimed more anthropocentric and practical ideas like - there wouldn't be any topic to learn (2%) or it would be hard to buy animals in the shop (2%). All of the answers are presented in [Figure 1](#).

4. *How would you classify animals? On the base of what predicament/attributes?*

Last question concerned the categories used in classification asking what key students would use to divide animals into different groups. The answers varied but we grouped them into 8 categories: morphology (28% of responses), environment (23% of responses), reproduction (16% of responses), behavior (9% of responses), ecology (mostly level in food chain) (9% of responses), type of locomotion (7% of responses), adaptation (5% of responses), organ of respiration (5% of responses). All of the answers are presented in [Figure 2](#).



**Figure 2.** Percentage of responses to the question: Base on what attributes, can we classify animals? (N=34)

**Table 1.** Differences between genders in claimed categories to classify animals (G – girls, B – boys, G% - percentage of answers for girls, B% - percentage of answers for boys)

Categories	FG	MB	FG%	MB%
Morphology	7	5	16.3%	11.6%
Environment	7	3	16.3%	7.0%
Reproduction	7	0	16.3%	0.0%
Behavior	3	1	7.0%	2.3%
Nutrition	4	0	9.3%	0.0%
Movement	2	1	4.7%	2.3%
Adaptation	1	1	2.3%	2.3%
Organ of respiration	0	1	0.0%	2.3%

There were differences between girls and boys - for example, in the category of morphology, 7 girls and 5 boys claimed that it was an important issue for animal classification, on the other hand, 7 girls said that reproduction was important to divide animals and none of the boys had similar ideas. All differences between gender are presented in [Table 1](#).

### Qualitative Analysis

The first question, which focused directly on the animal classification was the one which asked whatever students see any goal of animal classification. In this case, more boys (100%) than girls (93%) were convinced about that. When students started to explain their reasoning, one boy from 6 grade, said that:

“B: We differentiate animals, to recognize morphological features of an animal more easily.

R: What features?

B: Oh, for example what hide they have, where they live...”

However, that was the only one response which refer to significance of animal classification. Most of the boys claimed, that classification is based on animal anatomy:



"B: We differentiate animals because of how they look and what they have inside.

R: What do animals have inside?

B: Lungs, or heart...

R: And how can it be the key for classification?

B: Because, we can look at the different animals, check if they have hearts for example, and if they have something in common".

In this case, it can be observed, that this boy was more thorough with his observation and was aware of anatomy of animals and differences between them. This type of explanation was not observed in younger groups.

Another issue, raised only by boys, was adaptation, which was explained, for example, in such a way:

"B: I think, the classification of animals should be created on the basis of their adaptation,

R: Can you explain what adaptation is?

B: It is how they take care of themselves in the environment where they live.

R: And how can it be crucial for taxonomy?

B: Because if they are in the same environment, they can be close to each other, like family"

The idea of adaptation was quite interesting, although only one boy referred to this issue.

On the other hand, girls were more focused on such ideas as reproduction:

"G: We can differentiate animals, by the way how they reproduce and what the eggs look like,

R: Can you describe it?

G: Some animals have transparent eggs, some not, and some are born alive, without eggs."

In this response, a girl focused on a very important issue in differentiation of species, which is reproduction. These were very insightful, and in the future, this collection might be very useful to construct more complex concepts about animals.

Moreover, two girls were focused on the way how animals move:

"G: Animals move differently, snakes can wriggle and others can run,

R: What others?

G: Others, such as horses.

R: And beside horses?

G: There are frogs, which jump or birds which fly."

From this conversation, an assumption can be made, that girl claims snakes cannot run, which is correct. She also assigns the right kind of movement to other animals.

One of the girls, puts stress on utility of the animals for humans:

"G: Animals can be differentiated because of the use for humans. For example cows for milk or chickens for eggs".

This sentence showed that this girl had a pragmatic approach to animals, but also that she was aware that some food is provided by animals.

## Differences in Groups

The answers to first question shows differences between genders. The main difference that we observed, was students' explanation of the goal of animal classification. Girls had different ideas about it than boys. Authors divided students' answers into four categories: communication, kinship, key to classify and behavior.

The differences between genders were also observed in the answers to the second question. Majority of the boys (with the exception of two of them) responded that without animal classification there would be a disorder. On the other hand, girls had more varied replies. More girls than boys claimed that without classification it would be harder to memorize the animals, the lack of classification can lead to a conflict between animals, or that the animals would simply vanish. This result might show that girls are more empathic than boys. One of the girls compared the outcome to mixing two different groups in schools - if we merged two classes, students would be not happy to interact with some girls and boys from the outside of their class. All the categories, with specific examples are presented in [Table 2](#).

**Table 2.** Differences in categories in particular groups of students

Categories	Boys	Girls
Communication -		Different animals from different groups might fight with each other
Kinship	adaptation and origin is important in animal classification	animal kinship based on similarity of their external appearance
Key to classify	environment, anatomy, adaptation and respiration.	differentiation, reproduction, movement and food
Behavior	Animals despite being in the same group do not interact with each other	Animals in the same groups interact with each other, if we mix animals from different groups, they will be mainly exposed to negative consequences

## DISCUSSION

Our research shows that students were interested in animals and at the same time they failed to define animal classification scientifically. Having that in mind, researchers should look at other factors which might influence these results such as: social context, motivation or utilitarianism.

An important factor in the acquisition of information should be its social context. It is significant to draw attention to the conflict between the knowledge passed on us, for example, by parents and society, and scientific knowledge, which is given to us by teachers and textbooks (Mji & Makgato, 2006). Often, information provided by media, parents or textbooks, can be conflicted with scientific knowledge and leads to students' misconceptions (Barrow, 2002; Gericke, 2009; Sajkowska & Rybska, 2014). All of the above mentioned papers agreed that the motivation and interests of students is what we should be focused on. In our study, majority of the students declared their interests in animals and even owned some pets. In researched group, there was only one student who declared that he did not like animals and did not have any interests in them. To analyze how their interest influence their ideas towards animal classification further research should be conducted in a group with lower interests in animals.

The other factor which may have influence is motivation of students towards animal classification. Despite the age, humans - children and adults - have to see the purpose of their actions. When we are assigned to the task which, in our opinion has no goal, we are not motivated to do it, and also information gained in this way (after learning to exam in the subject which is useless for us) will be forgotten in a very short time (Rabinowitz & Vastag, 2012). And only when students are interested in something, gained knowledge will remain in their memory and will be used by them. Also, some of previously published works, had concluded that the interests of students are what researchers and teachers should focus on (Arends & Kilcher, 2010; Doyle, 1977; Marsh & Roche, 1997).

Our results show that for students, the utilitarian approach is most important, as they were thinking about animal classification as a tool. For example, as presented in works of Balmford et al. (2002) and Dorward et al. (2017) about Pokemons, children are able to learn classification when they are interested and see the purpose, as they knew that water Pokemons can defeat fire Pokemons, and that their strength depends on how big and evolutionary advanced they are. This was similar in both papers that students knew how to classify and how to use the Pokemon. What is also in agreement with our results, is that students' answers were always human centered - as they also referred how they can use animal classification for their purposes. It was evident, especially in question concerning what would happen without animal classification, as the answers were "It would be harder to learn" or "we couldn't divide them" or "there would be a mess". All of the respondents failed to notice the use of the classification for the research and protection of animals. But this result is not unexpected as it is linked with human nature theory, where human is in the center of everything. This is an important implication for researchers and teachers how to turn attention of students towards different aspects of classification and present them with a more holistic ecological view. In this way, we could teach them to think not only from human perspective but also from environmental perspective. The approach to build their own classification presented by Rosch and coworkers (1976) might be easier for students to understand. For example, if we want students to be able to create abstract and artificial concept of group of amphibians, teachers and textbooks might help with constructing a basic level by use of example of a frog with details and then gradually introduce more complicated native amphibians (like a newt or salamander), and allow them to create a superordinate level which is a general and abstract concept of higher taxonomy group. In our opinion, didactics should take these findings into consideration and try to apply them in their teaching processes.

While taking a closer look to gender differences, our results stays with agreement with Spelke (2005), that cognitive abilities of boys and girls (or male and female), from birth to maturity, do not support the claim that men have greater intrinsic aptitude for science. Both groups are able to learn scientific concepts at a superordinate level, they are able to use these concepts and possess common abilities to represent objects, numbers, language, and space

etc. What we can observe, are differences in so called cognitive profile, the example of which can be a more empathic approach in classification represented by girls than boys. Also, girls seems to pay bigger attention to the aspects of relations (eg. with the environment) while boys, in their explanations, are more focused on the organizational aspects. Baron-Cohen (2002) in their work suggest two kinds of approaches: empathizing and systematizing, and in our studies, girls presented more empathizing dimension then systematizing one, despite that, in their research, they did not tend to prescribe it to gender (Baron-Cohen, 2002; Zeyer, 2010). Developing future research in that direction is needed.

Nevertheless, looking at the aspects of taxonomy - one major question may arise - how should taxonomy be taught in order to put more pressure on its use in the environment research and study? For example, the modern taxonomy of animals is based on the phylogenetic origin and is often supported by genetic and morphological data, however, the research shows that students better memorize things connected with ecology or behavior (Cardak, 2009; Kattman, 2001). On the other hand, if a particular student learns about different animal taxons far away from wildlife, and their only source of information are textbooks, it is not surprising that their mental models are incomplete or just wrong (Bizzo, Monteiro, Lucas, & Bianco, 2012; Gericke, 2009; Sajkowska & Rybska, 2014). Therefore, it can be assumed that a lack of direct experience can be an important obstacle in understanding animal classifications. It was shown that contextual teaching is far more effective than teaching and learning without context (Ruiz-Mallen, Barraza, Bodenhorn, & Reyes-García, 2009). The obtained results help us to more deeply and holistically understand the idea of teaching about animal classification, by proving educational implications that it should be based on/and relate to students' ideas and interests about it.

## REFERENCES

- Arends, D., & Kilcher, A. (2010). *Teaching for student learning: Becoming an accomplished teacher*. London: Routledge.
- Atran, S. (1998). Folk biology and the anthropology of science: Cognitive universals and cultural particulars. *Behavioral and brain sciences*, 21(04), 547-569.
- Balmford, A., Clegg, L., Coulson, T., & Taylor, J. (2002). Why conservationists should heed Pokémon. *Science*, 295(5564), 2367-2367. <http://dx.doi.org/10.1017/S0140525X98001277>
- Baron-Cohen, S. (2002). The extreme male brain theory of autism. *Trends in cognitive sciences*, 6(6), 248-254. [http://dx.doi.org/10.1016/S1364-6613\(02\)01904-6](http://dx.doi.org/10.1016/S1364-6613(02)01904-6)
- Barrow, L. H. (2002). What do elementary students know about insects? *Journal of Elementary Science Education*, 53-60. <http://dx.doi.org/10.1007/BF03173848>
- Bell, B. F. (1981). When is an animal, not an animal? *Journal of Biological Education*, 15(3), 213-218. <http://dx.doi.org/10.1080/00219266.1981.9654381>
- Bizzo, N., & Caravita, S. (2012). School textbooks and updated sound science: narrowing the gap between classrooms and cutting edge science, *Journal of Biological Education*, 46(1), 1-3. <http://dx.doi.org/10.1080/00219266.2012.659112>
- Bizzo, N., Monteiro, P. H. N., Lucas, M. B., & Bianco, A. A. G. (2012). Corrected Science Textbooks and Snakebite Casualties in Brazil: 1993-2007. *Science Education International*, 23(3), 286-298.
- Cardak, O. (2009). Science students' misconceptions about birds. *Scientific Research and Essay*, 4(12), 1518-1522. Retrieved from [http://www.academicjournals.org/article/article1380633865\\_Cardak.pdf](http://www.academicjournals.org/article/article1380633865_Cardak.pdf)
- Dorward, L. J., Mittermeier, J. C., Sandbrook, C., & Spooner, F. (2017). Pokémon go: benefits, costs, and lessons for the conservation movement. *Conservation Letters*, 10(1), 160-165.
- Doyle, W. (1977). Paradigms for Research on Teacher Effectiveness. *Review of research in education*, 5(1), 163-198. <http://dx.doi.org/10.3102/0091732X005001163>
- Eco, U. (2009). *The Infinity of Lists* (A. McEwen, Trans.). USA: Rizzoli.
- Gelman, S. A. (2009). Essentialist reasoning about the biological world. *Neurobiology of "Umwelt"*, 7-16. [http://dx.doi.org/10.1007/978-3-540-85897-3\\_2](http://dx.doi.org/10.1007/978-3-540-85897-3_2)
- Gericke, N. (2009). *Science versus School-science: Multiple models in genetics-The depiction of gene function in upper secondary textbooks and its influence on students' understanding* (Doctoral dissertation), Karlstads universitet, Sweden. <http://dx.doi.org/10.5617/nordina.327>
- Gould, S. J. (1977). *Ontogeny and phylogeny*. Cambridge, Massachusetts, USA: Harvard University Press.
- Inagaki, K., & Hatano, G. (1993). Young children's understanding of the mind-body distinction. *Child development*, 1534-1549.

- Kattmann, U. (2001). Aquatics, Flyers, Creepers and Terrestrials – students' conceptions of animal classification, *Journal of Biological Education*, 35(3), 141-147.
- Kean, H. (2012). Challenges for Historians Writing Animal-Human History: What Is Really Enough? *Anthrozoös*, 25(sup1), 57-72.
- Kolenda, K. (2011). Amphibians in perypheral pound in Ostrów Wielkopolski - condition, threats, protection. In Latowski K, ed. *Problemy biologiczne współczesnego świata. Wydawnictwo Kontekst*, 123-127.
- Kolenda, K. (2014). Protecting local nature. *Edukacja Biologiczna i Środowiskowa*, (4/2014), 110-112.
- Lakoff, G. (1993). *The contemporary theory of metaphor*. Cambridge, UK: Cambridge University Press.
- Lewandowska, D. (2013). Amphibians protection in Turek forest district. *Studia i Materiały Centrum Edukacji Przyrodniczo-Leśnej*, 15(3[36]).
- Linguist, S., Machery, E., Griffiths, P. E., & Stotz, K. (2011). Exploring the folkbiological conception of human nature. *Philosophical Transactions of the Royal Society of London B: Biological Sciences*, 366(1563), 444-453. <http://dx.doi.org/10.1098/rstb.2010.0224>
- Marsh, H. W., & Roche, L. A. (1997). Making students' evaluations of teaching effectiveness effective: The critical issues of validity, bias, and utility. *American Psychologist*, 52(11), 1187. <http://dx.doi.org/10.1037/0003-066X.52.11.1187>
- Medin, D. L., & Atran, S. (1999). *Folkbiology*. Cambridge, UK: Mit Press.
- Mji, A., & Makgato, M. (2006). Factors associated with high school learners' poor performance: a spotlight on mathematics and physical science. *South African journal of education*, 26(2), 253-266.
- Prokop, P., & Tunnicliffe, S. D. (2008). "Disgusting" animals: Primary school children's attitudes and myths of bats and spiders. *Eurasia Journal of Mathematics, Science & Technology Education*, 4(2), 87-97. <http://dx.doi.org/10.12973/ejmste/75309>
- Prokop, P., & Tunnicliffe, S. D. (2010). Effects of having pets at home on children's attitudes toward popular and unpopular animals. *Anthrozoös*, 23(1), 21-35.
- Rabinowitz, J. D., & Vastag, L. (2012). Teaching the design principles of metabolism. *Nature chemical biology*, 8(6), 497-501. <http://dx.doi.org/10.1038/nchembio.969>
- Reiss, M. J., & Tunnicliffe, S. D. (1999). Conceptual development. *Journal of Biological Education*, 34(1), 13-16. <http://dx.doi.org/10.1080/00219266.1999.9655677>
- Rosch, E., Mervis, C. B., Gray, W. D., Johnson, D. M., & Boyes-Braem, P. (1976). Basic objects in natural categories. *Cognitive psychology*, 8(3), 382-439. [http://dx.doi.org/10.1016/0010-0285\(76\)90013-X](http://dx.doi.org/10.1016/0010-0285(76)90013-X)
- Ruiz-Mallen, I., Barraza, L., Bodenhorn, B., & Reyes-García, V. (2009). Evaluating the impact of an environmental education program: An empirical study in Mexico. *Environmental Education Research*, 15(3), 371-387.
- Rybska, E., Tunnicliffe, S. D., & Sajkowska, Z. A. (2014). Young children's ideas about snail internal anatomy. *Journal of Baltic Science Education*, 13(6), 828-838.
- Rybska, E., Tunnicliffe, S. D., & Sajkowska, Z. A. (2015). Children's ideas about internal structure of an earthworm. *Part 15 Strand 15 Early years science education ESERA 2015 Proceedings*, 2616-2626.
- Rybska, E., Tunnicliffe, S. D., & Sajkowska, Z. A. (2017). Children's ideas about the internal structure of trees: cross-age studies. *Journal of Biological Education*, 51(4), 375-390. <http://dx.doi.org/10.1080/00219266.2016.1257500>
- Sajkowska, Z. A., & Rybska, E. (2014). Does amphibians and reptiles are the same family? Herpetology in Polish textbooks. *Edukacja Biologiczna i Środowiskowa*, (s1), 92-98.
- Skejo, J. O. S. I. P., & Caballero, J. H. S. (2016). A hidden pygmy devil from the Philippines: *Arulenus miae* sp. nov. – a new species serendipitously discovered in an amateur Facebook post (Tetrigidae: Discotettiginae). *Zootaxa*, 4067(3), 383-393. <http://dx.doi.org/10.11646/zootaxa.4067.3.7>
- Spelke, E. S. (2005). Sex differences in intrinsic aptitude for mathematics and science?: a critical review. *American Psychologist*, 60(9), 950. <http://dx.doi.org/10.1037/0003-066X.60.9.950>
- Taylor, C. (1989). *Sources of the self: The making of the modern identity*. Cambridge, UK: Harvard University Press. <http://dx.doi.org/10.1515/9781400848393-060>
- Trowbridge, J. E., & Mintzes, J. J. (1988). Alternative conceptions in animal classification: A cross-age study. *Journal of Research in Science Teaching*, 25(7), 547-571.
- Trzebinski, J. (1985). Action-oriented representations of implicit personality theories. *Journal of Personality and social Psychology*, 48(5), 1266. <http://dx.doi.org/10.1037/0022-3514.48.5.1266>

- Yen, C. F., Yao, T. W., & Chiu, Y. C. (2004). Alternative conceptions in animal classification focusing on amphibians and reptiles: A cross-age study. *International Journal of Science and Mathematics Education*, 2(2), 159-174. <http://dx.doi.org/10.1007/s10763-004-1951-z>
- Zeyer, A. (2010). Motivation to learn science and cognitive style. *Eurasia Journal of Mathematics, Science & Technology Education*, 6(2), 121-128. <http://dx.doi.org/10.12973/ejmste/75233>
- Zielinski, P. (2007). Why it is important to protect firebelly toads *Bombina bombina* and their environments of living? *Studia i Materiały Centrum Edukacji Przyrodniczo-Leśnej*, 9(2-3 [16] cz. 2).

**<http://www.ejmste.com>**



<http://www.ejmste.com>



<https://twitter.com/ejmste>



<https://www.facebook.com/ejmste>



<http://modestum.co.uk/>



[publications@modestum.co.uk](mailto:publications@modestum.co.uk)



# The Effects of Creative Drama Teaching Methods on Academic Success in Architectural Education

Hare Kılıçaslan <sup>1\*</sup>, Serbüent Vural <sup>1</sup>

<sup>1</sup> Karadeniz Technical University, TURKEY

Received 20 December 2017 • Revised 27 February 2018 • Accepted 27 February 2018

## ABSTRACT

This study aims to determine the effects of creative drama as a teaching method on undergraduates' academic achievement and on the permanence of knowledge acquired in both theoretical and applied courses in architectural education. The study, which employed a pre-test/post-test control group design, was conducted as part of the bachelor's degree courses Environmental Behavioral Knowledge and Basic Design in the architecture department of Karadeniz Technical University. The study involved 26 undergraduates in the Environmental Behavioral Knowledge course and 48 in Basic Design. From the results of this study, we concluded that undergraduates in the experimental group instructed using the creative drama method showed higher levels of achievement than those in the control group instructed using conventional teaching methods. These results suggest that the creative drama method should be used in architectural education and that further study is needed in this area.

**Keywords:** architectural education, conventional teaching, creative drama, academic success, permanence of knowledge

## INTRODUCTION

Architectural education incorporates several disciplines, from science to art to technology. However, to accommodate unstable social and economic circumstances, architectural education requires changes in program content, learning-teaching strategy and methods. The purpose of creating different and original products and trying for a better one results in constant novelty-seeking in architectural education. An analysis of the recent systems of architectural education shows the emergence of alternative approaches to expression and presentation (Anthony, 2002; Fasli & Hassanpour, 2016; Rodríguez Bernal, 2016).

Architecture students require a holistic perspective and the ability to identify cause-effect relationships, and cultivating these qualities in students throughout architectural education will enable them to use these skills instinctively when seeking new information (Aydnlı, 2003). This has been corroborated by Anderson (2011), who stated that learning by practising enables students to generate better solutions to the problems they will encounter by seeing their visual and physical consequences. Architectural education aims to transmit ways of creative thinking and cultivate individuals who would be able to perceive and generate creative ideas.

According to Piaget, the most important purpose of education is to cultivate individuals able to do and generate new things without repeating what has been done before (Fisher, 2005). Most education programs aim to enhance students' thinking ability as well as their physical and mental health and enable them to experience their own generative power (McCaslin, 1990). Teacher-centred methods, which are frequently preferred in educational environments and based on one-way communication, include activities in which teachers directly convey knowledge to students, and students listen and take notes. However, modern education aims to develop individuals by acknowledging their own cognitive, affective and psychomotor behaviours. DeVries and Zan (2005) noted that teaching how to learn has been gaining importance while the popularity of simply transmitting knowledge to students and other traditional methods have been declining in importance. The quests for active learning related to the teacher-student relationship base on the experiential learning or hands-on learning approach set forth by the educational theorist Dewey (1933). Dewey argues that students should play an active role in the

#### Contribution of this paper to the literature

- The creative drama method based on the principle of “learning by doing” seems to correspond to design process and stages in terms of the containing concepts and be employable in architectural education.
- It can be said that creative drama is an efficient method which has an impact on architecture students’ ability to see, comprehend, evaluate and express themselves.
- To adopt creative drama as an alternative method in the theoretical and applied courses in architectural education will give a significant point of view to this scientific field.

learning process by criticizing the students playing a role of the passive audience (Anthony, 2012). Hence, the need for student-centered architectural education is evident for fulfilling the academic and social needs.

On the document entitled “UIA and Architectural Education: Thoughts, Recommendations”, prepared by the Union of International Associations (UIA), the purpose of architectural education is defined as the development of characteristic methods of architecture and design, by combining the methods of various disciplines and arts that would contribute to the creativity. In this context, it is specified that research and testing of innovations in architectural education should be encouraged in order to fulfill the requirements of fluctuating social and technological conditions (UIA Mimarlık Eğitimi Komisyonu, 2002). NAAB (National Architectural Accrediting Board) specifies the skills and competencies that architecture students must acquire as follows; critical thinking and representation; building construction; technical skills and knowledge; integrated architectural solutions and finally professional practice (The National Architectural Accrediting Board, 2014).

Most of the current architectural education practices are carried out by traditional methods, ignoring contemporary developments, and thus, default information is transferred to the students. However, according to today’s modern developments, the learning process should allow the student and the teacher to work together to generate new information (Ciravoğlu, 2003). Similarly, Chickering and Gamson (1987) argue that the students should use in their daily life whatever they learn by linking them with previous experiences since the education process, in which the students would only listen to the teacher by sitting in the classroom and learn by memorizing the information would be insufficient.

In addition, the acquisition of conceptual ways of thinking can sometimes be realized more easily by using the body language. In this context, we may give the example of the Schweder’s studies, advocating that the architecture is influenced by the energy of the human body, by examining the performance-based applications on concepts body, perception, and gender. In addition, we may give example the studies of School of Architecture and Design in Valparaiso in the 1970s, suggesting that the architectural thoughts are based on the poems (Schweder, n.d.; Galán, 2015; Colomina, Choi, Galán, & Meister, 2012). Hence, it is possible to state that the architectural education process is now transformed into an atmosphere benefiting from the different ways of thinking and interactive methods, and an environment, for which, the process is more important than the outcome. This process evolving from the “teacher” to the “student”, gives the prominence to the individual and his/her ability to design.

The design is a discipline that depends on the culture and conditions, in which the individuals are live. The design, which can be defined as a creative problem solving, forms the basis of all human activities (Cross, 1995; Papanek, 1997; Schön, 2003). Rapoport (2004), as one the pioneers of researchers studying the relationship between people, environment, and behavior, emphasizes the importance of keeping in mind that basic decisions are almost always given in advance, by advocating that the design is for the users. Rittel (1985) defines the designing action as a “decision-making process” oriented for the purpose, while defines the design as a “plan” to fulfill the desired conditions. Hence, it is possible to respond to a problem with many different solutions. As in all problem-solving activities, the design process includes some inductions, containing following stages; decision making, expressing ideas, validating recommendations and evaluation (Cross, 1995; Do & Gross, 1996). Schön (1985) mentions that the designing action may be learned by doing it, hence, both the learning process and the design should enable the student to learn to design. De Bono (1992) points out the prominence of group work in creative education and suggests that both group and individual studies should be addressed.

This study argues that the creative drama method offers a different perspective on architectural education and can be effectively used in both theoretical and applied courses in architectural education. We believe that creative drama, as a student-centred approach, impacts individuals’ awareness of their knowledge, skills and experiences and enable them to apply these skills in their courses by making students more active in their courses and in solving problems by using new knowledge. Additionally, this method offers students a learning environment distinct from a conventional classroom and course format. Creative drama methods also allow for a supportive learning environment that cultivates individuals’ characteristics and experiences. Design matters involve all group members rather than just individuals, enabling all students to actively participate in courses through self-study and group studies. This helps students become aware of problems, generate solutions to these problems and realise that they can find alternative solutions to problems. Therefore, this method enables students to acquire information, improve

**Table 1.** Research design

Groups	Before experiment	During experiment		After experiment	3 months after
	Applied scales	Experimental operations	Period	Applied scales	Applied scales
Experimental group	Pre-test	Creative drama	14 weeks	Post-test	Permanence test
Control group	Pre-test	Conventional teaching	14 weeks	Post-test	Permanence test

upon it and develop skills in applying new knowledge. We thus assume that creative drama is an effective teaching and learning method that allows students of architecture to enhance skills including sight, perception, evaluation and self-expression. Thus, using creative drama as an alternative teaching method contributes a useful new perspective to architectural education.

This is an experimental study to determine the effects of creative drama as a teaching method on architecture students' academic success and permanence of acquired knowledge. Towards this end, we seek to answer the following questions related to our topic:

- 1) Are there any significant discrepancies between the academic achievements of the experimental group in a theoretical course, Environment-Behavior Knowledge, employing the creative drama method and the control group employing a conventional teaching method?
- 2) Are there any significant discrepancies between the academic achievements of the experimental group in an applied course, Basic Design, employing the creative drama method and the control groups employing conventional teaching methods?
- 3) Did the effects of the creative drama method have a significant impact on the levels of permanence of knowledge acquired by the experimental group students?

## METHOD

### Research Model

The pre-test-post-test control group model was used in this study. The independent variable, whose effect was analysed for the experimental groups, was the creative drama method. For the control groups, the conventional teaching method was used. Dependent variables in the study (academic achievement and permanence of knowledge) were analysed by comparing students' pre-test/post-test scores, midterm exam scores and permanence test scores (Table 1).

Both groups took a pre-test before the experiment and a post-test after the experiment. Three months after the experiment, a permanence test was also given to compare the permanence of knowledge acquired by the students in the two groups.

The experimental groups employed creative drama in their lessons while the control groups did not. None of the students in the control groups had taken a drama course before.

### Study Groups

#### *Study group of environment-behavior knowledge course*

The group consisted of 26 students in total; 22 females and 4 males. It was broken into a control and an experimental group, each of which comprised 13 students. Students were grouped according to their previous scores in architectural projects. After determining the groups of students who got approximate scores, the students who got involved in the study were divided into the experimental and the control groups with unbiased assignment.

#### *The basic design course group*

This group comprised a total of 48 students; 31 females and 17 males. It was further divided into a control and an experimental group, each of which included 24 students. Because the students were undergraduates and thus had no grade point average, the groups were selected randomly from the class list counting 1, 2, 3 and 4 in succession. Participants in the study were randomly divided into experimental and control groups.

## Data Collection Tools

### *The achievement test*

For each of the courses (Environment-Behavior Knowledge and Basic Design), an achievement test was prepared to be used as a pre-test and post-test before and after the courses. The pre-tests aimed to determine the participants' initial levels of knowledge while the post-tests measured any discrepancies between the groups' achievement.

The achievement test drafts comprised 20 multiple-choice items proposed by the researcher. The content validity of the tests was confirmed by expert opinion. For the item analysis, split-half reliability was used. Questions whose discrimination index was low according to item analysis were removed from the tests and made ready for the application.

### *Means of midterm scores*

The means of participants' midterm scores were used to compare achievement levels. In Environment-Behavior Knowledge, students took midterm exam 1, midterm exam 2 and the final exam during the semester. Midterm exam 1 included nine open-end questions while the midterm exam 2 included four and the final exam included seven. The questions on the main topics of the courses were jointly prepared by the course instructors and a domain expert to provide the content validity.

For Basic Design, 17 design exercises were conducted during the midterm period and 17 homework topics were given to the students to be returned by the end of the following course period. The contents of the design exercises and the homework subjects were prepared by the course conductors.

### *Permanence test*

A permanence test was conducted three months after the experiment to compare the knowledge permanence of the experimental and control groups. A pool of twelve questions was generated from the open-ended questions in the midterm examinations for the permanence test. The prepared questions are presented to the course director and a specialist for getting their opinions. The validity of the test was ensured by eliminating the questions, which are not found appropriate. Five open-ended questions selected from the collected questions were prepared for the implementation.

### *Data collection and experimentation period*

In this study, creative drama activities developed by the researcher were carried out by the experimental groups. These activities had three phases; warm-up/preparation, impersonation and evaluation-discussion. Theoretical knowledge on class topics was presented through creative drama activities focused on these contents. Activities included warm-up works, plays, improvisations and evaluations.

## **Activities in the Environment-Behavior Knowledge Course**




This course is a compulsory second-year course in architectural education. Course content is based on a book by Gür (1996). In this course, the instructor is active, and the classic teaching method is effective. The activities were carried out in the spring term of 2011–2012. The course took four hours a week and students in the experimental group used the creative drama method. The students in the control group were taught with conventional teaching methods. The creative drama activities performed in the course is exemplified in [Table 2](#).

## **Activities in the Basic Design course**









Basic Design is a compulsory first-year course in architectural education. This course, which has a significant impact on architectural education, was developed in Bauhaus, Germany, as an introductory course for artists and designers (Lang, 1998). In Basic Design, an applied course, students create designs in response to problems; the course has been taught using conventional teaching methods. Activities for the current study took place in fall semester of 2012–2013. The theoretical part of the course, including the first two hours, was presented to the students in the experiment group through the creative drama method. The students in the control group learned this material through conventional teaching methods. The creative drama activities performed in the course is exemplified in [Table 3](#).



**Table 2.** The course activities for Environment-Behavior Knowledge

<b>Subjects</b>	<b>Gains</b>
1. Behavior system 2. Requirement 3. Perception 4. Cognition	1. Being knowledgeable with behaviour system 2. By experience, perceiving the concepts; requirement, perception and cognition
<b>Warm-up/preparation</b>	
Twosome walking activities in which body gestures are examined	Walking activities concerning requirements and actions of individuals at the age of 5, 20, 40 and 70
	
Finding out twosomes/foursomes performing the same body gestures identified before	Producing compositions for 'Gestalt perception theory' with the help of several geometric figures
	
<b>Students' compositions for 'Gestalt perception theory'</b>	
	
<b>Impersonation</b>	
Group improvisations relating to the subject; requirement	Group improvisations relating to the subjects, behavior system and requirement
	
<b>Evaluation-discussion</b>	
Activities for the concepts 'perception' and 'memory' using several compositions by Ebneith, a popular artist	
	

**Table 3.** The course activities for Basic Design

<b>Subjects</b>	<b>Gains</b>
<ol style="list-style-type: none"> <li>1. Review</li> <li>2. Symmetry</li> <li>3. Harmony</li> <li>4. Contrast</li> </ol>	<ol style="list-style-type: none"> <li>1. Being informed of the concepts review and symmetry</li> <li>2. Comprehending the concepts harmony and contrast and the discrepancy between both</li> <li>3. Being informed of significance of the concepts harmony and contrast on the composition</li> </ol>
<b>Warm-up/preparation</b>	
Twosome activities of harmonic and contrast walking	Play of 'harmonies-contrasts'
	
Generating 'symmetric' formations with individual and group performance	Producing anecdotes for four symmetric formations, pictures of which are examined
	
<b>Impersonation</b>	
Twosome improvisations of full review, harmony and contrast	
	
<b>Evaluation-discussion</b>	
Making arrangements concerning types of review (full review, rotating review, variable review) by using several images	Students' products at the phase of evaluation-discussion
	

### Data Analysis

The T-test was used to determine whether there was a statistically significant difference between the experimental groups in which the creative drama method was used and the control groups in which the traditional teaching method was used, between pre-test, post-test, semester grade average and permanence test achievement scores. The t-test is used to test whether the difference between the average of sample groups is significant. For T-



**Table 4.** Normal distribution test of experimental and control groups

Kolmogorov-Smirnov (a)			
	Statistics	df	p
Pre-test	0.170	26	0.053
Post-test	0.167	26	0.059
First midterm exam	0.089	26	0.200
Second midterm exam	0.133	26	0.200
Final exam	0.168	26	0.057
Permanence test	0.096	26	0.200

**Table 5.** Results for pre-test points

Groups	N	X	S	sd	t	p
Experimental	13	66.23	17.48	24	-.243	0.81
Control	13	67.92	18.02			
Total	26					

**Table 6.** Results for post-test points

Groups	N	X	S	sd	t	p
Experimental	13	80.54	7.39	24	2.81	0.010
Control	13	71.00	9.73			
Total	26					

test can be applicable, it is a prerequisite that the difference scores of the two related sets of measures are normally distributed. If the group size is less than 50, the normality of the scores is examined by the Kolmogorov-Smirnov test. If the calculated value "p" is greater than 0.05, the set is interpreted as having a normal distribution of scores (Büyüköztürk, 2011).

## FINDINGS

### Findings Related to Environment-Behavior Knowledge Course

The normal distribution of data obtained from Environment-Behavior Knowledge course was determined by the Kolmogorov-Smirnov test. 95% of the confidence interval was found in data analysis and the significance level was accepted as 0.05. According to the tests performed, the scores of the sets show a normal distribution (Table 4).

### Achievement Test Results for Environment-Behavior Knowledge

The average pre-test points for participants in the experimental and control groups were calculated as part of our efforts to answer our research questions. The results of the T-test used to determine if there was a significant discrepancy between the averages of the groups are presented in Table 5.

No statistically significant discrepancy between pre-test point averages ( $p=0.81$ ;  $p > 0.05$ ) emerged. This indicates that the experimental and control groups had similar levels of proficiency before the study. This can be important for determining the effects of creative drama activities in Environment-Behavior Knowledge.

An achievement test was given as a post-test to the experimental and control groups after the application. The results of the T-test used to detect any significant discrepancy between the groups' achievements are presented in Table 6.

A clear statistically significant discrepancy emerged, with the experimental group showing higher average post-test scores ( $p=0.010$ ;  $p<0.05$ ). The average achievement score of the experimental group was 80.54 while the control group average was 71.00. These results show that the creative drama method used with the experimental group improved students' levels of performance in the course Environment-Behavior Knowledge.

### Midterm Point Averages in Environment-Behavior Knowledge

A T-test was used to determine if a statistically significant discrepancy existed between first midterm exam averages in the experimental and control groups in Environment-Behavior Knowledge. The results are presented in Table 7.

**Table 7.** First midterm exam point averages

Groups	N	X	S	sd	t	p
Experimental	13	75.46	13.30	24	3.41	0.002
Control	13	57.00	14.28			
Total	26					

**Table 8.** Results concerning the second midterm exam point averages

Groups	N	X	S	sd	t	p
Experimental	13	85.77	11.69	24	2.72	0.012
Control	13	69.61	17.93			
Total	26					

**Table 9.** Results concerning the final exam point averages

Groups	N	X	S	sd	t	p
Experimental	13	72.31	5.72	24	5.50	0.000
Control	13	54.46	10.20			
Total	26					

**Table 10.** Results concerning the permanence test point averages

Groups	N	X	S	sd	t	p
Experimental	13	63.00	14.97	24	4.65	0.000
Control	13	35.77	14.92			
Total	26					

An obvious statistically significant discrepancy emerged, with the experimental group showing notably higher first midterm exam averages ( $p=0.002$ ;  $p<0.05$ ). The achievement average of the experimental group was 75.46 while the control group average was 57.00.

A T-test was used to determine if a statistically significant discrepancy held between the second midterm exam averages of the experimental and control groups in Environment-Behavior Knowledge. Results are presented in [Table 8](#).

A clear statistically significant discrepancy emerged, with the experimental group showing higher second midterm averages ( $p=0.012$ ;  $p<0.05$ ). The achievement average of the experimental group was 85.77 while the control group average was 69.61.

A T-test was used to determine if a statistically significant discrepancy held between the final exam averages of the experimental and control groups in Environment-Behavior Knowledge. Results are presented in [Table 9](#).

An obvious statistically significant discrepancy emerged, with the experiment group showing higher second midterm exam averages ( $p=0.000$ ;  $p < 0.05$ ). The achievement average of the experimental group was 72.31 while that of the control group was 54.46. Thus, the experimental group employing creative drama had higher achievement levels on the final exam than the control group.

### Permanence Test Results for Environment-Behavior Knowledge

The T-test was used to identify in the experimental and the control groups for Environment-Behavior Knowledge. Results are presented in [Table 10](#).

An obvious statistically significant discrepancy emerged in the permanence test point averages ( $p=0.000$ ;  $p<0.05$ ), with the experimental group showing notably higher scores. The achievement average of the experimental group was 63.00 while that of the control group was 35.77. Thus, the experimental group taught with creative drama showed higher scores on the permanence test than the control group taught with conventional teaching.

### Findings Related to Basic Design course

The normal distribution of data obtained from Basic Design course was determined by the Kolmogorov-Smirnov test. 95% of the confidence interval was found in data analysis and the significance level was accepted as 0.05. According to the tests performed, the scores of the sets show a normal distribution ([Table 11](#)).

**Table 11.** Normal distribution test of experimental and control groups

Kolmogorov-Smirnov (a)			
	Statistics	df	p
Pre-test	0.126	48	0.056
Post-test	0.108	48	0.200
Midterm averages	0.096	48	0.200
Permanence test	0.090	48	0.200

**Table 12.** Results concerning the pre-test points

Groups	N	X	S	sd	t	p
Experimental	24	61.46	9.83	46	0.962	0.341
Control	24	58.21	13.31			
Total	48					

**Table 13.** Results concerning the post-test points

Groups	N	X	S	sd	t	p
Experimental	24	65.75	12.35	46	2.041	0.047
Control	24	57.62	15.09			
Total	48					

**Table 14.** Results for the midterm point averages

Groups	N	X	S	sd	t	p
Experimental	24	63.42	12.43	46	2.586	0.013
Control	24	55.67	7.81			
Total	48					

### Achievement Test Results for Basic Design

The pre-test averages of the experimental and the control groups were calculated, and the T-test was used to determine if any significant discrepancy held between the groups. Findings are presented in [Table 12](#).

No statistically significant difference between the pre-test averages emerged ( $p=0.341$ ;  $p>0.05$ ). This indicates that the experimental and control groups had similar proficiency levels before the study.

An achievement test was given as post-test to the students in the experimental and control groups after the experiment. The T-test was used to determine if any significant discrepancy held between the groups' post-test scores. The results are presented in [Table 13](#).

A statistically significant discrepancy was found between the groups, with the experiment group showing higher post-test point averages ( $p = 0.047$ ;  $p < 0.05$ ). The average score of the experimental group was 65.75 while that of the control group was 57.62. Thus, the group taught with creative drama showed higher post-test scores than the control group taught with conventional teaching.

### Midterm Averages in Basic Design

The T-test was used to determine if a statistically significant discrepancy held between the midterm averages of the experimental and the control groups in Basic Design. The results are presented in [Table 14](#).

A statistically significant discrepancy was found, with the experimental group showing higher midterm scores averages ( $p=0.013$ ;  $p<0.05$ ). The average score for the experimental group was 63.42 while that for the control group was 55.67. Thus, the experimental group taught with creative drama showed higher midterm scores than the control group taught with conventional teaching methods.

### Permanence Test Results for Basic Design

The T-test was used to determine if any statistically significant discrepancy held between the permanence test point averages of the experimental and control groups in Basic Design. The results are presented in [Table 15](#).

**Table 15.** Results concerning the permanence test point averages

Groups	N	X	S	sd	t	p
Experimental	24	55.12	13.41	46	6.939	0.000
Control	24	26.54	15.08			
Total	48					

A statistically significant discrepancy was found, with the experimental group showing higher permanence test point averages ( $p = 0.000$ ;  $p < 0.05$ ). The average score for the experimental group was 55.12 while that of the control group was 26.54. This suggests that the creative drama method used with the experimental group positively impacted their academic achievement in the Basic Design course.

Overall, the study found that the experimental groups showed higher achievement levels than the control groups, suggesting that the creative drama method had a positive impact on academic achievement in both Environment-Behavior Knowledge and Basic Design. In addition, the creative drama method had a positive impact on the permanence of knowledge acquired in these courses.

## DISCUSSION

Architectural education puts the responsibility for learning on students and thus requires them to actively participate in learning activities. The creative drama process likewise requires active participation. Students bring their own affective qualities, lifestyles and experiences to creative drama activities. These activities motivated students by facilitating empathy, interest and increased attention in class. The creative drama method thus fostered an educational environment that was attractive, encouraging and interactive. In this learning process, knowledge that wasn't acquired at a purely cognitive level went through mental processes and was evaluated by means of affective concepts. The students thus learned by experience, which enabled them to acquire knowledge more efficiently and permanently. These findings all indicate that the creative drama method can improve the students' academic achievement.

Hence, we have shown the effectiveness of the creative drama method and argue that it should be used to achieve the target goals of architectural education. We predict that it will be more beneficial to integrate the creative drama method into courses related to the design process rather than narrow its scope to only two courses, as exemplified in the study. It should be integrated into courses with consideration for the curriculum and weekly course hours of undergraduate courses. It can be used, for example, in courses such as Architectural Design Project, Building Construction or History of Architecture. Warm-up/preparation exercises can be used to get the students to adopt the subject. Through impersonation exercises, activities related to the space-user relation can be conducted involving relevant characters and roles. Activities related to reflection on historical processes for communal living and architectural structures. Warm-up activities/plays can dramatise visual works and impersonations of historic buildings or their architects can be performed. All of these activities enable students to observe and examine structures and immediate surroundings and understand from experience how form and structure are perceived on a human scale. Such activities can facilitate learning through personal engagement with the space; they thus foster permanent learning that will form the basis for the knowledge to be used in the design phase. Thus, subjects that are taught with the creative drama method will not be limited to textbooks but will integrate students' experiences and daily activities. These group activities will provide an unusual and interactive learning environment by requiring students to learn actively.

Architectural education and creative drama have several common aims and targets. Hence, the creative drama method can contribute to architectural education by enabling students to learn by seeing, doing and experiencing.

However, the use of the creative drama method in architectural education also presents challenges and limitations related to curriculum, classroom size and physical conditions. For future studies, the teaching environment must be made suitable for creative drama process by minimising these challenges and limitations.

Creative drama also seems to be effective in the fields other than architectural education. Thus, future studies can examine if the creative drama method itself, students' attitudes towards their courses or their motivation levels have an impact on their academic achievements. In addition, studies should be conducted within longer-term programs, which will make it possible to determine if the method impacts students' creative thinking or overall academic performance.

## REFERENCES

- Anderson, J. (2011). *Architectural design*. Switzerland: AVA Publishing SA.
- Anthony, K. H. (2002). Designing for diversity: Implications for architectural education in the twenty-first century, *Journal of Architectural Education*, 55, 257-267. <https://doi.org/10.1162/104648802753657969>

- Anthony, K. H. (2012). Studio culture and student life. In J. Ockman (Ed.), *Architecture school three centuries of educating architects in North America* (pp. 396-401). Cambridge: The MIT Press.
- Aydınlı, S. (2003). Mimarlık eğitiminde değişen öncelikler. In *Mimar.ist'ten seçmeler mimarlık eğitimi yazıları (2001-2003)* (pp. 41-45). Istanbul, Turkey: TMMOB Mimarlar Odası Istanbul Büyükkent Şubesi.
- Büyüköztürk, Ş. (2011). *Sosyal bilimler için veri analizi el kitabı: İstatistik, araştırma deseni, SPSS uygulamaları ve yorum*. Ankara: Pegem Akademi Yayıncılık.
- Chickering, A. W., & Gamson, Z. F. (1987). Seven principles for good practice in undergraduate education. *AAHE Bulletin*, 39, 7, 3-7.
- Ciravoğlu, A. (2003). Mimari tasarım eğitiminde formal ve enformel çalışmalar üzerine, *Yapı*, 257, 43-47.
- Colomina, B., Choi, E., Galán, I. G., & Meister, A.-M. (2012). Radical Pedagogies in Architectural Education. Retrieved on February 3, 2018 from <http://www.architectural-review.com/education/radical-pedagogies-in-architectural-education/8636066.article>
- Cross, N. (1995). *Discovering design ability, discovering design: explorations in design studies*. R. Buchanan & V. Margolin (Eds.), Chicago: The University of Chicago Press.
- De Bono, E. (1992). *Serious creativity: Using the power of lateral thinking to create new ideas*. London: Harper Collins.
- DeVries, R., & Zan, B. (2005). A constructivist perspective on the role of the sociomoral atmosphere in promoting children's development. In C. T. Fosnot (Ed.), *Constructivism: theory, perspectives, and practice*, New York: Teachers College Press.
- Dewey, J. (1933). *How we think: A restatement of the relation of reflective thinking to the educative process*. Boston: D. C. Heath and Company.
- Do, E., & Gross, M. D. (1996). Drawing as a means to design reasoning, artificial intelligence in design '96. *Workshop on Visual Representation, Reasoning and Interaction in Design*, pp. 1-10.
- Fasli, M., & Hassanpour, B. (2016). Rotational critique system as a method of culture change in an architecture design studio: urban design studio as case study, *Innovations in Education and Teaching International*. <https://doi.org/10.1080/14703297.2016.1174142>
- Fisher, R. (2005). *Teaching children to learn* (2nd ed.). United Kingdom: Nelson Thornes Ltd.
- Galán, I. G. (2015). Radical Pedagogies: School and Institute of Architecture of Valparaíso (1952-1972). Retrieved on February 3, 2018 from <http://www.archdaily.com/775162/radical-pedagogies-school-and-institute-of-architecture-of-valparaiso-1952-1972>
- Gür, Ş. Ö. (1996). *Mekân örgütlenmesi*. Trabzon, Turkey: Gür Yayıncılık.
- Lang, J. (1998). Öğrenciler için mimarlığa giriş: Temel tasarım dersini yeniden düşünmek. In N. Teymur & T. Aytaç-Dural (Eds.), *Temel tasarım/temel eğitim* (pp. 3-14). Ankara: Orta Doğu Teknik Üniversitesi Mimarlık Fakültesi Yayınları.
- McCaslin, N. (1990). *Creative drama in the classroom*. New York: Longman Group.
- Papanek, V. (1997). *Design for the real world: Human ecology and social change*. London: Thames and Hudson.
- Rapoport, A. (2004). *Kültür mimarlık tasarım*. Istanbul: Yapı Endüstri Merkezi Yayınları.
- Rittel, H. (1985). Tasarım eğitiminin tasarımına ilişkin bazı ilkeler. *Mimarlık*, 85, 8, 20-22.
- Rodríguez Bernal, C. M. (2016). Student-centred strategies to integrate theoretical knowledge into project development within architectural technology lecture-based modules, *Architectural Engineering and Design Management*. <https://doi.org/10.1080/17452007.2016.1230535>
- Schön, D. A. (1985). *The design studio: An exploration of its traditions and potential*. London: RIBA Publications Ltd.
- Schön, D. A. (2003). *The reflective practitioner: How professionals think in action*. Bodmin, Cornwall: MPG Books Ltd.
- Schweder, A. (n.d.). Retrieved on February 3, 2018 from <http://www.alexschweder.com/works/>
- The National Architectural Accrediting Board (2014). Retrieved from [http://ced.berkeley.edu/downloads/academic/accreditation/2014\\_NAAB\\_Conditions.pdf](http://ced.berkeley.edu/downloads/academic/accreditation/2014_NAAB_Conditions.pdf)
- UIA Mimarlık Eğitimi Komisyonu (2002). *UIA ve Mimarlık Eğitimi Düşünceler ve Tavsiyeler* (A. Ülkütekin, Trans.). Retrieved on February 1, 2018 from <http://www.mo.org.tr/UIKDocs/reflectionsTR.pdf>



For print copies of this issue or articles please send an e-mail to:

[print@modestum.co.uk](mailto:print@modestum.co.uk)



# The Rising of Green Society: Low-Carbon Consumption as a Result of Environmental Education in China

Lie'en Weng<sup>1</sup>, Shuigen Hu<sup>2</sup>, Zhujun Tao<sup>2</sup>, Jingrui Xu<sup>2\*</sup>

<sup>1</sup> Department of Public Affairs, China Jiliang University, Hangzhou, CHINA

<sup>2</sup> School of Public Affairs, Zhejiang University, Hangzhou, CHINA

Received 18 October 2017 • Revised 12 January 2018 • Accepted 28 February 2018

## ABSTRACT

This article analyzes the factors that influence low-carbon consumption of college students, with the purpose of guiding environmental education in Chinese universities. To that end, a theoretical framework is proposed on the basis of interviews with several groups in combination with literature analysis using grounded theory and empirical verification methods. The study finds that external environment changes, individual psychological awareness, individual living habit, product technology development and low-carbon consumption intention are positively related to low-carbon consumption patterns. Finally, this paper points out that cultivating environmental education concepts of college students should make full use of different policy tools and adhere to the following principles: the combination of various policies and measures, the participation of multiple stakeholders, the popularization of low-carbon concepts, the demonstration of governments, the effectiveness of mass media, clearly defined laws and regulations and informal system construction.

**Keywords:** low-carbon consumption, environmental education, grounded theory

## INTRODUCTION

Reducing carbon emissions, coping with climate change, and educating the public about desirable environmental behaviors are the focus of international community. Faced with increasingly serious environmental problems around the world, the Stockholm Conference on Human Environment was held in 1972. It was the starting point of global environmental education campaigns. In 1977, United Nations Educational, Scientific and Cultural Organization (UNESCO) and the United Nations (UN) Environment Program initiated a conference on environmental education in Tbilisi, the former Soviet Union. In 1987, the World Commission on Environment and Development released the report of *Our Common Future*. In 1992, the Earth Summit put forward the Agenda 21. Recently, environmental education has become necessary general knowledge for citizens, as well as common international responsibilities. In 2007, the UN Climate Change Conference held in Bali, Indonesia is a milestone that formulated the "Bali Roadmap" concerning how to combat climate change and played a positive role in moving the world towards a low-carbon economy. In 2008, there was a discussion about accelerating the low-carbon society development at the Forum of Ministers of Environment in Monaco. In the same year, United Nations Environment Programme (UNEP) set the theme of World Environment Day as "changing traditional concepts and promoting a low-carbon economy."

Since 2013, Beijing Environmental Monitoring Center has repeatedly reported the smog index of "Out of range". As the smog and haze weather aggravate, residents are gradually realizing that carbon emissions have adverse effects on human health. As an international topic, the Energy White Paper came up with the concept of low-carbon economy in 2003. In particular, it calls for actions to control greenhouse gas emissions, promote a low-carbon transition in economic development and develop energy conservation technologies at a Copenhagen conference in the next few years. Furthermore, the 18th National Congress of the Communist Party of China described the ecological protection issue as a single section for the first time. It proposed a basket of long-term strategies for low-

#### **Contribution of this paper to the literature**

- Explaining low-carbon consumption behavior through grounded theory, exploring specific causes of low-carbon consumption behaviors of college students, clarifying factors between subject and object, establishing a theoretical framework, and then using questionnaire as the basis for quantitative analysis to verify the previous theoretical framework.
- Analyzing the stability and validity of factor loading, factor covariance and path coefficient in terms of theoretical framework model and empirical framework. It contributes to cross-cultural research on related topics. The study comprehensively applies multiple questionnaire designs, and innovatively combines with institutional analysis and the framework of model analysis.
- Through identifying factors of low-carbon consumption, the study builds a low-carbon consumption model and put forward feasible suggestions and policies for public sectors to guide low-carbon intentions and environmental education of college students.

carbon economic development, developing emerging industries and new technologies. In addition, it is necessary to improve fiscal and taxation policy support for low-carbon development, formulate low-carbon development laws and regulations, establish low-carbon consumption concepts, encourage green-travelling modes, and launch the “Five Provinces and Eight Cities” project for low-carbon development pilots. China’s 13<sup>th</sup> Five-Year Plan also stressed the unprecedented opportunities and challenges of environmental protection. We must strengthen environmental regulation and assessment, formulate carbon emission standards for key industries, achieve environmental quality improvement and reduce emissions of pollutants, which in turn has led to a transition in the mode of economic development to low-carbon economy. The chairman of Xi Jinping believes that “Environmental development results in prosperity of civilization”. Therefore, the economic and social development evaluation system should reflect the ecological protection and construction indicators. The country should promote green development, low-carbon development and recycling development to form a good economic development model and establish a resource-saving and environment-friendly society. Constructing low-carbon countries and developing low-carbon cities are the requirements of sustainable development and represent the human well-being and responsibilities. There are more than 200 cities adopting low-carbon policies as the goal of economic development in China, such as Shanghai where the World Expo2010 reflecting the concept of low-carbon development from site selection to the operation. Hangzhou also introduced 50 “Low-carbon Deals” to promote the six in one Construction. Under the globally background of actively exploring low-carbon development mode and improving environmental quality, policy supports from home and abroad, contributions from consumers of low-carbon consumption to create sustainable and healthy environmental education, are all the requirements for developing a low-carbon economy. In response to global warming, energy conservation and emission reduction have become important parts of the global social, economic and environmental sustainability discourse. The construction of low-carbon consumption mode is an important means to promote environmental education.

Beijing is an important economic and political city in China, but one of the cities suffering from pollution seriously. The media has paid significant attention to this subject. Studying low-carbon consumption behaviors of Beijing will contribute to providing references for low-carbon development mode in other cities, thereby promote the overall performance of low-carbon society. In addition, as a special group of consumers, college students have incredible demand for consumption. Their consumption behaviors have radioactive and demonstrative effects on the community, family and society. This study has great benefits in guiding low-carbon consumption behaviors of college students. Simultaneously, we could revisit the many problems associated with environmental education concerning the economic, social and political structure, social justice, natural processes, natural systems, and other factors, while cultivating future citizens who have the awareness of environmental civilization. It also provides an effective and complete educational model for school education, and promotes the innovation of modern educational tools.

## LITERATURE REVIEW

### **The Subjective Value of Environmental Education via Behavioral Intentions in Low-Carbon Consumption**

Environmental education aims to promote multiple and complex educational goals – knowledge, meaningful understanding of self and environment, pro-environmental attitudes and values, and readiness for environmental action (Granit-Dgani, Kaplan, & Flum, 2017). The importance of knowledge of behavior and level of skill notwithstanding, people’s actual behavior is undergirded, most proximally, by their behavioral intentions. Nevertheless, extensive research suggests that behavioral intentions are fundamental for the behavior to be enacted and constitute ‘the best single predictor of behavior’ (Granit-Dgani et al., 2017). Thus, rather than a primary focus

on the goals of behavioral change, current environmental education programs should aspire to achieve goals that combine environmental knowledge and readiness for environmentally-oriented behaviors with self-reflection and identity exploration about environmental issues, thus promoting students' identities around environmental values, goals, self-perceptions and their associated actions (Stevenson, Dillon, Wals, & Brody, 2013).

As the advanced stage of ecological awareness, low-carbon intention emphasizes on maintaining environment bases for social development. It pays attention to overall optimization of social economic development and ecological environment to comprehend and pursue human development. It stresses that examining the relationship between human and nature from the perspective of low-carbon value, the relationship between human and human as well as the development of human beings themselves is the reflection of human's conception from low-carbon dominant rules and low-carbon restrictive conditions. The connection of low-carbon intention and environmental education are homologous, inherited and innovative. 1) Low-carbon intention and environmental education have somethings in common. Environmental problems are caused by the rapid growth of population, modern science-technology and productivity. Concerns about the deterioration of living environment have led to the emergence of environmental education. The original motivation comes from caring and cherishing of human lives. To some extent, the low-carbon intention is an innovative achievement of environmental education. Both are concentrated on the relationships between human beings and the environment, and aimed to solve environmental problems and achieve sustainable development. Their tasks are to improve human environmental awareness and effective participation, to popularize the knowledge and skills of environmental protection, and to cultivate environmental protection talents. They are social practice activities through specific means. 2) The low-carbon intention provides an innovative environment for environmental education. Nowadays, developing low-carbon economy has become a great issue at all levels of government, enterprises and the public. The inputs from policies, technologies and resources have increased unprecedentedly. Aimed to protect the ecological environment and improve environmental quality, environmental education requires policy supports from governments, technical supports from enterprises. It also requires general public to put into practice through daily behaviors. The appeal of low-carbon economy intention in communities provides an innovative environment for environmental education at a deeper level. 3) Environmental education provides a platform for low-carbon intention. Through imparting environmental knowledge, demonstration of environmental protection skills and training of environmental protection attitudes, from the three levels of knowledge, awareness and behavior, people are guided to protect the environment and preserve environment in line with the philosophy of "3L" (low energy consumption, low emission and low pollution). Environmental education provides a psychologically platform for low-carbon intention.

### **The Factors of Low-Carbon Consumption Behavior and Low-Carbon Intention**

The previous fragmented research identifies some factors of low-carbon consumption. The findings are that personal statistic variables (Abrahamse, Steg, Vlek, & Rothengatter, 2005; Henion, 1972; Muetzelfeldt, Robertson, Bundy, & Uschold, 1989), psychological awareness (Chen, 2007; Fraj & Martinez, 2007; Poortinga, Steg, Vlek, & Wiersma, 2003) and other factors may be positively related to on low-carbon consumption.

Among demographic variables, most studies focus on the notion that younger, more educated and wider environmental knowledge groups prefer low-carbon consumption. But there is still no agreement. Henion (1972) argues that there is a positive correlation between education and consumption behavior, and that the higher the education level and the higher the sensitivity to environment, the more consumers tend to buy low-carbon and other green products. Muetzelfeldt et al. (1989), however, points out that there is no correlation between educational attainment and the impact of consuming intention. Bohlen, Schlegelmilch, and Diamantopoulos (1993) argues that environmental knowledge (general knowledge and specific knowledge) has a significant correlation with low-carbon consumption. Conversely, an empirical analysis by Pickett et al, shows that environmental knowledge has no effect on the consumption behavior of consumers. Abrahamse et al. (2005) identifies demographic variables such as the age, education, and profession of the population, which impact on energy using behavior and willingness, and that impacts of different demographic indicators are different. According to Steg (2008), the accumulation of personal knowledge influences on low-carbon consumption.

Concerning factors of personal life attitude and psychological awareness, individual living habits and psychological awareness have impacts on low-carbon consumption intention and affect low-carbon consumption behavior in further. Through the survey of social status quo, Poortinga et al. (2003) finds that the lifestyle and attitude of residents are not significantly related to consumption behavior. Chen (2007) considers that personal motivation influences attitudes and therefore can be regarded as the function of policy value, environmental perception, personal willingness and other factors. Fraj and Martinez (2007) divides the cognitive, affective and intentional components into three dimensions of environmental attitudes and uses the Structural Equation Modeling (SEM) model to demonstrate that environmental attitudes are directly related to actual environmental behavior. Steg (2008) also identifies the impacts of consumer motivation on consumption intention, and divides

energy behavior into two aspects: psychological strategy and structural strategy. Psychological strategy (access to information, etc.) affects individual willingness and motivation. The effective change of structural strategy (laws and regulations, etc.) will affect personal consumption behavior to a large extent. Abrahamse (2005) concludes that reward approaches will stimulate individual consumption behavior, which has a short duration. Additionally, Michaelidou and Hassan (2010) uses models to prove that consumer behaviors impacted by price, environmental perception and living habit, which lead consumers to choose between organic and stocked products differently.

From the perspective of external influence and product technology, most studies find that the maturity of product evolution and the attitudes of surrounding consumer behaviors will have different degrees of impact on their own low-carbon consumption behavior. In other words, if setting series of promotional measures or improving product quality, it will be likely to stimulate low-carbon consumption behavior. As reported by Winett et al. (1985), the publicity of mass media has a significant effect on shaping the consumption behavior of consumers, and the high strength of publicity will facilitate public consumption and thus increase consumer benefits. Bohlen et al. (1993) also proves that there is a significant correlation between behavior and environmental attitudes in the dimensions of purchasing behavior and recycling behavior. Lane and Potter (2007) emphasizes the factor of the technology of product evolution. If the performance and technical conditions of the product tend to mature, consumers would tend to make positive comments on the product, thus forming purchasing behaviors. Steg (2008) considers that the model power in energy behavioral strategies, the infrastructure in structural strategies, and the level of service delivery potentially impact on consuming behavior. Wang and He (2011) applies the grounded theory to build a model of Consciousness-Situation-Behavior from the perspective of qualitative analysis, then concludes that the attitude of individual behavior and social factors together lead to low-carbon consumption behavior of residents.

To sum up, (1) from the perspective of research methods, most literatures mainly focus on the test of single hypothesis design and series of models for testing empirical hypothesis, which lacks theoretical summary; (2) from the research results concerning factors of low-carbon consumption of college students, there is no consensus, and even some studies have direct conflicts; and (3) most research proves the direct influence of independent explanatory variables on low-carbon consumption, ignoring the indirect effect of pre-variables.

## RESEARCH QUESTION

By studying key factors of low-carbon consumption behavior, this study explores low-carbon environmental education, strengthens the role of low-carbon environmental education, and promotes social responsibility for environmental protection. Exploring factors of low-carbon consumption of college students is the main task of this study, which uses a combination of research methods, such as the field survey and questionnaire survey. The extensive and effective surveys cover humanities colleges, scientific engineering universities, key universities and ordinary colleges, thereby choosing Beihang University, Renmin University of China, Capital Medical University, Beijing City University as examples. First of all, carrying out qualitative research on the factors of low-carbon consumption, the study sets open questions for investigation and multi-level codes to establish a theoretical framework based on the grounded theory. Then, we quantify previous qualitative research on the low-carbon consumption of college students through survey with large samples from four universities. After removing irrelevant elements and explaining relevant elements, this study proposes feasible advices for low-carbon education. The purpose of this research is to explain the following questions:

**Research Question 1:** What factors influence the formation of environmental sustainability education in the process of low-carbon consumption behavior?

**Research Question 2:** In the process of influencing low-carbon consumption behaviors, what is the nexus of these factors?

## MATERIALS AND METHODS

### The Research of Grounded Theory

As an inductive research paradigm, the grounded theory is mostly used in qualitative analysis. It emphasizes a natural process from proposing problems to theory constructions, which advocates a number of raw materials processing and induction system without any assumption, thus, to obtain the "social reality" theory. By multiple coding structure, this theory often requires objective and comprehensive accesses to information, so that the collected information will have characteristics of authenticity, representative and extensive. It breaks through the "procedural" style of empirical paradigms and prevents the influence of experiences and notions on actual investigations (Glaser, 2017). Grounded theory emphasizes conceptualization and theorizing original realistic materials and preventing preconceived thinking, aiming to form an objective and accurate understanding of social

issues by social process analysis. It attaches the utmost importance to the procedures of organizing materials and recording notes after an interview. The classic grounded theory includes substantial coding and theoretical coding, which correspond to two levels of data processing and theoretical structure. The program grounded theory includes open coding, spindle coding, and selective coding designed to understand the true thoughts of their hearts by communicating with the interviewee (Glaser, 2017).

This article applies the method of programmatic grounded theory coding. Firstly, the open coding is based on the central issue of "affecting the low-carbon consumption of college students." By designing less than 10 open questions for respondents, after the interview, researchers obtain no less than 600 original sentences according to the arrangement of notes and recordings, and then refine research concepts. Due to the existence of a certain degree of cross-meaning between the meanings of sentences, they need to be categorized. The concepts of similarities, existing relationships, and causal relationships should be merged into one category. The inconsistency and less frequent conceptions should be excluded. The original initial concept would be transferred into fewer categories (generally less than 50). The second is the spindle encoding. Due to a large number of categories, the relationship between categories is not clear. Under the full understanding of the research objects and research contexts, researchers should explore primary categories in the initial categories based on the logical order and the relationships between the primary categories. The third is selective coding. Selective coding is to further select the core category in the spindle coding, analyze the relationships between the core categories and the main categories and sub-categories, finally describe and analyze the phenomenon.

After previous three rounds of coding processes, the core category is assumed as "factors for low-carbon consumption of college students". If the main category has covered essential elements of the core category and there are no other constituent factors between the main categories, then researchers are not necessary to collect more information. Therefore, the study could construct a theoretical model consisting of several dimensions for explanation and elaboration.

### Empirical Verification-SEM Model Analysis

In contrast to qualitative research, quantitative research quantifies multiple dimensions of the theoretical framework according to the grounded theory. With questionnaire survey, this study adopts a combination of empirical investigations, literature research, comprehensive induction and other methods to conduct the empirical quantitative research. The questionnaire method is on the basis of literature reading, mainly introducing the scientific sampling questionnaire method, exploring factors of low-carbon consumption of four universities in Beijing as case studies. The questionnaire includes information on the basic status (gender, grade, educational level, place of birth and monthly consumption) of the respondents and psychological awareness of the college students, living habits, external influence factors and product performance, etc.

Firstly, SPSS is adopted for statistical analysis. We use descriptive statistics to do basic frequency analysis on the demographic variables of respondents in five aspects, including gender, grade, educational background, birthplace and monthly consumption status. Accordingly, we can make basic descriptions and grasp of the factors that affect the low-carbon consumption of college students.

Secondly, factor analysis method is introduced to summarize and integrate independent variables to simplify the data. The original sequence variables are converted into fixed variables by factor scores, and logistic regression analysis and multiple regression analysis are conducted. Factor-Payload variables are transcoded into dummy variables, along with the factor scores obtained previously as independent variables, select "If there is a product of the same function, will you give priority to buy low-carbon products?" as a dependent variable for logistic regression analysis. Then we choose low-carbon consumption behavior which is convenient for regression analysis to establish the multiple regression model. Following these steps, we can compare and analyze the results.

Finally, the AMOS software is applied for SEM model analysis. Through P value observation of the structural path, we conduct the verification of relationship between the P value and path coefficient, and track the overall effect and indirect effects of standardized estimates of the two-tailed test results to examine factors of low-carbon consumption by the dependent variables under the influence of mediating variables.

### Research Hypotheses

On the basis of related elements detected by the grounded theory, the hypotheses are built upon quantitative analysis. From the scope of low-carbon products, this article explores the main factors of purchasing behavior regarding psychological awareness of consumers, as well as the effect path of low-carbon products consumption behavior affecting by external influence, the degree of product development, individual living habit and other factors.

### ***Psychological awareness and low-carbon consumption***

With the energy conservation and low-carbon economy, individual psychological awareness will form the demand preference and individual evaluation when choosing low-carbon products. According to previous studies, individual psychological awareness can be further decomposed into multiple levels of individual awareness of environmental responsibility, individual environmental concerns, individual perception of behavioral effect and the low-carbon knowledge. This is can be proved and illustrated by Michaelidou and Hassan (2010), who discuss the factors of psychological awareness. Based on previous researches, we put forward the following hypothesis:

**H<sub>1</sub>:** The positive low-carbon psychological awareness has positive impacts on the consumption of low-carbon products.

### ***Individual living habit and low-carbon consumption***

Individual living habit is defined as the daily performance beyond the consuming purchase, which can be measured as turning off lights, using low-power appliances, etc. Individual living habit potentially affects the consumption behavior of college students. This view has been described and explained by Poortinga, Steg, Vlek, and Wiersma (2003), Wang and He (2011). When individuals living habits tend to environmental care and energy conservation, they are more likely to generate green consumption and low-carbon consumption. Therefore, the following hypothesis is formed:

**H<sub>2</sub>:** A Good individual living habit has positive impacts on low-carbon consumption.

### ***External influence and low-carbon consumption***

External factors, such as surrounding people, media, policies, governmental demonstration and social ethos, positively affect college students in society. College students can use the Internet and mobile phones to comprehend the systemic protection and preferential policies of low-carbon products. Additionally, promotional patterns of advertisements will also influence the consumer psychology of college students, resulting in low-carbon products consumption behavior. Steg (2008) and Winett et al. (1985) hold different attitudes towards this issue. For purpose of exploring external influence factors, the following hypothesis is formed:

**H<sub>3</sub>:** Positive word-of-mouth publicities have positive impacts on low-carbon consumption.

### ***The degree of product evolution and low-carbon consumption***

The technical conditions as the evolution of low-carbon products, related facilities, product diversity etc., have affected the consumption of college students to a certain extent. College students would produce the purchase behavior of products or not, through the low-carbon products and other products in the economic benefits, recycling convenience comparisons. When the functions and benefits of low-carbon products exceed ordinary products, concerns and purchases of low-carbon products will be generated. These relevant factors can be found in Winett et al. (1985) and Wang and He (2011). Therefore, this article proposes the following hypothesis:

**H<sub>4</sub>:** The better the low-carbon product evolution, the more positive effect it has on low-carbon consumption of college students.

## **Population and Sample Selection**

The respondents of the questionnaire encompass a wide range of college students with different ages, educational backgrounds, and occupations. The survey adopts on-site and online forms to ensure reliable and scientific samples. The locations of the survey include Beihang University, Renmin University of China, Capital Medical University and Beijing City University. Renmin University and Beihang University are national key universities.

## **Data Collection**

In the qualitative research, based on literature research, we collect first-hand information through opening questions and panel discussions. The first is purpose sampling. Selecting seven students of Beihang University as separate interview samples, begin theoretical sampling

The next step is to take Renmin University of China, Capital Medical University, and Beijing City University as examples to meet the basic requirements from the sample of the grounded theory. In the process of quantitative research, a complete random sampling method is introduced to collect a large number of samples for data analysis and verification of relevant elements of the interview. A total of 500 questionnaires are sent to collect 420 valid questionnaires, the recycling rate of 84.0%. The data collection is shown in the [Table 1](#). In addition, the



**Table 1.** Sample Features

Features	Classification	Number	Percentage (%)	Features	Classification	Number	Percentage (%)
Grade	1	108	25.71	Major	Humanities	188	44.76
	2	178	42.38		Science and Engineering	218	51.9
	3/4	109	25.96	Origins	Arts	14	3.33
	Postgraduates	25	5.95		City	315	75
Gender	Male	198	48.33	Countryside		105	25
	Female	206	51.67				

questionnaire recycling excludes the questionnaires with obvious wrong answers and high similarity of answers to ensure the accuracy and validity of the data. From the qualitative research and in-depth understanding of small samples, to quantitative studies and data interpretation of large samples, this study achieves scientific and rigid problem research.

## RESULTS

### Grounded Theory of the Framework of Construction

Deviations may easily occur in the encoding process due to personal preferences and result bias. Hence, this encoding involves three people. Results are compared during the encoding process. If similarity is above 75%, then the process will continue. If similarity is below 75%, then recoding will be conducted to ensure the scientificity and comprehensiveness of samples.

**Table 2.** Open coding

Category	Initial concepts
Consumption concepts	<ul style="list-style-type: none"> <li>• Firstly, personal consciousness and concept of responsibility are not clear. They contend that low carbon is mainly the concern of the government.</li> <li>• They haven't formed the belief or habit in not choosing low-carbon products.</li> <li>• Correct concept of consumption plays an important role in guiding people's behaviors.</li> </ul>
Government initiative	<ul style="list-style-type: none"> <li>• The government itself failed in low-carbon consumption. As university students, if they follow the good example set by the government, it will be of great assistance.</li> <li>• The government plays quite a significant role. If government takes the initiative, other people will pay more attention to this matter at least.</li> <li>• If government officials take part in the practice themselves, university students will be very touched.</li> </ul>
Understanding on severity of environmental issues	<ul style="list-style-type: none"> <li>• Carbon dioxide has become a serious issue. So university students should focus on low-carbon consumption.</li> <li>• If the current amount of CO<sub>2</sub> is controlled, green GDP growth is quite difficult to be achieved.</li> </ul>
Knowledge of low-carbon consumption	<ul style="list-style-type: none"> <li>• University students can understand the benefits of low-carbon consumption, so it is necessary to publicize some knowledge of low-carbon consumption.</li> <li>• Due to the lack of knowledge on what low carbon is, people don't have the standards of selection.</li> <li>• In fact, everyone is aware of low-carbon lifestyle, but the knowledge on low-carbon consumption is not quite popular yet.</li> </ul>
Social atmosphere	<ul style="list-style-type: none"> <li>• Although university students know the necessity of doing this, they don't have the favorable atmosphere of guidance.</li> <li>• The social context of low-carbon consumption and energy conservation should be developed.</li> </ul>
Influence of people around	<ul style="list-style-type: none"> <li>• Current publicity about low carbon merely stays on paper. If schools implement some practice, it will play an important role.</li> <li>• Parents don't pay much attention to low-carbon consumption, so I don't care much about it either.</li> </ul>
Media publicity	<ul style="list-style-type: none"> <li>• Now that media are so developed, repeated publicity and propagation can make people aware of serious issues and change their own behaviors.</li> <li>• Mass media don't conduct adequate publicity, so people tend to ignore this problem in purchasing.</li> <li>• There is shortage of publicity and effectiveness.</li> </ul>
University students' sense of responsibility	<ul style="list-style-type: none"> <li>• University students don't have the awareness to protect the society and assume social obligations.</li> <li>• For them, changing the thinking pattern is rather important. It should pose unconsciously impacts and influence on students' faith.</li> <li>• University students' values haven't completely developed. It is necessary to start with their sense of responsibility.</li> </ul>
Personal effects	<ul style="list-style-type: none"> <li>• Even a drop of water is still use. University students, as individuals of the nation, should become aware their own roles in the society.</li> <li>• Due to shortage of current resources, individuals play significant and important roles in cherishing every little bit of resources.</li> <li>• The general public doesn't realize the severity and operability of low-carbon consumption.</li> </ul>

**Table 2 (continued).** Open coding

Category	Initial concepts
Infrastructure	<ul style="list-style-type: none"> <li>• Parents tend to drive cars more often, as they don't think the public transportation is comprehensively developed yet.</li> <li>• Now, it is necessary to build up some basic infrastructure and facilities to make people think that low-carbon products are well-developed.</li> <li>• There seems no useful ways to recycle things like used batteries.</li> </ul>
Product Evolution	<ul style="list-style-type: none"> <li>• Although companies are also doing this thing, it is still not enough to develop low carbon products.</li> <li>• Currently, low carbon products haven't developed that many categories, it is not convenient to buy them.</li> <li>• Development and popularization of low-carbon products are quite important to the consumption of university students.</li> </ul>
Living habit	<ul style="list-style-type: none"> <li>• Go out with a stack of paper. The Japanese have a sense of conservation when talking about these details.</li> <li>• Living habit play an important role in personal behavior.</li> </ul>
Economic development	<ul style="list-style-type: none"> <li>• Now that economic development and conditions have become much better, people are also more boastful.</li> <li>• Rich students seldom care about the low carbon products.</li> </ul>
Comfort level	<ul style="list-style-type: none"> <li>• Low-carbon lifestyle involves a lot of trouble. We also need to know what low carbon is. Life won't be easy that way.</li> <li>• As for computers, we don't shut them down often quite, we can still use them on the next day.</li> <li>• It is not quite convenient to recycle and reuse.</li> </ul>
Pressure from people around	<ul style="list-style-type: none"> <li>• Other people may despise me if I pick up a waste bottle in the campus.</li> <li>• Most people tend to give gifts with nice packaging. If gifts are poorly packaged, it won't be good for the friendship.</li> </ul>
Constraint conditions	<ul style="list-style-type: none"> <li>• There is no specific punishment for not using low carbon products, so there is no restriction.</li> <li>• A limit should be set for extra charges or usage restriction of high-carbon products.</li> </ul>
Laws and regulations	<ul style="list-style-type: none"> <li>• The current laws and regulations are not comprehensive and targeted for low-carbon consumption.</li> <li>• The government lacks adequate executive ability. It is also related to people's lack of focus on low-carbon consumption.</li> <li>• If the government can enact some policies and laws about low-carbon consumption, they will at least establish authority and effects of deterrent forces.</li> </ul>
Exaggerated effects	<ul style="list-style-type: none"> <li>• When I bought something at the duty-free airport in Taiwan, I saw black lungs on the packages of cigarette. It is quite good for the current environmental protection.</li> <li>• Proper intimidation is a good thing. At least it is beneficial to everyone.</li> </ul>
Emotional resonance	<ul style="list-style-type: none"> <li>• Current patterns of publicity only focus on benefits of products rather than true implementation of national policies.</li> <li>• Propagation of environmental protection doesn't cause resonance. It needs to focus more on aspects and things in close relations with people's daily life.</li> </ul>
Association publicity	<ul style="list-style-type: none"> <li>• Association plays an important in universities today. Associations like Green Wing can conduct some activities on a regular basis.</li> </ul>
Students' organization	<ul style="list-style-type: none"> <li>• Nowadays, associations rarely pay attention to low-carbon consumption. I live in Shahe. To a large extent, students' environmental organization in the school seldom implement activities in this regard. They only conduct activities about singing and dancing.</li> <li>• Students' association union once conducted an activity about low-carbon consumption, and it produced positive effects.</li> </ul>
Form innovation	<ul style="list-style-type: none"> <li>• Now, people aren't willing to take part mainly because the activities are not quite interesting.</li> <li>• If activities are conducted in interesting ways, many people are expected to participate.</li> </ul>
Face factors	<ul style="list-style-type: none"> <li>• Many people tend to buy things with nice packages as they want to keep up appearances.</li> <li>• Ostentation and extravagance do exist in universities and colleges.</li> </ul>

**Table 3.** Axial Coding

Main category	Corresponding Scope	Gist of scope
External influence	Influence of other people	Families and friends' points of views on low carbon
	Social influence	Social assessments and pressure on low-carbon consumption behaviors
	Policy influence	Influence of policy changes on low-carbon consumption of university students
	Media influence	Propagation forms, intensity and resonance, effects of spreading terrors by the media
Product Evolution	Product innovation capability	Corporate competence in developing low-carbon products
	Development of basic infrastructure	Defective recycling system. Impacts of backward designs
	Product and hardware development	Bad product quality and less categories impact people's concept of low-carbon consumption
Consumption intention	Consumption possibility	University students' viewpoints on low-carbon product consumption
	Intention in participating in low-carbon consumption activities	University students' consumption intention on low-carbon activities and sense of participation in products
Living habit	Taking public transport	University students' viewpoints on green transportation impact consumption
	Usage of low-carbon products	University students' habits of using low-carbon products impact low-carbon consumption
	The awareness of reusing products	Costs of product recycling impact costs of low-carbon consumption
Psychological awareness	Understanding of environment subjects	Necessity and feasibility of low carbon implementation
	Individual consciousness of responsibility	University students' sense of responsibility of low-carbon consumption and environment
	Knowledge system	Personal knowledge on what low carbon involves
	Individual effects	University students' cognition on giving play to personal effects

**Table 4.** Relationship structure of open coding

Relationship structure	Structural gist
External influence—Consumption intention—Consumption behavior	External influence can pose influence on consumption intention, and low-carbon consumption behaviors of university students.
Product Evolution—Consumption intention—Consumption behavior	Development of product infrastructure and capability of recycling are external factors to low-carbon consumption behaviors. But interactions of different factors may pose impact consumption behaviors on consumption intention.
Consumption intention—Consumption behavior	Consumption possibility is the intervening variable. It can direct impact consumption behaviors
Living habit—Consumption intention—Consumption behavior	Living habit is the internal condition to cause consumption behavior. It poses impacts on consumption intention through the level of consumption behaviors
Psychological awareness—Consumption intention—Consumption behavior	Individual sense of liability and knowledge on low carbon pose direct influence on low-carbon consumption intention. They also become important conditions to influence consumption behavior.

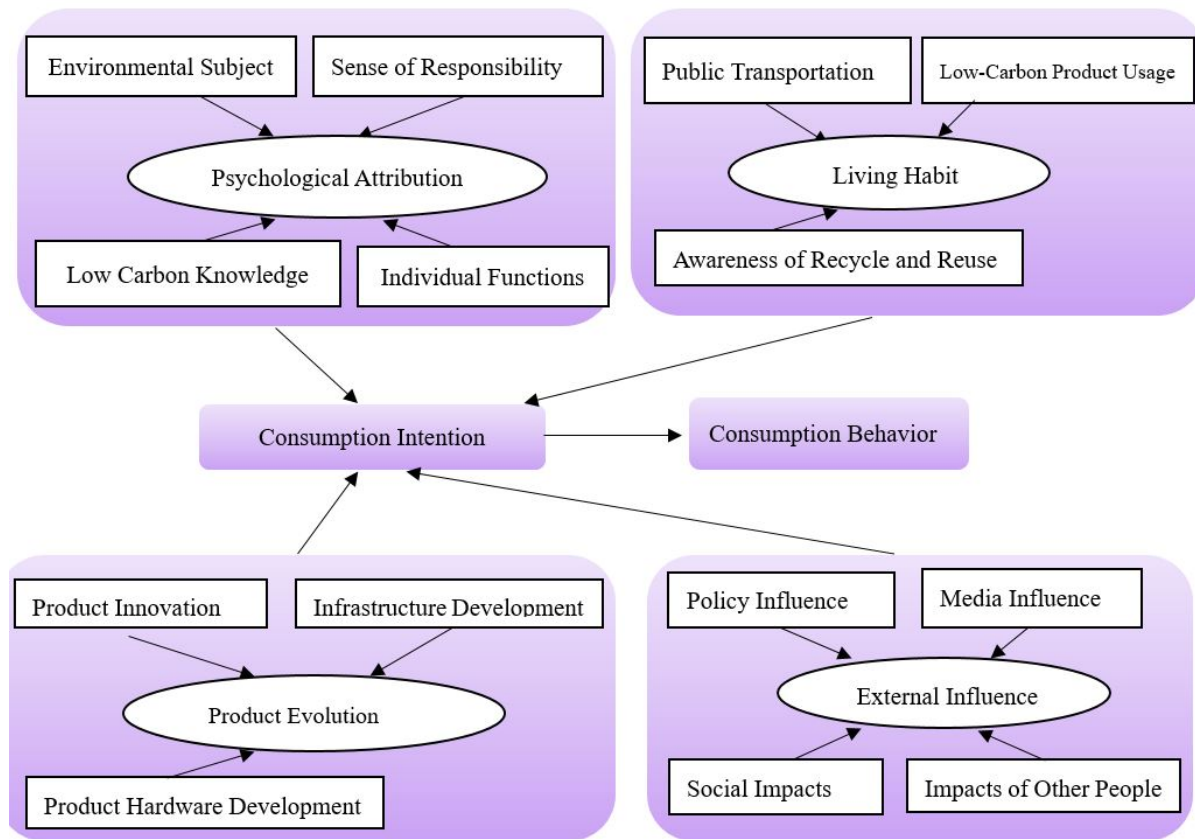


Figure 1. Theoretical Framework of Low-carbon Consumption

### Empirical Validation Based on Questionnaire

Questionnaires consist of surveys and scoring scales of basic situation. Basic situation surveys include demographic variables, observation and utilization of daily consumption. Scales are developed on basis of scholars' research and studies, including psychological awareness, external influence, product evolution, living habit, usage intention and usage behaviors. Likert scale and 5 points scoring method are adopted mark scores of 1 to 5 based on "Don't quite agree", "Don't agree", "Agree", "Relatively agree", and "Quite agree". 500 copies of questionnaires are released. 420 copies of valid questionnaires are collected. The rate of collection is 84%.

Psychological awareness indexes setting consulted research and studies by Michaelidou and Hassan (2010), including sense of responsibility ( $x_1$ ), knowledge on low carbon ( $x_2$ ), focus on the environment ( $x_3$ ), behavioral effects ( $x_4$ ). External influence indexes setting consulted research and studies by Steg (2008) and Winett et al. (1985), including government example ( $x_5$ ), policies ( $x_6$ ), media ( $x_7$ ), social atmosphere ( $x_8$ ) and influence of other people ( $x_9$ ). Product evolution designs consulted research and studies by Winett et al. (1985) and Wang and He (2011), including infrastructure ( $x_{10}$ ), recycle outlets ( $x_{11}$ ), product categories ( $x_{12}$ ) and product quality ( $x_{13}$ ). Besides, according to relevant life situation, the paper also discusses whether other indexes, such as product appearance and price tolerance, is related to consumption behaviors of university students. Living habit index setting consulted research and studies by Poortinga et al. (2003), Wang and He (2011), including traffic ( $x_{14}$ ), usage of low carbon products ( $x_{15}$ ), usage habits ( $x_{16}$ ) and product reuse ( $x_{17}$ ). Consumption behavior is set as the explanatory variable, which mainly consulted question designs by Lane and Potter (2007), Poortinga et al. (2003). The intervening variable of purchase intention consulted index designs by Lao and Wu (2013). Tests are conducted based on the following indexes: low-carbon product propagation intention ( $m_1$ ), low carbon purchasing intention ( $m_2$ ), intention of participating in low-carbon activities ( $m_3$ ), intention of low-carbon transport ( $m_4$ ).

The scale reliability is tested by Gronbach coefficient. Most scholars tend to accept that scientific scale reliability  $\alpha$  is greater than 0.7. According to reliability analysis results, the reliability value of total scale is 0.921. Coefficient of other dimension is also greater than 0.7. Construct validity uses confirmatory factor analysis to set up PA-LV models. After using the AMOS21.0 software analysis, results are shown in Table 5. Null hypothesis includes many independent variables. The paper extracts the common factor through maximum variance method, and conducts

**Table 5.** Variable Measurement

Latent variable	Main theme	Problem description	Cronb-ach's $\alpha$	No.
Consumption behavior	Time tolerance	Spend extra time to purchase low-carbon products	0.799	Y
	Price tolerance	Pay higher prices for some low-carbon products.		
	Product purchasing	Willing to purchase low-carbon products in nearby supermarkets and stores.		
	Product purchasing	Seldom purchase products with excessive packaging		
	Product purchasing	Seldom purchase disposable products		
Consumption intention	publicity intention	Become volunteers for low carbon consumption	0.851	m <sub>1</sub>
	purchase intention	Purchase low carbon products within financial and time limits		m <sub>2</sub>
	Participation intention	Take the bus to work to realize low-carbon society.		m <sub>3</sub>
	Activity intention	Participate in low-carbon and energy-conserving abilities.		m <sub>4</sub>
Psychological awareness	Sense of responsibility	Feel obligated to practice low-carbon consumption and save energy.	0.750	X <sub>1</sub>
	Knowledge on low-carbon	Know what products can be recycled.		X <sub>2</sub>
	Behavior effects.	Understand that low-carbon consumption behavior is consumption pattern with low energy consumption, low pollution and discharge.		X <sub>3</sub>
	Focus on environment	Carbon dioxide emissions exceed standard levels in the city.		X <sub>4</sub>
External influence	Government examples	If government officials take part in low-carbon consumption, other people will also engage in the practice.	0.739	X <sub>5</sub>
	Policy influence	In the case of policy subsidies, you will purchase low-carbon products.		X <sub>6</sub>
	Influence of other people	Families may impact your low-carbon consumption.		X <sub>7</sub>
	Social context	The social context of low carbon conservation is not developed yet		X <sub>8</sub>
Product Evolution	Infrastructure	Modern infrastructure is not comprehensive, so people throw garbage around. Newspaper and TV publicity influence low carbon consumption.	0.701	X <sub>9</sub>
	Recycling outlets	Can't find the outlets for recycling low carbon products		X <sub>10</sub>
	Product categories	Less categories of low carbon products can't meet demands of purchasing.		X <sub>11</sub>
	Product quality	Bad product quality also impacts purchasing intention		X <sub>12</sub>
living habit	Transport	You will choose public transport to go out, such as subway and buses	0.828	X <sub>14</sub>
	Article usage	You use household appliances with low electricity consumption.		X <sub>15</sub>
	Usage habits	You turn off lights, electric appliance and water taps when leaving.		X <sub>16</sub>
	Recycle and reuse	You may dispose things rather them throw them away after they break down.		X <sub>17</sub>

factor analysis with SPSS20.0 software. On condition that KMO value is 0.920 and Bartlett sphericity test results conform to standards, the paper conducts factor analysis on measurement indexes of the scale, and retains the items with factor loads greater than 0.5.

Considering the correlation between consumption intention and low-carbon consumption behavior, this paper firstly analyzes the correlation between variables and consumption intention as well as consumption behavior, laying the foundation for regression analysis and structural equation modeling. Results indicate that variables like psychological awareness, external influence, living habit, product evolution have significant correlation with consumption intention and consumption behavior, and sig. = 0.000. Therefore, it can be found a strong association between independent variables measured in four dimensions and dependence variables and intervening variables.

**Table 6.** Correlation Analysis

	Psychological awareness	External influence	Living habit	Product Evolution	consumption intention
Consumption intention	0.545***	0.609***	0.599***	0.457***	1***
Consumption behavior	0.474***	0.507***	0.498***	0.417***	0.679***

Note 1 : \* signify  $p < 0.05$ , \*\* signify  $p < 0.01$ , \*\*\* signify  $p < 0.001$

**Table 7.** Multiple Regression Analysis

Variable sequence	R	R <sup>2</sup>	$\Delta R^2$	F Value	B	Sig
1. Consumption intention	0.679	0.460	0.458	356.604***	0.630	0.000
2. Psychological awareness	0.690	0.476	0.473	189.235***	0.132	0.002
3. Product Evolution	0.697	0.486	0.483	131.370***	0.153	0.003

**Table 8.** Main Effect and Interaction Analysis of Psychological Awareness, External Influence and Living Habit

Variable	df	MS	Sig.
Psychological awareness	17	18.848	0.000
External influence	12	3.182	0.000
Living habit	12	18.329	0.000
Psychological awareness * External influence	71	12.250	0.000
Psychological awareness * Living habit	61	8.035	0.107
External influence * Living habit	48	6.433	0.416
Psychological awareness * External influence * Living habit	36	11.923	0.000

In order to understand different influences exerted by low-carbon consumption factors, this paper adopts multiple stepwise regression method to explore the impact of predictors, such as consumption intention and psychological awareness on dependent variables. As the multivariate regression model should be constructed when there are no multiple collinearity and autocorrelation among variables, correlation tests and statistical tables are adopted to examine the overall conditions. Results show that the overall residual of model satisfies normal assumption and the model can be build. In order to examine whether this model has autocorrelation, this paper conducts Durbin-Watson testing with DW coefficient 1.905, and it can be concluded that random error term has no autocorrelation. Furthermore, through the measurement of tolerance and Variance Inflation Factor (VIF), the influence of multiple collinearity is also excluded as results indicate that VIF value ( $< 2$ ) and tolerance ( $> 0.6$ ) all meet the requirements of modeling. Therefore, those selected indicators are reasonable and multivariate regression model can be constructed. In addition, this paper uses Wald stepwise regression method to prevent multiple lineal model problem caused by all highly correlated variables entering a general lineal model. Then, apart from population statistics, putting living habit, consumption intention, psychological awareness, product evolution, external influence into the equation, it can be concluded that the multiple correlation coefficient between three predictors and the dependence variable is 0.697, the determination coefficient 0.486 and F test significant. The regression coefficient of consumption intentions is the highest, reaching 0.630.

According to the predicated explanatory power, production evolution has the best forecasting performance towards consumption behavior and the explanatory power is 48.6%. According to regression coefficient, consumption intention has a positive  $\beta$ , thus it can be seen that the explanations consumption intention, psychological awareness and product evolution towards consumption behavior are all positive and the constant is 2.56. Therefore, we can build a model as  $Y = 2.560 + 0.630X_1 + 0.132X_2 + 0.153X_3$ .

When it comes to the contributory factors of low-carbon consumption, considering that interaction may occur among psychological awareness, external influence and living habit, thus we conduct multivariate analysis of variance by taking these three variables as fixed factors and consumption behavior as a dependent variable to examine this assumption. According to the result, psychological awareness, external influence and living habit have significant main effects and there is an interaction among psychological awareness and external influence ( $p < 0.01$ ), psychological awareness as well as external influence and living habit ( $p < 0.05$ ). Therefore, undergraduates' perception for external environment and living habit is still influenced by living habit (Table 8).

We build a low-carbon consumption behavior SEM by taking items in low-carbon consumption quantity table as observed variables and low-carbon consumption behavior, consumption, external environmental influence, psychological awareness, production evolution, living habit as latent variables. The normality test of every single indicator is the absolute value of the value of kurtosis and skewness, all meeting criteria. Therefore, it is reasonable for this paper to analyze consumption behavior by using maximum likelihood method. SEM is constructed as:

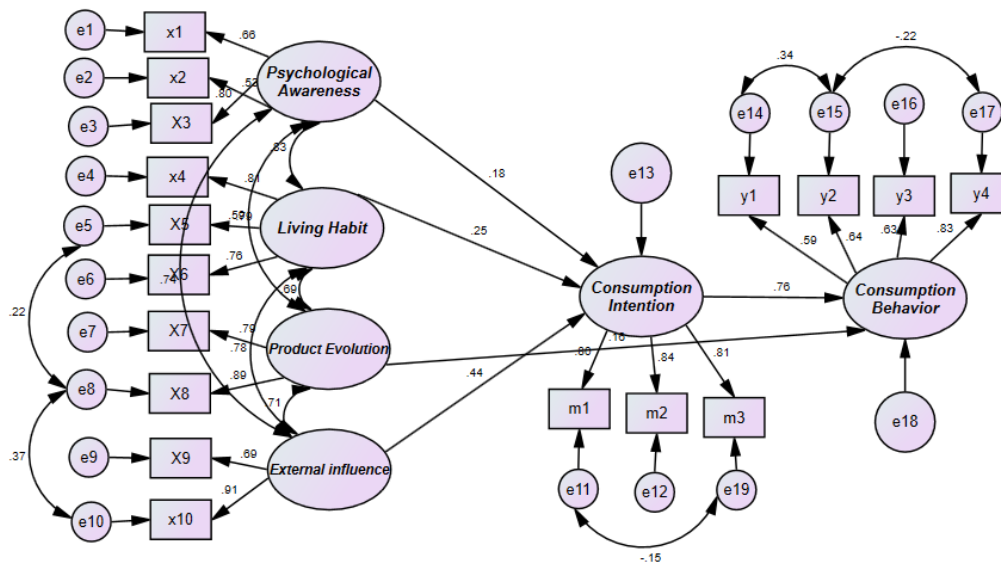


**Table 9.** Consumption Behavior SEM Equation PNFI

Index	CMIN/DF	GFI	CFI	IFI	PGFI	PNFI	RMSEA
First model	5.785	0.823	0.756	0.896	0.632	0.617	0.107
Revised model	2.437	0.933	0.950	0.951	0.613	0.628	0.059

**Table 10.** Research Hypothesis Testing

Research Hypothesis	Standardized Path Coefficient	P-value	Conclusion
Psychological awareness->Consumption intention	0.10	0.04	Support
Product evolution ->Consumption behavior	0.16	0.04	Support
External influence->Consumption intention	0.63	< 0.001	Support
Living habit-> consumption intention	0.12	0.03	Support
Psychological awareness-> External influence	0.72	< 0.001	Support
Psychological awareness->Living habit	0.79	< 0.001	Support
Psychological awareness-> Product Evolution	0.50	< 0.001	Support
Living habit-> External influence	0.76	< 0.001	Support
Product Evolution -> External influence	0.61	< 0.001	Support
Living habit-> Product Evolution	0.60	< 0.001	Support



**Figure 2.** Low-carbon Consumption Behavior SEM Model

$$\eta = \beta\eta + \Gamma\xi + \zeta \tag{1}$$

$$x = \lambda x\xi + \delta \tag{2}$$

$$y = \lambda y\eta + \varepsilon \tag{3}$$

where x represents the observed explanatory variable; y the observed explained variable;  $\lambda x$  and  $\lambda y$  contrasted coefficient matrix;  $\xi$  the structural independent variable;  $\eta$  the structural dependent variable;  $\delta$  and  $\varepsilon$  are corresponding error terms.

According to the statistics in the **Table 9**, most indicators in the first model are not ideal and far from fit criteria. Then we revise this model in accordance with correlation and it can be seen that product evolution can exert direct influence on consumption behavior without the help of consumption intention, thus both variables are directly related. What’s more, considering that there may be a correlation among independent variables, we associate them with each other and confirm the validity of this assumption.

SEM is revised in accordance with the M.I value, CR value and LR value, and correlates residual errors in related terms with each other. After revised, the model fits well and coefficients of its paths are significant: e5 is correlated with e8, e8 with e10, e11 with e19, e14 with e14 and e15 with e19. The path graph can be seen in **Figure 2**, and fit index of SEM is shown in **Table 9**.

According to the path graph, for use intention, external influence has the largest standardized coefficient, reaching 0.44, and the second is living habit, stands at 0.35 while psychological awareness has the smallest standardized coefficient, which is only 0.18. It can be concluded that the influence degree of contributory factors on low-carbon consumption behavior is external influence > living habit > psychological awareness.

## DISCUSSIONS AND CONCLUSIONS

First, the changing external environment and sustainable environmental education are primary drivers for undergraduates to perform low-carbon consumption. The university is a kind of small society, and the attitude and behavior of individuals are prone to be influenced by each other. What's more, the freedom to dispose of time makes it possible for the public to have access to the mass media, an important way to disseminate information. By perceiving behaviors of reference group, people may change their own behaviors unconsciously, thus the external environment is of great significance for people to adapt to low-carbon consumption. According to the Attribution Theory proposed by Heider, reasons of individual behavior can be classified into two parts: Internal Attribution (Individual Attributes) and External Attribution (Environmental Attributes). The former includes individual personality, motivation, emotion, attitude and effort while the latter includes surrounding environment and luck (Heider, 2013). In in-depth interviews, some interviewees tend to attribute their inappropriate behaviors (such as not adopt low-carbon consumption pattern) to contextual factors (external attribution). The study in this paper indicates that the influence of external factors, such as surrounding people and the government's leadership, are the most important stimulator of low-carbon consumption. It is noted that most televisions and online media that people are exposed to be advocating luxurious lifestyle and consumption patterns. Under such circumstances, the public tend to pursue conformity. Therefore, relevant government authorities should restrict properly the spread of information concerning materialism and make efforts to promote civilized, frugal, environmental friendly and low-carbon consumption pattern. In the process of environmental education, the government should correctly publicize the idea about environmental protection and the government officials should take the leading role and guide the public to maintain a positive attitude towards low-carbon consumption, so as to foster a sustainable development idea that is consistent with the development of our times.

Second, internal factors, which include psychological awareness and living habit, provide reference for undergraduates' environmental education concept. An individual's living habit and psychological awareness, including environmental possibility awareness and personal knowledge, will exert varying influence on low-carbon consumption. As the independent individual, the public have their awareness of tendentiousness and their choices of behaviors are made through their psychological awareness. When this awareness comes more from personal experiences and practices, the foresting performance (includes short-term performance and long-term performance) of low-carbon psychological awareness towards low-carbon consumption pattern will be enhanced dramatically. In contrast, when this awareness comes more from boring textbooks, this kind of foresting performance will decrease and the effects of environmental education concept will be compromised, thus having an adverse effect on guiding undergraduates to a healthy and environmentally friendly lifestyle. However, many people are now still lacking understanding of environmental crises, such as climate change. Some people, though realizing these issues, take a negative attitude and even choose to "ignore" it. We call this kind of phenomenon as "ostrich mentality". It is only when low-carbon psychological awareness reaches a "tipping point" that it can help establish the low-carbon consumption pattern. When awareness is consistent with behavior, the low-carbon consumption education concept will be built naturally. Therefore, policymakers should work to enable the public to realize their individual responsibility for mitigating climate change, so as to encourage preferable transitions in consumption patterns and raise consciousness of environmental sustainability.

Finally, the development of low-carbon products and technologies, including innovative capability, degree of product recall, variety and quantity of products, provides guarantee for undergraduates to establish sustainable environmental education concept. Policymakers should make changes in situational and structural factors, such as infrastructure, product and technology conditions as well as policies and regulations. According to our in-depth interviews and empirical studies in this paper, infrastructure (public transportation, recall network and charging station etc.), product and technology conditions (accessibility of low-carbon products and maturity of technologies), policies and regulations (government policies and their enforcement) and other situational and structural factors have differing influences on the cost and benefit of low-carbon consumption pattern. In the process of environment education, we should improve infrastructure and multi-dimensionally reduce the individual cost of practicing low-carbon consumption, so as to encourage the public to establish the environmentally friendly ideology. Consumers often rank products in accordance with their criteria, thus those products which are simple and convenient can meet the public's needs. Reduced opportunity cost means that, driven by satisficing, the public can exchange for the maximum income with the minimum cost, leading to low-carbon consumption behavior. Therefore, the development of low-carbon products plays an important role in support of low-carbon products.

## ACKNOWLEDGEMENTS

The authors gratefully acknowledge funding support from the Projects of National Social Science Foundation of China (granted No. 16FZZ001), National Key Technology Research and Development Program of the Ministry of Science and Technology of China (granted No. 2015BAK26B03), Major Project of National Social Science Foundation (granted No. 12 & ZD020) and Big Data+ Smart Medical and Health-care Services Innovation Team of Zhejiang University. We also wish to acknowledge assistance and suggestions from several colleagues, particularly Kai Fang, who provide many valuable discussions and comments during the research.

## REFERENCES

- Abrahamse, W., Steg, L., Vlek, C., & Rothengatter, T. (2005). A review of intervention studies aimed at household energy conservation. *Journal of environmental psychology*, 25(3), 273-291. <https://doi.org/10.1016/j.jenvp.2005.08.002>
- Bohlen, G., Schlegelmilch, B. B., & Diamantopoulos, A. (1993). Measuring ecological concern: a multi-construct perspective. *Journal of Marketing Management*, 9(4), 415-430.
- Chen, M. F. (2007). Consumer attitudes and purchase intentions in relation to organic foods in Taiwan: Moderating effects of food-related personality traits. *Food Quality and preference*, 18(7), 1008-1021. <https://doi.org/10.1016/j.foodqual.2007.04.004>
- Fraj, E., & Martinez, E. (2007). Ecological consumer behaviour: an empirical analysis. *International journal of consumer studies*, 31(1), 26-33. <https://doi.org/10.1111/j.1470-6431.2006.00565.x>
- Glaser, B. (2017). *Discovery of grounded theory: Strategies for qualitative research*. New York: Routledge.
- Granit-Dgani, D., Kaplan, A., & Flum, H. (2017). Theory-based assessment in environmental education: a tool for formative evaluation. *Environmental Education Research*, 23(2), 269-299. <https://doi.org/10.1080/13504622.2016.1144172>
- Heider, F. (2013). *The psychology of interpersonal relations*. New Jersey: Psychology Press.
- Henion, K. E. (1972). The effect of ecologically relevant information on detergent sales. *Journal of Marketing Research*, 10-14. <https://doi.org/10.2307/3149598>
- Lane, B., & Potter, S. (2007). The adoption of cleaner vehicles in the UK: exploring the consumer attitude-action gap. *Journal of cleaner production*, 15(11), 1085-1092. <https://doi.org/10.1016/j.jclepro.2006.05.026>
- Lao, K. F., & Wu, J. (2013). Research on Influencing Mechanism of Consumer Green Consumption Behavior Referring to TPB. *Finance and Economics*, 2013(2), 91-99. <https://doi.org/10.3969/j.issn.1000-8306.2013.02.011>
- Michaelidou, N., & Hassan, L. M. (2010). Modeling the factors affecting rural consumers' purchase of organic and free-range produce: A case study of consumers' from the Island of Arran in Scotland, UK. *Food Policy*, 35(2), 130-139. <https://doi.org/10.1016/j.foodpol.2009.10.001>
- Poortinga, W., Steg, L., Vlek, C., & Wiersma, G. (2003). Household preferences for energy-saving measures: A conjoint analysis. *Journal of Economic Psychology*, 24(1), 49-64. Retrieved from [http://www.unternehmenssteuertag.de/fileadmin/user\\_upload/Redaktion/Seco@home/nachhaltiger\\_Energiekonsum/Literatur/Zahlungsbereitschaftsfragen/Poortinga.pdf](http://www.unternehmenssteuertag.de/fileadmin/user_upload/Redaktion/Seco@home/nachhaltiger_Energiekonsum/Literatur/Zahlungsbereitschaftsfragen/Poortinga.pdf)
- Muetzelfeldt, R., Robertson, D., Bundy, A., & Uschold, M. (1989). The use of Prolog for improving the rigour and accessibility of ecological modelling. *Ecological Modelling*, 46(1-2), 9-34. [https://doi.org/10.1016/0304-3800\(89\)90067-7](https://doi.org/10.1016/0304-3800(89)90067-7)
- Steg, L. (2008). Promoting household energy conservation. *Energy policy*, 36(12), 4449-4453. <https://doi.org/10.1016/j.enpol.2008.09.027>
- Stevenson, R. B., Dillon, J. W., Arjen, E. J., & Brody, M. (2013). The evolving characteristics of environmental education research. In: R. B. Stevenson, M. Brody, J. Dillon, & A. E. J. Wals (Eds.) *International Handbook of Research on Environmental Education*. Routledge, New York, NY, USA, pp. 512-517.
- Wang, J. M., & He, A. Z. (2011). Psychological Attribution and Policy Paths of Consumer's Low Carbon Consumption Behavior: An Exploratory Research Based on Grounded Theory. *Nankai Business Review*, 2011(4), 80-89. <https://doi.org/10.3969/j.issn.1008-3448.2011.04.010>
- Winett, R. A., Leckliter, I. N., Chinn, D. E., Stahl, B., & Love, S. Q. (1985). Effects of television modeling on residential energy conservation. *Journal of applied behavior analysis*, 18(1), 33-44. Retrieved from <https://www.ncbi.nlm.nih.gov/pmc/articles/PMC1307985/pdf/jaba00027-0035.pdf>

<http://www.ejmste.com>



<http://www.ejmste.com>



<https://twitter.com/ejmste>



<https://www.facebook.com/ejmste>



<http://modestum.co.uk/>



[publications@modestum.co.uk](mailto:publications@modestum.co.uk)

# Application of Engineering Education in Entrepreneurship Construction System

Yan-Ming Cheng <sup>1</sup>, Kai Wang <sup>1\*</sup>, Il-Kyoo Lee <sup>1,2</sup>

<sup>1</sup> Beihua University, Jilin, CHINA

<sup>2</sup> Kongju National University, KOREA

Received 8 February 2018 • Accepted 20 February 2018

## ABSTRACT

At present, many engineering students have failed to start a business due to the lack of good entrepreneurial ability and quality. The main crux is that colleges and universities only pay attention to the professional knowledge and skills for the cultivation of engineering students, but ignore the entrepreneurship education. With the popularization of higher education and employment situation of graduates in our country becoming more and more serious, college student's entrepreneurship has become a new trend of employment of college graduates. It is imperative to cultivate the entrepreneurial ability of college students. At present, scholars in our country have done a lot of research on entrepreneurship education, but seldom integrate the research of entrepreneurship education into the engineering talents training program. Therefore, this paper analyzes the existing problems of engineering education in colleges and universities in our country through literature research and questionnaire survey, and based on previous studies, puts forward a new type of engineering students training program that combines entrepreneurial education and specific strategies for training entrepreneurship ability of engineering talents. Looking forward to provide reference for engineering education in our country.

**Keywords:** engineering education, entrepreneurship construction system, applied talents

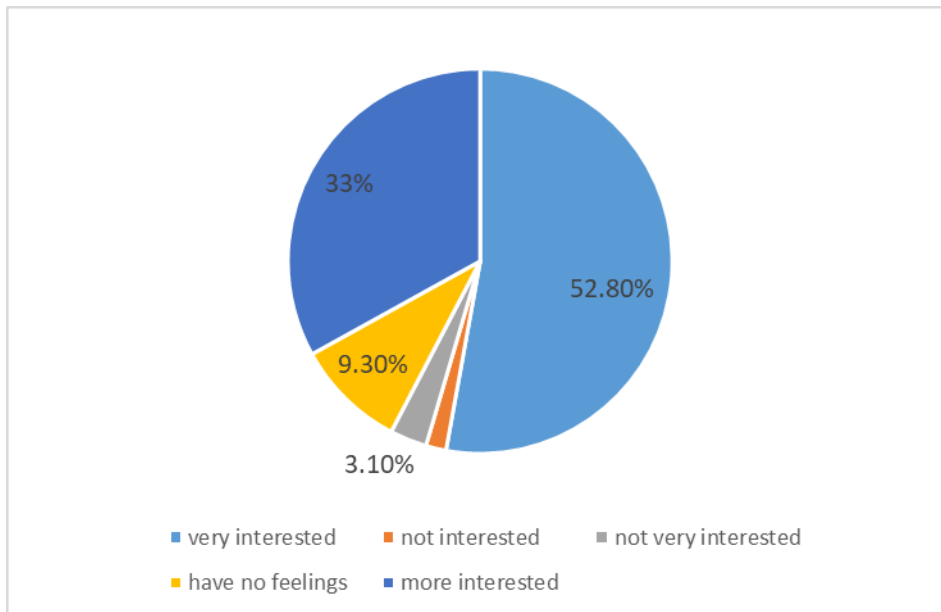
## INTRODUCTION

Engineering education is the activity of teaching knowledge and principles to the professional practice of engineering. It includes the initial education for becoming an engineer, and any advanced education and specializations that follow. Since the central government put forward the "mass entrepreneurship and innovation" in 2013, the central and local governments have published a series of specific measures to promote entrepreneurship. These policies provide college students with a good entrepreneurial opportunity. The rate of entrepreneurship for Chinese university graduates rose from 2.3% in 2013 to 3% in 2017. Statistics show that most of the students who choose to start their own businesses are graduates of economics, management and marketing. There are few engineering students who choose to start their business after graduation. Moreover, although the entrepreneurial rate has shown a significant upward trend, but according to statistical data, the entrepreneurial success rate of college students in China is only 2.4%. Therefore, how to build the engineering applied talents entrepreneurship education system has become an urgent problem to be solved.

The connotation structure of entrepreneurial quality is divided into physical quality, entrepreneurial awareness, adventurous spirit, willpower, and ability to capture business opportunities. I counted out the survey results of College Students' entrepreneurial awareness as shown in **Figure 1** by the way of distributing the questionnaire through the Internet. The research shows that about 85% of college students have entrepreneurial intention. But the real proportion of students engaged in entrepreneurial activities during the university is not high. Domestic scholar (Lin & Si, 2014) has shown that the success factors of college students' entrepreneurial include objective factors and subjective factors. Objective factors mainly include resources and entrepreneurial opportunities. Subjective factors

**Contribution of this paper to the literature**

- The research is of certain theoretical value in reforming engineering education school’s courses for enhancing engineering graduates’ comprehensive accomplishment and employability, and further strengthening school’s competitiveness.
- At present, a majority of engineering graduates have lower entrepreneurial ability and employability in our country, which has been becoming more and more serious, which should be brought to the forefront seriously.
- Based on engineering students training program combining entrepreneurial education and specific strategies for training entrepreneurship ability of engineering talents, the school should perform systematic and sufficient training on students.



**Figure 1.** Statistical chart of entrepreneurial intention of college students

mainly include college students’ entrepreneurial intention and entrepreneurial ability. At present, the researches on the construction of the entrepreneurship training system in China is mainly focused on what the entrepreneurial resources have done to the entrepreneurial achievements, or on what the entrepreneurship has done to the entrepreneurial achievement. They have not put forward a complete system of cultivating the entrepreneurship of engineering applied talents, which is adapt to China’s national conditions. This paper intends to use the questionnaire survey and literature research method to put forward a new model of cultivating the talents of engineering applied, which is suitable for our nation conditions.

## LITERATURES AND REVIEWS

### The Current Situation of Entrepreneurship Education for Foreign Students

#### *Early start and rapid development*

In the United States, the Harvard Business School’s Myles Mace pioneered the entrepreneurial training course “Management of New Enterprises” in 1947 (Ting et al., 2017). New York University and Stanford University opened the MBA entrepreneurship education curriculum system in 1967 (Yongbo et al., 2017). At present, there are already more than 500 American colleges offering entrepreneurial courses. Entrepreneurship education is included in formal education. In the UK, the government has set up a science center to manage and carry out entrepreneurship education. Later, they built a National Committee for college students’ Entrepreneurship to implement entrepreneurship education (Zhang, Duysters, & Clodt, 2014). It is known that the British entrepreneurship course is divided into two categories: “for entrepreneurship” and “about entrepreneurship” (Guerrero, Cunningham, & Urbano, 2014).



### *Hiring experienced teachers to teach*

American college teachers are not all full-time. The school will hire some entrepreneurs who have some research results in academia. These teachers not only educate students, but also their own teachers for entrepreneurial training. Like the United States, British universities employed a number of academic entrepreneurs as part time teachers (Zhu, Zhang, & Ogbodo, 2017). Almost all of these teachers have entrepreneurial experience and have achieved some results. Universities in Germany specifically employ successful or experienced entrepreneurs to train students for entrepreneurship. And in the school, as long as the content associated to innovation and entrepreneurship, it will be taught by the economic and management related teachers. Japanese universities encourage teachers to do part-time jobs in Enterprises. They encourage teachers to practice in front of the production (Feng et al., 2011). At the same time, they also hire entrepreneurs to serve as teachers in colleges and universities (Chang & Chen, 2014).

### *Professional education mode*

Entrepreneurship training model in American colleges and universities is divided into the focus mode, the radiation mode and the magnet mode (Chang & Chen, 2014). The focus mode is mainly used to cultivate students in business institutes and management institutes to be professional entrepreneurial talents (Bo, 2017). The magnet model is aimed at the students of the whole school, which is used to explore the students' entrepreneurial awareness and entrepreneurial spirit. While, the radiation mode combines the focus mode with the magnet mode. Not only providing entrepreneurship education for non-business and management students, but also encourage teachers from different institutes to participate in entrepreneurship education. Students in engineering applied majors can participate in the entrepreneurial education of magnet mode or radiation mode. The entrepreneurial education models in UK include the integration model, the intermediary model and the external support model (Guerrero et al., 2015). The integration mode refers to the infiltration of entrepreneurship education in all aspects of personnel training in colleges and universities. This is a relatively recessive educational model. The intermediary mode drives the students to accept the entrepreneurship education through the form of the project. And the external support education mode needs the employer, community and other stakeholders to take part in the enterprise education, and to implement the entrepreneurship education activities with students. Engineering students can obtain entrepreneurship education through intermediary and external support models.

### **Current Situation of Entrepreneurship Education in Domestic Colleges and Universities**

Compared with the developed countries, entrepreneurship education in China started relatively late. In 1988, Tsinghua University pioneered the eight courses associated with entrepreneurship education for MBA. At the same time, it has opened the course of "high-tech entrepreneurship management" for undergraduate education (Feng et al., 2011). And since 1988, Tsinghua University student entrepreneurship program competition has been held every year. During the competition, the school will organize various lectures and training focused on entrepreneurship knowledge. After more than ten years of development, although China has made some achievements in entrepreneurship education and the rate of entrepreneurship is also rising, but entrepreneurship education has not formed a system yet. It is still in the experimental phase. Most of the courses offered by the schools are elective courses, and the teaching contents are mainly theoretical and empirical. Entrepreneurship education teachers are mostly teachers of the school administration positions. After years of development, the current mode of entrepreneurship education in our country has gradually formed the entrepreneurship education focused on professional knowledge and skills and the entrepreneurship education and comprehensive education focused on knowledge and skills of entrepreneurship (Guerrero et al., 2015). There is a lack of training system for the entrepreneurial skills of engineering applied talents.

### **RESEARCH DESIGN**

In order to solve the problem of constructing educational system for engineering talents, we have adopted the research methods of literature research and questionnaire survey. First of all, we use the literature research method to look up a large number of research achievements on entrepreneurship education of domestic and foreign country. And it is concluded that the following problems exist in the entrepreneurship education of engineering applied talents in China.

### **Entrepreneurship Education Lacks Relevance**

Statistics shows that the teachers of entrepreneurship education in various colleges and universities are administrative personnel. They not only have no entrepreneurial experience, but also do not know the direction of entrepreneurship that adapted to the major. While, entrepreneurial activities have different requirements for

**Table 1.** Basic situation of the questionnaire survey

	<b>Essential information</b>	<b>Proportion (%)</b>
Gender	Male	45.8
	Female	54.2
Grade	Freshman	20
	Sophomore	18.5
	Junior	15.2
	Senior	12.6
	Master	21.2
	Doctor	12.5
Major categories	Arts	47.3
	Science	52.7

entrepreneurs in different industries. Therefore, entrepreneurship education in colleges and universities does not play a role in practice.

### Lacking of Entrepreneurship Practice Teaching

In the process of entrepreneurship education in Colleges and universities, the teaching content is mainly theoretical. Practice teaching is mostly the experiment that assists to proof theory, which is carried out in a simulation space. It has seriously constrained the students' innovative thinking because of the lack of practice in the actual environment. Students can not physically understand the entire operating process of a company that relies on technical support. And they can't communicate with the market and consumers, so that they do not understand the real needs of the market. Under such conditions, students will become rigid and not adapted to the market demands. It is likely to lead to the failure of entrepreneurship.

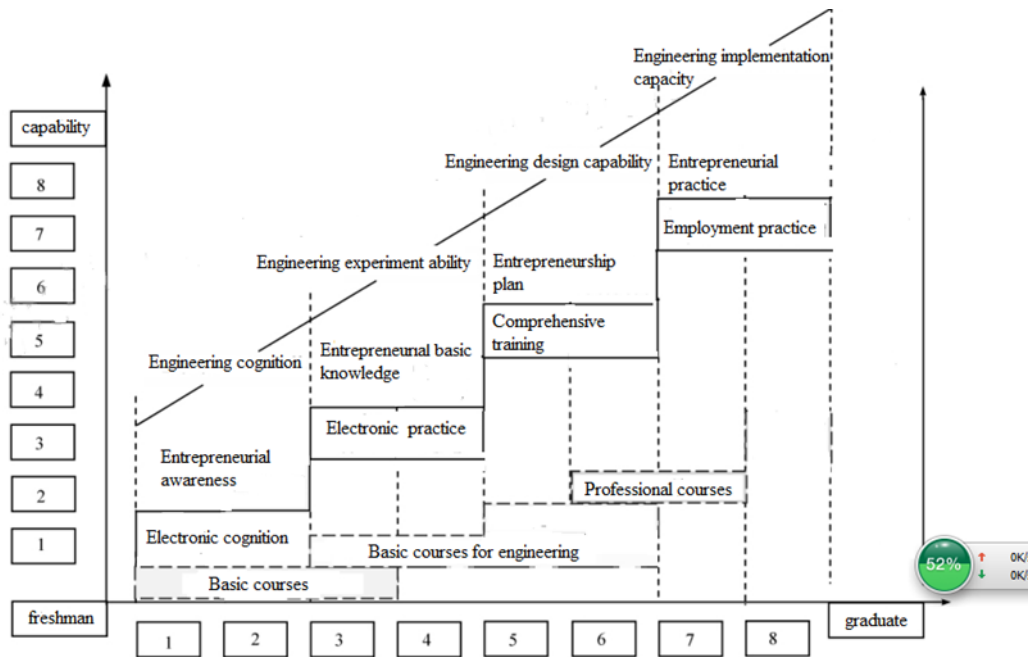
### The Weak Teacher Resources

Compared with the teachers of entrepreneurship education in developed countries, the number of teachers in our country is less. Most of our entrepreneurial training teachers are full-time teachers in our school's administrative personnel. They do not have entrepreneurial experience, and do not know the professional knowledge and skills associated with students. So they are not helpful to the entrepreneurship of students. Therefore, the weak faculty has become the main factor restricting the development of college students' entrepreneurial ability.

Meanwhile, on the basis of reading related literature, the author makes some assumptions about the problem of entrepreneurship education in China. We designed a questionnaire based on the hypothesis. The content of the questionnaire includes entrepreneurial intention, the content of entrepreneurship education in Colleges and universities, the ways for college students to accept entrepreneurship education, and the quality of entrepreneurship education in Colleges and Universities. We interviewed 452 students in the form of a network questionnaire. These students came from 45 universities in 17 provinces (or municipalities directly under the central government). The basic situation of questionnaire survey is shown in [Table 1](#). The survey result shows that most of the schools have set up employment guidance courses for engineering applied students. But there are nearly no schools offering specialized entrepreneurship programs. The training aim for engineering applied talents is focused on the professional knowledge and skills, and the training for entrepreneurial ability is not included. They neglect the entrepreneur education because of laying too much stress on cultivating employees. Although there are elective courses in colleges and universities which are entrepreneurial associated, the teaching content is not scientific and systematic. And there is no clear syllabus and teaching objectives. Without a perfect talent training objective and curriculum system, the entrepreneurship education just stays on the surface and thus there is no practical significance. If students want to learn the knowledge of entrepreneurship, they can only participate in the entrepreneurship competition organized by the students' association or entrepreneurship training classes after school. In a few schools that offer entrepreneurship courses, most of them arrange the course of entrepreneurship education for senior students. And at this stage, students are busy with the livelihood problems after graduation, no time to plan for entrepreneurship. The timing of entrepreneurship education is lagging behind.

## DISCUSSION

In recent years, domestic experts and scholars have done a lot of researches on the topic of entrepreneurship education, and have achieved some results. Han, Huiling, and Li (2017) proposed the innovative practice education system construction idea named "five in one". They believe that establishing the "five in one" entrepreneurship



**Figure 2.** Model of engineering-oriented talents entrepreneurship education

education system, which is policy support, curriculum-based, project-driven, yard support and multiple communication, will be helped. The “five in one” synthesizing the resources of class, school, social and international. And developed a knowledge system merged the professional education. It is of far-reaching significance to the construction of entrepreneurship education system in China. Jing and Zhanren (2017) proposed the “inner together and external connection” entrepreneurship education ecosystem. The “inner together” refers to that the universities and colleges put the institutes, teaching resources, research resources and practice platform and other factors together, to provide students with education, training and service systematically and pertinently. The “external connection” is to build a bridge between the universities and government, the enterprises and society, to provide guarantee and service for the development of entrepreneurship education and entrepreneurship activities. They are drawing on the successful experience of foreign countries. And paying attention to the subjective and objective conditions of entrepreneurship. But they just put forward an overall framework, without specific implementation process. Such as the description on how to construct the curriculum system. We agree that in the composition of college students’ entrepreneurial ability, the top four are the professional knowledge, practical experience, innovative ability and management ability. In order to start a business, the entrepreneur must be professional both in majors and entrepreneurial knowledge. Therefore, for the entrepreneurship education of engineering applied talents, it is particularly important to have a training plan which can be referred to. According to the model of engineering ability training proposed by our country’s scholar (Tianlong, 2011), we put forward the project of engineering-oriented talents entrepreneurship education, as shown in **Figure 2**.

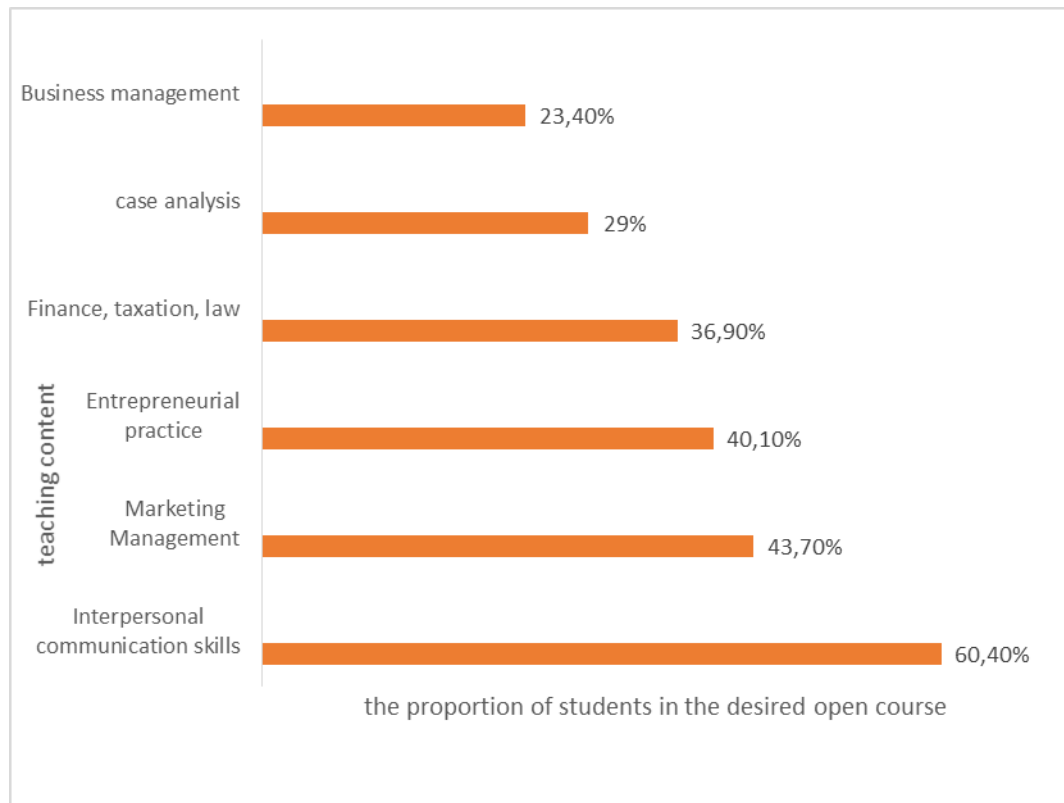
On the basis of the above research, this paper puts forward the following suggestions on the construction of the entrepreneurship education system for engineering applied talents.

### Improving the Structure of Teachers

As one of the three elements of education, teachers play a very important role in the whole educational activities. At present, the teachers of entrepreneurship education in local colleges and universities are mostly teachers in administrative positions. They don’t know much about entrepreneurship and students’ expertise. Therefore, in order to help students start their own business and improve their entrepreneurial ability, colleges and universities must pay attention to the teaching staffs of entrepreneurship education. Colleges and universities should dedicate to introduce entrepreneurs who are associated with engineering majors.

### Improving the Curriculum System

According to the statistical chart which is about college students’ expectation on entrepreneurship courses published by Tencent, as shown in **Figure 3**, we propose to increase the basic courses of entrepreneurship



**Figure 3.** Students' expectation statistics on entrepreneurship courses

education, such as economics, management, and other related courses in economics and management. Laying the knowledge foundation of entrepreneurship for students who are potential entrepreneurs and also unearthing the students' entrepreneurial awareness and enthusiasm. After two years of study, students have a certain understanding of their professional and entrepreneurial foundations. Therefore, the "project driven" curriculum can be used to encourage students to combine professional knowledge with entrepreneurial knowledge and theory with practice.

### Carrying out Outdoor Activities for Quality Development

Entrepreneurship is a tough process. It requires entrepreneurs not only to be tough, but also strong. Most of the students now do not suffer any bitter, life is also relatively leisurely. Most of them lack the spirit of hard work, perseverance and so on. While, in the process of entrepreneurship, regardless of the psychological and physical which first collapsed, will lead to the failure of entrepreneurship. Therefore, it is necessary to set up outdoor quality development activities.

### Vigorously Support Innovation and Entrepreneurship Projects

Colleges and universities should set up special funds to support students to do innovative project experiments. For engineering application majors, the most ideal business is technological entrepreneurship. And innovation project is a common way for engineering applied talents to realize technological innovation.

#### Building a bridge for students' Entrepreneurship

Only in the enterprise can the value of technology be maximized. Therefore, when students make progress in innovative projects, colleges and universities should build channels for students to communicate or cooperate with enterprises.

## CONCLUSION AND RECOMMENDATION

After studying a large number of academic works on entrepreneurship education both at home and abroad, this paper analyzes and summarizes the shortcomings of entrepreneurship education of engineering applied talents in China. And through the methods of literature research and questionnaire survey, this paper builds an

entrepreneurship training program for application-oriented talents. Based on that, this paper puts forward some strategies for the construction of the entrepreneurship education system for engineering applied talents in local colleges and universities. In practice, we should combine entrepreneurial education with professional education of engineering talents instead of entrepreneurship education or engineering education. Only in this way can we meet the development needs of our country and the individual needs of our students.

## ACKNOWLEDGEMENTS

This article is the employment and entrepreneurial management project of “the 13th Five-Year Plan” in Jilin Province Department of Education :Research on the entrepreneurship training path of engineering applied talents in the field of the “outstanding engineers education training plan”(project number: JJKH20170094JY) and Beihua University projects: periodically research productions of “Internet plus education” research on training mode of innovative talents (project number: YB201620) under these circumstances of big data age.

## REFERENCES

- Bo, Z. (2017). Research on Cultivation Scheme Based on TPB of Entrepreneurial Talents in Chinese Local Application-Oriented Universities. *EURASIA Journal of Mathematics Science and Technology Education*, 13(8), 5629-5636. <https://doi.org/10.12973/eurasia.2017.01016a>
- Chang, W.-L., & Chen, S.-T. (2015). The impact of World Cafe on entrepreneurial strategic planning capability. *Journal of Business Research*, 68(6), 1283-1290. <https://doi.org/10.1016/j.jbusres.2014.11.020.68>
- Feng, G., Hengliang, Y., Dongmei, G., & Yuelong, Y. (2011). A comparative study of entrepreneurship education between Chinese and Japanese College Students. *Innovation and Entrepreneurship Education*, 6, 89-93. <https://doi.org/10.3969/j.issn.1674-893X.2011.06.026>
- Guerrero, M., Cunningham, J. A., & Urbano, D. (2015). Economic impact of entrepreneurial universities' activities: An exploratory study of the United Kingdom. *Research Policy*, 44(3), 748-764. <https://doi.org/10.1016/j.respol.2014.10.008>
- Han, W., Huiling, Z., & Li, G. (2017). “Five in one” innovation and entrepreneurship practice education system analysis. *Beijing Education (Higher Education Edition)*, 3, 61-63. <https://doi.org/10.3969/j.issn.1000-7997.2017.02.021>
- Jing, C., & Zhanren, W. (2017). Research on the Construction of Entrepreneurship Education Ecosystem in the way of “inner together and external connection”. *The party building and Ideological Education in Schools*, 7, 71-74. <https://doi.org/10.3969/j.issn.1007-5968.2017.07.019>
- Lin, S., & Si, S. (2014). Factors affecting peasant entrepreneurs' intention in the Chinese context. *International Entrepreneurship and Management Journal*, 10(4), 803-825. <https://doi.org/10.1007/s11365-014-0325-4>
- Tianlong, G. (2011). Construction of practical education system for application oriented Talents. *Experimental technology principle*, 28(12), 1-4. <https://doi.org/10.3969/j.issn.1002-4956.2011.12.001>
- Ting, S. X., Feng, L., & Qin, W. (2017). The effect of entrepreneur mentoring and its determinants in the Chinese context. *Management Decision*, 55(8), 1410-1425. <https://doi.org/10.1108/MD-07-2016-0477>
- Yongbo, J., Bing, X., Haifei, L., & Min, F. (2017). Research on evaluation system construction of College Students' innovation and entrepreneurship. *Modern business*, 03, 187-189. <https://doi.org/10.14097/j.cnki.5392/2017.03.106>
- Zhang, Y., Duysters, G., & Cloudt, M. (2014). The role of entrepreneurship education as a predictor of university students' entrepreneurial intention. *International Entrepreneurship and Management Journal*, 10(3), 623-641. <https://doi.org/10.1007/s11365-012-0246-z>
- Zhu, H.-B., Zhang, K., & Ogbobo, U. S. (2017). Review on Innovation and Entrepreneurship Education in Chinese Universities during 2010-2015. *EURASIA Journal of Mathematics Science and Technology Education*, 13(8), 5939-5948. <https://doi.org/10.12973/eurasia.2017.01042a>

<http://www.ejmste.com>



For print copies of this issue or articles please send an e-mail to:

[print@modestum.co.uk](mailto:print@modestum.co.uk)



# The Relationship between Learning Orientation and Dynamic Capability based on Environmental Education

Xin He <sup>1</sup>, Shi-Zheng Huang <sup>2\*</sup>, Kou Zhao <sup>1</sup>, Xia Wu <sup>1</sup>

<sup>1</sup> School of Management, Lanzhou University, Lanzhou, Gansu, CHINA

<sup>2</sup> School of Economics and Management, Guangdong University of Petrochemical Technology, Maoming, CHINA

Received 4 October 2017 • Revised 7 January 2018 • Accepted 28 February 2018

## ABSTRACT

In the knowledge-based economy era, new firms need dynamic capability to adapt to the rapidly changing environment with increasing uncertainties in the competitive environment. A lot of researchers concern about the significant effects of knowledge accumulation on capability enhancement, systematic research on the effect of organizational learning on dynamic capability is still short. With questionnaire survey, 223 enterprises established within the past 8 years are selected as the research subjects for exploring the relationship among learning orientation, ambidextrous learning, and dynamic capability as well as testing the moderation effect of environmental uncertainty. The results reveal positive effects of learning orientation on dynamic capability, partial mediation of exploratory learning (exploitative learning) on learning orientation to dynamic capability, and moderated-mediation of environmental uncertainty on the exploratory learning (exploitative learning) to learning orientation-dynamic capability. The research proves the function of learning orientation to dynamic capability and provides beneficial inspiration for new firms promoting dynamic capability.

**Keywords:** new firm, learning orientation, ambidextrous learning, dynamic capability, environmental uncertainty

## INTRODUCTION

In the knowledge-based economy era, the increasing uncertainties in the competitive environment have new firms with short resources and insufficient competence encounter greater challenge (Goodman, 2011). For the survival, new firms stress on learning and innovation and the dynamic capability and development speed are higher than general enterprises. The organizational competence promoted through creative learning would affect the overall competitive advantage through product, process, and service innovation. Researchers proposed that an enterprise could absorb new knowledge through internal/external learning to enhance other capabilities (Christensen, 1995; Clammer, 2009; Drucker, 1985). It is a practice difficulty in new firms' survival and continuous development to accumulate knowledge, update knowledge, and construct the core competence. It is also the research focus in academia.

Teece and Pisano (1994) proposed dynamic capability as a key source of an enterprise forming competitive advantages (Teece, Pisano, & Shuen, 1997). Teece (1997) defined dynamic capability as the ability of an enterprise integrating, establishing, and reconstructing internal/external resources. Current research on dynamic capability focuses on two dimensions, including the effect of dynamic capability on corporate performance or competitive advantage (Fainshmidt, Pezeshkan, Lance Frazier, Nair, & Markowski, 2016; Teece, 2007; Zott, 2003) and the effects of entrepreneurial orientation, strategic orientation, and knowledge or relationship network on dynamic capability (Blyler & Coff, 2003; Helfat & Peteraf, 2015; Hodgkinson & Healey, 2011; Monteiro, Soares & Rua, 2017). Nevertheless, learning orientation is normally informal and non-linear in new firms and does not construct a system or is incomplete among other variables. Current research does not completely explain the dynamic capability

#### Contribution of this paper to the literature

- A new firm should devote to constructing the organizational culture with common vision, open mind, and commitment to learning and broadly spread such learning culture into individuals, teams, and the organization to enhance the dynamic capability.
- Exploratory learning and exploitative learning behaviors are affected by internal learning atmosphere of a new firm, i.e. learning orientation.
- A learning-oriented organizational culture is mediated by ambidextrous learning to enhance a new firm's dynamic capability.

construction process, and the effect of learning orientation on corporate dynamic capability has not obtained a systematic theory and empirical study.

It is expected to complete the theoretical influence mechanism on new firms' dynamic capability, enrich the practice of organizational learning theory under different cultural background, and provide practical reference for new firms, under the situation in China, promoting dynamic capability through learning.

## LITERATURE REVIEW AND THEORETICAL HYPOTHESIS

### Effects of Learning Orientation on Dynamic Capability

Learning orientation, being an important learning value and culture, is a primary drive of organizational learning behaviors and affects the capability of an organization absorbing, integrating, and creating resources (Baker & Sinkula, 1999; Guàrdia, Freixa, Peró, Turbany, Coscolluela, Barrios, & Rifà, 2006). Some researchers also study the effects of learning orientation on organizational performance or new firms' competitive advantage through the mediation effects of knowledge innovation, team trust, product innovation, and knowledge integration (Baba, 2015; Haryanto, Haryono, & Sawitri, 2017; Huang & Li, 2017; Mahmoud & Yusif, 2012; Sikora, Nybakk, & Panwar, 2016; Wu, Tsai, & Tai, 2016).

Learning organization theory indicated that an enterprise had to enhance the innovation capability through constantly learning for the long-term survival and development under the competitive environment with high uncertainties (Çömlek, Kitapçı, Çelik & Özşahin, 2012; Guàrdia et al., 2006). Zollo and Winter (2002) regarded dynamic capability as the result of learning mechanism. In comparison with other enterprises, new firms encountered more uncertainties and the acquisition of knowledge and resources required organizational loop learning; the learning-oriented cultural atmosphere therefore became extremely important for new firms (Hung, Yang, Lien, Mclean, & Kuo, 2010). To fulfill the development, new firms had to absorb and cultivate new knowledge through commitment to learning, allowing the employees sharing the responsibility with the enterprise through organizational vision, advancing the devotion, and contributing new ideas with creative and open mind to enhance the capability of the organization adapting to external environment (Gomes & Wojahn, 2017).

Managers and employees of new firms, from dynamic aspect, integrate resources to enhance the organizational learning ability and the capabilities of sensing external environment changes and coping with risks. In fact, learning orientation drives an enterprise actively pursuing new knowledge and challenging current situations to enhance the innovation capability. The above analyses reveal the critical function of learning orientation for an enterprise keeping matching with dynamic environment (Sirmon, Hitt, & Ireland, 2007). Consequently, it is considered in this study that learning-oriented cultural atmosphere in an organization might benefit the enterprise acquiring and promoting dynamic capability. Especially, rooted learning orientation might assist new firms, which present insufficient resources and capability, in the continuous survival in the uncertain environment. The following hypothesis is therefore proposed in this study.

**H1:** New firms' learning orientation presents positive effects on dynamic capability.

### Effects of Learning Orientation on Ambidextrous Learning

March (1991) first proposed the balance of exploitative learning and exploratory learning when studying the problems of organizational adaptability and development. Exploratory learning was the learning behavior of new knowledge trial and test; exploitative learning, on the other hand, was the learning behavior to conclude and sublimate existing knowledge in the organization, i.e. deepening the knowledge which presented significant meaning on the survival of the organization. Research revealed that a learning-oriented organization with common vision, open mind, and commitment to learning would show the following characteristics. The members presented common vision to induce the learning intention to further expand the ambidextrous learning (exploitative learning, exploratory learning) of the enterprise; and, open mind would advance the internal communication & exchange

and mutual correction in the organization (Baker & Sinkula, 1999; Mahmoud, Blankson, Owusu-Frimpong, Nwankwo, & Trang, 2015).

The development of ambidextrous learning and the function is affected by learning orientation. An enterprise could make progress through learning and even create innovative changes (Lin, Peng, & Kao, 2008; Maggioni & Roncari, 2009). When learning orientation enhances an enterprise thoroughly utilizing the knowledge and resources for learning, it also promotes the exploratory learning (Swart, Kinnie & Lund, 2007). Exploratory learning stresses on the acquisition of new knowledge and reflects the intention of an enterprise constantly seeking for new knowledge and challenge (Kaya & Patton, 2011). Research discovered that learning orientation had enterprises stress more on exploratory learning and encourage organizational members "thinking outside a box" (Baker & Sinkula, 1999). With limited resources and capability, a new firm might pay more attention to the development of exploratory learning. Accordingly, the following hypotheses are proposed in this study.

**H2a:** New firms' learning orientation shows positive effects on exploratory learning.

**H2b:** New firms' learning orientation reveals positive effects on exploitative learning.

### Ambidextrous Learning as Mediator

Research showed that exploratory learning and exploitative learning could remarkably enhance the dynamic capability of an organization (Easterby-Smith & Prieto, 2008). Dröge, Claycomb, and Germain (2003) proved that learning orientation would enhance organizational learning and further advance new firms more effectively allocating resources and constantly enhancing knowledge management capability. Learning orientation was a key factor in organizational learning as well as the capability to affect an organization absorbing, integrating, and creating resources. Teece and Leih (2016) indicated that dynamic capability required the accumulation of organizational learning, but could not directly acquire externally. Learning was the major mechanism to create and develop dynamic capability (Zollo & Winter, 2002), which was developed through repeated practice, records, mistakes, continuous learning, and experience accumulation.

In comparison with mature enterprises, new firms' ambidextrous learning appears more remarkable effects on organizational resources and capability. On one hand, the exploration and exploitation of external knowledge present extremely importance on new firms' promotion of existing resources and recreation of new resources. On the other hand, the characteristic of "new" reflects that existing knowledge of a new firm might not be able to satisfy the current development, but require the information and technology acquired through ambidextrous learning for transforming into organizational resources. It is considered in this study that learning orientation affects dynamic capability with ambidextrous learning as the mediator and the mediation effect of new firms' ambidextrous learning is significant. The following hypotheses are therefore proposed in this study.

**H3a:** Exploratory learning appears mediation effects between new firm learning orientation and dynamic capability.

**H3b:** Exploitative learning presents mediation effects between new firm learning orientation and dynamic capability.

### Moderation of Environmental Uncertainty

Environmental uncertainty refers to the unstable state of the external environment in which an enterprise is. Uncertain environment refers to fiercely external competitive environment and constantly changing customer needs (Teece, 2007). In the research on the root and mechanism of organizational learning, a lot of researchers regarded the changes of external environment as the cause of an enterprise' learning behavior that external environment was a key factor in organizational learning. An organization would reduce the learning intention and behavior when the environment is relatively stable, but enhance with increasing environmental uncertainty. High-level environmental uncertainty has the survival and development of an enterprise become more difficult that the enterprise has to make more efforts to enhance the dynamic capability so as to cope with such test. Under low-level environmental uncertainty, an enterprise with learning-oriented cultural atmosphere might not be aware of threats from the environment to keenly sense external opportunities and pay attention to the promotion of capabilities. For this reason, the following hypotheses are proposed in this study.

**H4a:** Environmental uncertainty shows positive moderation between learning orientation and dynamic capability.

**H4b:** Environmental uncertainty reveals positive moderation between learning orientation and exploratory learning.

**H4c:** Environmental uncertainty appears positive moderation between learning orientation and exploitative learning.

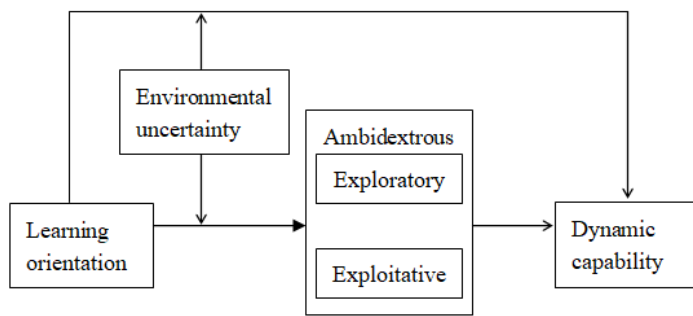


Figure 1. Theoretical model

The previous hypotheses infer the mediation effects of exploratory learning and exploitative learning between learning orientation and dynamic capability; meanwhile, environmental uncertainty positively advances the effect of learning orientation on ambidextrous learning and dynamic capability. In this case, it is necessary to test whether the mediation effect of ambidextrous learning on learning orientation→dynamic capability is moderated by environmental uncertainty. The following hypotheses are further proposed in this study.

- H5a:** Environmental uncertainty presents moderated-mediation on exploratory learning between learning orientation and dynamic capability.
- H5b:** Environmental uncertainty shows moderated-mediation on exploitative learning between learning orientation and dynamic capability.

## RESEARCH DESIGN

### Research Sample and Data Collection

The research data are acquired from new firms, which are established within 8 years, in the eastern, western, and central China, and the top and middle managers are surveyed with the questionnaire. Total 400 copies of questionnaire are distributed, and 256 copies are collected. Deducting 33 copies with incomplete information, 223 valid copies are retrieved, with the retrieval rate 55.75%. Among the 223 enterprises, the firm size shows 10.31% with 1-10 employees, 16.14% with 11-50 employees, 12.56% with 51-100 employees, and 60.99% with more than 100 employees. The firm age reveals 3.14% enterprises being established within 1 year, 13.00% in 1-3 years, 15.70% in 3-5 years, and 68.16% in 5-8 years. The industry belonged shows 35.00% of manufacturing, 10.31% of information transmission, software and information technology service, 15.70% of finance, 3.60% of transport, warehouse, and post, 6.73% of wholesale and retail, 7.17% of building, 2.70% of real estate & accommodation and food service, and 16.09% of others.

### Measurement of Variable

The questionnaire in this study is developed by referring to previous theories and relevant literatures. For the conscientiousness, 30 enterprises are selected for the questionnaire pretest to ensure the accuracy, adaptability, and convenience. The formal questionnaire is completed after repeatedly revising unsuitable semantic meanings. The questionnaire is measured with Likert 5-point scale and contains four dimensions of learning orientation, ambidextrous learning, dynamic capability, and environmental uncertainty. The operational definitions and measurement of variables in the research structure as well as the reference for research scales are explained as below.

The measurement of learning orientation combines the scales developed by Sinkula et al. (1997) and Farrell and Mavondo (2004), including three dimensions of commitment to learning, common vision, and open mind. Each dimension contains 3 questions and the Cronbach'  $\alpha$  coefficient of the scale appears 0.858. The measurement of exploratory learning and exploitative learning combines the scales developed by Atuahene-Gima and Murray (2007) and Su, Li, Yang, and Li (2011), and 3 questions are adopted. The Cronbach'  $\alpha$  coefficients of exploratory learning and exploitative learning are 0.760 and 0.841, respectively. Referring to Teece (2007), sensibility, acquisition capability, and reconstruction capability are covered for measuring dynamic capability. Based on the scale developed by Wilden, Gudergan, Bo, and Lings (2013), 12 questions are covered and the Cronbach'  $\alpha$  coefficient presents 0.920. Referring to Miller and Friesen (1983) and Tan and Litschert (1994), two dimensions of dynamic and hostile, total 6 questions, are used for measuring environmental uncertainty. The Cronbach'  $\alpha$  coefficients appear

**Table 1.** Mean, standard deviation, and correlation coefficient matrix of variable

Variable	Mean	Standard deviation	1	2	3	4	5	6	7	8
1 learning orientation	3.810	0.611	1							
2 exploratory learning	3.550	0.762	0.594**	1						
3 exploitative learning	3.528	0.751	0.489**	0.614**	1					
4 dynamic capability	3.788	0.616	0.667**	0.707**	0.635**	1				
5 environmental uncertainty	2.986	0.802	0.159*	0.214**	0.243**	0.282**	1			
6 industry	3.830	2.945	0.051	0.027	-0.12	-0.039	-0.011	1		
7 size	3.240	1.063	-0.215**	-0.238**	-0.198**	-0.204**	0.001	-0.102	1	
8 age	3.490	0.838	-0.071	-0.068	-0.109	-0.076	-0.085	-0.140*	0.635**	1

Note: N=223; \* $p < .05$ ; \*\* $p < .01$ ; \*\*\* $p < .001$  (two-tailed test)

0.764 and 0.799, respectively. Furthermore, the number of employees is generally used for measuring firm size. Enterprises with different sizes would present distinct learning methods. Firm age, firm size, and industry belonged are therefore selected as control variables in this study (Wu, Tsai, & Yeh, 2014).

## EMPIRICAL RESULT AND ANALYSIS

### Descriptive Statistics and Common Method Variance Bias

SPSS23.0 and AMOS24.0 are used in this study for the statistical analyses of data. The mean, standard deviation, and correlation coefficient of variables are shown in **Table 1**, in which the correlation coefficients of learning orientation, exploratory learning, exploitative learning, dynamic capability, and environmental uncertainty appear in 0.16-0.71, achieving the significance. It reveals the moderately positive correlation between various dimensions and dynamic capability.

Harman’s single factor method is used for solving the Common Method Variance bias. From the analysis of the entire questionnaire, the first factor, without rotation, explains 35.8% variance, showing that the Common Method Variance bias would not affect the research result.

Confirmatory Factor Analysis is utilized for testing the reliability, convergent validity, discriminant validity, and model fit of the questionnaire to understand the consistency between the hypothesis model and the observed data. The Confirmatory Factor Analysis result reveals the model fit reaching the standard ( $df=1.98$  ( $p < 0.001$ ),  $RMR=0.046$ ,  $CFI=0.910$ ,  $IFI=0.911$ , and  $RMSEA=0.067$ ) that the questionnaire presents better reliability and validity, with good fit.

### Hypothesis Test

#### Main effect and mediation effect

Multiple Regression Analysis is used for the test in this study. In **Table 2**, Model 2 reveals the significant effects of learning orientation on dynamic capability ( $r=0.656$ ,  $p < 0.001$ ) that H1 is proved. Model 8 presents the remarkably positive effects of learning orientation on exploratory learning ( $r=0.564$ ,  $p < 0.001$ ) that H2a is supported. Similarly, Model 12 shows the notable effects of learning orientation on exploitative learning ( $r=0.476$ ,  $p < 0.001$ ) that H2b is supported. Model 4 reveals significant coefficients of learning orientation, exploratory learning, and exploitative learning, i.e. partial mediation effects of exploratory learning and exploitative learning on learning orientation and dynamic capability, that H3a and H3b are proved.

**Table 2.** Hierarchical Regression Analysis result

Variable	Dynamic capability					Exploratory learning					Exploitative learning			
	Model1	Model2	Model3	Model4	Model5	Model6	Model7	Model8	Model9	Model10	Model11	Model12	Model13	Model14
control variable														
industry	-0.054	-0.079	-0.016	-0.037	-0.073	-0.072	0.014	-0.008	-0.004	0.000	-0.141*	-0.159**	-0.155**	-0.152**
size	-0.262**	-0.076	-0.027	0.004	-0.102	-0.106	-0.326***	-0.166*	-0.185*	-0.191*	-0.220*	-0.085	-0.108	-0.114
age	0.083	0.008	0.008	-0.009	0.038	0.037	0.141	0.076	0.099	0.096	0.011	-0.043	-0.016	-0.018
parameter														
learning orientation		0.656***		0.337***	0.623***	0.602***		0.564***	0.540***	0.505***		0.476***	0.446***	0.416***
mediator														
exploratory learning			0.507***	0.357***										
exploitative learning			0.317***	0.246***										
moderator														
environmental certainty					0.186***	0.164**			0.136*	0.098			0.169**	0.137**
interaction						0.111*				0.193***				0.163**
R <sup>2</sup>	0.049	0.456	0.565	0.635	0.489	0.500	0.068	0.369	0.387	0.421	0.059	0.274	0.301	0.326
ΔR <sup>2</sup>	0.036	0.446	0.555	0.625	0.477	0.486	0.055	0.358	0.373	0.405	0.046	0.260	0.285	0.307
F	3.777*	45.615***	56.396***	62.559***	41.474***	36.009***	5.343***	31.928***	27.413***	26.208***	4.608**	20.547***	18.712***	17.392***

Note: N=223; \*p<.05; \*\*p<.01; \*\*\*p<.001 (two-tailed test)

Bootstrap is utilized for testing the significance of mediation effects. Setting the macro test of 5000 times of mediation effects with Bootstrap, the learning orientation-exploratory learning-dynamic capability Sobel test shows the remarkably indirect effect 0.203 (Z=4.765, p<0.001). It reveals that 95% confidence interval (CI) of above indirect effect is [0.128, 0.296], where 0 is not included. The indirect effect is therefore significant. The learning orientation-exploitative learning-dynamic capability Sobel test appears the indirect effect 0.118 (Z=3.568, p<0.001), achieving the significance. The Bootstrap test shows that 95% confidence interval (CI) of above indirect effect is [0.063, 0.197], in which 0 is not included, that the indirect effect is significant.

### Test of moderation effect

The test result of moderation effect is shown in Table 2. Model 6 presents the remarkable coefficient of the product of learning orientation and environmental uncertainty (r=0.111, p<0.05), showing the notable moderation effect of environmental uncertainty on learning orientation and dynamic capability that H4a is supported. Model 10 reveals the notable coefficient of the product (r=0.193, p<0.001), explaining the significant moderation effect of environmental uncertainty on learning orientation and exploratory learning that H4b is supported. Model 14 presents the remarkable coefficient of the product (r=0.163, p<0.01), revealing the significant moderation effect of environmental uncertainty on learning orientation and exploitative learning that H4c is supported.

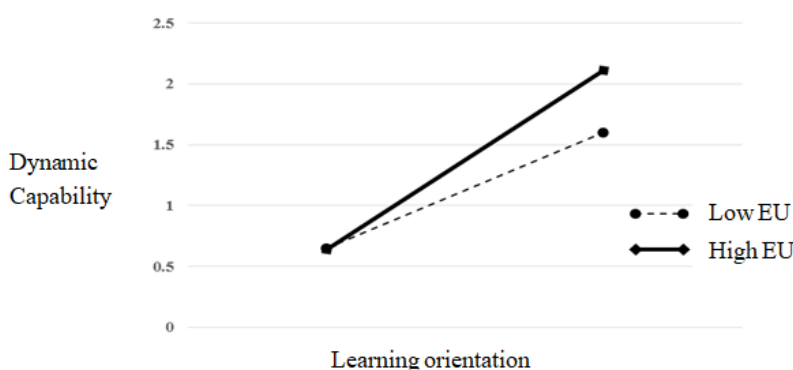
To test moderated-mediation effects, according to the suggestion of Edwards and Lambert (2007), setting the macro test of 5000 times of indirect effects with Bootstrap, the results are shown in Table 3. From Table 3, when environmental uncertainty appears the lower level (mean-1 standard deviation), learning orientation shows notable effects on dynamic capability through exploratory learning (r=0.117, p<0.001). The confidence interval (CI) is [0.040, 0.198], in which 0 is not included. When environmental uncertainty presents higher level (mean+1 standard deviation), learning orientation shows effects on dynamic capability through exploratory learning (r=0.237, p<0.001). The confidence interval (CI) is [0.131, 0.372], where 0 is not included. As a result, in comparison with low-level environmental uncertainty, exploratory learning presents stronger mediation effects between learning orientation and dynamic capability when higher-level environmental uncertainty appears. H5a is therefore supported. Similarly, learning orientation shows remarkable effects on dynamic capability through exploitative learning (r=0.060, p<0.001) when there is lower-level environmental uncertainty (mean-1 standard deviation). The confidence interval (CI) is [0.016, 0.132], where 0 is not included. When the level of environmental uncertainty is high (mean+1 standard deviation), learning orientation presents notable effects on dynamic capability through exploitative learning (r=0.131, p<0.001). The confidence interval (CI) appears [0.060, 0.241], where 0 is not included. It is therefore considered that exploitative learning shows stronger mediation effects between learning orientation and dynamic capability when higher-level environmental uncertainty appears that H5b is supported. To present the mediation effects of exploratory learning and exploitative learning under different environmental uncertainty levels, the relationship between learning orientation and dynamic capability is shown in Figure 2. When exploratory learning and exploitative learning are mediators, the stronger relationship appears between learning orientation and dynamic capability with the higher environmental uncertainty level.



**Table 3.** Mediation effects and the confidence interval of Bootstrap on different moderator standards

	environmental	dynamic capability			
	uncertainty	indirect effects	SE	LLCI	ULCI
exploratory learning	2.184	0.117***	0.040	0.040	0.198
exploratory learning	2.986	0.175***	0.039	0.104	0.261
exploratory learning	3.788	0.237***	0.060	0.131	0.372
exploitative learning	2.184	0.060***	0.029	0.016	0.132
exploitative learning	2.986	0.096***	0.030	0.047	0.166
exploitative learning	3.788	0.131***	0.044	0.060	0.241

Note: N=223; \* $p < .05$ ; \*\* $p < .01$ ; \*\*\* $p < .001$  (two-tailed test)



**Figure 2.** Learning orientation and dynamic capability: moderation of environmental uncertainty

## RESEARCH CONCLUSION AND OUTLOOK

### Result Discussion

The theoretical model of learning orientation and dynamic capability in this study is constructed based on organizational learning theory to propose relevant hypotheses, and new firms in China, the developing country, are regarded as the research objects. The research is concluded as followings.

First, learning orientation could effectively drive new firms forming dynamic capability. A new firm should devote to constructing the organizational culture with common vision, open mind, and commitment to learning and broadly spread such learning culture into individuals, teams, and the organization to enhance the dynamic capability. It explains a new firm's timely sensing external opportunities and risks, grasping opportunities, and timely adjusting and integrating resources. Second, exploratory learning and exploitative learning behaviors are affected by internal learning atmosphere of a new firm, i.e. learning orientation. The cognition of the importance of learning culture could promote an enterprise's exploratory learning and exploitative learning. Third, a learning-oriented organizational culture is mediated by ambidextrous learning to enhance a new firm's dynamic capability. For a new firm, exploratory learning presents more significantly positive effects on dynamic capability than the effect of exploitative learning on dynamic capability. It explains the critical effect of exploratory learning on a new firm forming dynamic capability. Fourth, environmental uncertainty positively moderates the relationship between learning orientation and dynamic capability as well as the relationship between learning orientation and exploratory learning, exploitative learning. Moreover, the moderation of environmental uncertainty on the relationship between organizational learning culture and learning behavior is especially remarkable. When external environmental uncertainty appears high level, the ambidextrous learning behavior of an organization is active; otherwise, the ambidextrous learning behavior is inhibited. Research also finds out the moderation of environmental uncertainty on exploratory learning behavior, which is more significant than the moderation on exploitative learning. It might be determined by a new firm's characteristics. Fifth, the mediation effect of ambidextrous learning between learning orientation and dynamic capability is moderated by environmental uncertainty. When environmental uncertainty is enhanced, the mediation effect of either exploratory learning or exploitative learning is enhanced. Sixth, the survey data reveal that increasing firm size would reduce an organization's learning orientation, ambidextrous learning behavior, and dynamic capability. It is an important alert for entrepreneurs that organizational learning culture, learning behavior protection mechanism, and dynamic capability should be emphasized when expanding the firm size.

### Theoretical Contribution

The major theoretical contribution of this study is summarized as below. First, organizational learning theory and dynamic capability theory are integrated, and learning orientation and ambidextrous learning are applied to entrepreneurship to explain the effects from learning orientation to dynamic capability that an enterprise should pay attention to the cultivation of learning orientation atmosphere, and develop organizational learning culture. Second, from the aspect of organizational learning, exploratory learning and exploitative learning, as mediators, are included in the model to study the effect of learning orientation on dynamic capability through ambidextrous learning. Sorting out organizational culture and enriching learning orientation and the result as well as the mutual function through the route of organizational behavior driving dynamic capability instruct a new firm constructing the dynamic capability. Finally, new firms are selected as the research objects because they appear larger differences from mature enterprises, under static and dynamic environment. New firms require the support of new resources that environment uncertainty shows larger function on the learning activity and dynamic capability. By introducing environmental uncertainty as the moderator, the empirical analysis reveals the significant moderation of environmental uncertainty to enrich the theoretical model as well as provide theoretical supports of timely, positive, and active exploratory learning and exploitative learning for new firms, under the turmoil environment.

### Research Restriction and Future Outlook

This study presents the following shortage. (1) Although sample structure is taken into account for the selection of samples, the number of effective samples is limited that the research result might exist in bias. (2) Exploratory learning and exploitative learning are taken as mediators for the research on effects on learning orientation and dynamic capability. The result proves partial mediation effects of exploratory learning and exploitative learning between learning orientation and dynamic capability. It implies that there might be other variables with mediation effects between learning orientation and dynamic capability. In this case, successive research should further dig out various potential mediators to more completely disclose the internal mechanism between the two. (3) Environmental uncertainty is regarded as the moderator in this study. The results prove the moderation of environmental uncertainty between learning orientation, ambidextrous learning and dynamic capability. The future research could take environmental uncertainty as the antecedent to study the effect of environmental uncertainty on an organization's learning orientation and dynamic capability. (4) Ambidextrous learning covers individuals, teams, and the organization. This study merely discusses organizational ambidextrous learning. The future research could thoroughly discuss the relationship among learning orientation, ambidextrous learning, and dynamic capability of an enterprise from different aspects to comprehensively understand the effect of learning orientation on dynamic capability in a new firm.

### ACKNOWLEDGEMENT

Supported by "the Fundamental Research Funds for the Central Universities" (16LZUJBWZD001), "Guangdong Social Science Planning Project" (GD17XGL15).

### REFERENCES

- Atuahene-Gima, K., & Murray, J. Y. (2007). Exploratory and exploitative learning in new product development: a social capital perspective on new technology ventures in China. *Journal of International Marketing*, 15(2), 1-29. <https://doi.org/10.1509/jimk.15.2.1>
- Baba, Y. (2015). Does learning orientation matter for nonprofit organization performance? Empirical evidence from Ghana. *Leadership & Organization Development Journal*, 36(3), 234-252. <https://doi.org/10.1108/LODJ-05-2013-0056>
- Baker, W. E., & Sinkula, J. M. (1999). The synergistic effect of market orientation and learning orientation on organizational performance. *Journal of the Academy of Marketing Science*, 27(4), 411-427. <https://doi.org/10.1177/0092070399274002>
- Blyler, M., & Coff, R. W. (2003). Dynamic capabilities, social capital, and rent appropriation: ties that split pies. *Strategic Management Journal*, 24(7), 677-686. <https://doi.org/10.1002/smj.327>
- Christensen, J. F. (1995). Asset Profiles for Technological Innovation. *Research Policy*, 24(5), 727-745. [https://doi.org/10.1016/0048-7333\(94\)00794-8](https://doi.org/10.1016/0048-7333(94)00794-8)
- Clammer, J. (2009). Sociology and beyond: towards a deep sociology. *Asian Journal of Social Science*, 37(3), 332-346. <https://doi.org/10.1163/156853109X436757>

- Çömlek, O., Kitapçı, H., Çelik, V., & Özşahin, M. (2012). The effects of organizational learning capacity on firm innovative performance. *Procedia - Social and Behavioral Sciences*, 41(41), 367-374. <https://doi.org/10.1016/j.sbspro.2012.04.043>
- Dröge, C., Claycomb, C., & Germain, R. (2003). Does knowledge mediate the effect of context on performance? Some initial evidence. *Decision Sciences*, 34(3), 541-568. <https://doi.org/10.1111/j.1540-5414.2003.02324.x>
- Drucker, P. (1985). *Innovation and Entrepreneurship*. New York: Harper and Row.
- Easterby-Smith, M., & Prieto, I. M. (2008). Dynamic capabilities and knowledge management: an integrative role for learning? *British Journal of Management*, 19(3), 235-249. <https://doi.org/10.1111/j.1467-8551.2007.00543.x>
- Edwards, J. R., & Lambert, L. S. (2007). Methods for integrating moderation and mediation: a general analytical framework using moderated path analysis. *Psychological Methods*, 12(1), 1. <https://doi.org/10.1037/1082-989X.12.1.1>
- Fainshmidt, S., Pezeshkan, A., Lance Frazier, M., Nair, A., & Markowski, E. (2016). Dynamic capabilities and organizational performance: a meta-analytic evaluation and extension. *Journal of Management Studies*, 53(8), 1348-1380. <https://doi.org/10.1111/joms.12213>
- Farrell, M., & Mavondo, F. T. (2004). The effect of downsizing strategy and reorientation strategy on a learning orientation. *Personnel Review*, 33(4), 383-402. <https://doi.org/10.1108/00483480410539470>
- Gomes, G., & Wojahn, R. M. (2017). Organizational learning capability, innovation and performance: study in small and medium-sized enterprises (SMES). *Revista de Administração (São Paulo)*, 52(2), 163-175. <https://doi.org/10.1016/j.rausp.2016.12.003>
- Goodman, P. S. (2011). *Organizational learning contracts: new and traditional colleges*. Oxford: Oxford University Press. <https://doi.org/10.1093/acprof:oso/9780199738656.001.0001>
- Guàrdia, J., Freixa, M., Però, M., Turbany, J., Coscolluela, A., Barrios, M., & Rifà, X. (2006). Factors related to the academic performance of students in the statistics course in psychology. *Quality and Quantity*, 40(4), 661-674. <https://doi.org/10.1007/s11135-005-2072-7>
- Haryanto, A. T., Haryono, T., & Sawitri, H. S. R. (2017). Market orientation, learning orientation and small medium enterprises performance: the mediating role of innovation. *International Review of Management & Marketing*, 7.
- Helfat, C. E., & Peteraf, M. A. (2015). Managerial cognitive capabilities and the micro foundations of dynamic capabilities. *Strategic Management Journal*, 36(6), 831-850. <https://doi.org/10.1002/smj.2247>
- Hodgkinson, G. P., & Healey, M. P. (2011). Psychological foundations of dynamic capabilities: reflexion and reflection in strategic management. *Strategic Management Journal*, 32(13), 1500-1516. <https://doi.org/10.1002/smj.964>
- Huang, J. W., & Li, Y. H. (2017). The mediating role of ambidextrous capability in learning orientation and new product performance. *Journal of Business & Industrial Marketing*, 32(5), 613-624. <https://doi.org/10.1108/JBIM-01-2015-0017>
- Hung, R. Y. Y., Yang, B., Lien, Y. H., Mclean, G. N., & Kuo, Y. M. (2010). Dynamic capability: impact of process alignment and organizational learning culture on performance. *Journal of World Business*, 45(3), 285-294. <https://doi.org/10.1016/j.jwb.2009.09.003>
- Kaya, N., & Patton, J. (2011). The Effects of Knowledge-Based Resources, Market Orientation and Learning Orientation on Innovation Performance: An Empirical Study of Turkish Firms. *Journal of International Development*, 23(2), 204-219. <https://doi.org/10.1002/jid.1662>
- Lin, C., Peng, C., & Kao, D. T. (2008). The innovativeness effect of market orientation and learning orientation on business performance. *International Journal of Manpower*, 29(November), 752-772. <https://doi.org/10.1108/01437720810919332>
- Maggioni, M. A., & Roncari, S. N. (2009). Learning, innovation and growth within interconnected clusters: an agent-based approach. *Advances in Spatial Science*, 117-144. [https://doi.org/10.1007/978-3-540-70924-4\\_6](https://doi.org/10.1007/978-3-540-70924-4_6)
- Mahmoud, M. A., Blankson, C., Owusu-Frimpong, N., Nwankwo, S., & Trang, T. P. (2015). Market orientation, learning orientation and business performance: the mediating role of innovation. *International Journal of Bank Marketing*, 34(5), 623-648. <https://doi.org/10.1108/IJBM-04-2015-0057>
- Mahmoud, M.A., & Yusif, B. (2012). Market orientation, learning orientation, and the performance of nonprofit organisations (NPOs). *International Journal of Productivity and Performance Management*, 61(6), 624-652. <https://doi.org/10.1108/17410401211249193>
- March, J. G. (1991). Exploration and exploitation in organizational learning. *Organization Science*, 2(1), 71-87. <https://doi.org/10.1287/orsc.2.1.71>

- Miller, D., & Friesen, P. H. (1983). Strategy-making and environment: the third link. *Strategic Management Journal*, 4(3), 221-235. <https://doi.org/10.1002/smj.4250040304>
- Monteiro, A. P., Soares, A. M., & Rua, O. L. (2017). Linking intangible resources and export performance: the role of entrepreneurial orientation and dynamic capabilities. *Baltic Journal of Management*, 12(3). <https://doi.org/10.1108/BJM-05-2016-0097>
- Sikora, A. T., Nybakk, E., & Panwar, R. (2016). The effect of entrepreneurial and learning orientations on financial performance in a transition economy: evidence from forest contracting firms in southern poland. *Scandinavian Journal of Forest Research*, 31(1), 119-125. <https://doi.org/10.1080/02827581.2015.1079642>
- Sinkula, J. M., Baker, W. E., & Noordewier, T. (1997). A framework for market-based organizational learning: Linking values, knowledge, and behavior. *Journal of the Academy of Marketing Science*, 25(4), 305-318. <https://doi.org/10.1177/0092070397254003>
- Sirmon, D. G., Hitt, M. A., & Ireland, R. D. (2007). Managing firm resources in dynamic environments to create value: looking inside the black box. *Academy of Management Review*, 32(1), 273-292. <https://doi.org/10.5465/AMR.2007.23466005>
- Su, Z., Li, J., Yang, Z., & Li, Y. (2011). Exploratory learning and exploitative learning in different organizational structures. *Asia Pacific Journal of Management*, 28(4), 697-714. <https://doi.org/10.1007/s10490-009-9177-9>
- Swart, J., Kinnie, N., & Lund, M. (2007). Simultaneity of learning orientations in a marketing agency. *Management Learning*, 38(3), 20-22. <https://doi.org/10.1177/1350507607079033>
- Tan, J. J., & Litschert, R. J. (1994). Environment-Strategy Relationship and Its Performance Implications: An Empirical Study of the Chinese Electronics Industry. *Strategic Management Journal*, 15(1), 1-20. <https://doi.org/10.1002/smj.4250150102>
- Teece, D. J. (2007). Explicating dynamic capabilities: the nature and micro foundations of (sustainable) enterprise performance. *Strategic Management Journal*, 28(13), 1319-1350. <https://doi.org/10.1002/smj.640>
- Teece, D. J., & Leih, S. (2016). Uncertainty, innovation, and dynamic capabilities: an introduction. *California Management Review*, 58(4), 5-12. <https://doi.org/10.1525/cmr.2016.58.4.5>
- Teece, D. J., Pisano, G., & Shuen, A. (1997). Dynamic capabilities and strategic management. *Strategic Management Journal* 18(7), 509-533. [https://doi.org/10.1002/\(SICI\)1097-0266\(199708\)18:7<509::AID-SMJ882>3.0.CO;2-Z](https://doi.org/10.1002/(SICI)1097-0266(199708)18:7<509::AID-SMJ882>3.0.CO;2-Z)
- Teece, D., & Pisano, G. (1994). The Dynamic Capabilities of the Firm. *Industrial and Corporate Change*, 3, 538-556. <https://doi.org/10.1093/icc/3.3.537-a>
- Wilden, R., Gudergan, S. P., Bo, B. N., & Lings, I. (2013). Dynamic capabilities and performance: strategy, structure and environment. *Long Range Planning*, 46(1-2), 72-96. <https://doi.org/10.1016/j.lrp.2012.12.001>
- Wu, T. J., Tsai, H. T., & Tai, Y. N. (2016). Would corporate social responsibility affect consumers' attitudes towards brand and purchase behavior? Buyer-seller guanxi as the moderator. *Revista de Cercetare si Interventie Sociala*, 53, 272-287.
- Wu, T. J., Tsai, H. T., & Yeh, S. P. (2014). The role of manager's locus of control between perceived guanxi and leadership behavior in family business. *Revista Internacional de Sociologia*, 72(EXTRA2), 87-104. <https://doi.org/10.3989/ris.2013.08.11>
- Zollo, M., & Winter, S. G. (2002). Deliberate learning and the evolution of dynamic capabilities. *Organization Science*, 13(3), 339-351. <https://doi.org/10.1287/orsc.13.3.339.2780>
- Zott, C. (2003). Dynamic capabilities and the emergence of intraindustry differential firm performance: insights from a simulation study. *Strategic management journal*, 24(2), 97-125. <https://doi.org/10.1002/smj.288>

<http://www.ejmste.com>

## A Study on Lacquer Design Teaching via Digital Platform

Kuo-Kuang Fan<sup>1</sup>, Xue-Hui Li<sup>1\*</sup>, Meng-Jia Lu<sup>2</sup>

<sup>1</sup> National Yunlin University of Science and Technology, Graduate School of Design, YunLin, TAIWAN

<sup>2</sup> GuangZhou High School of Fine Arts, GuangZhou, CHINA

Received 23 October 2017 • Revised 6 February 2018 • Accepted 22 February 2018

### ABSTRACT

Lacquer art is the essence of Chinese culture; however the teaching of lacquer art is unpopular due to the complicated production process. There is little opportunity for primary and secondary school students to access relevant knowledge, and this has resulted in a weak foundation of Chinese lacquer art knowledge. This study researched the lacquer art teaching in primary and secondary education and exerted digital information resources to explore a new learning mode. This study measured the teaching outcomes and summarized the advantages and disadvantages of the teaching methods based on the author's participatory observations and students' after-class questionnaire feedback. The most significant aspect of the study was the hope that Chinese teenagers could have a comparatively early acquaintance of the cultural knowledge for lacquer art and provide more positive social factors for the inheritance and development of future lacquer design.

**Keywords:** design teaching, digital platform, lacquer design

## INTRODUCTION

### Research Background

Within the category of lacquer design teaching, courses are mostly presented in colleges and universities, and there is little lacquer teaching for students under those ages. There are three main factors for this: 1) due to the intensive arrangement of the main cultural courses, art courses are condensed, and it is difficult to realize independent class periods; 2) due to the enormous quantity of knowledge involved in lacquer art, expected teaching results cannot be achieved through traditional methods and classroom facilities; and 3) due to the high specialization of lacquer art, common teachers are not capable of taking over the class, while teachers who are knowledgeable in this field have been in short supply for a long time. In sum, it is mainly restricted by teaching time and classroom conditions, which has led to the long absence of traditional Chinese lacquer culture in primary and secondary school education and relatively low social cognition.

With the development of modern science and technology, according to the "Statistical Communiqué of the People's Republic of China on the 2016 National Economic and Social Development" (National Bureau of Statistics of China, 2017), the popularization rate of mobile telephones increased to 96.2 sets per hundred people and the internet population increased by 42.99 million people to 0.731 billion people, of which those accessing the internet via mobile phones increased by 75.50 million people to 0.695 billion people. Thus, it can be seen that there is increasing improvement in the popularization of networking and communications. The convenience of information transfer emancipates the constraint of time, strengthens flexibility and leads to variations in learning models, which has been regularly restricted in classrooms. Furthermore, the objective condition of aiding teaching via digital platform is mature, and the basic condition for strengthening lacquer design teaching using information technology has already been formed.



#### **Contribution of this paper to the literature**

- As for the lacquer teaching for middle and primary periods, the study probes into a new learning mode upon the flexibility and popularity of today's network and communication.
- This study achieved the initial comparative research between traditional teaching method and the mode of utilizing digital platform resources.
- As presented by the writer's teaching practice and students' questionnaire data, the lacquer teaching via digital platform obtains more satisfied teaching effects.

### **Research Purpose**

This study was carried out based on the current background condition of China's technological development from the perspective of a teaching-study researcher. The research purpose of this study was to explore a more flexible and interesting learning model via the information superiority of contemporary science and technology and the advanced equipment of digital platform to give primary and secondary school students access to information and to realize the charm and characteristics of lacquer culture, improve the aesthetic abilities, and further enhance the sense of national pride.

### **LITERATURE REVIEW**

In recent years, the art-design teaching in China features increasing popularization but still has some shortcomings. Among those, the more obvious issues are the deficient flexibility in outdated teaching method, short of special courses construction, neglect of traditional culture education, as well as the ignoring of creative thinking training in traditional close-end classroom teaching, which is the main status in quo. Not only the solid systematic basic training, but also the diversity of teaching mode should be focused during the course teaching of art design specialty (Zhu, 2014). The education of design in China has been emphasized on the skill training for a long period, thus generating the shortage of individual creative thinking ability. The emergence of computer enables the diversified development of design, while the traditional design mode is still under various restrictions and requirements (Jiang, 2013).

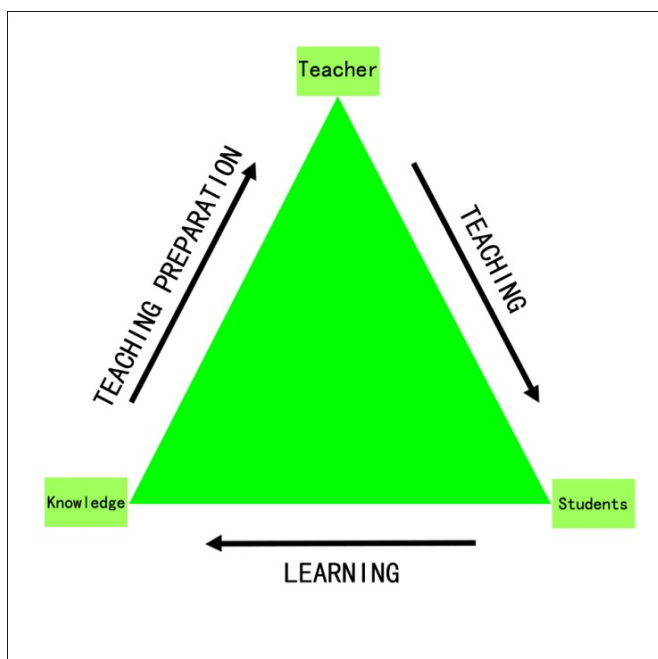
The increasing influence of computer technology has allowed it to become an effective way for teachers to achieve the combination of computer technology and teaching to enhance learning outcomes (Kirschner, 2015). Mobile digital devices with high popularization improve the variance of learning time, break the limits of traditional academic environments, and effectively maintain the potential learning consistency (Milrad et al., 2013). Practical explorations on aiding teaching via high-tech conditions have centered on design categories, such as construction, and exhibitions have been conducted and summarized (Salman, Laing, & Conniff, 2014). The application of digital science and technology into teaching, the influence of the computer's role in learning modes, and the advantages and disadvantages thereof have become key issues of study (Bernal & Eastman, 2015). In recent years, there have been fruitful results of strengthening design teaching via digital platform in academic studies. However, teaching based on lacquer art design has continued to focus on traditional models, and studies focusing on the practice of strengthening lacquer design teaching via digital platform have not been performed.

### **RESEARCH METHODS**

#### **Action Research Method**

This study belonged to the category of teaching practice research. On one hand, both the researchers and the actors should jointly participate in the educational research activities with consistent process between the research and practical activity; on the other hand, the researchers should establish the value system from the perspective of the actors in practical educational environment, thus to facilitate the rationalization of educational practice (Wang, 2013). The most direct way for the researcher to get true feedback from students was to participate in the class as a front-line teacher. Obtaining students' real-time feedback via action research is an effective approach for teaching practice research. As mentioned by Zhang Wenshan, "action research is a method with significant emphasis on the combination of action and research with the aim of discussing the own decision-making model and practice process of the practitioner to get the solution" (Guan et al., 2007). The information obtained from the action research method features a broad range and high trueness, and it is conducive to promoting communication between teachers and students.





**Figure 1.** Diagram of traditional lacquer classroom teaching

### Comparative Research Method

There are many kinds of objectives for comparative education study, the two most common ones of which are explanation and causal analysis. The purpose of explanatory comparative research is to understand the education phenomenon; while some comparative researches attempt to analyze the causal correlation between two or more education phenomena (Bray, Adamson, & Mason, 2010). According to the viewpoints of Guo Chenjia regarding the comparative research method, “the word comparative indicates the mutual comparison between two or above items; thus, this research method shall be carried on the phenomenon with two or above kinds of different subjects to look for similarities and differences between them” (Guan et al., 2007). This study used the teaching of lacquer design theory as an entry point, and covered the history of lacquer culture development, lacquer design patterns and techniques, and lacquer art techniques, etc. The study was divided into two parts. In the first part, this study adopted traditional teaching methods by using personal examples as well as verbal instruction. In the second part, this study adopted teaching methods via a digital platform. A questionnaire survey was then given to the students in order to summarize the achievements and shortcomings of the two teaching methods and the degree of acceptance. The results could be used for continuous improvement and exploration in the future.

## RESEARCH AND ANALYSIS

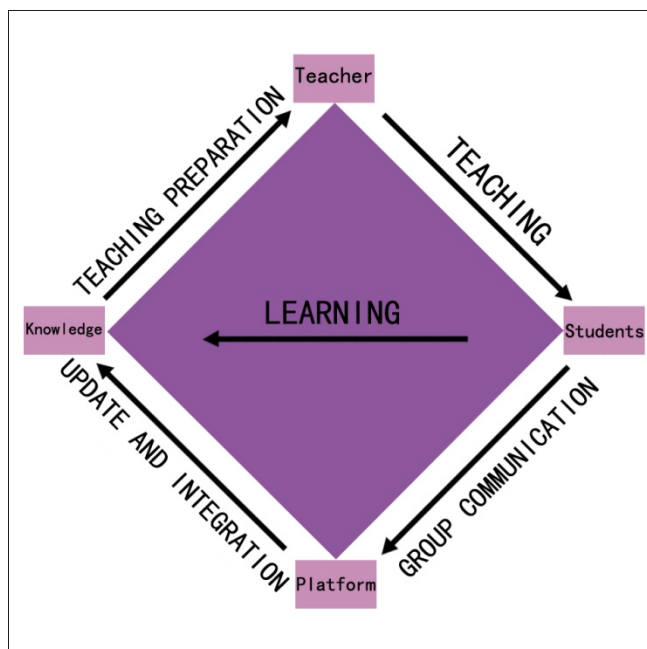
### Traditional Lacquer Classroom Teaching

It is rare that for Chinese lacquer courses to be held in middle and primary schools, and when they are, the teaching model focuses on the teacher’s oral teaching combined with writing on the blackboard and picture descriptions to deepen the students’ understanding. If possible, lacquerware is provided for teaching and outdoor teaching is carried out (Figure 1).

Such traditional lacquer teaching model have lower demand for a school’s teaching materials and mainly focus on paper teaching materials. Students only need to prepare pens and notebooks. In the class, students mainly listen to the teachers to acquire knowledge, and they have time to make notes and learn in a familiar teaching atmosphere. However, the learning environment is relatively isolated, and students have less enthusiasm to communicate with each other. Apart from break time questioning and after-class questionnaires, it is rare for teachers to obtain students’ feedback (Table 1).

**Table 1.** The traditional lacquer teaching procedures

Step	Time arrangement	Procedures
1	5 mins	Stabilize students' emotions and strengthen classroom discipline.
2	10 mins	Teacher explains the cultural development of lacquer art.
3	10 mins	According to the lesson materials, the teacher explains the material features of lacquer design as well as background knowledge.
4	20 mins	The teacher enables students to know the historical development of lacquer design modeling through hand drawing presentations on the blackboard.
5	20 mins	The picture presentation is combined to conclude several common lacquer techniques for students.
6	10 mins	The teacher gives a brief exposition of the lacquer development status in other parts of the world and introduces several extracurricular books related to lacquer design to the students, such as <i>Chinese lacquer and Design</i> (Zhu, China Architecture & Building Press, 2016) and <i>Lacquer Arts</i> (Zhu, Liaoning Fine Arts Publishing House, 2006).
7	5 mins	Time for answering questions.
8	10 mins	Combining the teaching materials on that day to comprehensively review the contents of the course.
9	10 mins	Asking the students to complete the questionnaire, and collect the results.



**Figure 2.** Diagram of teaching via a digital platform

### Application of Digital Platform Assisted Lacquer Design Teaching

There is a new procedure to apply digital platform to teach lacquer design theory. First, the school's network connection is necessary, WI-FI must be available, and digital equipment such as computers, projectors, and sound equipment must be provided to classrooms. As for the students, they need to have smart phones, tablets or computers, and they should register a personal WeChat account in advance, so that it is convenient for them to join in the online platform and share digital resources. In addition to the summary presentation of course content, teachers could display lacquer-related video data and HD photos via the digital platform, and achieve real-time sharing of relevant links. Students could immediately read the teaching materials and e-books recommended by the teacher. This teaching mode requires active interaction and cooperation from the students and changes the traditional identity of the teacher from that of a speaker to a sharer of learning resources at the same time. Students could spend their classroom time establishing a shared learning space, which is convenient for after-class communication and free learning via digital platform. Meanwhile, information from the digital platform also realizes updates and integration along with the increase of people following (Figure 2).

For middle and primary schools, adopting digital platform to strengthen lacquer design teaching is a new model, and it could be regarded as interdisciplinary teaching exploration. Rather than expect to figure out definite answers through classroom experiments, researchers hope to apply current technological platforms and effective

**Table 2.** Teaching procedures via digital platform

Step	Time arrangement	Procedures
1	5 mins	Stabilize students' emotions and strengthen classroom discipline.
2	15 mins	Explain the cultural development of lacquer art and combine with lacquer photos projection.
3	10 mins	Online display of teaching video "China Arts and Crafts: Exquisite Beyond Compare, Gold-inlaid Lacquer" ( <a href="http://tv.cntv.cn/video/C38459/4155b28b06a64df593c1afe81f918cf4">http://tv.cntv.cn/video/C38459/4155b28b06a64df593c1afe81f918cf4</a> )
4	10 mins	Online display of teaching video "China Arts and Crafts: Lacquer Art of Three Thousand Years" ( <a href="http://tv.cntv.cn/video/C38459/a4f13ebd8a94487d8e6b03460cd046b1">http://tv.cntv.cn/video/C38459/a4f13ebd8a94487d8e6b03460cd046b1</a> )
5	15 mins	Excerpt display of movie version of "Masters in Forbidden City" with aided interpretation from the teacher.
6	5 mins	Teacher establishes a real-time WeChat group for lacquer design resource sharing and invites the class to join.
7	5 mins	Real-time sharing of links and videos concerning the knowledge of lacquer design for students to check whether the group is functioning properly.
8	15 mins	Suggest students to download e-book apps and recommend several e-books relating to lacquer design, and encourage students to set up an e-book database for after-class free learning.
9	5 mins	Time for answering questions.
10	5 mins	Comprehensive review on the content of the class.
11	10 mins	Ask the students to complete the questionnaire and collect the results.

**Table 3.** Details of the four teams and groups participating in the experiments

Team's name	Number of students	Age of students	Classroom facility	Average accuracy
Team A	20	8-10	Traditional device	65%
Team B	20	8-10	Digital platform	74%
Team C	22	14-16	Traditional device	70.9%
Team D	22	14-16	Digital platform	83.6%

tools to teaching to provide students with more flexible and diversified approaches for obtaining knowledge (Vial, 2015). This study, under the action teaching model, conducted research on primary and middle schools respectively and emphasized transferring relevant information via a digital platform in addition to the course introduction and content overview (Table 2).

### Comparison of Teaching Experiment Results

In order to compare the traditional teaching method and the digital platform-assisted teaching model, the author conducted mobile teaching research for primary and middle school students by organizing two classes, according to the standards of the same school, number of students, foundation, class hours, age level and classroom facility. After the class, the same answer sheets were attached to be used as the measuring standard. In the end, the accuracy of the answers was counted to compare the teaching effects of the two methods via the objective data (Table 3).

The teaching steps of the two models are described in the previous paragraphs and the basic information about teaching objects is displayed out in the above-mentioned tables. Regarding the front-line teaching personnel, the author summarized the following research results through classroom observation (Table 4).

**Table 4.** Contrast of teaching research results

Content	Traditional lacquer classroom teaching	Digital platform-assisted lacquer teaching
Student's degree of attention	Traditional lacquer classroom teaching focuses on the instructor's oral teaching, in which the classroom atmosphere is relatively silent and students keep their minds on the teacher and illustrated teaching materials.	In digital platform-assisted lacquer teaching, with the guidance of teachers, mobile phones and other equipment are applied, and it adopts data retrieval and sharing learning as the main form of instruction. Students can pay high attention to digital platform and they sometimes communicate with each other in a low voice.
Learning initiative	In traditional lacquer classroom teaching, the teacher will ask students questions about the certain course contents during break time to test the students' learning effect. In that case, students will not actively raise their hands and the teacher must call their names to answer the questions. The after-class questioning link is relatively not active.	In digital platform-assisted lacquer teaching, students will actively ask questions about network information, but the questions raised are sometimes beyond the teaching scope. Lastly, the theme of questioning links mainly centers on communication via after-class online platforms.
Learning effect	The accuracy of after-class questionnaires in traditional lacquer classroom teaching is lower.	The accuracy of after-class questionnaires in digital platform assisted lacquer teaching is higher.

According to the research results, the application of digital platform-assisted lacquer teaching in middle and primary school can make the classroom atmosphere active and improve the learning effect. Thanks to the enthusiasm for science and technology, students can easily throw themselves into interactive learning through digital platform. Teachers not only need to encourage students to communicate with each other, but also keep to the discussion subject in the class, so as to avoid deviating from the main course contents due to the expansion of students' thinking.

### Blueprint Prospect for Future Teaching

According to the study results, aiding lacquer design teaching via digital platform is an excellent model with positive significance. For primary and secondary school students, learning by video could acquaint them with lacquer-concerned basic knowledge through explaining the profound in simple terms, and by reading e-books when possible to provide good learning conditions for theoretical knowledge accumulation.

Along with the increasing development of technology, more abundant teaching approaches will be available in the future in virtue of digital platform, and teachers will perform as the designers for technology intensifying and learning (McKenney, Kali, Markauskaite, & Voogt, 2015). Two perspectives were proposed by the author. First is to carry out research and development of apps and games around the themes of lacquer art and learning through entertainment, which are especially suitable for primary school students as games feature a strong visual impact and could give an effective presentation of the Totem ornamentation and color characteristics of lacquer design elements via intuitive visual images. Second is to arrange lacquer art design teaching in class. After all, regardless of whether instruction is based on the teacher's verbal instruction, slide shows of photos, or watching videos of real lacquer design works, it only engages in idle theorizing. Regular courses in middle and primary schools are rarely given together with outdoor teaching and are difficult for students to obtain the feeling of the history of traditional lacquer culture. The development of VR (virtual reality) technology in recent years could solve this problem effectively. Just as VR technology has been adopted as a guidance tool by major provincial museums in China, the action of turning the lacquer art culture of previous dynasties into VR teaching videos to introduce knowledge could create a magnificent lacquer art culture experience for students during tours of cultural relics and historic sites.

### Discussion

Lacquer design mainly focuses on the theory teaching in primary and secondary school classes in China and lays stress on the improvement of students' comprehensive aesthetic quality, rather than the capacity in lacquer art works creation. Under the circumstance of smooth network and complete equipment, the application of digital platform in aiding teaching could enhance the efficiency of learning, and so as to achieve the aim of enabling more students to have access to the historical and cultural knowledge of lacquer art.

Compared with the quality-oriented education at the theoretical level in middle and primary school, lacquer design in university mostly takes creative courses as the main line, involving practical operation and practice, emphasizing lacquer's handicraft value, and underlining the touching feeling in hand. University students' sensitivity to lacquer materials does not merely rely on the eyes to feel across the computer screen; hand sensory ability and the ability to control materials are particularly important.

In practice-oriented creation classes, digital platform also plays a crucial part in effective assistance for students in theoretical knowledge acquisition, creation materials collection, on-line study and discussion, and thus to stimulate inspiration and broaden the vision. The high-efficient learning model based on the digital platform enables students to have more sufficient time and efforts to complete their own works, improve their own control ability on lacquer materials and further enhance the practical skills. Therefore, the application of digital platform-assisted lacquer design teaching in university is still useful for students' online communication and knowledge improvement; however, it is necessary to place emphasis on practical skill teaching.

## CONCLUSION

According to this teaching experiment, combined with the statistical data of the students' after-class questionnaire, it was clear that the application of lacquer design teaching via a digital platform features obvious advantages that enabled the students to perform free study, collect rich knowledge relating to lacquer art design in a short time, realize resource sharing and real-time updating, and even debate and discuss questions with their teachers. Learning via digital technology is a new global trend and presents a complete teaching model (Sorensen & Murchu, 2006). As a kind of tool, digital platform could be used to bring changes to teaching models and learning styles.

For lacquer design teaching in the earlier grades, it is a part of assistant teaching for aesthetical quality improvement with a large amount of knowledge, but short teaching hours available from school. Teachers, as the course designers, could make the original class become vivid and increase the chances of after-class communication if they teach via a digital platform with diversified teaching methods and extensive connections with teenage life styles. This could play an active role in terms of strengthening the courses' teaching results.

## ACKNOWLEDGEMENTS

We would like to express our gratitude to Taiwan Ministry of Science and Technology for providing research resources on this study. (No. 106-2410-H-224-018).

## REFERENCES

- Bernal, M., & Eastman, C. (2015). On the role of computational support for designers in action. *Design Studies*, 41, 163-182. <http://dx.doi.org/10.1016/j.destud.2015.08.001>
- Bray, M., Adamson, B., & Mason, M. (2010). *Comparative Education Research: Approaches and Methods*, pp. 72-73. Beijing: Peking University Press.
- Guan, X. S. et al. (2007). *Design Research Methods*, pp. 279-299. Taipei: Chuan-Hwa Book Co. LTD.
- Jiang, K. Y. (2013). New Thought on Design Teaching. *Course Education Research*, 2, 199. <http://www.airitilibrary.com/Publication/alDetailedMesh?DocID=kcjyyj-xjsjx201302187>
- Kirschner, P. A. (2015). Do we need teacher as designers of technology enhanced learning? *Instructional Science*, 43, 309-322. <https://doi.org/10.1007/s11251-015-9346-9>
- Mckenney, S., Kali, Y., Markauskaite, L., & Voogt, J. (2015). Teacher design knowledge for technology enhanced learning: an ecological framework for investigating assets and needs. *Instructional Science*, 43, 181-202. <https://doi.org/10.1007/s11251-014-9337-2>
- Milrad, M., Wong, L.-H., Sharples, M., Hwang, G.-J., Looi, C.-K., & Ogata, H. (2013). Seamless learning: an international perspective on next-generation technology-enhanced learning. In: (Berge, Zane L. & Muilenburg, Lin Y. Eds.), *Handbook of Mobile Learning*. Abingdon: Routledge, pp. 95-108.
- National Bureau of Statistics of China. (2017). "Statistical Communiqué of the People's Republic of China on the 2016 National Economic and Social Development". Retrieved from: [http://www.stats.gov.cn/tjsj/zxfb/201702/t20170228\\_1467424.html](http://www.stats.gov.cn/tjsj/zxfb/201702/t20170228_1467424.html)
- Salman, H. S., Laing, R., & Conniff, A. (2014). The impact of computer aided architectural design programs on conceptual design in an educational context. *Design Studies*, 35, 412-439. <http://dx.doi.org/10.1016/j.destud.2014.02.002>
- Sorensen, E. K., & Murchu, D. O. (2006). *Enhancing Learning through Technology*, pp.vi. Hershey: Information Science Publishing.
- Vial, S. (2015). Philosophy applied to design: A design research teaching method. *Design Studies*, 37, 59-66. <http://dx.doi.org/10.1016/j.destud.2014.12.006>

Wang, P. F. (2013). *Theory and Methodologies of Action Research* (pp. 71). Beijing: Capital Normal University Press.

Zhu, L. Y. (2014). The Simple Discussion of the New Thinking Mode in Art Design Specialized Teaching. *Oriental Education*, 8, 293-294. <https://doi.org/10.3969/j.issn.2079-3111.2014.08.284>

## APPENDICES

### Appendix 1. After-Class Questionnaire of the Course

No.	Questionnaire contents and options	Answer
Question 1	How long is the history of [Vermilion Lacquer Wooden Bowl], the earliest lacquerware discovered in Chinese archaeology? A. 8000 years; B. 7000 years; C. 6000 years; D. 5000 years	B
Question 2	The classic color assortment for China's early lacquer art during Qin and Han dynasty is [ ]. A. Yellow and green; B. Purple and blue; C. Black and red; D. Red and yellow	C
Question 3	The wine container used in the ancient game [drinking wine from a floating cup to wash away ominousness], is called as [ ]. A. Eared lacquer cup; B. round plate lacquerware with stems; C. lacquer casket; D Lacquer wooden spoon	A
Question 4	Which dynasty did China's [single color lacquer coating] originate from? A. Tang Dynasty; B. Song Dynasty; C. Yuan Dynasty; D. Ming Dynasty	B
Question 5	As lacquer art was in prosperous period during Yuan Dynasty, the technique of [ ] reached the peak of perfection. A. Gold inlay; B. Bodiless lacquerware;; C. Carved lacquerware; D. Namiki	C
Question 6	[ ] made by Huang Cheng of Ming Dynasty is the only existing ancient lacquering works in China. A. The Artificers Record; B. Xuanhe Painting Book; C. Exploitation of the Works of Nature; D. Records of Lacquering	D
Question 7	After moving the capital to Beijing in Ming Dynasty, [ ] was set in the imperial city to manage the production of lacquerware. A. The Operatic Circle; B. National Academy; C. Office of works; D. Guoyuanchang	D
Question 8	In the later period of [ ], the government opened the maritime trade, private maritime trade gained growth and the lacquer art quickly spread to Europe. A. Tang Dynasty; B. Song Dynasty; C. Yuan Dynasty; D. Ming Dynasty	D
Question 9	[ ] bodiless lacquerware, Beijing cloisonné and chinaware of Jingde town, are jointly named as [Three unique greats of traditional Chinese arts and crafts]. A. Fujian; B. Shanxi; C. Jiangsu; D. Guangdong	A
Question 10	In today's Asian area, which of the following country does not belong to the great lacquer art countries? A. Korea; B. Indonesia; C. China; D. Vietnam	B



### Appendix 2. The Accuracy of the Questionnaire

Team A	Accuracy	Team B	Accuracy	Team C	Accuracy	Team D	Accuracy
Student 1	70%	Student 1	80%	Student 1	80%	Student 1	90%
Student 2	70%	Student 2	70%	Student 2	60%	Student 2	80%
Student 3	60%	Student 3	70%	Student 3	60%	Student 3	90%
Student 4	60%	Student 4	80%	Student 4	70%	Student 4	90%
Student 5	50%	Student 5	80%	Student 5	80%	Student 5	70%
Student 6	60%	Student 6	80%	Student 6	80%	Student 6	80%
Student 7	80%	Student 7	60%	Student 7	70%	Student 7	80%
Student 8	50%	Student 8	70%	Student 8	60%	Student 8	80%
Student 9	80%	Student 9	70%	Student 9	80%	Student 9	80%
Student 10	60%	Student 10	70%	Student 10	70%	Student 10	60%
Student 11	60%	Student 11	90%	Student 11	80%	Student 11	80%
Student 12	60%	Student 12	80%	Student 12	70%	Student 12	90%
Student 13	70%	Student 13	70%	Student 13	70%	Student 13	80%
Student 14	80%	Student 14	80%	Student 14	70%	Student 14	80%
Student 15	70%	Student 15	80%	Student 15	60%	Student 15	100%
Student 16	70%	Student 16	50%	Student 16	80%	Student 16	90%
Student 17	60%	Student 17	60%	Student 17	80%	Student 17	100%
Student 18	60%	Student 18	80%	Student 18	70%	Student 18	100%
Student 19	80%	Student 19	90%	Student 19	70%	Student 19	80%
Student 20	50%	Student 20	70%	Student 20	70%	Student 20	70%
				Student 21	70%	Student 21	70%
				Student 22	60%	Student 22	100%

<http://www.ejmste.com>



<http://www.ejmste.com>



<https://twitter.com/ejmste>



<https://www.facebook.com/ejmste>



<http://modestum.co.uk/>



[publications@modestum.co.uk](mailto:publications@modestum.co.uk)

# Effects of Digital Flipped Classroom Teaching Method Integrated Cooperative Learning Model on Learning Motivation and Outcome

Jian Qiang <sup>1\*</sup>

<sup>1</sup> School of Marxism Studies Central Plains Rural Development Research Center, Xuchang University, CHINA

Received 17 November 2017 • Revised 8 January 2018 • Accepted 1 March 2018

## ABSTRACT

Along with the time change and promotion of 12-year compulsory education, traditional didactic instruction can no longer satisfy all students. The reform wave in education is therefore emerged in past years, where the “flipped classroom” model strikes a chord and becomes a trend. Applying nonequivalent pretest posttest control group design to the experimental research, 242 students of Xuchang University in Henan Province are proceeded the 2×2 experiment integrating flipped classroom teaching method with cooperative learning for 15 weeks, 3hrs per week. The research results show significant effects of 1. flipped classroom teaching method on learning motivation, 2. flipped classroom teaching method on learning outcome, 3. cooperative learning on learning motivation, 4. cooperative learning on learning outcome, 5. flipped classroom teaching method integrated cooperative learning on the promotion of learning motivation, and 6. flipped classroom teaching method integrated cooperative learning on the promotion of learning outcome. Finally, suggestions are proposed according to the results, expecting to assist domestic education in promoting students’ learning motivation and outcome as well as teaching methods.

**Keywords:** flipped classroom teaching method, cooperative learning, learning motivation, learning outcome

## INTRODUCTION

In the past decade, new innovation and improvement emerged in the field of information technology. The emergence of network, cheaper storage space, advanced computer efficacy, new equipment, e.g. smart phones and tablet PC, and the breakthrough of other mobile devices explained the provision of new digital experience for students and led the new generation to change the daily life and learning habits. Students in the millennial depend more on information technology and reduce the tolerance of didactic teaching styles. In other words, students appear distinct needs and expectation on education systems that the way of thinking should be changed. In such a situation, above technological tools allow people thinking about education from the beginning and change the past habitual and inherent ideas. Such a thought needs to be changed from traditional teachers’ teaching and learning to students’ active learning and help students more actively participate in learning. Individualized instruction is required for students’ adaptive learning in modern education. Nonetheless, teachers could hardly satisfy each student’s needs in school education, due to teaching time and schedule. Generally, a teacher could merely teach students with the average standards. Some low-achievement students present low learning motivation and appear helplessness to become “guests” in the class. On the other hand, those with excellent academic performance might be familiar with most contents in textbooks to become “systematically demotivated” as they consider the lessons in classes being too easy.

As a result, differentiated instruction should be practiced in classes in order to achieve each child. In this case, teachers, when designing lessons, should change the traditional didactic instruction model according to the characteristics of subjects and students’ characters and differences, induce students’ active learning, and cultivate the transferable skills and applicable knowledge. In comparison with other learning methods, flipped classroom teaching method is student-centered and can better induce students applying the learned knowledge to high-level

#### **Contribution of this paper to the literature**

- Teachers could guide students, in classes, how to learn by viewing films to cultivate students' reading, thinking, and comprehension abilities step by step, and then increase the length of films.
- Teachers could make suitable teaching films for low-, medium-, and high-level students. Different films emphasize suitable points for students so that each student could understand the lesson contents before classes and reduce the learning load in classes.
- For long-term team cooperative learning, the team members could be regularly changed so that students have more interaction and learning opportunities.

thinking. The application of flipped classroom teaching method could help students understand the learning conditions, create student-centered learning environments, and provide opportunities for students cultivating learning motivation. Accordingly, the effect of digital flipped classroom teaching method integrated cooperative learning model on learning motivation and outcome is discussed in this study in order to achieve the outcome of flipped classroom instruction and allow students being more successful.

## LITERATURE AND HYPOTHESIS

### **Flipped Classroom Teaching Method**

Baytiyeh (2017) described flipped classroom as a relatively new education model, mainly focused on student-centered instruction. Things done in traditional classes, e.g. didactic instruction, were transferred to homework, and traditional homework and program activity were transferred into class activity. In this case, students had to view teaching films at home and do homework in classes, with the assistance of classmates and the guidance of teachers (Kim et al., 2015). Chen, Wang, Kinshuk, and Chen (2014) advocated four major points of flipped classroom that FLIP was the flexible environment, could benefit the creation of meaningful learning culture, could achieve intentional content, and require professional educators' growth. Flipped classroom was initiated by two senior high school teachers in 2007. Both of them recorded the class contents and explained that absent students could catch up with other classmates. Video software and PowerPoint were used for recording lessons, allowing students downloading through YouTube. Later on, they observed surprising changes in the class activity that both absent students and others would learn with recorded films (Moran & Milsom, 2015). The process helped them comprehend and guide students' learning and assignments as well as changed the role of teacher. Now, they do not simply concentrate on lecturing, but start to observe students in groups and make sure of the students who required more explanations and guidance (Dass, Head, & Rushton, 2015). Being a learning model, flipped classroom induced a lot of concerns of Salman Khan, who promoted the idea through TED speeches (Sletten, 2017) and provided more teaching films of subjects. Under fixed curricula, students were taught to view lesson films at home and do homework in schools (Flynn, 2015). Subject teaching films now have become the major resource for teachers practicing flipped classroom; teachers do not need to make teaching films, but make plans to practice flipped classroom with the assistance of such films (Rui et al., 2017). Resources similar to flipped classroom teaching method in domestic education platforms freely provide "equal and excellent" education opportunities (lessons) for each person through cloud platform (Hsu et al., 2016). Flipped classroom releases the time in classrooms and present potential and extraordinary learning methods to enhance students' application of learned knowledge and high-level thinking. Wanner and Palmer (2015) indicated that teachers, in the learning activity, enhanced students applying learned knowledge through practice, making plans, discussion, and problem solving and students could control the learning steps and be responsible for the learning processes.

### **Cooperative Learning**

Choi, Hand, and Norton-Meier (2014) mentioned that cooperative learning boomed since 1970; cooperative learning referred to more than two people achieving the common learning goals through mutual interaction and assistance as well as responsible sharing. The cooperation aimed to develop the effect of 1+1>2. The basic concept of "team cooperative learning" was that students were willing to see the team successfully achieving the learning goals, would encourage other classmates to pursue excellent performance, and even assist other classmates in the realization. Cooperative learning was a kind of group learning to enhance the learning outcome of individuals and other members in the team (Kong, 2015). In the cooperative learning environment, the teaching model appeared major changes from "teacher centered" to "student centered"; teachers were learning guides, while students were active learners (Huang & Hong, 2016). In this case, cooperative learning was a structured and systematic teaching strategy to precede learning with heterogeneous grouping, team discussion and interaction, and peer assistance and to cultivate students more cooperation skills to achieve common learning goals. Cooperative learning was not

a single teaching strategy, but all teaching strategies for enhancing team cooperation and student interaction (Baepler, Walker, & Driessen, 2014). In comparison with competitive learning or individual learning, it could better promote students' learning motivation, learning outcome, and cooperation skills and was a teaching strategy worth of application to instruction (Sarantos, 2016). Nichols, Gillies, and Hedberg (2016) pointed out cooperative learning as the teaching method to enhance individual and team members' learning with team grouping, but not to have students chat together but do individual assignments, not to independently complete assignments but have others sign the names, nor to complete assignments individually and then help slower ones. Demirbag and Gunel (2014) regarded cooperative learning as a structured and systematic teaching strategy; in cooperative learning, teachers allocated 4-6 students with different capabilities in a heterogeneous team to learn together, share experiences in the same team, and accept affirmation and rewards. Accordingly, cooperative learning was the learner-centered learning process; each member in the team was responsible for the performance (Porcaro, Jackson, McLaughlin, & O'Malley, 2016). Regarding the learning environment, a teacher had to face many students and could not take care of individual development. Cooperative learning therefore had team members cooperate with each and mutually support for learning as well as created team contests to enhance learning motivation (Wang, Guo, & Jou, 2015). Gilboy, Heinerichs, and Pazzaglia (2015) emphasized that cooperative learning allowed students working together to achieve common goals which were beneficial to oneself as well as others.

### Learning Motivation

Lin et al. (2017) regarded motivation as the essential condition for individuals proceeding long-term effective and meaningful learning. Learning motivation was a kind of motivation. Clark (2015) pointed out motivation to learn as the psychological process to induce students' learning, maintain learning, and have the learning activity approach to the goal set by teachers. González-Gómez, Jeong, Airado Rodríguez, and Cañada-Cañada (2016) regarded learning motivation as the inner belief in leading individual learning goals, inducing learning behavior and continuous efforts, reinforcing cognition process, and enhancing and improving learning results. Demircioglu and Ucar (2015) proposed that learning motivation was the psychological factor in encouraging students' learning activity. It was an internal drive directly promoting students' learning as well as the initiation and awakening of learning behavior. According to the value-expectation model proposed by Hwang and Tsai (2015), it is considered in this study that ability belief, expectation of success, and work value are the key factors of learning motivation in students' self-adjustment learning process. Ability belief refers to students' perceived personal capability when engaging in learning. Expectation of success refers to students' expectation of personal success in the learning. Such expectation is efficacy expectation, not outcome expectancies, i.e. learners' perceived learning performance and selection, rather than expected results. Learning motivation is a mediator between stimuli and responses. That is, learning motivation is a learner's personal opinions, and learners would appear distinct knowledge needs because of different opinions. According to the research of Chen, Hand, and Park (2016), students' learning motivation is measured with single dimensions in this study, including in favor of challenging lessons and regarding learning as interests, hobby, others' affirmation, acquisition of better performance, passing examinations or evaluation, showing off to others, competing with classmates, acquiring appreciation and notice from the elderly or the opposite gender, not being punished and blamed, not having the shame of failure, and getting into ideal schools in the future.

### Learning Outcome

Learning outcome is generally regarded as various evaluations of learners' completion of certain learning activity and the achievement of learning activity to the expected effect (Fakari et al., 2015), i.e. the changes of learners' knowledge, skills and behaviors, and attitudes after the end of instruction (Novak, Kensington-Miller, & Evans, 2017). Chen et al. (2016) indicated that learning outcome, an indicator to evaluate students' learning outcome and teaching quality, would be affected by curriculum design, teaching methods, and learning behaviors. Students' learning aimed to monitor self-learning, reflect learned knowledge, and learn to learn that learning outcome was the most direct presentation of learning results. Students' learning results was one of major indicators to measure learning outcome as well as the main item to evaluate teaching quality (Joanne & Lateef, 2014). For this reason, outcome also aimed to test the achievement of learning or teaching goals and could be revised for the reference of next curriculum improvement. Makransky et al. (2016) regarded it as students' affirmation of personal learning ability in the teachers' teaching processes. Learning outcome was the guidance to measure instructors' results and teaching quality as well as the indicator of learners' learning results. Cohen (2016) pointed it out as the indicator to evaluate students' learning results and the major item to evaluate teaching quality. Learning outcome would be affected by curriculum design, teaching methods, and learning behaviors. Students' learning aimed to monitor self-learning, reflect learned knowledge, and learn to learn that learning outcome was the most direct presentation of learning results. According to Hsu et al. (2015), learning outcome is measured with single dimensions in this study, covering test performance, time for schedule completion, and term scores.

## Research Hypothesis

Chen et al. (2015) flipped 53 students majoring in statistics, largely reduced the time for lecturing, and increased the proportion of interaction in classes. Online reading test was preceded before each class to encourage students completing reading assignment as well as encourage students searching network resources to respond to the questions on reading. Traditional lecturing is reduced to the least, and knowledge delivery occurred outside classrooms to successfully enhance students' learning motivation and outcomes. Baytiyeh (2017) indicated that students, in flipped classrooms, had to complete knowledge learning before the class and proceed cooperative learning with teachers and classmates in schools (Sletten, 2017) that a class became the place for the interaction between teachers and students and among students. Lin et al. (2017) mentioned that students could enhance the learning interests by the mutual teaching among students in classes to enhance the absorption and internalization of knowledge, i.e. enhancing students' learning interests through cooperation among students. The following hypothesis is therefore proposed in this study.

**H1:** Flipped classroom teaching method presents significant effects on learning motivation.

Chen et al. (2014) flipped the problem-solving activity of didactic instruction (e.g. team practice and computer simulation) and enhanced several interactive activities (e.g. responding to tests with the real-time response system of Clicker). Both two positive lessons combined flipped and mixed learning (Clark, 2015). Two flipped/mixed lessons had students' learning performance exceed the performance with traditional didactic methods. Besides, students with flipped lessons presented higher satisfaction in the learning process. González-Gómez et al. (2016) discovered that most students presented skills required for lessons and showed affirmation to flipped learning; peer learning and structured learning activity obviously enhanced the test of learning outcome. Hwang and Tsai (2015) provided specific methods for readers' reference through flipped classroom and understood that flipped classroom could reduce the time for teachers interpreting knowledge to increase more time for explaining students' learning problems. It would enhance teaching efficacy as well as promote students' learning outcome. Accordingly, the following hypothesis is proposed in this study.

**H2:** Flipped classroom teaching method shows remarkable effects on learning outcome.

Chen et al. (2016) indicated that the popularity of tablet devices in higher education allowed instruction tending to students previewing at home. In this case, students could achieve better learning effects with the learning speed and the class time could be saved for further dialogues and interaction. Such a dialogue and interaction method was a kind of cooperative learning. Nichols et al. (2016) indicated that, under many research results and analyses of cooperative learning, the application to math teaching could enhance students' learning achievement and interests, and students could more actively learn and face problems as well as enhance the learning motivation of math. Regardless the cooperative learning with teachers or peers, it could be observed in education sites that students were gradually interested in learning (Huang & Hong, 2016). As a result, a lot of teachers started to flip the classroom, especially cooperative learning, to enhance students' learning motivation and not to escape from learning (Gilboy et al., 2015). The following research hypothesis is further proposed in this study.

**H3:** Cooperative learning reveals notable effects on learning motivation.

Makransky et al. (2016) stated that students were emphasized as the learning body in the cooperative learning process to collect data, study problems, and further solve problems according to students' problems. It was the idea to stress on active learning (Demirbag & Gunel, 2014), where students had opportunities to enhance learning effects with learned knowledge and skills through discussion with classmates in the same teams, manual operation, or teaching others in the class. Cohen (2016) pointed out the content of cooperative learning as students organizing and analyzing problems through classmate discussion. Hsu et al. (2015) explained cooperative learning as teachers indirectly helping and guiding students and inducing peers' active participation and interaction. Students' intrinsic learning motivation could be induced in interpersonal interaction. Mutually encouragement among peers in classrooms was the largest push of learning motivation to enhance learning outcome. Accordingly, the following hypotheses are proposed in this study.

**H4:** Cooperative learning appears significant effects on learning outcome.

**H5:** Flipped classroom teaching method integrated cooperative learning presents remarkable effects on the promotion of learning motivation.

**H6:** Flipped classroom teaching method integrated cooperative learning shows notable effects on the promotion of learning outcome.



**Table 1.** Difference analysis of flipped classroom teaching method

Variable		F	P	Scheffe post hoc
Flipped Classroom	Learning Motivation	9.632	0.000**	flipped classroom teaching method>traditional didactic instruction
Teaching Method	Learning Outcome	10.153	0.000**	flipped classroom teaching method>traditional didactic instruction

\* stands for  $p < 0.05$ , \*\* for  $p < 0.01$

**Table 2.** Difference analysis of flipped classroom teaching method

Variable		F	P	Scheffe post hoc
Cooperative Learning	Learning Motivation	8.768	0.000**	cooperative learning>traditional didactic instruction
	Learning Outcome	9.526	0.000**	cooperative learning>traditional didactic instruction

\* stands for  $p < 0.05$ , \*\* for  $p < 0.01$

## RESEARCH METHOD

### Research Object and Research Design

To effectively achieve the research objective and test research hypotheses, nonequivalent pretest posttest control group design is utilized for the experimental research in this study. Total 242 students of Xuchang University in Henan Province, as the research object, are proceeded flipped classroom teaching method integrated cooperative learning<sup>2/2</sup> experiment. The experiment is grouped cooperative learning (cooperative learning, traditional didactic instruction) \flipped classroom teaching method (flipped classroom teaching method, traditional didactic instruction) for the 15-week (3hrs per week) experimental instruction.

### Analysis Method

Analysis of Variance is applied in this study to discuss the effects of flipped classroom teaching method and cooperative learning on learning motivation and learning outcome and further understand the effects of flipped classroom teaching method integrated cooperative learning on learning motivation and learning outcome.

## RESULT AND ANALYSIS

### Difference Analysis of Flipped Classroom Teaching Method in Learning Motivation and Learning Outcome

According to Analysis of Variance, the difference of flipped classroom teaching method in learning motivation and learning outcome is discussed. Flipped classroom teaching method appears significant differences from traditional didactic instruction in learning motivation and learning outcome which are higher with flipped classroom teaching method than with traditional didactic instruction that H1 and H2 are supported.

### Difference Analysis of Cooperative Learning in Learning Motivation and Learning Outcome

According to Analysis of Variance, the difference of cooperative learning in learning motivation and learning outcome is discussed. From **Table 2**, cooperative learning shows remarkable difference from traditional didactic instruction in learning motivation and learning outcome, which are higher with cooperative learning than with traditional didactic instruction that H3 and H4 are supported.

### Effect Analysis of Flipped Classroom Teaching Method Integrated Cooperative Learning

According to Analysis of Variance, the difference of flipped classroom teaching method integrated cooperative learning in learning motivation and learning outcome is discussion. With Two-way Analysis of Variance, the interaction of flipped classroom teaching method and cooperative learning is used for testing the promotion of learning motivation and learning outcome. From **Table 3**, both learning motivation and learning outcome appear the highest on flipped classroom teaching method integrated cooperative learning that H5 and H6 are supported.

**Table 3.** Difference analysis of flipped classroom teaching method integrated cooperative learning in learning motivation and learning outcome

Variable	Learning motivation			Learning outcome		
	F	P	Scheffe post hoc	F	P	Scheffe post hoc
Flipped Classroom Teaching Method	9.632	0.000**	flipped classroom teaching method>traditional didactic instruction	10.153	0.000**	flipped classroom teaching method>traditional didactic instruction
Cooperative Learning	8.768	0.000**	cooperative learning>traditional didactic instruction	9.526	0.000**	cooperative learning>traditional didactic instruction
Flipped classroom teaching method*Cooperative learning	16.733	0.000**	11>21>12>22	19.275	0.000**	11>21>12>22

\* stands for  $p < 0.05$ , \*\* for  $p < 0.01$ 

## CONCLUSION

This experimental research discusses the effect of flipped classroom teaching method integrated cooperative learning on students' learning motivation and learning outcome. The results reveal that, in comparison with traditional didactic instruction, almost all students are in favor of flipped classroom instruction and completing homework in class activity. Students would actively ask questions when encountering difficulties in classes and express personal opinions in the interaction process; classmates with better capabilities would actively help lower-level classmates so that almost all students participate in the class activity. Flipped classroom teaching method allows students preview lessons before classes to reduce students' pressure of direct lessons in traditional learning. The class activity enhance students' reading, thinking, and comprehension opportunities, teachers merely need to timely provide guidance to reduce the load, and students enhance the learning motivation and efficiency in the practical learning. Flipped classroom could cultivate children' attitudes towards autonomous learning, induce children's learning motivation, and allow teachers' individualized instruction to further enhance learning outcome. Teachers are the success key in flipped classroom. When teachers are willing to make changes, the new appearance of education would be seen. Nevertheless, flipped classroom might spend more time than traditional didactic instruction that teachers' curriculum design and preparation are important. Detailed lesson plans before classes allow smooth lessons and easy achievement of teaching goals. Cooperative learning could have instruction become diversified, and students could enhance the lesson participation and learning interests to promote learning outcome through peers and teacher-student interaction. The key success factors in cooperative learning include teachers' teaching preparation and activity design, mutual dependency among team members, and skilled interpersonal interaction skills. For this reason, teachers have to stress on class management and students' good interaction and harmonious atmosphere in class to assist in proceeding cooperative learning.

## SUGGESTION

According to research conclusions, the following suggestions are proposed in this study.

1. It has been the difficulty in the practice of flipped classroom teaching method to confirm that students really seriously view teaching films before classes. Even though such students really view teaching films, they would not necessarily learn the points. It is therefore suggested that the practice of flipped classroom teaching method is the earlier the best. Teaching films with shorter time could be selected in this beginning; meanwhile, teachers could guide students, in classes, how to learn by viewing films to cultivate students' reading, thinking, and comprehension abilities step by step, and then increase the length of films.
2. Teachers could make suitable teaching films for low-, medium-, and high-level students. Different films emphasize suitable points for students so that each student could understand the lesson contents before classes and reduce the learning load in classes. Even though the teaching films are existing ones on the Internet, the films could be post-produced for different-level students paying attention to the learning points. It is expected to reduce the drawbacks of traditional flipped classroom instruction, but merely few high-level students would learn with teaching films before classes.
3. For long-term team cooperative learning, the team members could be regularly changed so that students have more interaction and learning opportunities. When guiding discussions, teachers could participate in team discussion when necessary to thoroughly understand students' learning conditions and have high-

level students lead low-level students' learning. It could assist in the practice of flipped classroom teaching method integrated cooperative learning.

## REFERENCES

- Baepler, P., Walker, J. D., & Driessen, M. (2014). It's not about seat time: Blending, flipping, and efficiency in active learning classrooms. *Computers & Education*, 78(0), 227-236. <https://doi.org/10.1016/j.compedu.2014.06.006>
- Baytiyeh, H. (2017). The flipped classroom model: When technology enhances professional skills. *International Journal of Information and Learning Technology*, 34(1), 51-62. <https://doi.org/10.1108/IJILT-07-2016-0025>
- Chen, S.-C., Yang, S. J. H., & Hsiao, C.-C. (2015). Exploring student perceptions, learning outcome and gender differences in a flipped mathematics course. *British Journal of Educational Technology*, 47(6), 1096-1112. <https://doi.org/10.1111/bjet.12278>
- Chen, Y., Wang, Y., Kinshuk, & Chen, N.-S. (2014). Is FLIP enough? Or should we use the FLIPPED model instead? *Computers & Education*, 79(0), 16-27. <https://doi.org/10.1016/j.compedu.2014.07.004>
- Chen, Y.-C., Hand, B., & Park, S. (2016). Examining elementary students' development of oral and written argumentation practices through argument-based inquiry. *Science & Education*, 25(3), 277-320. <https://doi.org/10.1007/s11191-016-9811-0>
- Choi, A., Hand, B., & Norton-Meier, L. (2014). Grade 5 students' online argumentation about their in-class inquiry investigations. *Research in Science Education*, 44(2), 267-287. <https://doi.org/10.1007/s11165-013-9384-8>
- Clark, K. R. (2015). The effects of the flipped model of instruction on student engagement and performance in the secondary mathematics classroom. *Journal of Educators Online*, 12(1), 91-115. <https://doi.org/10.9743/JEO.2015.1.5>
- Cohen, M. E. (2016). The flipped classroom as a tool for engaging discipline faculty in collaboration: A case study in library-business collaboration. *New Review of Academic Librarianship*, 22(1), 5-23. <https://doi.org/10.1080/13614533.2015.1073162>
- Dass, K., Head, M. L., & Rushton, G. T. (2015). Building an understanding of how model-based inquiry is implemented in the high school chemistry classroom. *Journal of Chemical Education*, 92(8), 1306-1314. <https://doi.org/10.1021/acs.jchemed.5b00191>
- Demirbag, M., & Gunel, M. (2014). Integrating argument-based science inquiry with modal representations: Impact on science achievement, argumentation, and writing skills. *Educational Sciences: Theory and Practice*, 14(1), 386-391. <https://doi.org/10.12738/estp.2014.1.1632>
- Demircioglu, T., & Ucar, S. (2015). Investigating the effect of argument-driven inquiry in laboratory instruction. *Educational Sciences: Theory and Practice*, 15(1), 267-283. <https://doi.org/10.12738/estp.2015.1.2324>
- Fakari, F. R., Kordi, M., Mazloom, S. R., Khadivzadeh, T., Tara, M., & Akhlaghi, F. (2015). Comparing the effect of traditional, web based and simulation training on midwifery students' clinical competence in postpartum hemorrhage management. *Journal of Mazandaran University of Medical Sciences*, 25(123), 67-79.
- Flynn, A. B. (2015). Structure and evaluation of flipped chemistry courses: Organic & spectroscopy, large and small, first to third year, English and French. *Chemistry Education Research and Practice*, 16(2), 198-211. <https://doi.org/10.1039/C4RP00224E>
- Gilboy, M. B., Heinerichs, S., & Pazzaglia, G. (2015). Enhancing student engagement using the flipped classroom. *Journal of Nutrition Education and Behavior*, 47(1), 109-114. <https://doi.org/10.1016/j.jneb.2014.08.008>
- González-Gómez, D., Jeong, J. S., Airado Rodríguez, D., & Cañada-Cañada, F. (2016). Performance and perception in the flipped learning model: An initial approach to evaluate the effectiveness of a new teaching methodology in a general science classroom. *Journal of Science Education and Technology*, 25(3), 450-459. <https://doi.org/10.1007/s10956-016-9605-9>
- Hsu, C.-C., Chiu, C.-H., Lin, C.-H., & Wang, T.-I. (2015). Enhancing skill in constructing scientific explanations using a structured argumentation scaffold in scientific inquiry. *Computers & Education*, 91, 46-59. <https://doi.org/10.1016/j.compedu.2015.09.009>
- Hsu, S.-D., Chen, C.-J., Chang, W.-K., & Hu, Y.-J. (2016). An investigation of the outcomes of PGY students' cognition of and persistent behavior in learning through the intervention of the flipped classroom in Taiwan. *PLOS ONE*, 11(12), 1-14. <https://doi.org/10.1371/journal.pone.0167598>
- Huang, Y.-N., & Hong, Z.-R. (2016). The effects of a flipped English classroom intervention on students' information and communication technology and English reading comprehension. *Educational Technology Research and Development*, 64(2), 175-193. <https://doi.org/10.1007/s11423-015-9412-7>

- Hwang, F.-K., Tsai, C.-C. (2015). A review of features of technology-supported learning environments based on participants' perceptions. *Computers in Human Behavior, 53*, 223-237. <https://doi.org/10.1016/j.chb.2015.06.042>
- Joanne, C. S. M., & Lateef, F. (2014). The Flipped Classroom Viewpoints in Asian Universities. *Education in Medicine Journal, 6*(4), 20-26.
- Kim, B., Pathak, S. A., Jacobson, M. J., Zhang, B., & Gobert, J. D. (2015). Cycles of exploration, reflection, and consolidation in model-based learning of genetics. *Journal of Science Education and Technology, 24*(6), 789-802. <https://doi.org/10.1007/s10956-015-9564-6>
- Kong, S. C. (2015). An experience of a three-year study on the development of critical thinking skills in flipped secondary classrooms with pedagogical and technological support. *Computers & Education, 89*, 16-31. <https://doi.org/10.1016/j.compedu.2015.08.017>
- Lin, Y., Zhu, Y., Chen, C., Wang, W., Chen, T., Li, T., . . . Liu, Y. (2017). Facing the challenges in ophthalmology clerkship teaching: Is flipped classroom the answer? *PLOS ONE, 12*(4), e0174829. <https://doi.org/10.1371/journal.pone.0174829>
- Makransky, G., Bonde, M. T., Wulff, J. S. G., Wandall, J., Hood, M., Creed, P. A., . . . Nørremølle, A. (2016). Simulation based virtual learning environment in medical genetics counseling: An example of bridging the gap between theory and practice in medical education. *BMC Medical Education, 16*(1), 98. <https://doi.org/10.1186/s12909-016-0620-6>
- Moran, K., & Milsom, A. (2015). The flipped classroom in counselor education. *Counselor Education and Supervision, 54*(1), 32-43. <https://doi.org/10.1002/j.1556-6978.2015.00068.x>
- Nichols, K., Gillies, R., & Hedberg, J. (2016). Argumentation-based collaborative inquiry in science through representational work: Impact on primary students' representational fluency. *Research in Science Education, 46*(3), 343-364. <https://doi.org/10.1007/s11165-014-9456-4>
- Novak, J., Kensington-Miller, B., & Evans, T. (2017). Flip or flop? Students' perspectives of a flipped lecture in mathematics. *International Journal of Mathematical Education in Science and Technology, 48*(5), 647-658. <https://doi.org/10.1080/0020739X.2016.1267810>
- Porcaro, P. A., Jackson, D. E., McLaughlin, P. M., & O'Malley, C. J. (2016). Curriculum design of a flipped classroom to enhance haematology learning. *Journal of Science Education and Technology, 25*(3), 345-357. <https://doi.org/10.1007/s10956-015-9599-8>
- Rui, Z., Lian-Rui, X., Rong-Zheng, Y., Jing, Z., Xue-Hong, W., & Chuan, Z. (2017). Friend or foe? Flipped classroom for undergraduate electrocardiogram learning: A randomized controlled study. *BMC Medical Education, 17*(1), 1-9. <https://doi.org/10.1186/s12909-017-0881-8>
- Sarantos, P. (2016). Inquiry based-computational experiment, acquisition of threshold concepts and argumentation in science and mathematics education. *Journal of Educational Technology & Society, 19*(3), 282-293.
- Sletten, S. R. (2017). Investigating flipped learning: Student self-regulated learning, perceptions, and achievement in an introductory biology course. *Journal of Science Education and Technology, 26*(3), 347-358. <https://doi.org/10.1007/s10956-016-9683-8>
- Wang, J., Guo, D., & Jou, M. (2015). A study on the effects of model-based inquiry pedagogy on students' inquiry skills in a virtual physics lab. *Computers in Human Behavior, 49*, 658-669. <https://doi.org/10.1016/j.chb.2015.01.043>
- Wanner, T., & Palmer, E. (2015). Personalising learning: Exploring student and teacher perceptions about flexible learning and assessment in a flipped university course. *Computers & Education, 88*, 354-369. <https://doi.org/10.1016/j.compedu.2015.07.008>

<http://www.ejmste.com>

# An Efficient Approach to Slicing Learning Video to Improve Learning Effectiveness by Considering Learner Prior Knowledge

Chien-I Lee <sup>1\*</sup>, Chang-Lin Tsai <sup>1</sup>

<sup>1</sup> National University of Tainan, Tainan, TAIWAN

Received 3 May 2017 • Revised 4 February 2018 • Accepted 13 February 2018

## ABSTRACT

Video has become a popular tool in today's instructional environment, which also imposes additional cognition load for learners, thereby sabotaging their learning performance. To address this problem, researchers have attempted to slice video into smaller segments, known as the "segmentation effect," so as to reduce learners' cognition load. Therefore, this paper proffers appropriate strategies with which to slice a learning video aimed at learners with different levels of prior knowledge. This is expected to reduce the cognition load of learners of differing levels, ultimately increasing their learning efficiency. This study chose its research subjects from a primary school in the southern part of Taiwan. A random sampling was conducted to create three classes for this experiment, one class with 32 students as the control group, whereas the other two classes all with 34 students as experimental group 1 and experimental group 2, respectively. Research results indicate that whether a learner is endowed with high-level, intermediate-level, or low-level prior knowledge, all participants in the experimental group outperformed their counterparts in the control group. The results cannot be inferred to other grades of students. In the future, this research will also be extended to other courses or disciplines.

**Keywords:** segmentation effect, expertise reversal effect, learning effectiveness

## INTRODUCTION

Cutting-edge technology and widespread use of broadband networks enable us to easily interact with others wherever they are. Whether it be social sites like blogs and Facebook, or video-hosting websites like YouTube, web-surfers can easily share their life experiences, ideas, or notes taken in the learning process, over the internet. Some researchers even upload their research ideas or academic resources, so individuals with an interest in that field of study may learn from each other over this platform. These multimedia resources benefit teachers and students alike by providing a massive repertoire and convenient avenues for exploration. For example, a step-by-step solution to a math problem can be shown on a video (Ertelt, Renkl, & Spada, 2006). Video presents what is going on in the real world via audio/visual communications technologies (Paivio, 1986). This range of stimuli can strengthen learners' memories and impressions of the content while increasing their attention span. Moreover, the demonstrative effect rendered by video may help learners to reflect over the material at hand and enjoy the process of learning (Liu, Chen, & Chang, 2010).

When viewers watch a video, they not only have to identify a series of scenes and images and quickly understand how the current scene is related to the previous ones, they also need to connect new knowledge to what is already known. This is a huge task for the short-term memory and one that increases cognition load for learners, whose learning performance may suffer as a result (Hasler, Kersten, & Sweller, 2007; Spanjers, Van Gog, & van Merriënboer, 2010). To reduce cognition load, Mayer and Moreno (2003) suggested that a video be broken up into a series of small segments so viewers can better absorb the information and try to integrate the previous and newly acquired knowledge on their own. They called this the "segmentation effect". When Kalyuga, Ayres, Chandler, and Sweller (2003) examined a range of instructional techniques designed to address learner experience and reduce cognitive load, they advised that certain techniques can induce expertise reversal effect. Simply put, in expertise



### Contribution of this paper to the literature

- Both clustering technologies and concept mapping techniques are employed to break a video into several small pieces in order to accommodate the needs of learners with differing levels of prior knowledge and help them learn effectively.
- This study also prove that when teachers provide instructional video materials to their students, they need to take learners' prior knowledge, segmentation effect, and expertise reversal effect into account.
- This paper is the first research for primary school students by employing clustering technologies and concept mapping techniques in video segmentation, in order to examine how different strategies of segmentation help improve learner performance.

reversal the effect of instructional techniques correlates to learners' expertise in a reverse fashion. Scaffold instruction will likely lose its positive effect on more experienced learners, sometimes to the extent that learning performance is negatively affected (Dankbaar, Alsmas, Jansen, van Merriënboer, van Saase, & Schuit, 2016).

Research results indicate a negative correlation between instructional techniques and learners' domain knowledge and prior experience (Kalyuga, 2007, 2008; Leahy & Sweller, 2005; Reisslein, Atkinson, Seeling & Reisslein, 2006; Rey & Buchwald, 2011). Specifically speaking, video segmentation proves little value to seasoned learners (Spanjers, van Gog, Wouters, & van Merriënboer, 2012).

As expertise reversal effect tends to hinder the learning performance of experienced learners, it is necessary to determine an effective technique for the appropriate segmentation of instructional videos. In an effort to fill this gap, the present study examined a set of videos and asked participants to answer questions related to their prior knowledge. We then implemented clustering technologies (Xiaojun, 2017) to segment the videos. Although clustering technologies help save a lot of time and manpower in the video segmentation process, they might not be good at identifying explicit learning concepts.

Novak and Gowin (1984) proposed strategies to construct concept maps based on the assimilation theory developed by Ausubel, Novak and Hanesian in 1968. This theory stresses that prior knowledge helps learners comprehend a new concept and build a cognition relationship between old and new ideas. The technique of concept mapping can be used to help learners gain knowledge through their own current cognition structure, and further connect new cognition structure to previously built ones. According to Novak, a concept map helps students better express their comprehension and grasp the locus of thought. Through the visualization of relationships among different concepts, learners are able to organize information via a diagram that graphically depicts the relationships among concepts (Novak, 1990). Hence this study further employed the technique of concept mapping to discover participants' prior knowledge and to more accurately segment videos so as to accommodate the needs of novice and seasoned learners simultaneously (Hilbert & Renkl, 2009; Scheiter, Fillisch, Krebs, Leber, Ploetzner, Renkl, & Zimmermann, 2017; Soellner, Lenartz, & Rudinger, 2017).

With the research background and motivations in mind, this study employed three video segmentation strategies: undifferentiated video segmentation, video segmentation using clustering technologies, and video segmentation using concept mapping. Each student was given video clips that best suit their needs.

### Research Question

The specific research questions that guided this study are as follows:

- (1) How do the aforementioned three strategies affect learner performance?
- (2) How do the aforementioned three strategies affect learners with different levels of prior knowledge?

### Research Hypothesis

Based on the research questions, the hypotheses of this study are as follows:

- (1) Learners were provided with a video that was sliced using concept mapping techniques have better learning effectiveness than those with undifferentiated video segmentation and those with a video that was sliced using clustering technologies.
- (2) Learners with high-level prior knowledge have not significant difference in learning effectiveness when exposed to aforementioned three strategies. On the other hand, learners with intermediate-level and low-level learners would have significant improvement in learning when exposed to the video trimmed using concept mapping techniques.



## THEORETICAL FRAMEWORK

Mayer and Chandler (2001) conducted an experiment on college students to determine whether the segmentation of videos has an influence on learning outcomes. Results showed that participants who viewed a segmented video had a higher score in the “problem-solving and transfer” test than their counterparts (Mayer, 1997; Mayer & Chandler, 2001). Later, Mayer and Moreno (2003) presented a principle of instruction known as the “segmentation effect,” which advocates slicing a teaching material (as a video) into manageable pieces, so that learners have time to absorb the information at hand, one step at a time. This improves learners’ autonomy in setting a pace for themselves so all learners, whether they have sufficient prior knowledge or not, will succeed in their studies (Mayer & Chandler, 2001; Mayer & Moreno, 2003).

The reason why segmentation works wonders for learners may be because it reduces the cognition load on learners, especially novices who have difficulty in memorizing quickly passing information. It helps to fixate the attention of viewers on the video, by adding cut points at intervals. This way, learners are better able to understand ideas and process them into their knowledge frameworks. Meanwhile, cut points, like a temporal cueing, may help relieve stress and save cognition resources in processing information, as they function as boundaries between events. For a unit of instruction, temporal cueing suggests an embedded structure in instructional materials, so learners may learn something new in a more organized way (Spanjers et al., 2010; Spanjers, van Gog, Wouters, & van Merriënboer, 2011).

Furthermore, a learner’s professional knowledge is key to her/his attitude and reception of certain messages or knowledge. Higher-knowledge learners (also called experts) are equipped with many schemas of domain knowledge. Their stratified structure of knowledge lends itself to an advanced schema, which is produced from organization of multiple elements of certain knowledge (Carpenter, Lund, Coffman, Armstrong, Lamm, & Reason, 2016). This advanced schema is regarded as a single unit. When faced with elements of knowledge, experts know how to effectively employ them as working memory. These higher-level elements or units consume far less working memory resources than disorganized low-level elements. In other words, schemas are at experts’ disposal to handle massive amounts of information and then reduce working memory load. In addition, schema automation relieves the constraints on working memory for experts, so they can use as few resources as possible to resolve a problem (Kalyuga, 2005, 2007; Kalyuga & Sweller, 2004).

Learners’ acquisition of domain knowledge therefore determines how they integrate current and previous information using established schemas held in working memory. Novice learners do not master schemas that can help them solve problems or fulfil the task at hand. It follows that instructional designs that are scaffolded may help novices build schemas in processing new ideas. When an instructional design fails to provide structural guidance for learners, these learners must rely on lower-level elements for cues in finding possible solutions and will inevitably have to wrestle with heavy working memory load (Boucheix & Forestier, 2017).

To address this problem, the current study formulates three types of segmentation strategies: undifferentiated video segmentation, video segmentation using clustering technologies, and video segmentation using concept mapping. In this experiment, the independent variable is the type of segmentation; the control variables are instructional content and level of prior knowledge; the dependent variable is the performance of the learner in the post-test; and the covariate variable is the pre-test taken by a learner before she/he watches a segmented video. Variables are considered in more detail below:

(1) Independent variables:

(a) Undifferentiated video segmentation:

All participants were exposed to the same video segmented according to the same technique.

(b) Experimental group 1:

Learners were split into three groups based on their level of prior knowledge (measured by a pre-test) and then provided with a video that was segmented using clustering technologies.

(c) Experimental group 2:

Learners were split into three groups based on their level of prior knowledge (measured by a pre-test) and then provided with a video that was sliced using concept mapping techniques.

(2) Dependent variables

Learning outcomes: All three groups took a post-test to see what they had learned during the experimental activity.

**Table 1.** The number of students of different levels of prior knowledge

Group	Control group	Experiment group 1	Experiment group 2
High-level	10	10	10
Intermediate-level	13	14	14
Low-level	9	12	10

(3) Control variables:

(a) Instructional content:

The 5th-grade mathematics unit focusing on “Four Fundamental Operations of Arithmetic” was used as the teaching material.

(b) Test of prior knowledge:

A test was carried out among participants to determine their prior knowledge.

(c) All of the groups were taught by the same teacher.

(4) Covariate variable:

Pre-test: A pre-test and post-test were carried out in all three groups in order to examine differences in learning performance before and after the experiment.

## METHODOLOGY

### Research Framework and Participants

This study adopted a quasi-experimental design with one designated experimental group and two control groups comprising students. Taking time/manpower constraints and investigative and administrative procedures into consideration, this study chose its research subjects from a primary school in the urban area in the southern part of Taiwan. All were fifth graders and placed in a class of mixed ability. A random sampling was conducted to create three classes for this experiment. One class was designated as the “control group,” whereas the other two classes were “experimental group 1” and “experimental group 2”. Before the video-watching activity, a pre-test was carried out to measure prior knowledge regarding the learning material. An independent-sample t-test was used to analyze scores of the pre-test. No significant difference was detected among the three groups. Among them, the 32 pupils in the control group were supplied with a video using undifferentiated segmentation. The 36 participants in experimental group 1 were provided with a video that was trimmed using clustering technologies, whereas the 34 participants in experimental group 2 watched a video that was sliced into smaller pieces using concept mapping techniques. Additionally, the above three groups were each divided up into high-, intermediate-, and low-level knowledge types of learners. Details are shown in [Table 1](#).

### Research Tools

#### *An online video platform*

This video platform was built by the authors using PHP Hypertext Preprocessor coupled with MySQL Database. Users need to log in to the system and fill in personal information before registering as a member. Then they are given a learning video segmented according to their pre-test scores (shown in [Figure 1](#)). Users press any key for the video to continue from cut points, placing control of the pace of learning in their hands ([Figure 2](#)).

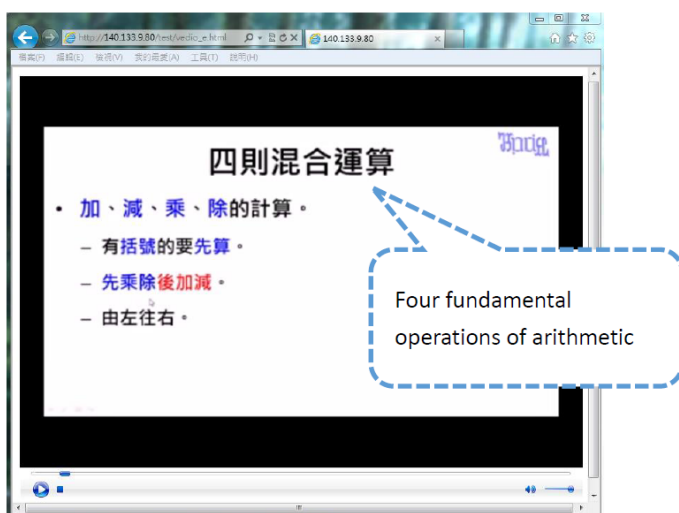


Figure 1. Screenshot of the video playback system

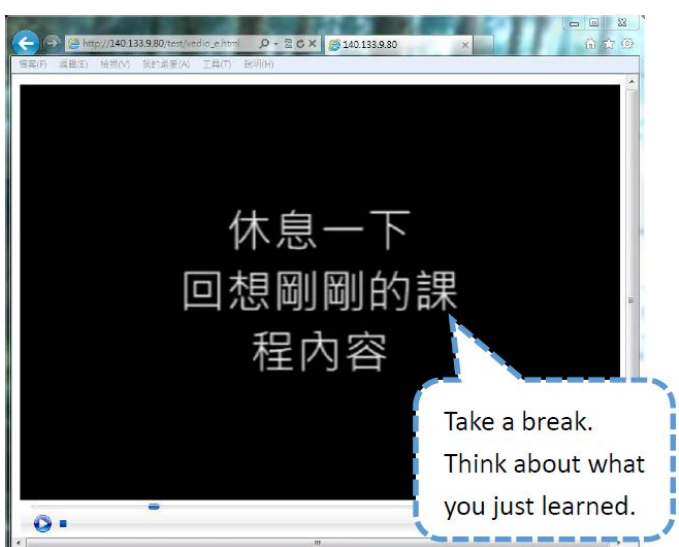


Figure 2. Screenshot of the cut point

Table 2. Two-way specification table of pre-test questions

Teaching objectives	Knowledge	Comprehension	Application	Analysis	Sum
Four fundamental operations of arithmetic	4	1	3	1	9
Distribution law	0	2	2	2	6
Sum	4	3	5	3	15

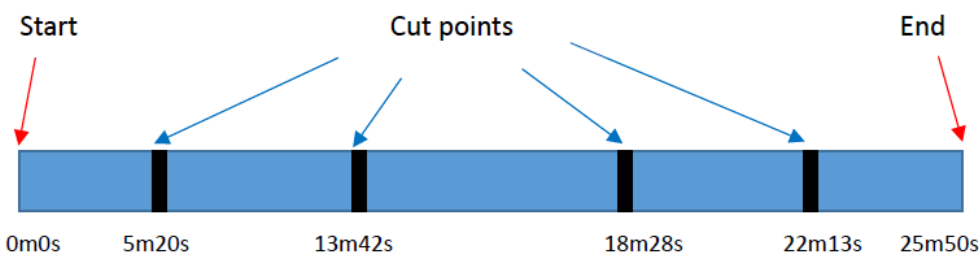
### Test items of pre- and post-test

The items in both pre- and post-tests were devised by five math teachers, each with over ten years' experience. The two-way specification table is presented in Table 2, which was drawn up in accordance with the taxonomy of cognition development developed by Bloom: knowledge, comprehension, application and analysis (Bloom, 1956). Of these test items, 4 were designed for knowledge, 3 for comprehension, 5 for application, and 5 for analysis.

As the results of pre-test analysis shown in Table 3, item discrimination was measured via the correct rate of the high-score minus the correct rate of low-score groups. Item difficulty analysis was measured by adding the two correct rates and then dividing them. The sample comprised 46 pupils, who were chosen from two classes of a primary school in southern Taiwan. The top and bottom 27% were categorized as the high-score and low-score groups, respectively. Lastly, the criteria for item difficulty and item discrimination was set between 0.2 and 0.8, and below 0.3, respectively. The item difficulty and item discrimination of Item 5 were 0.94 and 0.13, which was not a

**Table 3.** The result of pre-test analysis

Item	The correct rate of High-score groups	The correct rate of Low-score groups	Item difficulty	Item discrimination
1	0.93	0.10	0.52	0.83
2	0.96	0.20	0.58	0.76
3	0.93	0.27	0.60	0.66
4	0.87	0.03	0.45	0.84
5	1.00	0.87	0.94	0.13
6	1.00	0.37	0.69	0.63
7	0.97	0.53	0.75	0.44
8	0.97	0.17	0.57	0.80
9	0.93	0.57	0.75	0.36
10	1.00	0.60	0.80	0.40
11	1.00	0.57	0.79	0.43
12	0.97	0.60	0.79	0.37
13	0.97	0.43	0.70	0.54
14	0.97	0.43	0.70	0.54
15	0.90	0.20	0.55	0.70

**Figure 3.** The result of pre-test analysis

proper question. Item 5 needed to be revised to meet the above criteria. After revision, the reliability of the pre-test is 0.810 ( $> 0.7$ ), demonstrating good reliability.

After the experiment, all students (from two experimental groups and one control group) were asked to take a post-test in order to gauge the participants' learning performance during the experiment. After the validity of the post-test was confirmed, item difficulty and item discrimination were analyzed to decide if any items should be revised. The criteria for such revisions were identical to those of the pre-test, and were later used as guidelines for test optimization. The sample (of 44 pupils) was also taken from two another classes of a primary school in southern Taiwan. The post-test's reliability reaches 0.832 ( $> 0.7$ ), demonstrating good reliability.

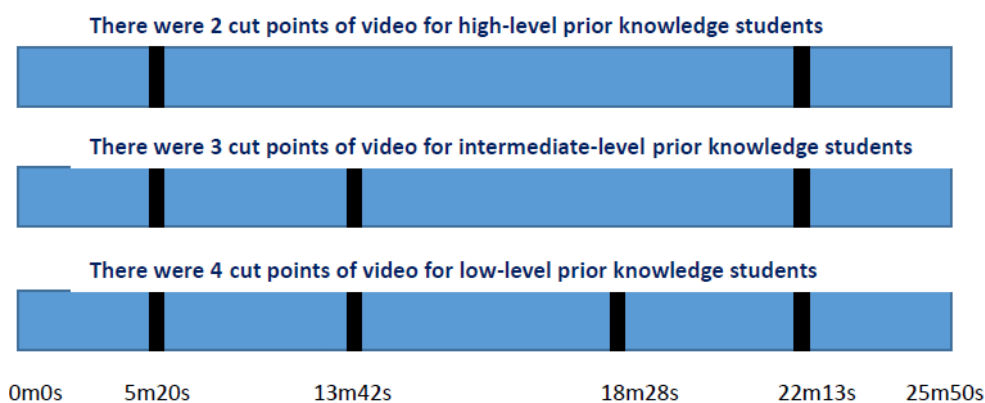
### Experimental Design and Procedures

The 3-stage experiment was conducted as follows:

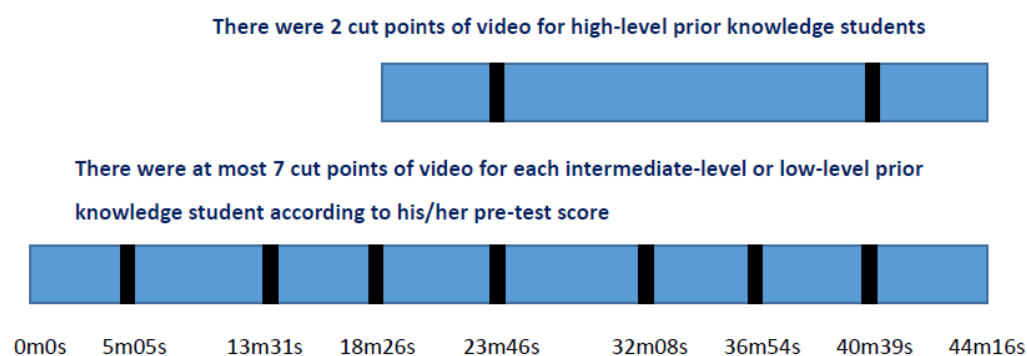
- (1) Pre-test: A pre-test was carried out in all groups (one control group and two experimental groups) to measure the level of their prior knowledge.
- (2) Learning activity: This activity was divided into two steps:
  - (a) On the day of the experiment, an explanation and demonstration were provided for the learners to teach them how to operate the video player interface.
  - (b) Users were engaged in video learning activity.
- (3) Post-test: A post-test was carried out among all participants after the video learning activity was over.

Participants were shown an animated video focusing on step-by-step solutions to math problems. For the control group and experimental group 1, the video lasted 25 mins and 50 secs. For experimental group 2, the video lasted 44 mins and 16 secs. This period was interspersed with a lot of cut points. The number and positions of cut points varied according to the participants' prior knowledge.

**Figure 3** presents a flow chart of the video watching activity designed for the control group. All participants, regardless of their level of prior knowledge as determined by the pre-test, were presented with the video with identical length and positions of cut points.



**Figure 4.** The process of video watching activity in experiment group 1



**Figure 5.** The process of video watching activity in experiment group 2

In **Figure 4**, there is a flow chart of the video watching activity designed for experimental group 1. Participants were split into three groups based on their pre-test results, and each group was presented with a video that was sliced at different positions according to the viewer's level of prior knowledge. For those with high-level prior knowledge, two cut points were set at 5'20" and 22'13". For those with intermediate-level prior knowledge, three cut points were set at 5'20", 13'42", and 22'13". For those with low-level prior knowledge, four cut points were set at 5'20", 13'42", 18'28", and 22'13". The cut points of video for each group were carefully determined by the teachers with their teaching experiences of "Four Fundamental Operations of Arithmetic" according to the prior knowledge of these three groups, respectively. Basically, the lower the prior knowledge, the more cut points were set.

**Figure 5** shows a flow chart of the video watching activity designed for experimental group 2. As shown in **Figure 6**, the concept map was used to trim the video by the teacher previously. Participants were split into three groups based on their pre-test results, and each group was presented with a video that was cut at different positions according to the viewer's level of prior knowledge. For those with high-level prior knowledge, two cut points were set at 5'20" and 22'13". For those with intermediate-level prior knowledge, three cut points were set at 5'20", 13'42", and 22'13". For those with low-level prior knowledge, four cut points were set at 5'20", 13'42", 18'28", and 22'13". In addition to an animated video focusing on step-by-step solutions to math problems, other videos focusing on similar concepts were provided as well. For learners with high-level prior knowledge, two cut points were set at 5'20" and 22'13". The intermediate- and low-level groups were shown different videos focusing on feature similar concepts before watching the target video. The maximum number of cut points was 7 points at 5'05", 13'31", 18'26", 23'46", 32'08", 36'54", and 40'39".

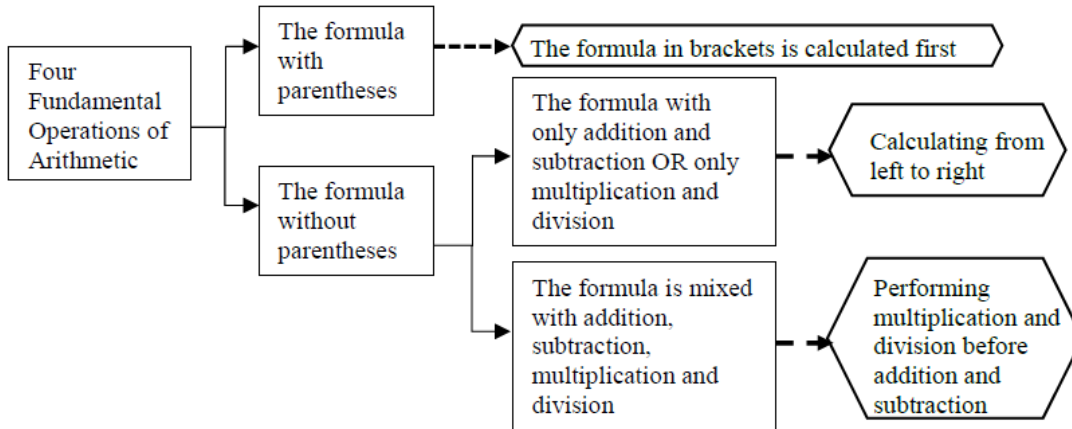


Figure 6. The concept map of “Four Fundamental Operations of Arithmetic”

Table 4. Paired samples t-test results of the pre-test and post-test within control group

	N	M	SD	p
Pre-test	32	71.19	20.287	
Post-test	32	85.69	15.782	.002**

\*p<.05 \*\*p<.01

Table 5. Paired samples t-test results of the pre-test and post-test within experiment group 1

	N	M	SD	p
Pre-test	36	66.00	26.679	
Post-test	36	81.33	24.699	.000***

\*p<.05 \*\*p<.01 \*\*\*p<.001

Table 6. Paired samples t-test results of the pre-test and post-test within experiment group 2

	N	M	SD	p
Pre-test	34	66.65	22.871	
Post-test	34	82.41	26.029	.000***

\*p<.05 \*\*p<.01 \*\*\*p<.001

Table 7. ANCOVA analysis of learning effectiveness between control group and experiment group 1

	N	M	SD	F
Control group	32	85.69	15.782	
Experiment group 1	36	81.33	20.946	2.257

## RESULTS

### Analysis of Pre- and Post-tests

All three groups of participants were provided with pre-and-after tests; therefore we performed a paired sample t-test to compare learning performances. Table 4 demonstrates that the control group received an average score of 85.69 in the post-test, significantly higher than 71.19 of the pre-test ( $t = -4.608, p < 0.01$ ). Similarly, experimental group 1 (clustering technology) obtained an average score of 81.33 in the post-test, significantly higher than 66.00 in the pre-test ( $t = -4.364, p < 0.001$ ), shown in Table 5. Table 6 shows that experimental group 2 (concept mapping technique) obtained an average score of 82.41 in the post-test, significantly higher than 66.65 of the pre-test ( $t = -4.727, p < 0.001$ ). In all three groups, the score of the post-test in learning performance was significantly higher than that of the pre-test.

### Analysis of Influence of Video Segmentation on Learning Outcomes

We performed ANCOVA to verify whether undifferentiated video segmentation, video segmentation using clustering technologies, and video segmentation using concept mapping technique, would exhibit different learning outcomes in pairs of comparison. Results are shown in Tables 7, 8, and 9.



**Table 8.** ANCOVA analysis of learning effectiveness between control group and experiment group 2

	<b>N</b>	<b>M</b>	<b>SD</b>	<b>F</b>
Control group	32	85.69	15.782	2.619
Experiment group 2	34	82.41	26.029	

**Table 9.** ANCOVA analysis of learning effectiveness between experiment group 1 and experiment group 2

	<b>N</b>	<b>M</b>	<b>SD</b>	<b>F</b>
Experiment group 1	36	81.33	20.946	.001
Experiment group 2	34	82.41	26.029	

**Table 10.** Paired samples t-test results of the pre-test and post-test of different levels of prior knowledge within control group

<b>Level</b>		<b>N</b>	<b>M</b>	<b>SD</b>	<b>p</b>
High-level	pre-test	10	95.60	5.060	.653
	post-test	10	94.80	5.514	
Intermediate-level	pre-test	13	69.85	7.894	.004**
	post-test	13	83.69	18.273	
Low-level	pre-test	9	46.00	46.00	.000***
	post-test	9	78.44	16.149	

\*p < .05 \*\*p < .01 \*\*\*p < .001

**Table 11.** Paired samples t-test results of the pre-test and post-test of different levels of prior knowledge within experiment group 1

<b>Level</b>		<b>N</b>	<b>M</b>	<b>SD</b>	<b>p</b>
High-level	pre-test	12	96.00	5.326	1.000
	post-test	12	96.00	5.326	
Intermediate-level	pre-test	14	64.29	9.343	.006**
	post-test	14	85.43	21.661	
Low-level	pre-test	10	32.40	12.176	.002***
	post-test	10	58.00	27.244	

\*p < .05 \*\*p < .01 \*\*\*p < .001

In **Table 7**, the output of ANCOVA ( $F(1,62) = 2.257, p > .05$ ) reveals a non-significant difference between the control group and experimental group 1. In **Table 8**, the output of ANCOVA ( $F = 2.619, p > .05$ ) reveals a non-significant difference between the control group and experimental group 2. **Table 9** also shows a corresponding result in the learning outcomes of experimental group 1 and experimental group 2 ( $F = .001, p > .05$ ).

To explore why different strategies of segmentation did not have a significant impact on learners, this study performed a paired sample t-test on the pre- and post-tests undertaken by high-, intermediate-, and low-level learners of the aforementioned three groups.

### *Control group: undifferentiated video segmentation*

**Table 10** shows the learning outcomes of high-level learners before and after watching the undifferentiated segmented video. The pre-test confirmed that these learners already had some understanding of step-by-step solutions to math problems. When they were engaged in the video learning activity, cut points (temporal cueing) seemed unnecessary for them because these pauses interfered with their learning process. Learners with intermediate- and low-level knowledge obtained higher scores in the post-test than in the pre-test. While both showed significant difference in their learning performance, the difference in low-level learners was more significant ( $p < 0.001$ ).

### *Experimental group 1: segmentation using clustering technology*

**Table 11** reveals the three levels of learners' outcomes produced before and after watching the video trimmed using clustering technologies. The data reveals that high-level learners were not significantly affected by this video using clustering technologies, which might be because they have already have a knack for acquiring new knowledge. On the other hand, intermediate- and low-level learners obtained a significantly higher score in their post-test. The significant levels were  $< 0.01$ . Therefore segmentation through clustering technologies helped increase the learning performance of intermediate- and low-level participants.

**Table 12.** Paired samples t-test results of the pre-test and post-test of different levels of prior knowledge within experiment group 2

Level		N	M	SD	p
High-level	pre-test	10	94.00	6.864	.833
	post-test	10	94.60	9.046	
Intermediate-level	pre-test	14	66.71	6.157	.000**
	post-test	14	89.14	19.732	
Low-level	pre-test	10	39.20	12.155	.018***
	post-test	10	60.80	32.947	

\*p &lt; .05 \*\*p &lt; .01 \*\*\*p &lt; .001

### *Experimental group 2: segmentation using concept mapping technique*

**Table 12** shows the three levels of learners' outcomes produced before and after watching the video trimmed using concept mapping techniques. According to the data, high-level learners showed a slightly higher score in the post-test than the pre-test, yet the t-test result exhibited little difference. This might be because learners with high-level prior knowledge are skilled at integrating new material, and are not subject to outside influences. Intermediate-level learners, however, scored significantly higher in the post-test ( $p < 0.001$ ). This was presumed to be because learners of this group benefitted from the video using concept mapping techniques, and have a fuller understanding of relevant ideas, thereby achieving efficiency in learning. Low-level learners obtained higher scores in the post-test after watching the video trimmed using concept mapping techniques. However, the significance level ( $p < 0.05$ ) was lower than the undifferentiated and clustering technology groups. It was inferred to be due to the excessive length of this video, which caused an attention problem. Secondly, this might be because these low-level learners did not have adequate command of concepts before watching this video, and had difficulty in comprehending the content of this video.

The above analytical results validate that the three types of learners benefit from different methods of video segmentation. Learners with high-level prior knowledge did not show significant difference in learning performance when exposed to three differently segmented videos. Intermediate-level learners showed significant improvement in learning when exposed to the video trimmed using concept mapping techniques. Low-level learners made significant progress after watching the videos trimmed with undifferentiated segmentation and clustering technologies.

## DISCUSSION AND CONCLUSION

Segmentation has a significant influence on learner performance. Previous studies investigated segmentation in which cut points were manually controlled by users; this study is the first to employ clustering technologies and concept mapping techniques in video segmentation, in order to examine how different strategies of segmentation help improve learner performance. Results validate the existence of segmentation effect. Additionally, the research hypothesis (1) is valid, that is, learners were provided with a video that was sliced using concept mapping techniques have better learning effectiveness than those with undifferentiated video segmentation and those with a video that was sliced using clustering technologies. Besides, learners with intermediate-level and low-level learners would have significant improvement in learning when exposed to the video trimmed using concept mapping techniques, but, learners with high-level prior knowledge have not significant difference in learning effectiveness when exposed to aforementioned three strategies.

Moreover, the research hypothesis (2) is also valid, it was revealed that high-level learners did not show significant improvement in their learning outcomes. More surprisingly, when high-level learners were exposed to a video with undifferentiated segmentation, a reverse effect was found in their learning outcomes, which validate the existence of expertise reversal effect (Chen, Kalyuga & Sweller, 2017).

Even though different types of learners might benefit from different strategies of video segmentation and show improvement in their learning outcomes, it is worth noting that the intermediate-level learners who watched a video using concept mapping technique performed much better than their counterparts watching a video trimmed with clustering technologies. The instructor of the concept mapping group needed to spend additional time reviewing relevant concepts in that field of knowledge and checking cut points. Conversely, although the intermediate-and low-level learners watching a video using clustering technology did not show significant improvement, the instructor of that group was not required to spend extra time reviewing an array of concepts and checking cut points. Hence the two strategies of video segmentation, clustering vs. concept mapping, each have their own advantages and disadvantages. Instructor and learner attributes must be considered in the selection of the method most appropriate for the target audience (Blayney, Kalyuga & Sweller, 2016).

## RESEARCH LIMITATION AND FURTHER RECOMMENDATION

Due to the limitation of experimental time and teaching environment, all participants in this study were fifth graders from a primary school in the urban area in the southern part of Taiwan. The results of this study cannot be inferred to other grades of students.

Besides, an instructor needs to take learners' prior knowledge, segmentation effect, and expertise reversal effect into account when she/he provides instructional video materials. Clustering technologies have a relatively modest effect on learner performance, yet this strategy is less time-consuming. Conversely, the concept mapping technique remarkably increases learner performance, yet it requires high investment from the teacher. In the future, more data mining technologies (Han, Kamber, & Pei, 2011) would be applied in the development of the segmentation strategy during the learning process, which could automatically analyze and then segment video for an individual learner more effectively and efficiently aid in the improvement of learning performance.

## REFERENCES

- Ausubel, D. P., Novak, J. D., & Hanesian, H. (1968). *Educational psychology: A cognitive view*. New York: Holt, Rinehart and Winston.
- Blayney, P., Kalyuga, S., & Sweller, J. (2016). The impact of complexity on the expertise reversal effect: experimental evidence from testing accounting students. *Educational Psychology*, 36(10), 1868-1885. <https://doi.org/10.1080/01443410.2015.1051949>
- Bloom, B. S., (Ed.). (1956). *Taxonomy of educational objectives: The classification of educational goals: Handbook I, cognitive domain*. New York: Longman.
- Boucheix, J. M., & Forestier, C. (2017). Reducing the transience effect of animations does not (always) lead to better performance in children learning a complex hand procedure. *Computers in Human Behavior*, 69, 358-370. <https://doi.org/10.1016/j.chb.2016.12.029>
- Carpenter, S. K., Lund, T. J., Coffman, C. R., Armstrong, P. I., Lamm, M. H., & Reason, R. D. (2016). A classroom study on the relationship between student achievement and retrieval-enhanced learning. *Educational Psychology Review*, 28(2), 353-375. <https://doi.org/10.1007/s10648-015-9311-9>
- Chen, O., Kalyuga, S., & Sweller, J. (2017). The expertise reversal effect is a variant of the more general element interactivity effect. *Educational Psychology Review*, 29(2), 393-405. <https://doi.org/10.1007/s10648-016-9359-1>
- Dankbaar, M. E., Alsmas, J., Jansen, E. E., van Merriënboer, J. J., van Saase, J. L., & Schuit, S. C. (2016). An experimental study on the effects of a simulation game on students' clinical cognitive skills and motivation. *Advances in Health Sciences Education*, 21(3), 505-521. <https://doi.org/10.1007/s10459-015-9641-x>
- Ertelt, A., Renkl, A., & Spada, H. (2006). Making a difference: exploiting the full potential of instructionally designed on-screen videos. In *Proceedings of the 7th International Conference on Learning Sciences*, 154-160.
- Han, J., Kamber, M., & Pei, J. (2011). *Data mining: concepts and techniques* (3rd ed.). Burlington, Massachusetts, USA: Morgan Kaufmann.
- Hasler, B. S., Kersten, B., & Sweller, J. (2007). Learner control, cognitive load and instructional animation. *Applied cognitive psychology*, 21(6), 713-729. <https://doi.org/10.1002/acp.1345>
- Hilbert, T. S., & Renkl, A. (2009). Learning how to use a computer-based concept-mapping tool: Self-explaining examples helps. *Computers in Human Behavior*, 25(2), 267-274. <https://doi.org/10.1016/j.chb.2008.12.006>
- Kalyuga, S. (2005). Effects of prior knowledge on multimedia learning: Does expertise reverse and how to manage it? In *EdMedia: World Conference on Educational Media and Technology*, 2005(1), 3164-3171.
- Kalyuga, S. (2007). Expertise reversal effect and its implications for learner-tailored instruction. *Educational Psychology Review*, 19(4), 509-539. <https://doi.org/10.1007/s10648-007-9054-3>
- Kalyuga, S. (2008). Relative effectiveness of animated and static diagrams: An effect of learner prior knowledge. *Computers in Human Behavior*, 24(3), 852-861. <https://doi.org/10.1016/j.chb.2007.02.018>
- Kalyuga, S., & Sweller, J. (2004). Measuring knowledge to optimize cognitive load factors during instruction. *Journal of Educational Psychology*, 96(3), 558-568. <https://doi.org/10.1037/0022-0663.96.3.558>
- Kalyuga, S., Ayres, P., Chandler, P., & Sweller, J. (2003). The expertise reversal effect. *Educational Psychologist*, 38(1), 23-31. [https://doi.org/10.1207/S15326985EP3801\\_4](https://doi.org/10.1207/S15326985EP3801_4)
- Leahy, W., & Sweller, J. (2005). Interactions among the imagination, expertise reversal, and element interactivity effects. *Journal of Experimental Psychology: Applied*, 11(4), 266. <https://doi.org/10.1037/1076-898X.11.4.266>

- Liu, P. L., Chen, C.J., & Chang, Y.J. (2010). Effects of a computer-assisted concept mapping learning strategy on EFL college students' English reading comprehension. *Computers & Education*, 54(2), 436-445. <https://doi.org/10.1016/j.compedu.2009.08.027>
- Mayer, R. E. (1997). Multimedia learning: Are we asking the right questions? *Educational psychologist*, 32(1), 1-19. [https://doi.org/10.1207/s15326985ep3201\\_1](https://doi.org/10.1207/s15326985ep3201_1)
- Mayer, R. E., & Chandler, P. (2001). When learning is just a click away: Does simple user interaction foster deeper understanding of multimedia messages? *Journal of educational psychology*, 93(2), 390. <https://doi.org/10.1037/0022-0663.93.2.390>
- Mayer, R. E., & Moreno, R. (2003). Nine ways to reduce cognitive load in multimedia learning. *Educational psychologist*, 38(1), 43-52. [https://doi.org/10.1207/S15326985EP3801\\_6](https://doi.org/10.1207/S15326985EP3801_6)
- Novak, J. D. (1990). Concept maps and Vee diagrams: Two metacognitive tools to facilitate meaningful learning. *Instructional science*, 19(1), 29-52. <https://doi.org/10.1007/BF00377984>
- Novak, J. D., & Gowin, D. B. (1984). *Learning how to learn*. Cambridge, UK: Cambridge University Press. <https://doi.org/10.1017/CBO9781139173469>
- Paivio, A. (1986). *Mental representations: A dual coding approach*. New York, USA: Oxford University Press.
- Reisslein, J., Atkinson, R.K., Seeling, P., & Reisslein, M. (2006). Encountering the expertise reversal effect with a computer-based environment on electrical circuit analysis. *Learning and Instruction*, 16(2), 92-103. <https://doi.org/10.1016/j.learninstruc.2006.02.008>
- Rey, G. D., & Buchwald, F. (2011). The expertise reversal effect: Cognitive load and motivational explanations. *Journal of Experimental Psychology: Applied*, 17(1), 33. <https://doi.org/10.1037/a0022243>
- Scheiter, K., Fillisch, B., Krebs, M. C., Leber, J., Ploetzner, R., Renkl, A., & Zimmermann, G. (2017). How to Design Adaptive Information Environments to Support Self-Regulated Learning with Multimedia. In *Informational Environments* (pp. 203-223). Springer, Cham. [https://doi.org/10.1007/978-3-319-64274-1\\_9](https://doi.org/10.1007/978-3-319-64274-1_9)
- Soellner, R., Lenartz, N., & Rudinger, G. (2017). Concept mapping as an approach for expert-guided model building: The example of health literacy. *Evaluation and Program Planning*, 60, 245-253. <https://doi.org/10.1016/j.evalprogplan.2016.10.007>
- Spanjers, I. A. E., Van Gog, T., & van Merriënboer, J. J. G. (2010). A theoretical analysis of how segmentation of dynamic visualizations optimizes students' learning. *Educational Psychology Review*, 22(4), 411-423. <https://doi.org/10.1007/s10648-010-9135-6>
- Spanjers, I. A. E., van Gog, T., Wouters, P., & van Merriënboer, J. J. G. (2012). Explaining the segmentation effect in learning from animations: The role of pausing and temporal cueing. *Computers & Education*, 59(2), 274-280. <https://doi.org/10.1016/j.compedu.2011.12.024>
- Spanjers, I. A. E., Wouters, P., Van Gog, T., & Van Merriënboer, J. J. G. (2011). An expertise reversal effect of segmentation in learning from animated worked-out examples. *Computers in Human Behavior*, 27(1), 46-52. <https://doi.org/10.1016/j.chb.2010.05.011>
- Xiaojun, L. (2017). An improved clustering-based collaborative filtering recommendation algorithm. *Cluster Computing*, 1-8. <https://doi.org/10.1007/s10586-017-0807-6>

<http://www.ejmste.com>

## Study of Continuing Medical Education, Job Stress and Sleep Quality in Health and Medicine Industry – The Impact Relatedness

Yu-Zhou Luo <sup>1\*</sup>, Zhao-Yan Hu <sup>1</sup>, Fang Xu <sup>2</sup>, Rui Wang <sup>2</sup>

<sup>1</sup> School of Medical Instruments, Shanghai University of Medicine & Health Sciences, 279 ZhouZhu Road, Shanghai, CHINA

<sup>2</sup> Micro Mechatronics Laboratory, Graduate School of Science and Engineering, Yamaguchi University, 2-16-1 Tokiwadai, Ube, JAPAN

Received 25 October 2017 • Revised 8 January 2018 • Accepted 1 March 2018

### ABSTRACT

The development of medical technology has largely enhanced physicians' professional responsibilities. Besides, the emergence of consumer rights, patients' awakening of human right awareness, and the intervention of insurance have healthcare quality and physicians' professional abilities gradually become the focus of health policies. The importance of continuing medical education is therefore highlighted. With nonequivalent pretest posttest control group design, two hospitals in Hubei Province are studied. One is proceeded continuing medical education, while the other maintains the original situation without continuing medical education. The experimental study is preceded for half a year. The research results show that 1.continuing medical education would affect job stress, 2.continuing medical education would influence sleep quality, 3.job stress presents significantly negative effects on sleeping time in sleep quality, and 4.job stress shows remarkably negative effects on quality level in sleep quality. According to the results, suggestions are proposed, expecting to enhance healthcare staff's physiological and psychological health, promote job safety and performance, reduce medical incidents, and enhance healthcare service quality.

**Keywords:** healthcare industry, continuing medical education, job stress, sleep quality

### INTRODUCTION

Healthcare staff has to continue learning due to the large development of medical technology, the large enhancement of physicians' professional responsibilities, and the emphasis on evidence-based medicine and medicine ethics in past years. Furthermore, the emergence of consumer rights, patients' awakening of human right awareness, and the intervention of insurance have the maintenance of healthcare quality and physicians' professional abilities become the focus of health policies. The importance of continuing medical education (CME) is therefore gradually highlighted. A lot of healthcare staff is proud of themselves being the public health protectors and takes the harsh role in health care. The emphasis on nursing staff's health is the basis of patients' safe health care. In face of the changes of healthcare environment, patients' rise of customer awareness, cost concept, and accreditation systems in past years, the huge job stress of nursing staff might harm the physiological and psychological health as well as influence the overall service quality of an institute. Under the heavy health care burden, healthcare staff's health conditions are worth concerning, as healthy patients rely on healthy healthcare staff's high-quality and safer healthcare environment. Healthcare staff, with the highest ratio in the work team in a hospital, is responsible for taking care of patients and assisting in physicians and administrative services. Medical professional is a science as well as an art to concern about people and enhance human health. In addition to assisting in physicians, healthcare staff also plays a critical role between physicians and patients and doctor-patient relationship. The transformation of time enhances the high technology of health care that the public have enhanced the requirements. Medical professionals do not simply take care of patients, but also take the responsibilities for



#### **Contribution of this paper to the literature**

- It is essential to practice continuing medical education system for enhancing healthcare staff's sleep and healthcare quality.
- Qualified teachers of continuing medical education should be established the database and requested the intention to conduct education plans. Teachers' practice should be reasonably evaluated, such as having the organizers fill in evaluation tables and opinions after the continuing medical education.
- The time, location, contents, and places for continuing medical education should be taken into account for healthcare staff's suitability and convenience.

ethics. Medical work is a high-profession and high-stress occupation that it is more easily to result in poor physical and mental symptoms, such as fatigue, muscular tension, pain, anxiety, depression, and poor sleep.

Medical manpower shortage and frequent turnover are the harsh challenges for hospitals; besides, the problems of excessive squeezing and sweat hospitals have continuously induced the public concerns. Healthcare staff often suffers from declined sleep quality and physical & mental fatigue due to responsibility system, shift, and overtime work; more seriously, it might harm patients' safety because of nursing staff's fault. Shift workers often complain about sleep disorder and not recovering from fatigue. Moreover, sleep is closely related to health. For this reason, healthcare staff's continuing medical education toward job stress and sleep quality is discussed in this study, expecting to enhance healthcare staff's physiological and psychological health, enhance job safety and performance, reduce medical incidents, and promote healthcare service quality.

## **LITERATURE AND HYPOTHESIS**

### **Continuing Medical Education**

Education is a purposive and planned learning process (Jeong et al., 2013). Campion (2015) definitely explained continuing education as a planned education activity for people returning to formal schools' education system, including non-traditional students in the USA and those being interested in adult education. The definition was gradually reduced the coverage; and now, the common definition refers to "adult education programs provided for profession and occupation oriented advanced training" (Kivimäki, Singh-Manoux, Nyberg, & Batty, 2013). Healthcare staff's continuing education refers to educational activity for continuing professional development, i.e. the provision of knowledge for the professional growth and professional continuing education activity required for enhancing work effectiveness (Chiou et al., 2014). Michl, McLaughlin, Shepherd, and Nolen-Hoeksema (2013) defined continuing medical education as the education or training for enhancing or developing the abilities of medical professional knowledge, the inference and explanation abilities, and appropriate professional skills to complete the doctor-patient relationship standards or capability. Continuing medical education, focusing on knowledge and skills, should be accredited and agreed by professional staff, including basic medicine science, clinical guidelines, and public health care norms (Chou, Li, & Hu, 2014). Walters et al. (2013) revealed continuing medical education as a planned activity and training, which allowed nursing staff enhancing the professional abilities of clinical work, teaching, research, and administrative management through professional knowledge or skills to eventually promote healthcare quality (Hatherill et al., 2016). Pritchard (2017) indicated that both science and humanities should be emphasized in continuing medical education for the constant acquisition of new knowledge and self-development so as to constantly learn and make progress in the medical career. Lee et al. (2015) regarded continuing medical education aimed to improve physicians' knowledge, attitudes, and techniques as well as continue the latest knowledge to improve the process and result of patients' care, assist physicians in accepting or refusing new medical techniques, and helping physicians distinguish care with less effectiveness.

### **Job Stress**

Stress, being the subjective feeling, refers to the interactive relationship presented in individual life to cope with the constantly changing environment, i.e. the changing perception when an individual physiologically and psychologically encountering the environment (Lesuffleur, Chastang, Sandret, & Niedhammer, 2014). Åkesson, Larsson, Discacciati, and Wolk (2014) stated that people would experience three stages of alarm, resistance, and collapse, when encountering long-term and continuous stress. In the process, a series of physiological responses would be generated, called general adaptation syndrome (GAS). Job stress is the conceptualization process, implying individual cognition and response to the threats or danger of certain work characteristics in the work environment (Kivimäki et al., 2015). Davey et al. (2015) pointed out job stress as a dynamic process with continuous changes, rather than static and disconnected phenomena. Job stress was the specific result of constant coordination and interaction between an individual and the environment; and, subjectivity, interactivity, history, and specificity



were the essence of job stress. Different individuals would perceive distinct stress on the same potential stress source, and the effects on individuals would not be identical. When an individual could not acquire the balance with the job, job stress was resulted from individual physical and mental unbalance because of work requirements or the expectation of self-actualization in the work environment (Nyberget al., 2013). Heinen et al. (2013) defined job stress as the response harmful for body or emotion when the work requirement could not conform to the worker's capability, resources, or personal needs; job stress would result in bad health and even cause damage (Touré et al., 2016). Johns and Jepsen (2015) proposed experts' definition of job stress as the job requirements not being able to conform to the worker's responsibility, resources, or job needs.

The "nursing staff's stress scale" developed by Cheng et al. (2014) is used for measuring nursing staff's stress in this study. The scale contains four dimensions.

- (1) Personal response: To understand nursing staff's perceived personal and physical/mental symptoms.
- (2) Work concern: To understand nursing staff's perception of healthcare team's communication and coordination as well as the capability of medical professional role.
- (3) Work competency: To understand nursing staff's confidence in completing nursing and healthcare work on time.
- (4) Private work: To understand nursing staff's perceived personal and family time management.

### Sleep Quality

Sleep, as a physiological behavior, refers to a person, without consciousness of external environment, being awakened by external stimuli (Kang et al., 2014). Sleep takes about one-third of time in human life. The process of sleep presented reversible reduction of perceptual sensitivity and decreasing muscular tension that the immune system could recover the damaged cells and tissues, when spirit and energy are thoroughly rested, to keep balanced physiological, psychological, and emotional health (O'Keefe & Lavie, 2013). Ansoleaga (2015) regarded sleep quality as the indicator showing good physiological and psychological state. The level of sleep quality could result in physical or functional disorder, and good sleep could predict or grasp the trend of diseases (Vijendren, Yung, & Sanchez, 2015). Lee et al. (2014) considered that sleep quality evaluation should cover perceived night sleep and time for continuing sleep. With sequence, Go et al. (2013) proposed three dimensions to evaluate sleep quality, including being easy to fall asleep, integrated sleep cycle, and behavior and rest after getting up. Wong, Amsterdam, and Blumenthal (2015) regarded sleep quality as individual sleep pattern and subjective sleep satisfaction, including the spiritual state in daytime, perceived sleep hour, and perceived sleep satisfaction. Among the factors in overall sleep quality, subjective sleep quality appeared the strongest relationship with overall sleep quality, followed by sleep latency and sleep disturbance. The subjective perception of bad sleep quality might be caused by long sleep latency or sleep disturbance (Hsu et al., 2015).

Lin et al. (2015) indicated that the level of sleep quality could be judged subjectively and objectively. Objective evaluation could be delivered the sleep situation of the case through equipment, and subjective evaluation referred to the case judging the time to fall asleep, the level of sleep quality, and the adequacy. Referring to Chou and Hu (2015), subjective evaluation is applied to measure sleep quality with sleeping time and quality level.

### Research Hypothesis

Davey et al. (2015) mentioned that, with the rapidly increasing new knowledge in basic medicine science, preventive medicine, and clinical medicine as well as the rapid advance of medical technology development, continuing medical education could ensure physicians presenting adequate professional abilities and being competent of medical businesses in the future career to reduce physicians' job stress and enhance the healthcare quality (Touré et al., 2016). Pritchard (2017) explained that continuing medical education as the education or training to enhance or develop professional medical knowledge, the abilities of inference and explanation, and appropriate professional skills to complete the doctor-patient relationship standard or ability and effectively reduce medical staff's job stress (Hatherill et al., 2016). Johns and Jepsen (2015) considered that continuing medical education could have healthcare staff master the abilities and techniques related to the job to face the changeable medical conditions and reduce work load and stress. Such a process would continue from the graduation from schools to the retirement. The following hypothesis is therefore proposed in this study.

**H1:** Continuing medical education would affect job stress.

Wong et al. (2015) explained continuing medical education as a planned learning, exceeding basic education and aiming to enhance healthcare staff's knowledge, skills, and attitudes to reinforce medical practical ability, reduce job stress caused by medical work, and enhance work adjustment and sleep quality; and, promoting the public health care was the top goal (Vijendren et al., 2015). Lee et al. (2015) indicated that several researchers also mentioned to provide a series of teaching activity in an institution in order to affirm medical professional and to

provide the opportunities of continuing medical education for healthcare staff' work, education, administration, and research. It would enhance healthcare staff's knowledge, techniques, and attitudes to cope with the rapidly changing healthcare environment (Hsu et al., 2015), achieve the professional standard and expectation, as well as reduce work adjustment and sleep quality caused by rapid changes of healthcare environment (Chiou et al., 2014). In this case, the following hypothesis is proposed in this study.

**H2:** Continuing medical education would influence sleep quality.

Chou and Hu (2015) pointed out the importance of nursing staff in the entire healthcare system. They had to directly face patients and learn responses to different situations; besides, patients appeared increasing request for nursing quality that stress was generated. Campion (2015) mentioned that nursing staff's perceived stress often came from work environment, the job, career & achievement, knowledge & skills, administrative management, and patients' conditions (Kivimäki et al., 2015). Nursing staff would perceive larger stress as they undertook most of the work to take care of patients and stressed on the importance of service and the responsibility for human life (Kang et al., 2014). Lin et al. (2015) mentioned that nursing staff's job stress to induce sleep disorder covered energy- and spirit-consuming shift, annoying cognition labor, and unstressed emotional labor, which were mainly caused by human allocation of hospitals. To control costs, hospital management tended to performance and profit orientation, but applied flexible and tight human resources so that nursing staff were induced sleep disturbance by job stress (Cheng et al., 2014). Accordingly, the following hypotheses are proposed in this study.

**H3:** Job stress presents significantly negative effects on sleeping time in sleep quality.

**H4:** Job stress shows remarkably negative effects on quality level in sleep quality.

## RESEARCH METHODOLOGY

### Measurement of Research Variable

#### *Job stress*

Referring to Cheng et al. (2014), job stress contains four dimensions of (1) personal response, (2) work concern, (3) work competency, and (4) private work.

#### *Sleep quality*

Referring to Chou and Hu (2015), (1) sleeping time and (2) quality level are covered.

### Research Subject and Sampling Data

To effectively achieve the research objective and test the research hypotheses, nonequivalent pretest posttest control group design is utilized for this study. Two hospitals in Hubei Province are studied; one is proceeded continuing medical education, while the other maintains the original state without continuing medical education for the half-a-year experiment. SPSS is used for analyzing the data in this study, and Factor Analysis, reliability analysis, Regression Analysis, and Analysis of Variance are applied to test various hypotheses.

### Analysis Method

Analysis of Variance is applied to discuss the difference of continuing medical education in job stress and sleep quality; furthermore, Regression Analysis is used for understanding the relationship between job stress and sleep quality.

## ANALYSIS RESULT

### Reliability and Validity Analysis

Job stress, with Factor Analysis, is extracted four factors of "personal response" (eigenvalue=2.762,  $\alpha$ =0.83), "work concern" (eigenvalue=2.215,  $\alpha$ =0.85), "work competency" (eigenvalue=1.946,  $\alpha$ =0.87), and "private work" (eigenvalue=1.757,  $\alpha$ =0.86). The cumulative covariance explained achieves 76.281%.

Sleep quality, with Factor Analysis, is extracted two factors of "sleeping time" (eigenvalue=4.638,  $\alpha$ =0.90) and "quality level" (eigenvalue=3.829,  $\alpha$ =0.89). The cumulative covariance explained reaches 85.774%.

**Table 1.** Analysis of Variance of continuing medical education toward job stress

	Variable	F	P	Scheffe post hoc
continuing medical education	personal response	7.63	0.000*	without education (3.98)>continuing medical education (3.25)
	work concern	11.25	0.000*	without education (4.51)>continuing medical education (3.16)
	work competency	13.17	0.000*	without education (4.69)>continuing medical education (3.27)
	private work	9.86	0.000*	without education (4.22)>continuing medical education (3.46)

\* stands for  $p < 0.05$ **Table 2.** Analysis of Variance of continuing medical education toward sleep quality

	Variable	F	P	Scheffe post hoc
continuing medical education	sleeping time	16.72	0.000*	continuing medical education (3.82)>without education (3.22)
	quality level	18.91	0.000*	continuing medical education (4.46)>without education (3.51)

\* stands for  $p < 0.05$ 

## Effects of Continuing Medical Education on Job Stress and Sleep Quality

### *Analysis of variance of continuing medical education towards job stress*

According to Analysis of Variance, the difference of continuing medical education in job stress is discussed. From **Table 1**, continuing medical education presents significant differences on personal response in job stress, where without continuing medical education (4.51) shows higher personal response than with continuing medical education (3.25). Continuing medical education reveals remarkable differences on work concern in job stress, where without continuing medical education (4.51) appears higher work concern than with continuing medical education (3.16). Continuing medical education presents notable differences on work competency in job stress, where without continuing medical education (4.69) shows higher work competency than with continuing medical education (3.27). Continuing medical education reveals remarkable differences on private work in job stress, where without continuing medical education (4.22) appears higher private work than with continuing medical education (3.46).

### *Analysis of variance of continuing medical education toward sleep quality*

Analysis of Variance is applied to discuss the difference of continuing medical education in sleep quality. From **Table 2**, continuing medical education presents notable difference on sleeping time in sleep quality, where with continuing medical education (3.82) presents higher sleeping time than without continuing medical education (3.22). Continuing medical education shows significant differences on quality level, where with continuing medical education (4.46) reveals higher quality level than without continuing medical education (3.51).

## Correlation Analysis of Job Stress and Sleep Quality

### *Correlation analysis of job stress and sleeping time*

To test H3, **Table 3**, personal response ( $\beta = -2.043^{**}$ ), work concern ( $\beta = -2.317^{**}$ ), work competency ( $\beta = -2.288^{**}$ ), and private work ( $\beta = -2.126^{**}$ ) reveal remarkably negative effects on sleeping time that H3 is supported.

### *Correlation analysis of job stress and quality level*

To test H4, **Table 3**, personal response ( $\beta = -2.096^{**}$ ), work concern ( $\beta = -2.372^{**}$ ), work competency ( $\beta = -2.293^{**}$ ), and private work ( $\beta = -2.187^{**}$ ) appear notably negative effects on quality level that H4 is supported.

**Table 3.** Analysis of job stress toward sleep quality

Dependent variable→	sleep quality			
	sleeping time		quality level	
Independent variable↓	$\beta$	Beta	$\beta$	Beta
job stress				
personal response	-2.043**	-0.194	-2.096**	-0.199
work concern	-2.317**	-0.223	-2.372**	-0.228
work competency	-2.288**	-0.215	-2.293**	-0.217
private work	-2.126**	-0.207	-2.187**	-0.210
F		26.83		33.29
significance		0.000***		0.000***
R2		0.276		0.347
Adjusted R2		0.243		0.311

Note: \* stands for  $p < 0.05$ , \*\* for  $p < 0.01$ .

Data source: Self-organized in this study

## CONCLUSION

The study reveals that continuing medical education could assist healthcare staff in promoting professional abilities to be competent of medical businesses, reducing physicians' job stress, and enhancing sleep and healthcare quality. Nevertheless, continuing medical education should not become a mere formality as healthcare staff is so busy that healthcare staff in remote areas is not easy to receive continuing medical education. Besides, the healthcare environment is getting complicated, patients is rising the rights awareness, and physicians are promoting the medical ethics that the course content, lecturer training, and course selection for continuing medical education should be comprehensively planned. Continuing medical education could help healthcare staff understand more about new knowledge of medicine in other fields, acquire new knowledge of medicine and synchronous information with medical centers, effectively reduce healthcare staff's job stress, enhance healthcare staff's practice capability, and promote the sleep quality. Under rising patients' rights and constantly enhancing convenience of network technology, it is also important to receive medicine ethics related regulations through continuing medical education. As a consequence, continuing education courses should be urgently practiced for healthcare staff.

## SUGGESTION

Aiming at above research results, the following suggestions are proposed in this study.

1. It is essential to practice continuing medical education system for enhancing healthcare staff's sleep and healthcare quality. However, healthcare staff is busy at work that online courses and medicine journals are suggested for practicing continuing medical education and reducing the difficulties for healthcare staff in remote areas. Moreover, courses for continuing medical education should be improved, e.g. opening real-time education of epidemic, publishing patents, increasing clinical courses, exchanging practical experiences, and holding on holidays, to reduce the time conflict of healthcare staff and balance the location.
2. Qualified teachers of continuing medical education should be established the database and requested the intention to conduct education plans. Teachers' practice should be reasonably evaluated, such as having the organizers fill in evaluation tables and opinions after the continuing medical education. The organizers could register and analyze such data to give proper feedback to the teachers. A national talent bank could be established, allowing suitable people to take charge in the continuing medical education courses, e.g. the establishment of bank, the cultivation of seed teachers, the storage of lecturers' list, and the emphasis on the professional attribute.
3. The time, location, contents, and places for continuing medical education should be taken into account for healthcare staff's suitability and convenience. It is important to create the participation incentive, rather than forcing healthcare staff to receive continuing medical education which does not benefit the medical work, with giving sign-in/sign-off or accumulated points for certificates. It should provide courses required for healthcare staff to develop the effectiveness of continuing medical education.

## REFERENCES

- Åkesson, A., Larsson, S. C., Discacciati, A., & Wolk, A. (2014). Low-risk diet and lifestyle habits in the primary prevention of myocardial infarction in men: a population-based prospective cohort study. *Journal of the American College of Cardiology*, 64(13), 1299-1306. <https://doi.org/10.1016/j.jacc.2014.06.1190>

- Ansoleaga, E. (2015). Psychosocial stress among health care workers. *Revista medica de Chile*, 143(1), 47-55. <https://doi.org/10.4067/S0034-98872015000100006>
- Campion, K. M. (2015). A survey of occupational skin disease in UK health care workers. *Occupational Medicine*, 65(1), 29-31. <https://doi.org/10.1093/occmed/kqu170>
- Cheng, Y., Du, C. L., Hwang, J. J., Chen, I. S., Chen, M. F., & Su, T. C. (2014). Working hours, sleep duration and the risk of acute coronary heart disease: a case-control study of middle-aged men in Taiwan. *International Journal of Cardiology*, 171(3), 419-422. <https://doi.org/10.1016/j.ijcard.2013.12.035>
- Chiou, S. J., Kung, P. T., Naessens, J. M., Huang, K. H., Chang, Y. C., Wang, Y. H., & Tsai, W. C. (2014). Do physicians with diabetes have differences in dialysis use and survival than other patients with diabetes. *Diabetes Research and Clinical Practice*, 105(3), 382-390. <https://doi.org/10.1016/j.diabres.2014.07.004>
- Chou, L. P., & Hu, S. C. (2015). Physician assistants in Taiwan. *Journal of the American Academy of Physician Assistants*, 28(3), 1-3. <https://doi.org/10.1097/01.JAA.0000460932.03971.e0>
- Chou, L. P., Li, C. Y., & Hu, S. C. (2014). Job stress and burnout in hospital employees: comparisons of different medical professions in a regional hospital in Taiwan. *BMJ open*, 4(2), e004185. <https://doi.org/10.1136/bmjopen-2013-004185>
- Davey, A., Sharma, P., Davey, S., Shukla, A., Srivastava, K., & Vyas, S. (2015). Are the adverse psychiatric outcomes reflection of occupational stress among nurses: An exploratory study. *Asian Journal of Medical Sciences*, 7(1), 96-100. <https://doi.org/10.3126/ajms.v7i1.12869>
- Go, A. S., Mozaffarian, D., Roger, V. L., Benjamin, E. J., Berry, J. D., Borden, W. B., ... Turner, M. B. (2013). Heart disease and stroke statistics--2013 update: a report from the American Heart Association. *Circulation*, 127(1), e6. <https://doi.org/10.1161/CIR.0b013e31828124ad>
- Hatherill, M., Scriba, T. J., Udawadia, Z. F., Mullerpattan, J. B., Hawkrigde, A., Mahomed, H., & Dye, C. (2016). BCG and New Preventive Tuberculosis Vaccines: Implications for Healthcare Workers. *Clinical Infectious Diseases*, 62(suppl 3), 262-267. <https://doi.org/10.1093/cid/ciw025>
- Heinen, M. M., van Achterberg, T., Schwendimann, R., Zander, B., Matthews, A., & Kózka, M., et al. (2013). Nurses' intention to leave their profession: a cross sectional observational study in 10 European countries. *International Journal of Nursing Studies*, 50(2), 174-184. <https://doi.org/10.1016/j.ijnurstu.2012.09.019>
- Hsu, Y. H., Kung, P. T., Wang, Y. H., Chang, Y. M., & Tsai, W. C. (2015). A comparison of the stages at which cancer is diagnosed in physicians and in the general population in Taiwan. *Canadian Medical Association Journal*, cmaj-141432. <https://doi.org/10.1503/cmaj.141432>
- Jeong, I., Rhie, J., Kim, I., Ryu, I., Jung, P. K., Park, Y. S., ... Won, J. U. (2013). Working hours and cardiovascular disease in Korean workers: a case-control study. *Journal of occupational health*, 55(5), 385-391. <https://doi.org/10.1539/joh.12-0245-OA>
- Johns, R. E., & Jepsen, D. M. (2015). Sources of occupational stress in NSW and ACT dentists. *Australian dental journal*, 60(2), 182-189. <https://doi.org/10.1111/adj.12323>
- Kang, M. Y., Cho, S. H., Yoo, M. S., Kim, T., & Hong, Y. C. (2014). Long working hours may increase risk of coronary heart disease. *American journal of Industrial Medicine*, 57(11), 1227-1234. <https://doi.org/10.1002/ajim.22367>
- Kivimäki, M., Singh-Manoux, A., Nyberg, S., & Batty, G. D. (2013). Job strain and coronary heart disease--Authors' reply. *The Lancet*, 381(9865), 448-449. [https://doi.org/10.1016/S0140-6736\(13\)60244-5](https://doi.org/10.1016/S0140-6736(13)60244-5)
- Kivimäki, M., Singh-Manoux, A., Nyberg, S., Jokela, M., & Virtanen, M. (2015). Job strain and risk of obesity: systematic review and meta-analysis of cohort studies. *International Journal of Obesity*, 39(11), 1597-1600. <https://doi.org/10.1038/ijo.2015.103>
- Lee, D. C., Pate, R. R., Lavie, C. J., Sui, X., Church, T. S., & Blair, S. N. (2014). Leisure-time running reduces all-cause and cardiovascular mortality risk. *Journal of the American College of Cardiology*, 64(5), 472-481. <https://doi.org/10.1016/j.jacc.2014.04.058>
- Lee, Y. S., Hsu, C. C., Weng, S. F., Lin, H. J., Wang, J. J., Su, S. B., ... Guo, H. R. (2015). Cancer Incidence in Physicians: A Taiwan National Population-based Cohort Study. *Medicine*, 94(47). <https://doi.org/10.1097/MD.0000000000002079>
- Lesuffleur, T., Chastang, J. F., Sandret, N., & Niedhammer, I. (2014). Psychosocial factors at work and sickness absence: results from the French National SUMER Survey. *American Journal of Industrial Medicine*, 57(6), 695-708. <https://doi.org/10.1002/ajim.22317>
- Lin, H. Y., Weng, S. F., Lin, H. J., Hsu, C. C., Wang, J. J., Su, S. B., ... Huang, C. C. (2015). Peptic Ulcer Disease in Healthcare Workers: A Nationwide Population-Based Cohort Study. *PLoS One*, 10(8), e0135456. <https://doi.org/10.1371/journal.pone.0135456>

- Michl, L. C., McLaughlin, K. A., Shepherd, K., & Nolen-Hoeksema, S. (2013). Rumination as a Mechanism Linking Stressful Life Events to Symptoms of Depression and Anxiety: Longitudinal Evidence in Early Adolescents and Adults. *J Abnorm Psychol*, 122(2), 339-352. <https://doi.org/10.1037/a0031994>
- Nyberg, S. T., Fransson, E. I., Heikkilä, K., Alfredsson, L., Casini, A., Clays, E., ... Kivimäki, M. (2013). Job strain and cardiovascular disease risk factors: meta-analysis of individual-participant data from 47,000 men and women. *PloS One*, 8(6), e67323. <https://doi.org/10.1371/journal.pone.0067323>
- O'Keefe, J. H., & Lavie, C. J. (2013). Run for your life... at a comfortable speed and not too far. *Heart*, 99(8), 516-519. <https://doi.org/10.1136/heartjnl-2012-302886>
- Pritchard, D. (2017). Hepatitis C: occupational exposure for healthcare workers. *Nursing*, 11, 54.
- Touré, A., Traoré, F. A., Sako, F. B., Delamou, A., Tonguino, F. S., Sylla, D., ... Vanhems, P. (2016). Knowledge, attitudes, and practices of health care workers on Ebola virus disease in Conakry, Guinea: a cross-sectional study. *Journal of Public Health and Epidemiology*, 8(2), 12-16. <https://doi.org/10.5897/JPHE2015.0752>
- Vijendren, A., Yung, M., & Sanchez, J. (2015). Occupational health issues amongst UK doctors: a literature review. *Occupational Medicine*, 65(7), 519-528. <https://doi.org/10.1093/occmed/kqv088>
- Walters, G. I., Moore, V. C., McGrath, E. E., Burge, P. S., & Henneberger, P. K. (2013). Agents and trends in health care workers' occupational asthma. *Occupational Medicine (Lond)*, 63(7), 513-516. <https://doi.org/10.1093/occmed/kqt093>
- Wong, N. D., Amsterdam, E. A., & Blumenthal, R. S. (2015). *ASPC Manual of Preventive Cardiology*. New York: Demos Medical Publishing.

<http://www.ejmste.com>



## Assessing the Impact of Technology Learning and Assessment Method on Academic Performance: Review Paper

Ragad M. Tawafak<sup>1,2\*</sup>, Awanis BT Romli<sup>1</sup>, Ruzaini bin Abdullah Arshah<sup>1</sup>, Rana A. Saeed Almaroof<sup>3</sup>

<sup>1</sup> Faculty of Computer Systems and Software Engineering, University Malaysia Pahang, 26300 Kuantan, Pahang, MALAYSIA

<sup>2</sup> Faculty of Information Technology Department, AlBuraimi University College, Buraimi, OMAN

<sup>3</sup> Faculty of English Language & Linguistics, AlBuraimi University College, Buraimi, OMAN

Received 9 November 2017 • Revised 26 February 2018 • Accepted 6 March 2018

### ABSTRACT

Technology enhancement learning is a process that leads to deep point of learning and adds knowledge of technologies. Various studies shed light on technology development and its effect in educational sector. The aim of this integrative review is to examine the current evidence of the impact of technology learning on student learning and academic performance in courses requiring collaborative or activities. The authors searched electronic databases for relevant articles, with different learning techniques. 24 articles met the requirement of paper, it's collected from (2011-2017). Three themes of techniques used for student learning outcomes, includes technology enhanced learning, assessment method and faculty experience on academic performance in universities with technology use. The final results of this paper show the relationship between what has been done and the factors used by the authors. Also the future work needs more use of technologies in different phases of learning process.

**Keywords:** Student Learning Outcome (SLO), Technology Enhancement Learning (TEL), Academic Performance (AP), Faculty Experience (FE)

### INTRODUCTION

An early look at historical development of educational institutions through different phases shows that these changes are closely linked to differences in each phase. Start with simple training in classical education to virtual education in that the educational system should reflect the educational needs of technology learning. Technology enhancement learning (TEL) applications are a new important area for study in high educational institutions. They are growing in popularity as a practice nowadays type of e-learning means to mediate, support active learning and authentic collaboration among students by web based technologies. They make a new mix between teachers and learners in responsibilities of learn and use technologies. This method will give flexibility to learner, use and read more with confidence of learning ways to be assessed by faculties (Benson, 2011; Wang & Hannafin, 2005). The learner knows the process phases include the mechanism of analysis, develop and evaluate. It divided to topic analysis, material used to develop, way of evaluating the outcomes, the techniques of delivering for assessment (Grover, Miller, Swearingen, & Wood, 2014). There are many types of applications used in technology learning. These applications may include, for example, video based programs, Wiki, and Google forms internet which are types of the Web 2.0 technology. These applications allow learners to interact with each other within a virtual learning environment rather than passively listen to an instructor. In addition collaborate in groups of Web page accessed via the internet, offering a space for users to add text, pictures, videos, online communications and links to other Web pages.

The technology triggers the learners to work in an unlimited time, peer assistance, teacher guidance, and team work students that trigger student learning and assessment as a learning outcome. These data tell the faculty and administrators what their students learn and achieve. This virtual connection improves student confidence and develops their knowledge skill and technology experience in a way to increase collaboration and results. TEL has

---

© 2018 by the authors; licensee Modestum Ltd., UK. This article is an open access article distributed under the terms and conditions of the Creative Commons Attribution License (<http://creativecommons.org/licenses/by/4.0/>).

✉ [raghad@buc.edu.om](mailto:raghad@buc.edu.om) (\*Correspondence) ✉ [awanis@ump.edu.om](mailto:awanis@ump.edu.om) ✉ [ruzaini@ump.edu.my](mailto:ruzaini@ump.edu.my)

✉ [rana@buc.edu.om](mailto:rana@buc.edu.om)

#### **Contribution of this paper to the literature**

- The effectiveness of technology enhanced learning on technology learning and the assessment method to improve the academic performance.
- This study discover the effect of teaching experience and technology learning development to be translated into positive student learning outcomes.
- The technology integrated tools emphasis on student interest in order to develop their academic performance.

increased the speed of transferring knowledge, also the method of transferring from faculty to students. The method is about learning and teaching thinking and methodologies within the context of outcome-based education in the learning environment.

The influence of technology on student learning can be viewed from clarifies how students learn, inquire, and reflect upon past experiences to build, refine and develop new knowledge of teaching and learning practices. In the early systems, students used traditional textbooks and normal exams to submit their performance and knowledge. Now a day, the students use different strategies employed by teachers and students in development of learning process. Using these applications (wiki or e-learning) tools is like an online conversation that gives opportunity to students to learn from other studies. The students can connect by internet with open discussion and with common groups under high experience of faculty's supervision, to create different discussion areas and develop different techniques with interest of use to improve their knowledge and scores with share perceptions on topics (Salajan & Mount, 2012).

Additionally, by the incorporation of technology, TEL might also be better able to meet the needs of the current generation of students and improve their activities, support and ability to learn while being surrounded by computers in their daily life (Lancaster, Wong, & Roberts, 2012).

In this step of assessment, the research focus on some important factors include first the student learning outcomes by e-learning to show the real outputs of universities, second the faculty qualification and experience of staff teaching faculties, third the assessment method used in TEL to prove the development. Essential learning outcomes mean condition of comprehension, expertises, thoughts, and occurrences of students in the followings aspects: civic commitment, thinker capability, communication and interpersonal relatives that need a lot of courses (Kleebua & Siriparp, 2016). The new technology learning is need for providing training courses to academic staff members at the universities in order to utilize eLearning in their courses, especially how to deal security and different learning material (Aldiab, Chowdhury, Kootsookos, & Alam, 2017). The use of TEL help to be better in research way for faculty and in self-assessment used to evaluate FE, students performance level, and course material evaluation by using these technological tools. These requirements need to be well observed and respected within academic regulations.

## **RESEARCH GOALS AND DESIGN**

The main objective of this study focus on there is a need to investigate whether TEL impacts on the SLO, assessment method, teaching and learning experience. This impact can measure through student academic performance that mean level of SLO and the way of assessment method used in education in a positive way in comparison to traditional learning. Also measure the faculty experience with TEL usage in development of teaching method impact on whole academic performance.

The secondary objectives were identified to achieve the main objective:

- To perform a literature review this will assist in identifying what TEL entails to improve academic performance
- To review current empirical research on the topic.
- To summarize conclusions based on the empirical results.

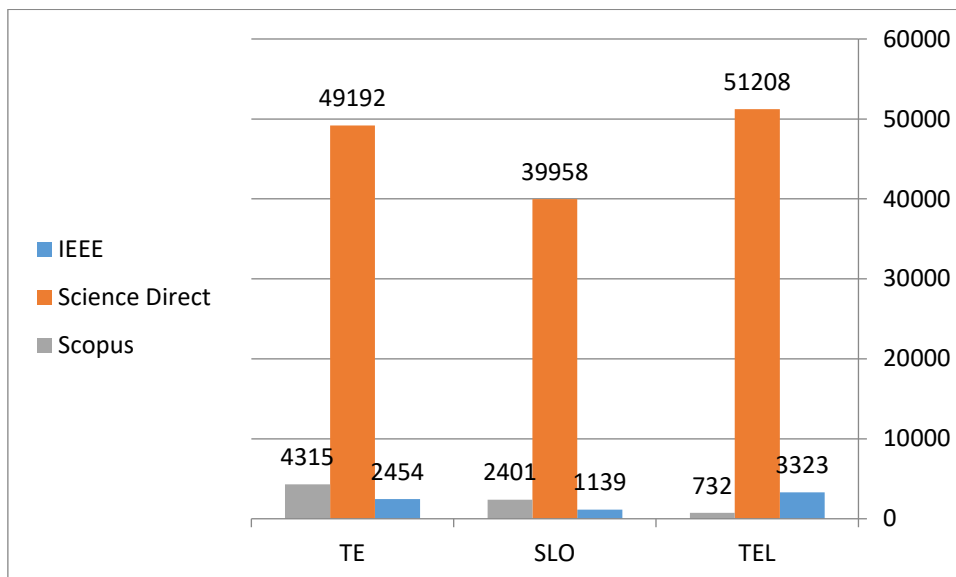
The students' experience in TEL environments varied according to the different educational levels of courses they took and services offered in their universities. In general, they used an "online learning management system (Moodle)", use of collaborative writing platforms (e.g. Google Docs), and used mobile devices (laptops) (Barak & Levenberg, 2016).

## **REVIEW METHODS INSTRUCTIONS**

This fragment includes an importance on teaching, experience, and assessment with TEL. The focus here, as a result, is on the organization and institutional systems for supervision the excellence of student knowledge by TEL,

**Table 1.** Database of searched articles

Database	TEL	SLO	TE	TOTAL
IEEE	3323	1139	2454	6916
Science Direct	51208	39958	49192	140358
Scopus	732	2401	4315	7448

**Figure 1.** The three databases for research articles results with main factors

and not on the specific programs themselves. These points include Student Learning Outcomes, Teaching Experience, and Technology Enhanced Learning, which fundamentally considered all criteria points as one complete set for accreditation process standard with academic issue.

Lin, Chen, and Liu (2017) indicated that the terms academic performance, learning outcome, or learning achievement expressed the same meaning of students' academic learning outcome. Learning outcome is an indicator to measure learners learning effect and support evaluation of teaching quality. SLO would be affected by assessment method, curriculum design, and teaching experience characteristics.

This paper focus on three major parts in search area and selected articles retrieved from database related to SSCI, and Scopus like downloaded of IEEE (6916), Science direct (140,358), Scopus (7448) with special keywords related to : teacher experience (TE), TEL, and SLO. The results of these key words give a lot of papers as shown in [Table 1](#) that based on the recent reviewing studies through 2011-2017 with different title majors. The major criteria for selecting these three factors based on standards of academic performance for accreditation process. There are many restricted papers removed because of dissertation, duplications in search, review papers, advertisement of university teaching method, teaching catalogs, university regulations and management issues, and papers based on techniques samples more than student performance. At the end the researchers selected only 24 papers as a sample to give an overview about the target of the three major factors.

The table above shows that science direct database has enormous number of articles that are related to the research object in [Figure 1](#). It gives the percentage of the highest present comes with more focus on the TEL, so this research gives chance to include the assessment method technology to work in parallel with the needed technology to enhance the development of the academic performance which is part of the learning process.

## LITERATURE REVIEW

The literature review of this paper sheds light on an integrative review of the literature to identify which standards, that can reflect best practice, are currently in use that focuses on different technologies. The total number of these papers is 24 which related to TEL techniques, with their effect on student learning outcomes, and faculty experience. The different technologies and applications used currently in the universities could directly or indirectly interfere with the graduation outcome and student achievements.

**Table 2.** Categories of moderator variables

Moderator variables	Categories in analyzed papers
Allocation	<ul style="list-style-type: none"> <li>• Pre-studies select different topics on students prefer, or college select neither groups of interest students with TEL</li> </ul>
Educational levels	<ul style="list-style-type: none"> <li>• Different studies in Secondary schools</li> <li>• Undergraduates (diploma, high- diploma, bachelor)</li> </ul>
Subject matter	<ul style="list-style-type: none"> <li>• Information technology</li> <li>• Business and Accounting</li> </ul>
Duration	<ul style="list-style-type: none"> <li>• Short courses in summer within 6-7 weeks</li> <li>• Long courses in semester within 17 weeks</li> </ul>
Communication	<ul style="list-style-type: none"> <li>• Face to face conversation</li> <li>• Online chat /Email message connection</li> </ul>
Quizzes	<ul style="list-style-type: none"> <li>• Traditional theoretical quizzes</li> <li>• Online exams/ electronic assessment</li> </ul>

**Table 3.** Categories of mediator variables

Type	Description
T	Used full tool programs (technology impact) using portal system in on-line course instead of traditional face to face learning. Used with far away distance in e-learning
TG	Use of tools with teacher guidance. It mixes between traditional teaching and e-learning on some programs to improve SLO and AMT though activates teamwork assignment assessment and increased student confidence of applied technology with course study.
ThW	Traditional work that only use class work and submitting hard copy exams and evaluations without use of new technology to enhance student skills.

### Three Key Challenges for Technology Enhancement Learning

This part presents the types of challenges that may face TEL in relation to three factors which affect the process of gaining AP and university accreditation. These challenges include the three elements of this study which are the development of student learning outcomes through assessment method, faculty experience, and faculty familiarity with technology which is based on enhanced learning tools. The TEL tools have to pass through four application-usages which are the Wiki chat- online conversation, Video programs, Audio-photo programs, and Google forms drive-applications. These are used for online evaluation to assist university outcomes.

The researchers of these studies state that the basic elements are related to one of the three options (T: used tool only, TG: used tool with teacher guidance, and ThW: used theoretical work only). Most of analyzed papers show the work moved toward theoretical work in assessment method more than toward of using tool in evaluation element. This result supports the aims that are suggested by the researcher of electronic support the major three key elements. These analyzed articles give identification to specific technology but still they do not show how it reflects positively on more than collaborative work between faculties, and how to develop student's skill to improve the comprehension level and interest in learning.

### The Moderator and Mediator Variables

The moderator variables used in this study are given in [Table 2](#). The table explains all the six variables of allocation, educational level, subject matter, duration, communication, and quizzes used in pre-analyzed studies where they measure student's academic performance at the end of this review paper. The analyzed papers show two different types of quizzes are used following the traditional way of assessment and online exams. Also the traditional face to face classroom conversation and the online communication between faculty and students, and student peer student are also considered as a means of communication. In [Table 3](#), it gives clarification on three techniques of teaching process are use.

From the two [Tables 2](#) and [3](#), it shows the previous studies consideration points and their major focus about type of services applied between two sides of the learners, teachers and the other side the location and level of e-learning used. But still a lot of studies did not give explanation and real achieved points on the assessment of learning used by teachers and how with TEL could produce high level of evaluation and moderation of all scores that affect in positive and beneficial results on student academic performance. From this gap the researchers of this paper comes to identify all types of services given and explain include factors, methodologies, and findings from 24 selected papers published in (2011-2017). Additional work it gives conclusions and suggestions to next type of TEL techniques used by faculties in assessment method that could help to increase the impact of academic performance.

## Technology Enhancement Difficulties

There are many restrictions that make it difficult to use the efficiency of technology tools or BL techniques in institutions and universities of HEI. It identifies the strength and weakness of giving market offer because they focused on service delivery more than outcomes. These types of application technologies are mostly used for business production to firstly increase the company income values, and secondly to improve the productivity of electronic use rather than relying on technology in developing knowledge skills of university performance (UP). In addition, develop the understanding of application tools, and experience with new generation of technologies. The updated technologies and applications are used currently in the universities, this usage may affect directly or indirectly the UP.

Another type of difficulty focuses on the time consumed in collecting evidence and in analyzing the data which could reflect the performance of manage in slow off the accreditation process (Pinedo, Chiyón, & Pérez, 2012). The educational levels and skills of students and administrator can be enhanced by using the supported the learning process (Graffigna, 2015). Also still the educator-student learning experience can't be replaced by technology due to human and social elements which technology lacks (Joseph, 2012). The experience of the expert faculties and administrative has a crucial role in improving UP and TEL. The answer to this difficulty is dealt with through the implementation of the experiential analysis within the application method in the higher education sector.

## RESULTS AND DISCUSSION

### The Quality of Student Achievement as Student Learning Outcomes using TEL

At this point of the study, the main focus is on SLO and student exams achievements. The educational courses answer the questions that are related to: a) How the students' shooting process have been carried out based on the uniqueness's standard and on the fundamental learning outcomes?, b) How the learners can accomplish the necessary learning outcomes by applying technology learning (Hashim & Majid, 2015). The student is the main part of the whole educational process and that there are many technologies involved such as an email; online videos, wiki chats, Google forms which can be viewed from different browsers and from different operating systems (Aldiab et al, 2017). When student used these technologies, his or her learning outcomes could be developed more. There are many studies concerned with student's achievements and many of them give good ideas and impression about how to improve the comprehension skills and attitudes, SLO and achievements. Most of these outcomes are evaluated through a computational model based on Web-based survey research as an important technique for behavioral research of some populations.

The implementation of well accomplishment with high quality in BL courses and study plan programs needs both planning and steps design. The mediums of learning identified are computer-based; video conferencing; satellite, webcast and CD-ROM. The education technology involves many learning types different from online communication, wiki chat, and different Google services (Joseph, 2012).

In online courses with most active application techniques allowed, or aid used technology course material, Students can access the open access courses; by using their email and passwords; submit their homework and projects through this system. Additionally, they are allowed to choose how they will access the necessary learning materials, and select the suitable group to join the sharing material (Yigit, Koyun, Yuksel, & Cankaya, 2014). Owing in TEL, the students have their opportunity to learn more and get benefits of education and be more confidence, more inspire to connect with others without need to face to face meeting and fixed time and schedule to learn.

The right implementation ensures the value of the learning outcomes assist the students' transition to fresh approaches in the field of training and learning. Sharing outcomes and education skilled from the newly transitioned blended program can suggest dating the future philosophy innovations and investigating (Posey & Pintz, 2016). The use of TEL helps to improve the SLO. They include reference to both self-assessment that is used to evaluate both faculty teaching method and students' performance, and course material evaluation based technological tools. These requirements need to be well observed and respected within the academic regulations.

In a study presented by Liu (2016), the researcher tries to use video BLOG to make an optimization for SLO in universities. He tries to make an investigation by using video class in face to face interaction that could enhance the university student learning performance and improve outcome. The method depends on emerging Web 2.0 application technology in supporting the process of teaching and SLO (De Wever, Hämäläinen, Voet, & Gielen, 2015). He employed an assessment technique to get the evidence for the actual student performance outcomes. This paper raises two questions which are as follows. The first question is that if the students can acquire the needed speaking skills using video blogging more effectively than who cannot make use of this advantage. The second question is that if they found this way more interesting in their communication with native speakers more than

their counterpart. The sample is experimented by self-selected or judgment. This result indicates that the use of video blog helps in improving students' learning outcomes.

Strang (2013), on the other hand, proposes a new idea which is concerned with asking instructors to form a kind of collaborative study group. The study helps in decreasing the gap between student low achievement and high-quality requirements. It's built on four significant predictors which are student's achievement, pedagogy, accumulated grade achieved and student gender. All these factors used in an arithmetic formula are applied by few faculties as integrated of knowledge concepts with the program. He used TEL to evaluate the efforts of faculty teaching could be approved through standardized exams during e-learning and enhanced learning through course runtime. The advantages of using new and updated computer technologies increase the SLO and AP, and allow students to more self-control of own their knowledge and type of learning to achieve learning goals (Laurillard, 2008). The generalized use of (TEL) could improve the online evaluation with high degree of satisfaction towards their grades and knowledge skills, especially when they are free to work any time without being limited in time.

In conclusion, the researchers in the tackled papers suggest strategies to develop a common framework for technology enhanced learning that is related to improve the knowledge skills required by the students, and academic performance. This in turn can help in facilitating the use updated technology to improve the whole learning process. The suggestion here is to get TEL advantages, and student can use their access authority to login and upload their assignments, quizzes, reports within duration time, without need to print hardcopy and fix real time to meet the faculty and discuss the document. In addition, students' course performance can be evaluated; students and the teachers can meet online and realize interactive learning activities. The point of using technology system is to increase the whole achievements of SLO that matching with accreditation to develop quality assurance strategies. The revision helps in keeping the balance factor and using the updated technology.

### **The Effect of TEL with University Outcomes and Teaching Experience & Quality**

Performance studies at the university level are highly dependent on the ways of how people build a sense of the rules, implement the balance sheet in their own organization and deal with policy contexts to get accreditation. The manager is also responsible for ensuring the University has a sufficient infrastructure to maintain productive and high quality delivery of both courses and programs (Aldiab et al., 2017). In education technology can enhance teaching and learning method if the center of attention is on education objectives and technology can be used as a possible technique. Many presented paper gave an understanding of expression education technology and how it affects on teaching and learning by highlighting its strengths and the challenges which slow down meaningful education experience for both teacher and learner (Joseph, 2012).

Naidu and Derani, (2016). This paper intends to compare between public and private universities to investigate their quality standards. The essential topic is related to students' satisfactions. The sample included the undergraduate students associated with tertiary education. The paper proposed that student requires the best of both quality and education. By using survey evaluation (SERVQUAL) universal method tool generate the results. The main focus is on the use of different technologies and applications in the current universities. This usage may affect directly or indirectly the university performance, targets of graduation outcomes and student achievements.

The education technology can lead to active learners who master their learning content and increases learner modes of critical thought ensuring students' growth at their own level, use most techniques of multimedia applications, video application, have greater collaboration skills and research skills (Joseph, 2012). In the main courses such as programming and analysis or hardware-based courses are taught face-to-face and the other courses are taught online. This type of teaching could improve the quality by highlights level of student satisfaction. Malik and Coldwell-Neilson (2016). They used an ADRI model in developing teaching method instead of traditional way of education. They came out with improving in students experience and develop in their achievements.

The investigation includes data that are related to programs and practices which are later linked with major and resultant education (Bourke, Ryan, & Lloyd, 2016). There is a multiplicity of innovative performances that have been developed to connect students. It is composed of "team-based learning, project-based learning, and community-based learning" (Michelson, Tong, & Reeves, May 2015). The TEL works just as well as traditional teacher learning, help in develop student confidence and skills

A newly proposed study by (Posey & Pintz, 2016) this can be implementing by new technology (T3) of teaching, transforming, and technology project. This blended method is used to develop the teaching goals, to identify the course challenges, and to increase the critical thinking and active learning. The main method is based on four components which are 1) the quality ratings solved by peer reviewing, 2) quality matters which are done by both preprogram and post program of digital literacy skills, 3) assessment of student satisfaction and 4) the interview with teachers to get feedback in the proposed format. The results revealed that the two suggested ways of teaching which are face to face interaction and the blended format are working in high interest result for improving quality.



Chmiel, Shaha, and Schneider (2017) improved a comprehensive evaluation framework for all actors. The study mostly focuses on students, teachers and institutional aspects of BL in higher educational institutions. The method is divided into three stages. The first stage is the Establishment of standards & concept of evaluation. The second stage has to do TEL with the tools of student, faculty, and administrator. The third stage is the implementation of the program on going evaluation. The finding shows that university policy tends to accept new method of teaching based on online classes and technology experience for both teachers, administrators.

The final suggestion of all previous studies is that all authors try to develop techniques that assist the educational functions including students, administrators, faculties, managers, directors depending on the portal system as a facilitator and specific technique tools (Apandi & Arshah, 2015). The researchers find that there is a gap as far as students' needs and faculty's needs. There are still uncovered points that are related to evaluation or assessment of student's results and mark distribution. Some of them, however, are explained in an effective manner. For individual work, or as team work evaluation. It is based on the use of hybrid technology in teaching which makes a comparison between traditional method of faculty teaching and the use of available e-learning library systems. The suggested techniques to develop the university outcomes could be checked by training of special experienced faculty staff can improve university accuracy. Therefore, it becomes HEI responsibility to make this requirement clearly available to prospective students.

### **The Effect of TEL with Assessment Method to Improve SLO**

The assessment method used in universities based on the traditional way of marking assignments of learners without clarify the rule of mark distribution. Also some studies give mark distribution and their relation with course objectives in traditional formal way. Less number of studies converts the TEL tools to be used in assessment method and show full teacher work on portal systems (Lin & Wu, 2016). One of the new article that is proposed by Wilby, Zolezzi, Rachid, and El-Kadi (2017) reviews a published and online literature showing how to develop a full assessment framework to do the same. The main method starts from appointing a coordinator of assessment by the dean. The appointment is carried out by a committee which consists of faculty, students and administrative. The committee will review papers and extract more key points to approve the accreditation strategy. Then data will be categorized into different majors depending on the review points. This categorization has different types of evaluation mechanisms. First, they work on curriculum development. Second, the gaps are identified within the program learning outcomes and summative assessments. Finally, the selected courses should support teachers in developing and improve the examinations and assignments. After the implementation the previously stated phases, it has been found out that the there is a need to include mission /vision, standards and the satisfaction of the students, faculty, and other stakeholders.

In the case of worldwide programs, the access standards are clarified by the distant student source.

As such, HEIs may need undergraduates to achieve higher standards. The analyzed papers, that handle AMT, still suffer from creating the right connection between teacher assessment and student assessment. This is due to the fact that there are no clear rules of single or group work of assessment. The objectives of the proposed work is to find the most appropriate technology work that can enhanced learning and to link them with other factors to develop the whole points as one set. These results may help in facilitating the university accreditation approval results.

**Table 4.** The analyzed papers based on factors affect related to TEL

Author	Experiment Studies	Moderator Variables	Method and Results
Bell & Youngs. (2011) Substance and show: Understanding responses to teacher education programme accreditation processes	Research use (k9-k12) high school to be tested of program	Influence of teacher assessment and way of teaching used, Implementation to be familiar with understand program, use interview to accreditation policy, Data collection & technology needs Classify factors (gender, teaching course, Role) by NCATE moved outcomes standards with HEI required to social, professional in Connecticut, teacher evaluation, generate new dataset.	In method construction, the accreditation process has two steps, the teacher education and NCATE standards. The program certified about 40 % per year new teachers while institution includes many parts (program size, financial part, institute size). The participant 89% (17of 19 members) like dean, senior faculty, new faculty joins the interview with varied questions. They agree with conceptual framework was positive with programmes and clear on collective values. The faculty creates new assessment way for accreditation requirement plus use of current assignments. Each institute has evidence of substantive and symbolic changes. This needs (rethinking, relearning, revision).
O'Bannon & Britt. (2011) Creating/developing/using a wiki study guide: Effects on student achievement	High school M=3.42 SD=0.569	The study exam the effectiveness of use wiki on teachers, the increase of knowledge, wiki frequency and communication habits. Experiment the effective, Wiki characteristics are unique, celebrative, simple, open editing, frequency of use include reader, writer, editor roles; and communication with increase teacher knowledge of Web 2.0, communication of wiki.	The framework use project based learning to put student in situation to solve real problems. Participant teachers (113), students (103) and 91% access the information, 5%0 need in secondary school, 13% for special needs. 77% female, 23% male in age of 23-24 out of normal population of 275. The procedure divided to group read, group use wiki videos, group used learn to know, then group to use project wiki. Two type of test pretest scenario, (t=29.186), p<0.001 and posttest definition (t=17.810). Finding are Wiki can increase student knowledge, but still less in posting or modifying, then using email is more, and in class conversation its most benefits to student skills.
Beleche, Fairris, & Marks, (2012) Do course evaluations truly reflect student learning? Evidence from an objectively graded post-test	1106 student, 33 teacher, 97 section measured used for M (4.34- 4.65) and SD (0.66- 0.95)	Match specific student learning records with specific course evaluation through fixed course and use individual students learning by high-stakes post-test to central of SLO, through online exams and technology of assessment.	Finding used t-test as numerical score to measure the exam by faculty electronic evaluation (Eval). The method use predetermine score that student should pass otherwise he have to remedial in freshman year. Many students can repeat it till pass to move for next academic year. Two phases of electronic and traditional evaluation used. The study use Eval, results shows 62% pass, 58% female, average of GPA=3.42. The empirical method use special equation to evaluate student performance, t-test give 0.00, 0.018 for lecture and posttest. Many factors and characteristics used with course learning, and subsequence of grade improvement with different M and SD and correlation coefficient. Robust positive, statistically significant, association of SLO & evaluate.
Abdullah, et al, (2012) Development of a Quality Assurance Plan in Line with UKM's Status as a Self-accreditation Institution and Research University	Undergraduate Un-weights values	Create a symbiosis and balance among the core processes for self- accreditation and Research project, academic program, services, & technology support to Improve quality by teaching, learning, & evaluating process in UKM.	The paper develop QA plan for academic program accreditation. It ensures the integration between education and research service to accreditation process. The audit identifies the procedure to check (vision, mission, curriculum development, assessment, etc.) this approved through determine create policies, documented processes, evaluation results, and continuous improvement. The self-accreditation status needs improving quality, teaching, and learning.
Joseph, J. (2012) The barriers of using education technology for optimizing the educational experience of learners	Undergraduate Un-weights values	Technology used teamwork with traditional teaching (teacher-student technology experience to improve their skills and knowledge) it impacted positively on the experience of the learner.	Quantitative study on the nature of technology based learning and how this practice contributes to teaching and learning. Finding shows that educators can't replace learning by TEL only. 80% shows good results, while 20% indicate It's not the best tool. While other studies give good use if used in educational technology experience. Total results 45% who used technology in problem solving. 42% used for experiments, 17% develop demonstrator, 13% for design product. Outcomes positive attitude by teacher and learner.
Schwartzbeck, & Wolf (2012) The Digital Learning Imperative: How Technology and Teaching Meet Today's Education Challenges	Undergraduate (N=100)	Technology creates personal learning, development, assessment, digital content, BL, online courses, tools and devises. Three major challenges facing the nation's education system access to good teaching, tight budgets, and boosting student achievement. This report outlines how digital learning can connect middle and high school students with better teaching and learning experiences.	Effective educational technology strategies must link the " Three Ts' teaching, technology, and use of time--with overall whole-school reform strategies. Method with technology can use 70% online and 30% F2F interaction in classroom (free time and location), and use of internet student be center and highly motivated with high efficiency. The results applied on traditional teaching and online teaching with same exam. Started by 32/49 participant in assignment 1, to 50/50 in final exam applied with BL. Conclusion show education was effective more than traditional, and student achievements was better.
Graham, et al,(2013) A framework for institutional adoption and implementation of blended learning in higher education	Un-weights results	How institutions working to increase student capacities to succeed in BL, online in three terms of Awareness, adoption, growth of BL. University policy to accept new method of teaching by online classes and technology experience for both teachers, administrator. In three levels of converting from F2F to BL.	The method move surrounding 6 institutions tested to adapt their policies. The general stages (setting, matching, restructuring, clarifying and routinizing). These institutions use different ways of BL and online learning. In UCF =53.401 students enrolled with undergraduate as high research. The framework use strategy, structure, support to implement BL. The analysis of data show teacher, student institute impact on BL and online courses. The results show most support to faculties rather than student. Where less work to increase student success in BL.
Strang, (2013) University accreditation and benchmarking: Pedagogy that increases student achievement	students last year of BSBA program ANOVA SE= 6.828	The stakes use of instructor to help students to increase their scores in standard exams	Quasi experiment designed to test standardized exam of samples (N-162), scores could be increased more than 3 grade points in collaborative study group based on SAT, GPA, Gender, pedagogy to balance student achievement. ANOVA regression model with 95% confidence capture 65% variance on exam, and high score above 3 is (Beta = 3.049). SPSS used for hypothesis test. The method fix professors, size, course syllabus, material and different time in two sections. Use 4 factors to find model applied by faculties to improve SLO using TEL improve low student score in collaborative group. GPA (b = .24, p < 0.01), gender (b = .18, p < 0.05), SAT/ACT score (b = .09, p < 0.01), and age (b = .03, p < 0.01), while ethnic culture was not significant. Population using z-tests (p < 0.05, one-tailed, N = 6150) MFTB score M= 150.97, SD = 11.52.

**Table 4 (continued).** The analyzed papers based on factors affect related to TEL

Author	Experiment Studies	Moderator Variables	Method and Results
Cavanagh, et al, (2014). The effect over time of a video-based reflection system on preservice teachers' oral presentations	High school N=47	Impression of communication acts (confidence, clarity, engagement, and appropriate). Interview (N=47). Constructed voice, body-language, words and alignment between language, grammar are communication with faculties by using video based program.	The method use recorded presentation on video and uploaded to web site and evaluated by peers of teachers to develop their performance. It should be positive teacher- student relationship to improve student learning. Significant improvement for all criteria. Universities have major responsibilities of development employees. While limitation on university program for learning and reflections on work place. Method use sequence of videos used for students, parents, and last class of semester, then receive feedback on (language, present style, voice, etc.). The results of overall test give in 4 rounds of times as (1 vs. 2) 21.15, p<0.001, (2 vs. 3) 6.70, (3 vs. 4) 0.06, and round 4= 41.50. The best result found in time 2, and less observation and reflection. This study good for beginner teachers in teaching and learning.
Crețu & Rogoz, (2014) Teachers' Expectations Regarding the Accredited Programs for Professional Development Provided by Universities	undergraduate N=618	Used collected data from universities to identify teacher expectation of development. The participant N=618 out of N=195 universities. The method used survey to develop evaluation reports, estimate the development area. IT cover three parts professional program, program level, and program population target.	The main objective is identifying teacher expectation on professional program, and the difference between teacher expectations. The results collected in SWOT analysis. The quantitative analysis collected by SPSS. The results systemized in 7 dimensions as study focus. 13 members involved in execution and 12 members participate in survey. Notice the noteworthy increase the training course related to education. The second study results shows perception reflected on teacher training. The policymaker encourages universities. Useful for interesting in updating accreditation professional development program.
Ozkan (2015) Wikis and blogs in foreign language learning from the perspectives of learners	undergraduate N=44+15	Observations of students' experimental practice presentation. Wiki program, forum, reaction, word attached to calculate students' perspectives of practice students' experimental presentation & skills Collaborative problem based activity. Wiki findings give them confidence and communication level.	Even wiki have discomfort between students, but this can reduced by increasing some activities were members are shuffled periodically. The finding show significant effect on language learning by using wiki and blog. The finding of Usefulness of wiki and blog as definitely agree are valid percent 52.3% and 38.6% respectively.
Adwan, (2016) Dynamic online peer evaluations to improve group assignments in nursing e-learning environment	N=279, Group31 M=4.54 SD=0.48	Evaluate individual and groups of assignments by online evaluation, activate, designed Google form, and peer evaluation form. Students will evaluate the presentation through peer evaluation and the faculty to improve their grades.	The method Use 3 types of color to inform student group of their evaluation results to improve POs of group learning Color code peer evaluation results after assignment that solve the low marks of online assignments. Results of entire sample M=4.54, SD=0.48, and low performance (N=31)M=3.64, SD=0.63
Al-Rahmi, & Zeki, (2016) A Model of Using Social Media for Collaborative Learning to enhance learners' Performance on learning	Postgraduate, undergraduates N=340 Many factors weighted	Use of social media internet items like Face book, Blogs, YouTube in celebrative work to enhance learner performance. There are significant relationship usefulness between social media use and celebrative learning.	The method work on Technology Acceptance Model (TAM), Pointed interaction between learner & instructors, also find the most adaptation on social media used that improve learner better performance. The objectives show there significant relationship between (usefulness and multimedia) (usefulness and collaborative work). The finding results analyzed by SEM to check validity and influence of factors. The AVE for each contrast more than 0.5. the hypothesis positive and significant (b =0.178, p <0.001), Cronbach's Alpha=0.908
Debicki et al (2016) Beyond the Big Five: The mediating role of goal orientation in the relationship between core self-evaluations and academic performance	undergraduates N=307 M=3.833 SD=0.563	Test core self-evaluation (of learner) on academic performance. Positive learning, prove performance Negative avoid performance by 3 test of self-evaluation. Use survey sample to measure individual's capabilities, worthiness on performance. Students themselves are good performance, success with Positive impact of core self-evaluation with AP.	Main works on High core self-evaluation is positively associated with both learning goal and prove performance goal. The results give M=3.833, SD=0.563. While academic performance gives M=82.08, SD=8.077. Learning goal orientation doesn't have significant result on the model. Limited in job performance, job satisfaction.
Lin, & Wu, (2016) Effects of Web-Based Creative Thinking Teaching on Students' Creativity and Learning Outcome	EG=93 CG=93	Web based era, faculties, and students. Teacher develops more creative teaching methods to teach students. Use of web-based era changed the media of creative thinking teaching. Applying design of experiment to the quasi-experimental research.	The method use quasi experiment on N=186 university students in Taiwan. The hypothesis of web based teaching positively affect creativity which affect learning outcomes. Results positively effect on creativity, learning outcomes and make up theoretical to web based creative thinking teaching.
Liu M., (2016) Blending a class video blog to optimize student learning outcomes in higher education.	undergraduate N=21+21 M=16.43 SD=3.99	Use of video class in face to face enhance the university student learning performance and improve outcome .No big difference between 2 experiments group (EG=21) and control group (CG=21) of learning willing.	The method use two sessions of 50 minutes in two weeks and teachers explain blog then given assignment that judgment by administrators. Investigation checks the using of video class in face to face could enhance the university student learning performance. Result shows positive join to Blog during learning process. The results Mean of average years of learning in both groups 9.2, 10.4. Mean of self-rated degree of English EG=2.67, CG=3.5. Final results EG's at the beginning of this study (Mean pre = 71.55 N 68.45) after engaging (Mean post = 100.67 N 92.14, F=30.910, p b .05, d=1.72). Outcomes show EG not significant increased.
Naidu, & Derani, (2016) A Comparative Study on Quality of Education Received by Students of Private Universities versus Public Universities.	N=50 M=(4.56- 2.18) SD=2.59-0.94	Improve university by student satisfaction technology as high priority. Used survey quality model (SERVQUAL), with TEL development, for student satisfaction and improve quality between public and private colleges. Use of reliable, secure tangible, responsibility.	The main works are how do you rate quality of services, and how do you rate quality of teachers in university. The results give (t=-8.08, P=0.001), (t=-7.16, P=0.001). Two types of results show private and public are significant satisfaction.

**Table 4 (continued).** The analyzed papers based on factors affect related to TEL

Author	Experiment Studies	Moderator Variables	Method and Results
Posey & Pintz, (2016) Transitioning a bachelor of science in nursing program to blended learning: Successes, challenges & outcomes	N=100, 54 flipped classroom, 44 collaborative M=4.22 SD=0.60	3 projects, includes 4 stages: quality of peer reviewer, pre and posttest of assessment, assessment on student BL and interview faculty perception by developing online exam.	The finding improves digital literature, improve independent activity. Sufficient in success of implementing BL. It uses 5 likert scales. Pre-test (M= 274.7, SD = 78.92) to post-test (M= 263.9, SD= 84.15). Finding gives online material are better than real reading.
Trocky & Buckley ,(2016) Evaluating the impact of wikis on student learning outcomes: an integrative review.	N=42 Many factors weights	Writing skills, collaboration, and knowledge acquisition centralized repository on SLO and co develop assignment. Effective tools in improving writing performance through create new ways to increase collaborative learning.	The method use quality rating by peer reviewer, pre-post assessment of students, student perception on BL experience, faculty interview. Two groups EG=42, CG=42. Wiki encourage students for more writing, reading, and grammar structure. Group for accuracy (F = 49.0, P = .000), quality (F = 66.7, P = .003), and total score (F = 122.7, P = .000). Mixed 4 factors to improve SLO & develop assignments, instruction aid students in learn knowledge. Limited with teaching learning strategies and evaluating SLO
Wu, & Tai, (2016) Effects of Multimedia Information Technology Integrated Multi-Sensory Instruction on Students' Learning Motivation and Outcome	N=92 Many factors weighted	The factors integrated instruction, students' learning motivation and interests. Teachers used multimedia to enhance SLO & encourage SL confidence. Teachers apply multimedia and information equipment to teaching activities. And encourage students to use multimedia for more confidence.	Learning motivation has significant correlation on LO. Multimedia information present remarkable on LO, and notable with learning motivation. LO of curriculum (B=2.342), learning environment (B=1.735), learning performance (B=2.163) P<0.05.
Yousif & Shaout, (2016) Fuzzy logic computational model for performance evaluation of Sudanese University , academic staff	undergraduate N=46	Consistency check, aggregation, approximate and final ranking to develop learning outcomes. 9 criteria tested in Sudan universities with 3 staff levels. Be consistence between universities using new fuzzy algorithm tool for experts.	The study present fuzzy logic computational model and use AHP and TOPSIS techniques. It design and compare through survey distributed on expert to measure academic staff performance. Returned questionnaire 66% of total 70 sent. Huge results compared between factors and questions in relation with each design path.
Lin, Chen, &Liu,2017) A Study of the Effects of Digital Learning on Learning Motivation and Learning Outcome	N=116 Many factors of weights	Design Teaching activity on digital learning and matching with teach technology tools, test such different digital learning, experience added to teachers. Digital material, digital tools, digital delivery to reduce time consume with digital learning.	Digital learning positively effect on learning motivation and reveal positively on learning outcomes (LO). Intrinsic and extrinsic of learning (0.202, 0.173) respectively. While leaning motivation positively effect on LO. Accepted teachers new teaching strategies, create digital learning lies on teachers, design a flexibility technology tools and more interactive with teachers.
Chmiel, Shaha, & Schneider, (2017) Introduction of blended learning in a master program: Developing an integrative mixed method evaluation framework	N=25 Many pointed weighted	Establish principles; evaluate BL, by 2 recurrence programs. Documented the power & weakness of BL, Work to increase capacities to succeed in BL & setting. Establish standards & concept of evaluation. Then tools related to student, faculty, and admin.	The method use multimodal evaluation to wrap up of different measures. Two factors checked in the study usability of tools 3.6 (s=0.5), quality of support 3.7. In addition improvement at program, faculty and educational level through evaluation of program proceed. Propose to develop mixed-method of monitoring BL, integrative work.
Wilby, et al, (2017) Development of a college-level assessment framework in line with international accreditation standards: A Middle Eastern perspective.	Un-weighted values	Step of accreditation standard. Programmatic assessment, academics, and satisfaction Create committee mix of factors to revise exams. The results measures 3 types of programmatic assessment, faculty and learner satisfaction on PLO and cumulative assessment.	Method use of committee of dean, faculty, student and administrator members grouped for assessment and quality they develop the framework and extract results. Results used comprehensive framework of 3 components and related assessment of mission, vision and standards. It conclude can coordinate assessment and support program.

## CONCLUSIONS

This study has reviewed 24 previous studies from (2011-2017) that have used TEL under three academic criteria of accreditation process which are the SLO, TEL, and FE. All of them work together to develop the use of online internet connection. From the viewpoint of viewing assessment and evaluation, it is supposed to clarify the relations of certain practices between faculty experience, evaluation of assessment and students achievements. On the other hand, of the standpoint, it is seen as a joint assessment effort performed by faculties of universities and institutes. Nevertheless, in educational claims the assessors' efforts install the idea of merge criteria's, it seems that the first conception strongly prevails.

The paper discuss the impact that TEL has on the teacher-student experience and does learning really takes place in educational process to improve SLOs. The analyzed studies demonstrated that three common techniques used mostly with these key elements (tool, tool with traditional guidance and traditional). These tool- techniques include online conversation specially (wiki programs) to keep link conversation with students, the video Blog programs to guide students for understanding material and the Google form drives that is used for all evaluation types in teaching, and assessment method. The technology development tools are aided to improve student skills and to facilitate interaction with their peers. TEL goals; creates meaningful feedback; identifies needs; modeling strategies; providing guided and independent practice; providing students with control of their learning (Schwartzbeck & Wolf, 2012).

**Table 5.** The effect of analyzed papers based on factors affect related to TEL

Author/year	Student Learning Outcomes			Assessment Method Techniques			Teaching Experience			University Performance			Participant	Impact On
	T	TG	ThW	T	TG	ThW	T	TG	ThW	T	TG	ThW		
Bell & Youngs, 2011			Y	Y					Y			Y	17	Teacher education program
O'Bannon, Britt 2011							Y	Y				Y	400	Student achievement
Abdullah, et al, 2012			Y				Y	Y				Y	None	Improve quality
Joseph 2012			Y				Y		Y			Y	None	Teacher-student experience
Schwartzbeck, & Wolf 2012			Y				Y	Y			Y		N=100	Teaching technology
Beleche, et al, (2012)	Y						Y			Y	Y		700+300	Student learning
Bell & Youngs, 2011			Y	Y					Y			Y	17	Teacher education program
O'Bannon, Britt 2011							Y	Y				Y	400	Student achievement
Abdullah, et al, 2012			Y				Y	Y				Y	None	Improve quality
Joseph 2012			Y				Y		Y			Y	None	Teacher-student experience
Schwartzbeck, & Wolf 2012			Y				Y	Y			Y		N=100	Teaching technology
Beleche, et al, (2012)	Y						Y			Y	Y		700+300	Student learning
Graham, et al, (2013)	Y						Y			Y		Y	None	Institution policy adapted
Strang (2013)			Y	Y					Y			Y	162	Increase student achievement
Cavanagh, et al, (2014)							Y			Y	Y		47	Pre-service teacher presentation
Crețu & Rogoz, (2014)							Y		Y			Y	618	Teacher expectation
Ozkan (2015)							Y			Y			59	Improve learner
Adwan, (2016)			Y					Y		Y			279	Student learning
Al-Rahmi, & Zeki, (2016)	Y						Y			Y	Y		340	Learner performance
Debicki et al (2016)							Y		Y			Y	307	self-evaluations and academic performance
Lin, & Wu, (2016)	Y						Y			Y		Y	186	Teaching on SLO
Liu M., (2016)	Y			Y						Y	Y		42	Optimize SLO
Naidu, Derani, (2016)			Y		Y			Y				Y	50	Teacher quality
Posey & Pintz, (2016)			Y							Y		Y	37	Nurse education
Trocky,Buckley (2016)			Y			Y	Y		Y		Y		42	SLO
Wu, & Tai, (2016)			Y			Y	Y					Y	92	SLO
Yousif, Shaout, (2016)			Y	Y					Y		Y		46	Staff performance
Lin, Chen, &Liu, (2017)			Y			Y			Y		Y		116	SLO
Chmiel, et al, (2017)						Y			Y				25	Evaluation accreditation
Wilby, et al, (2017)			Y			Y	Y				Y		None	Assessment quality

Where T: Tool only; TG: Tool with teacher guidance; and ThW: Theoretical work only; Y: Yes; Y: totally applied

As for the accreditation process, the link with the self-evaluators and UP are carried out by means of the technician, faculty, managers who eventually interested and experienced in technology. These technologies give level by level explanations or add values to student achievements and graduates outcomes. The referents from different academic programs implementation have confirmed that academic program assessments have consolidated essential practices. These practices have relation with other factors such as priorities in the technology of the particular projects. Therefore, the need for more studies that focuses on using TEL in assessment and teaching experience are required to develop the academic performance.

Based on the findings of analyzed papers technology was used in collaboration with traditional teaching it impacted positively on the education experience for all of the learner, faculty and university. The use of technology guarantees that students could work independently, increased communication and collaboration and have greater access to information with high confidence of assessment. Also, it shows the real need to develop the assessment method and it affection on SLO and academic performance of graduated students. This development confirms increase the trust and use of TEL in educational process.

## REFERENCES

- Abdullah, S., Wahab, D. A., & Hussein, S. M. (2012). Development of a Quality Assurance Plan in Line with UKM's Status as a Self-accreditation Institution and Research University. *Procedia-Social and Behavioral Sciences*, 59, 95-104. <https://doi.org/10.1016/j.sbspro.2012.09.251>
- Adwan, J. (2016). Dynamic online peer evaluations to improve group assignments in nursing e-learning environment. *Nurse education today*, 41, 67-72. <http://dx.doi.org/10.1016/j.nedt.2016.03.028>
- Aldiab, A., Chowdhury, H., Kootsookos, A., & Alam, F. (2017). Prospect of eLearning in Higher Education Sectors of Saudi Arabia: A Review. *Energy Procedia*, 110, 574-580. <https://doi.org/10.1016/j.egypro.2017.03.187>
- Al-Rahmi, W. M., & Zeki, A. M. (2016). A Model of Using Social Media for Collaborative Learning to enhance learners' Performance on learning. *Journal of King Saud University-Computer and Information Sciences*, 29(4), 526-535. <http://dx.doi.org/10.1016/j.jksuci.2016.09.002>
- Alshumaimeri, Y. (2011). The effects of wikis on foreign language students writing performance. *Procedia-Social and Behavioral Sciences*, 28, 755-763. <https://doi.org/10.1016/j.sbspro.2011.11.139>
- Apandi, S. H., & Arshah, R. A. (2015). The Need of Dashboard in Social Research Network Sites for Researchers. *International Journal of Software Engineering and Computer Systems*, 2(1), 120-132.
- Barak, M., & Levenberg, A. (2016). Flexible thinking in learning: An individual differences measure for learning in technology-enhanced environments. *Computers & Education*, 99, 39-52. <https://doi.org/10.1016/j.compedu.2016.04.003>
- Becher, M. (2013). Instruction coordinators and higher education accreditation: A study of awareness and assessment documentation use. *The Journal of Academic Librarianship*, 39(6), 573-581. <http://dx.doi.org/10.1016/j.acalib.2013.04.003>
- Beleche, T., Fairris, D., & Marks, M. (2012). Do course evaluations truly reflect student learning? Evidence from an objectively graded post-test. *Economics of Education Review*, 31, 709-719. <http://dx.doi.org/10.1016/j.econedurev.2012.05.001>
- Bell, C. A., & Youngs, P. (2011). Substance and show: Understanding responses to teacher education programme accreditation processes. *Teaching and teacher education*, 27(2), 298-307. <https://doi.org/10.1016/j.tate.2010.08.012>
- Benson, P. (2013). *Teaching and researching: Autonomy in language learning*. London: Routledge.
- Bourke, T., Ryan, M., & Lloyd, M. (2016). The discursive positioning of graduating teachers in accreditation of teacher education programs. *Teaching and Teacher Education*, 53, 1-9.
- Cavanagh, M., Bower, M., Moloney, R., & Sweller, N. (2014). The effect over time of a video-based reflection system on preservice teachers' oral presentations. *Australian Journal of Teacher Education (Online)*, 39(6), 1. <http://dx.doi.org/10.14221/ajte.2014v39n6.3>
- Chmiel, A. S., Shaha, M., & Schneider, D. K. (2017). Introduction of blended learning in a master program: Developing an integrative mixed method evaluation framework. *Nurse education today*, 48, 172-179. <http://dx.doi.org/10.1016/j.nedt.2016.10.008>
- Crețu, C. M., & Rogoz, N. (2014). Teachers' Expectations Regarding the Accredited Programs for Professional Development Provided by Universities. *Procedia-Social and Behavioral Sciences*, 142, 660-667. <https://doi.org/10.1016/j.sbspro.2014.07.682>
- Davis, S. W., Weed, D., & Forehand, J. W. (2015). Improving the nursing accreditation process. *Teaching and Learning in Nursing*, 10(1), 35-38. <https://doi.org/10.1016/j.teln.2014.09.003>
- De Wever, B., Hämäläinen, R., Voet, M., & Gielen, M. (2015). A wiki task for first-year university students: The effect of scripting students' collaboration. *The Internet and Higher Education*, 25, 37-44. <https://doi.org/10.1016/j.iheduc.2014.12.002>
- Debicki, B. J., Kellermanns, F. W., Barnett, T., Pearson, A. W., & Pearson, R. A. (2016). Beyond the Big Five: The mediating role of goal orientation in the relationship between core self-evaluations and academic performance. *The International Journal of Management Education*, 14(3), 273-285. <http://dx.doi.org/10.1016/j.ijme.2016.05.002>
- Graffigna, A. M. (2015). Effect of Institutional Evaluation Policies on Private Universities in the Cuyo Region. *Procedia-Social and Behavioral Sciences*, 197, 334-338. <https://doi.org/10.1016/j.sbspro.2015.07.146>
- Graffigna, A. M., Ghilardi, L., Fraca, C., de los Angeles Morell, M., Simonassi, M. L., Bartol, R., & Mengual, M. (2014). University Evaluation. From the Program's Accreditation to the Institutional Evaluation. *Procedia-Social and Behavioral Sciences*, 116, 2635-2639. <https://doi.org/10.1016/j.sbspro.2014.01.626>



- Graham, C. R., Woodfield, W., & Harrison, J. B. (2013). A framework for institutional adoption and implementation of blended learning in higher education. *The internet and higher education*, 18, 4-14. <http://dx.doi.org/10.1016/j.iheduc.2012.09.003>
- Grover, K. S., Miller, M. T., Swearingen, B., & Wood, N. (2014). An examination of the self-directed learning practices of ESL adult language learners. *Journal of Adult Education*, 43(2), 12.
- Hashim, A. A., & Majid, M. A. (2015). Effects of Video Display Terminal Resolutions to the Legibility of Text on a Web Page. *International Journal of Software Engineering and Computer Systems*, 1(1), 131-157. <http://dx.doi.org/10.15282/ijsecs.1.2015.11.0011>
- Heflin, H., Shewmaker, J., & Nguyen, J. (2017). Impact of mobile technology on student attitudes, engagement, and learning. *Computers & Education*, 107, 91-99. <https://doi.org/10.1016/j.compedu.2017.01.006>
- Joseph, J. (2012). The barriers of using education technology for optimizing the educational experience of learners. *Procedia-Social and Behavioral Sciences*, 64, 427-436. <https://doi.org/10.1016/j.sbspro.2012.11.051>
- Kleebua, C., & Siriparp, T. (2016). Effects of Education and Attitude on Essential Learning Outcomes. *Procedia-Social and Behavioral Sciences*, 217, 941-949. <https://doi.org/10.1016/j.sbspro.2016.02.061>
- Lancaster, J. W., Wong, A., & Roberts, S. J. (2012). 'Tech' versus 'Talk': A comparison study of two different lecture styles within a Master of Science nurse practitioner course. *Nurse education today*, 32(5), e14-e18. <https://doi.org/10.1016/j.nedt.2011.09.018>
- Laurillard, D. (2008). *Digital technologies and their role in achieving our ambitions for education*. Institute of Education, University of London.
- Lee, C., Yeung, A. S., & Ip, T. (2017). University English language learners' readiness to use computer technology for self-directed learning. *System*, 67, 99-110. <http://dx.doi.org/10.1016/j.system.2017.05.001>
- Lin, C. S., & Wu, R. Y. W. (2016). Effects of Web-Based Creative Thinking Teaching on Students' Creativity and Learning Outcome. *Eurasia Journal of Mathematics, Science & Technology Education*, 12(6), 1675-1684. <https://doi.org/10.12973/eurasia.2016.1558a>
- Lin, M. H., Chen, H. C., & Liu, K. S. (2017). A Study of the Effects of Digital Learning on Learning Motivation and Learning Outcome. *Eurasia Journal of Mathematics, Science and Technology Education*, 13(7), 3553-3564. <https://doi.org/10.12973/eurasia.2017.00744a>
- Liu, M. H. (2016). Blending a class video blog to optimize student learning outcomes in higher education. *The Internet and Higher Education*, 30, 44-53. <http://dx.doi.org/10.1016/j.iheduc.2016.03.001>
- Malik, S., & Coldwell-Neilson, J. (2016). Comparison of Traditional and ADRI Based Teaching Approaches in an Introductory Programming Course. *Journal of Information Technology Education: Research*, 16(1), 267-283.
- Michelson, D. G., Tong, W., & Reeves, L. (2015). Communications education and training: industry certification and university accreditation [Guest Editorial]. *IEEE Communications Magazine*, 53(5), 194-195.
- Naidu, P., & Derani, N. E. S. (2016). A Comparative Study on Quality of Education Received by Students of Private Universities versus Public Universities. *Procedia Economics and Finance*, 35, 659-666. [https://doi.org/10.1016/S2212-5671\(16\)00081-2](https://doi.org/10.1016/S2212-5671(16)00081-2)
- O'Bannon, B., & Britt, V. G. (2011). Creating/developing/using a wiki study guide: Effects on student achievement. *Journal of Research on Technology in Education*, 44(4), 293-312.
- Ozkan, M. (2015). Wikis and blogs in foreign language learning from the perspectives of learners. *Procedia-Social and Behavioral Sciences*, 192, 672-678. <https://doi.org/10.1016/j.sbspro.2015.06.102>
- Pinedo, M., Chiyón, I., & Pérez, F. (2012). The influence of transparency on self-evaluation as part of the university accreditation process in Peru. *Procedia-Social and Behavioral Sciences*, 46, 1069-1076. <https://doi.org/10.1016/j.sbspro.2012.05.250>
- Posey, L., & Pintz, C. (2017). Transitioning a bachelor of science in nursing program to blended learning: Successes, challenges & outcomes. *Nurse Education in Practice*, 26, 126-133. <http://dx.doi.org/10.1016/j.nepr.2016.10.006>
- Ralph, N., Birks, M., & Chapman, Y. (2015). The accreditation of nursing education in Australia. *Collegian*, 22(1), 3-7. <http://dx.doi.org/10.1016/j.colegn.2013.10.002>
- Salajan, F. D., & Mount, G. J. (2012). Leveraging the power of Web 2.0 tools: a Wiki platform as a multimedia teaching and learning environment in dental education. *Journal of dental education*, 76(4), 427-436.
- Schneider, C. G. (2016). Policy Priorities for Accreditation Put Quality College Learning at Risk. *Liberal Education*, 101(1).
- Schwartzbeck, T. D., & Wolf, M. A. (2012). The Digital Learning Imperative: How Technology and Teaching Meet Today's Education Challenges. Digital Learning Series. *Alliance for Excellent Education*.

- Strang, K. D. (2013). University accreditation and benchmarking: Pedagogy that increases student achievement. *International Journal of Educational Research*, 62, 210-219. <http://dx.doi.org/10.1016/j.ijer.2013.09.007>
- Trocky, N. M., & Buckley, K. M. (2016). Evaluating the impact of wikis on student learning outcomes: an integrative review. *Journal of professional nursing*, 32(5), 364-376. <http://dx.doi.org/10.1016/j.profnurs.2016.01.007>
- Wang, F., & Hannafin, M. J. (2005). Design-based research and technology-enhanced learning environments. *Educational technology research and development*, 53(4), 5-23. <http://www.jstor.org/stable/30221206>
- Wilby, K. J., Zolezzi, M., Rachid, O., & El-Kadi, A. (2017). Development of a college-level assessment framework in line with international accreditation standards: A Middle Eastern perspective. *Currents in Pharmacy Teaching and Learning*, 9(1), 115-120. <http://dx.doi.org/10.1016/j.cptl.2016.08.028>
- Wu, T. J., & Tai, Y. N. (2016). Effects of Multimedia Information Technology Integrated Multi-Sensory Instruction on Students' Learning Motivation and Outcome. *EURASIA Journal of Mathematics, Science & Technology Education*, 12(4), 1065-1074. <https://doi.org/10.12973/eurasia.2016.1552a>
- Yigit, T., Koyun, A., Yuksel, A. S., & Cankaya, I. A. (2014). Evaluation of blended learning approach in computer engineering education. *Procedia-Social and Behavioral Sciences*, 141, 807-812. <https://doi.org/10.1016/j.sbspro.2014.05.140>
- Yousif, M. K., & Shaout, A. (2016). Fuzzy logic computational model for performance evaluation of Sudanese Universities and academic staff. *Journal of King Saud University-Computer and Information Sciences*. <http://dx.doi.org/10.1016/j.jksuci.2016.08.002>

**<http://www.ejmste.com>**

# Applying Virtual Reality to Study the Effects of Environmental Education on College Students' Ethics and Environmental Literacy

Qiong Liu<sup>1</sup>, Dafeng Gong<sup>2</sup>, Min Chen<sup>3\*</sup>

<sup>1</sup> School of Marxism, Yangtze University, Jingzhou Hubei, CHINA

<sup>2</sup> Department of Information Technology, Wenzhou Vocational & Technical College, Wenzhou, CHINA

<sup>3</sup> Academy of Financial Research, Wenzhou University, Wenzhou, CHINA

Received 23 November 2017 • Revised 1 February 2018 • Accepted 2 March 2018

## ABSTRACT

Environmental risks and dilemmas in the global climate changes in past years have threatened human life. Scholars propose to reflect from the depth of human beings and establish the mutual ethic relationship between humans and natural environment to solve environmental problems. Various problems caused by the advance of technology could merely be solved by delivering correct value and natural ethics through education. Taking 360 students of Yangtze University, Hubei, as the research samples, the 32-week (3 hours per week) experimental research is preceded in this study. Among 360 distributed copies of questionnaire, 289 copies are valid, with the retrieval rate 80%. The research results show significant correlations between 1.environmental education and environmental ethics, 2.environmental ethics and environmental literacy, and 3.environmental education and environmental literacy. According to the results, suggestions are proposed, expecting to apply proper teaching methods to environmental education for smoother environmental education and effectively cultivating students' environmental ethics and environmental literacy.

**Keywords:** virtual reality, environmental education, environmental ethics, environmental literacy

## INTRODUCTION

Since Industrial Revolution, the establishment of factories, the invention of railways and automobiles, and the promotion of chemical products have made convenient and rich human life. Meanwhile, large amount of resources on the earth are consumed and the large use of fossil fuel enhances the emission of carbon dioxide to indirectly result in global climate changes and obvious global warming. Environmental changes, e.g. changing rainfall, increasing strength of storms, tornados, flood, and drought, and climate changes are threatening human health. People present infinite expectation on technologies and believe that the development of technology could change the world. However, humans' living quality and living environment are getting worse with changing technologies. In face of worsening environment and continuous ecological risks, people excessively depend on technologies to solve environmental problems, rather than dealing with ethic relationship between humans and the nature. New environmental problems are therefore emerged.

Environmental risks and dilemmas in past years are threatening human life. It is not the lack of technology knowledge, but not applying wisdom and destroying the world with technologies. Scholars therefore propose to reflect the depth of humans and establish the mutual ethic relationship between humans and the nature to solve environmental problems. Such problems caused by the advance of technologies could be changed by delivering correct value and natural ethics through education. It might become a negative measure, when the environment is damaged but not being compensated or discussing the roots of such environmental damages and survival risks of creatures. For this reason, people have to enhance the cognition and confirm personal belief to break through current environmental dilemmas and risks. Environmental ethics is essential for the world as it stands for the principles, value, belief, habits, and attitudes which humans are willing to obey for the environment as well as the

#### **Contribution of this paper to the literature**

- Team discussion and environmental experience sharing allow students effectively enhance the expression ability, benefit by mutual discussion, and integrate personal ideas to enhance personal environmental skills and environmental action experience.
- Education sectors are suggested to arrange time and locations for regular exchange or study, seminars, and action research of environmental education teachers in order to enhance the teaching profession.
- Schools could combine with community environment to enhance students' skills in investigating the living environmental problems and the intention and experience in participating in environmental education activities through community visits.

behavioral criteria for humans to follow. It shows that humans are responsible for maintaining global resources and respecting future generations. The process of education is long, but it could influence people's thoughts and value as well as change humans' lifestyles and attitudes towards the nature. The use of appropriate teaching methods for environmental education could achieve the learning effect and affect students developing correct environmental thinking attitudes and behaviors. Teachers applying proper teaching methods and available materials to enhance students' environmental ethics and environmental literacy could have smoother teaching and better teaching effect. In this case, virtual reality is applied in environmental education in this study to discuss the effect on college students' ethics and environmental literacy.

## **LITERATURE REVIEW**

### **Virtual Reality**

Morris (2014) explained virtual reality (VR) as to construct an environment with computer simulation and include real and virtual pictures in the simulated situation to make the situation present real pictures. The environment presented highly real interactive characters, allowing users viewing various pictures computed by the computer as well as operating the objects through human-computer interface. Users could freely move in the space to appear the senses of integration and participation and experience the environment. Baumgartner (2014) pointed out virtual reality as allowing users observing the simulated world from different angles and interacting with any objects in the virtual world. Virtual reality, a situated world constructed with computer scientific technology, transforms entities in the real environment and digital data into observable and even touchable 3D virtual scenes; matching with various human-computer interfaces, people become the direct participants in the virtual world, as in a real environment. Lederman, Antink, and Bartos (2014) regarded virtual reality as the combination of computers and the peripherals, allowing users being in the 3D space generated in the computer model. In the 3D virtual reality, the computer interaction is extended from the purely visual interaction to diverse interaction that users could interact with objects in virtual reality with sensory experiences and cognitive abilities as in the real world and browse the feeling close to the changes in the natural world. Chung, Yoo, Kim, Lee, and Zeidler (2014) described virtual reality as the best practice of situated teaching theory. The situations in virtual reality could provide users with a natural interface between the real world and the abstract logic, allowing users' cognition exceeding the knowledge in books and further developing self-concept and relationship.

### **Environmental Education**

Nazir and Pedretti (2015) explained environmental education as the process of cognitive value and concept clarification to develop, understand, and appreciate skills and attitudes essential for the mutual relationship among humans, culture and the creature, and physical environment. Environmental education was also applied to decision-making related to environmental quality and behavioral norms of self-orientation. Pai et al. (2014) regarded environmental education as an education process aiming at the correlation between people and the natural and artificial environment, including the problems related to human environment such as population, pollution, energy distribution and energy conservation, natural conservation, technology development, transportation construction, and urban and rural plans, allowing the citizens understanding the relationship between humans and environment through education. Ak and Kutlu (2015) pointed out environmental education as the lifelong learning process for people understanding the complicated natural world and the relevant issues. Based on the integration of knowledge in various fields, individual and social decisions made with various strategies had people present the attitudes and behaviors "to change the world". Focusing on school education, Lee et al. (2016) defined environmental education as educators concerning about the environment, including current or possible environmental problems in the education process, and containing environmental competence in the related course and teaching activity into the education design to effectively pass down to the next generation to

concern about the peripheral environment in daily life, protect the environment, do not damage the environment, actively participate in solving environmental problems, and present environment problem-solving competency to cope with difficult environment problems. Dymont et al. (2014) mentioned that environmental education was the process aiming to achieve the improvement, the education process to clarify concepts and form value, and the knowledge, skills, and attitudes required for human development and experiencing the mutual relationship among humans, culture & creature, and physical environment. Environmental education also taught people to make decisions and develop self-behavior principles when facing the issues related to environmental quality.

Referring to Cheng et al. (2015), environmental education contains three dimensions of environmental knowledge, environmental skills, and environmental attitudes in this study.

- (1) Environmental knowledge: To assist social groups and individuals in acquiring various experiences and basic understanding about the environment and the problems.
- (2) Environmental skills: To provide social groups and individuals with skills to identify and solve environment problems.
- (3) Environmental attitudes: To assist social groups and individuals in acquiring the value concerning about the environment and the promise to actively participate in environmental improvement and protection.

### **Environmental Ethics**

Ethics is the common value of the society that it could be revised or changed with changing society. Ethics sometimes might appear conflicts, but they are coexisted and integrated. There were human-environment coexisting philosophy and environmental ethics in past Chinese and western philosophy (Liddicoat & Krasny, 2014). Bearman et al. (2015) proposed that ethics was the morality existing between people and environmental ethics and the moral relationship between humans and natural environment, i.e. the ethic responsibilities of humans and natural environment. Ethics contained belief, attitudes, and value. Regarding the development of environmental ethics, Pai et al. (2017) mentioned that environmental ethics was the post-modern reflection after technological civilization, the new culture developing through self-center, culture or social center, different culture treatment, humanitarianism or human center to ecology center, and the globally consistent local reflection. Lindahl and Folkesson (2016) regarded human ethics as the product of evolution. For survival, mutual cooperation among humans was the result of natural selection. After humans' morality and ethics evolved from social ability, it would be expanded from family and neighbors to regions and nations through the promotion of culture (Frantz & Mayer, 2014). Environmental ethics referred to the moral relationship between humans and natural environment which could be used for controlling human behaviors towards natural environment (Van Uden, Ritzen, & Pieters, 2016).

Referring to Hsu and Wu (2016), environmental ethics in this study includes the following dimensions.

- (1) Human ethics: It is considered that human value is the center of the world, merely ethic principles are applied to humans, and human needs and profits present the highest value and importance.
- (2) Bioethics: All creatures present gifted value and are worth of respect.
- (3) Eco-ethics: The close relationship between humans and the nature is perceived, and humans without conforming to the rules in the natural ecology would be in ecological risks.

### **Environmental Literacy**

Ko et al. (2016) pointed out environmental literacy as an observable behavior that an individual was willing to and capable of making decisions to be responsible for the environment, generating the behavior to balance life and environmental quality, and concerning about the environment and beloved people, affairs, and objects (Zorrilla-Pujana & Rossi, 2014). Biasutti (2015) contained the perception and appreciation of natural environment and artificial environment, the knowledge of natural systems and ecological concepts, the understanding of current environmental issues, and even the environmental problem-solving by applying investigation, critical thinking, writing, and communication abilities in environmental literacy. Environmental literacy in ecology dictionary referred to the knowledge of natural systems and ecological concepts, the understanding of environmental issues, and the environmental problem-solving with investigation, thinking, and communication (Liu & Lin, 2014). Hall and Allan (2014) pointed out environmental literacy as individual knowledge and attitudes related to the environment and environmental issue, skills and motivation to solve environmental problems, and willingness to maintain the dynamic balance between life quality and environmental quality. Rashid and Asghar (2016) proposed that environmental literacy should focus on responsible environmental behaviors and environmental education should teach students, before the changes of behaviors, about ecology concepts related to environment and the implied mutual relationship among environments. Environmental literacy was the ability to sense and explain the health of environmental systems and the action to maintain, recover, or enhance the health of environment systems (Pai et al., 2015).

Referring to Chen and Pai (2015), environmental literacy in this study covers the following dimensions.

- (1) Environmental sensitivity: The perception of distinct environmental damage and pollution as well as the appreciation of and sensitivity to natural environment and artificial environment.
- (2) Action experience: The environmental protection behaviors taken in daily life and the actual participation in environmental protection activities.

### **Research Hypothesis**

Ak and Kutlu (2015) indicated that the final goal of environmental education was to create responsible attitudes and develop environmental ethics, which agreed that human world was not a material world but a value world; and, the morality of environmental education was to have the citizens comprehend and comment such value (Vainio & Paloniemi, 2014). Lee et al. (2016) argued that environmental education was to develop individual morality and ethics through education process. Hsieh (2014) pointed out the cultivation of environmental ethics as the ideal of environmental education. Dymont et al. (2014) pointed out the teaching of environmental ethics and the emphasis on the cultivation of students' positive environmental attitudes as the differences between environmental education and other subjects. Shephard et al. (2014) pointed out the key in practicing environmental education as to establish correct environmental ethics that teachers should reinforce the cultivation of environmental ethics, which was the key success factor in environmental education. Cheng et al. (2015) regarded the final goal of environmental education as the cultivation of active environmental ethics. Environmental ethics could also be called environmental morality, which was people's behavioral norms and principles (Liddicoat & Krasny, 2014). Accordingly, the following hypothesis is proposed in this study.

**H1:** Environmental education reveals notable correlations with environmental ethics.

Yahaya, Zain, and Karpudewan (2015) indicated that environmental education activities could induce students' perception of and sensitivity to environment, enhance the knowledge related to environmental sustainability, provide students with correct environmental ethics about the interaction between people and environment, and present the cognition and skills to improve or solve environmental problems when facing regional or global environmental issues to establish learners' environmental action experience and to become the citizens with environmental literacy. Rivers, Wickramasekera, Pekala, and Rivers (2016) mentioned to cultivate students' positive environmental ethics through the teaching and emphasis on environmental education so that students could appreciate the nature and the operation system, enhance the environmental literacy, appreciate and accept different culture, concern about disadvantaged groups, and further concern about the survival and development of future generation. Hsu and Wu (2016) proposed that environmental education could be applied to cultivate the citizens' environmental ethics, enhance the knowledge, attitudes, skills, and value to protect the environment, promote the environmental literacy, enhance the emphasis on environment, and take actions to achieve the sustainable development (Van Uden et al., 2016). The following hypothesis is therefore proposed in this study.

**H2:** Environmental ethics presents significant correlations with environmental literacy.

Ko et al. (2016) regarded the final goal of environmental education as to cultivate the citizens with environmental literacy. Sellmann (2014) indicated that the promotion of environmental literacy relied on the promotion and practice of environmental education, which was the responsible perception, when facing the environment, to cultivate the positive environmental attitudes, actively participate in environmental protection actions, and enhance environmental literacy through the concept of natural ecology conservation and the environmental justice. Rashid and Asghar (2016) proposed to develop the function of environmental education through educational goal and teaching methods, inspire humans' perception of and sensitivity to environment, enrich environmental protection concepts, practice environmental protection actions, and cultivate environmental ethics and value. Those were covered in the promotion of literacy and the solution for environmental threats. Tung and Pai (2015) considered the relationship between environmental literacy and environmental education that environmental literacy was the goal of environmental education, while environmental education was the process of people acquiring environmental literacy. Environmental literacy should be the development process, rather than the end; environmental literacy was the continuity of knowledge, skills, attitudes, and mental habits. Although the level of literacy was not pure and definite, it appeared the order of educational function (Pai et al., 2015). In this case, the following hypothesis is proposed in this study.

**H3:** Environmental education shows remarkable correlations with environmental literacy.



## METHOD AND SAMPLE

### Research Object

Total 360 students of Yangtze University, Hubei, are proceeded 32-week experiment, 3 hours per week, in this study. Total 289 valid copies of questionnaire are retrieved, with the retrieval rate 80%. Located in Jingzhou City, Hubei Province, Yangtze University is a comprehensive university with the largest scale and complete subjects in Hubei Province. It is the backbone university in the key construction projects in Hubei Province, is the “double fist-class” university domestically, is the selected university in “National Basic Ability Construction Project of Western and Central China”, and is the trial university of Excellent Engineer Education Cultivation Program, Excellence in Agriculture and Forestry Talent Training Program, and Excellent Doctor Education and Training Program of Ministry of Education. Moreover, it is co-constructed by Hubei Provincial People’s Government, China National Petroleum Corporation, Sinopec, the China Petroleum and Chemical Corporation, and China National Offshore Oil Corporation as well as the university co-constructed by Hubei Provincial People’s Government and Ministry of Agriculture.

### Analysis

Regression Analysis is applied to understand the relationship among students’ environmental education, environmental ethics, and environmental literacy.

## ANALYSIS RESULT

### Operational Definition and Measurement of Variable

#### *Environmental education*

Environmental education contains environmental knowledge, environmental skills, and environmental attitudes, and the overall reliability coefficients appear environmental knowledge 0.85, environmental skills 0.81, and environmental attitudes 0.87.

#### *Environmental ethics*

Environmental ethics includes human ethics, bioethics, and eco-ethics, and the overall reliability coefficients show human ethics 0.82, bioethics 0.84, and eco-ethics 0.89.

#### *Environmental literacy*

Environmental literacy covers environmental sensitivity and action experience, and the overall reliability coefficients reveal environmental sensitivity 0.90 and action experience 0.88.

### Regression Analysis of Environmental Education and Environmental Ethics

Regression Analysis is utilized for testing the hypotheses and the theoretical structure. The first regression tests the effect of environmental education on human ethics. The results reveal positive effects of environmental knowledge, environmental skills, and environmental attitudes on human ethics (Beta=0.231,  $p=0.023$ ; Beta=0.242,  $p=0.011$ ; Beta=0.283,  $p=0.000$ ). The second regression tests the effect of environmental education on bioethics. The results show positive and significant effects of environmental knowledge, environmental skills, and environmental attitudes on bioethics (Beta=0.248,  $p=0.006$ ; Beta=0.266,  $p=0.000$ ; Beta=0.294,  $p=0.000$ ). The third regression tests the effect of environmental education on eco-ethics. The results present positive and remarkable effects of environmental knowledge, environmental skills, and environmental attitudes on eco-ethics (Beta=0.271,  $p=0.000$ ; Beta=0.287,  $p=0.000$ ; Beta=0.302,  $p=0.008$ ) (Table 1). Accordingly, H1 is supported.

**Table 1.** Regression Analysis of environmental education towards environmental ethics

Dependent variable Independent variable	Environmental ethics					
	Human ethics		Bioethics		Eco-ethics	
environmental education	Beta	P	Beta	P	Beta	P
environmental knowledge	0.231	0.023	0.248	0.006	0.271	0.000
environmental skills	0.242	0.011	0.266	0.000	0.287	0.000
environmental attitudes	0.283	0.000	0.294	0.000	0.302	0.000
F	21.736		27.815		33.627	
R <sup>2</sup>	0.225		0.291		0.328	
adjusted R <sup>2</sup>	0.193		0.264		0.293	

\*p<0.05 \*\*p<0.01

Data source: Self-organized in this study

**Table 2.** Regression Analysis of environmental ethics towards environmental literacy

Dependent variable Independent variable	Environmental literacy			
	Environmental sensitivity		Action experience	
environmental ethics	Beta	P	Beta	P
human ethics	0.288	0.000	0.269	0.000
bioethics	0.297	0.000	0.274	0.000
eco-ethics	0.311	0.000	0.283	0.000
F	25.412		31.637	
R <sup>2</sup>	0.272		0.294	
adjusted R <sup>2</sup>	0.245		0.268	

\*p<0.05 \*\*p<0.01

Data source: Self-organized in this study

### Regression Analysis of Environmental Ethics and Environmental Literacy

Regression Analysis is used for testing the hypotheses and the theoretical structure in this study. The first regression tests the effect of environmental ethics on environmental sensitivity, where human ethics, bioethics, and eco-ethics show positive effects on environmental sensitivity (Beta=0.288, p=0.000; Beta=0.297, p=0.000; Beta=0.311, p=0.000). The second regression tests the effect of environmental ethics on action experience, where human ethics, bioethics, and eco-ethics appear positive and notable effects on action experience (Beta=0.269, p=0.000; Beta=0.274, p=0.000; Beta=0.283, p=0.000) (Table 2). H2 is therefore supported.

### Regression Analysis of Environmental Education and Environmental Literacy

Applying Regression Analysis to test the hypotheses and the theoretical structure, the first regression tests the effect of environmental education on environmental sensitivity, in which environmental knowledge, environmental skills, and environmental attitudes present positive effects on environmental sensitivity (Beta=0.291, p=0.000; Beta=0.303, p=0.000; Beta=0.334, p=0.000). The second regression tests the effect of environmental education on action experience, in which environmental knowledge, environmental skills, and environmental attitudes appear positive and significant effects on action experience (Beta=0.286, p=0.000; Beta=0.314, p=0.000; Beta=0.343, p=0.000) (Table 3). Accordingly, H3 is supported.

**Table 3.** Regression Analysis of environmental education towards environmental literacy

Dependent variable Independent variable	Environmental literacy			
	Environmental sensitivity		Action experience	
environmental education	Beta	P	Beta	P
environmental knowledge	0.291	0.000	0.286	0.000
environmental skills	0.303	0.000	0.314	0.000
environmental attitudes	0.334	0.000	0.343	0.000
F	32.588		36.192	
R <sup>2</sup>	0.304		0.354	
adjusted R <sup>2</sup>	0.285		0.331	
*p<0.05 **p<0.01				

Data source: Self-organized in this study

## CONCLUSION

From the research results, virtual reality experience and operation courses could more easily induce students' interests, deepen the learning image, and promote the environmental ethics and environmental action experience. In addition to achieving the cognitive goal, more importantly, the practice of environmental education could achieve the goal of environmental ethics cultivation, allowing students practicing environmental skills in the virtual reality experience and cultivating action experience, as well as teaching students to study environmental problems and evaluating possible solutions. Apparently, the application of virtual reality to the practice of environmental education presents certain effect. Teachers therefore could combine the support of virtual reality related resources for more opportunities to apply virtual reality to students' exploration and experience in environmental education, select locations or issues in which students are interested, design course activities matching with environmental characteristics, seek people with professional knowledge for interpreting the environment, as well as expand students' learning vision and contact with the nature so as to promote the effect of environmental education.

## SUGGESTION

By concluding the results and findings, the following practical suggestions are proposed in this section.

1. Team discussion and environmental experience sharing allow students effectively enhance the expression ability, benefit by mutual discussion, and integrate personal ideas to enhance personal environmental skills and environmental action experience. Parents matching with and assisting in school courses could have students cultivate good environmental ethics and environmental literacy to achieve the effect of environmental education.
2. Education sectors are suggested to arrange time and locations for regular exchange or study, seminars, and action research of environmental education teachers in order to enhance the teaching profession. Moreover, teachers could share the teaching experience in environmental education and mutually observe and discuss lessons to improve the environmental education teaching skills, prepare lessons together, and present self-development.
3. Students' learning styles should be understood in order to design the best environmental education programs combined with the learning styles, cultivate students' environmental ethics, and further improve the explicit environmental literacy. It is also suggested that schools could combine with community environment to enhance students' skills in investigating the living environmental problems and the intention and experience in participating in environmental education activities through community visits. What is more, environmental education sectors should more actively make plans to encourage students' environmental action experience, attract students actively participating in environmental action, effectively cultivate students' environmental ethics, and promote students' environmental literacy.

## ACKNOWLEDGEMENTS

Research on the soft power construction of hubei province under the perspective of historical materialism (project no. 17Q060) of Hubei Provincial Department of Education.

## REFERENCES

- Ak, O., & Kutlu, B. (2015). Comparing 2D and 3D game-based learning environments in terms of learning gains and student perceptions. *British Journal of Educational Technology*, 48(1), 129-144. <https://doi.org/10.1111/bjet.12346>
- Baumgartner, C. (2014). *Environmental Education in Protected Areas along the Danube – Report of the Assessment Tour*. Brussels, Belgium: European Union.
- Bearman, M., Palermo, C., Allen, L. M., & Williams, B. (2015). Learning empathy through simulation: a systematic literature review. *Simulation in Healthcare*, 10(5), 308-319. <https://doi.org/10.1097/SIH.0000000000000113>
- Biasutti, M. (2015). An intensive programme on education for sustainable development: the participants' experience. *Environmental Education Research*, 21(5), 734-752. <https://doi.org/10.1080/13504622.2014.921805>
- Chen, L., & Pai, T. Y. (2015). Comparisons of GM (1, 1), and BPNN for predicting hourly particulate matter in Dali area of Taichung City, Taiwan. *Atmospheric Pollution Research*, 6, 572-580. <https://doi.org/10.5094/APR.2015.064>
- Cheng, M. T., She, H. C., & Annetta, L. A. (2015). Game immersion experience: its hierarchical structure and impact on game-based science learning. *Journal of Computer Assisted Learning*, 31(3), 232-253. <https://doi.org/10.1111/jcal.12066>
- Chung, Y., Yoo, J., Kim, S., Lee, H., & Zeidler, D. L. (2014). Enhancing students' communication skills in the science classroom through socioscientific issues. *International Journal of Science and Mathematics Education*, 14(1), 1-27. <https://doi.org/10.1007/s10763-014-9557-6>
- Dyment, J. E., Davis, J. M., Nailon, D., Emery, S., Getenet, S., McCrea, N., & Hill, A. (2014). The impact of professional development on early childhood educators' confidence, understanding and knowledge of education for sustainability. *Environmental Education Research*, 20(5), 660-679. <https://doi.org/10.1080/13504622.2013.833591>
- Frantz, C. M., & Mayer, F. S. (2014). The importance of connection to nature in assessing environmental education programs. *Evaluating Environmental Education*, 41, 85-89. <https://doi.org/10.1016/j.stueduc.2013.10.001>
- Hall, C., & Allan, F. (2014). Influencing Carbon Behaviours: What Psychological and Demographic Factors Contribute to Individual Differences in Home Energy Use Reduction and Transportation Mode Decisions? *Energy and Environment Research*, 4(1), 1-15. <https://doi.org/10.5539/eer.v4n1p1>
- Hsieh, T. L. (2014). Motivation matters? The relationship among different types of learning motivation, engagement behaviors and learning outcomes of undergraduate students in Taiwan. *Higher Education*, 68(3), 417-433. <https://doi.org/10.1007/s10734-014-9720-6>
- Hsu, Y. S., & Wu, H. K. (2016). Development and evaluation of technology-infused learning environments in Taiwan. In M. H. Chiu (Ed.). *Science education research and practices in Taiwan: Challenges and opportunities* (pp.211-232). New York: Springer. [https://doi.org/10.1007/978-981-287-472-6\\_11](https://doi.org/10.1007/978-981-287-472-6_11)
- Ko, J. W., Park, S., Yu, H. S., Kim, S. J., & Kim, D. M. (2016). The structural relationship between student engagement and learning outcomes in Korea. *Asia-pacific Education Researcher*, 25(1), 147-157. <https://doi.org/10.1007/s40299-015-0245-2>
- Lederman, N. G., Antink, A., & Bartos, S. (2014). Nature of science, scientific inquiry, and socio-scientific issues arising from genetics: A pathway to developing a scientifically literate citizenry. *Science & Education*, 23, 285-302. <https://doi.org/10.1007/s11191-012-9503-3>
- Lee, C. S., Hayes, K. N., Seitz, J. C., DiStefano, R., & O'Connor, D. (2016). Examining motivational structures that differentially predict engagement and achievement in middle school science. *International Journal of Science Education*, 38(2), 192-215. <https://doi.org/10.1080/09500693.2015.1136452>
- Liddicoat, K. R., & Krasny, M. E. (2014). Memories as Useful Outcomes of Residential Outdoor Environmental Education. *The Journal of Environmental Education*, 45(3), 178-193. <https://doi.org/10.1080/00958964.2014.905431>
- Lindahl, M. G., & Folkesson, A. M. (2016). Attitudes and language use in group discussions on socio-scientific issues. *Science & Technology Education*, 12(2), 283-301.
- Liu, S.-C., & Lin, H. (2014). Undergraduate students' ideas about nature and human-nature relationships: an empirical analysis of environmental worldviews. *Environmental Education Research*, 20(3), 412-429. <https://doi.org/10.1080/13504622.2013.816266>
- Morris, H. (2014). Socioscientific issues and multidisciplinary in school science textbooks. *International Journal of Science Education*, 36(7), 1137-1158. <https://doi.org/10.1080/09500693.2013.848493>

- Nazir, J., & Pedretti, E. (2015). Educators' perceptions of bringing students to environmental consciousness through engaging outdoor experiences. *Environmental Education Research*, 22(2), 288-304. <https://doi.org/10.1080/13504622.2014.996208>
- Pai, T. Y., Lo, H. M., Wan, T. J., Chen, L., Hung, P. S., Lo, H. H., Lai, W. J., & Lee, H. Y. (2015). Predicting air pollutant emissions from a medical incinerator using grey model and neural network. *Applied Mathematical Modelling*, 39(5-6), 1513-1525. <https://doi.org/10.1016/j.apm.2014.09.017>
- Pai, T. Y., Lo, H. M., Wan, T. J., Wang, S. C., Yang, P. Y., & Huang, Y. T. (2014). Behaviors of biomass and kinetic parameter for nitrifying species in A2O process at different sludge retention time. *Applied Biochemistry and Biotechnology*, 174(8), 2875-2885. <https://doi.org/10.1007/s12010-014-1233-3>
- Pai, T. Y., Wang, S. C., Lo, H. M., Chen, L., Wan, T. J., Lin, M. R., Lin, C. Y., Yang, P. Y., Lai, W. J., Wang, Y. H., & Lu, T. H. (2017). A simulation of sewer biodeterioration by analysis of different components with a model approach. *International Biodeterioration & Biodegradation*, 125, 37-44. <https://doi.org/10.1016/j.ibiod.2017.08.003>
- Rashid, T., & Asghar, H. M. (2016). Technology use, self-directed Learning, student engagement and academic performance: Examining the interrelations. *Computers in Human Behavior*, 63, 604-612. <https://doi.org/10.1016/j.chb.2016.05.084>
- Rivers, A., Wickramasekera, I. E., Pekala, R. J., & Rivers, J. A. (2016). Empathic Features and Absorption in Fantasy Role-Playing. *American Journal of Clinical Hypnosis*, 58(3), 286-294. <https://doi.org/10.1080/00029157.2015.1103696>
- Sellmann, D. (2014). Environmental education on climate change in a botanical garden: Adolescents' knowledge, attitudes and conceptions. *Environmental Education Research*, 20(2), 286-287. <https://doi.org/10.1080/13504622.2013.870130>
- Shephard, K., Harraway, J., Lovelock, B., Skeaff, S., Slooten, L., Strack, M., ... Jowett, T. (2014). Is the environmental literacy of university students measurable? *Environmental Education Research*, 20(4), 476-495. <https://doi.org/10.1080/13504622.2013.816268>
- Tung, Y. T., & Pai, T. Y. (2015). Water management for agriculture, energy and social security in Taiwan. *CLEAN-Soil Air Water*, 43(5), 627-632. <https://doi.org/10.1002/clen.201300275>
- Vainio, A., & Paloniemi, R. (2014). The complex role of attitudes toward science in pro-environmental consumption in the Nordic countries. *Ecological Economics*, 108, 18-27. <https://doi.org/10.1016/j.ecolecon.2014.09.026>
- Van Uden, J. M., Ritzen, H., & Pieters, J. M. (2016). Enhancing student engagement in pre-vocational and vocational education: A learning history. *Teachers and Teaching*, 22(8), 983-999. <https://doi.org/10.1080/13540602.2016.1200545>
- Yahaya, J. M., Zain, A. N. M., & Karpudewan, M. (2015). The effects of socio-scientific instruction on pre-service teachers' sense of efficacy for learning and teaching controversial family health issues. *International Journal of Science and Mathematics Education*, 13(2), 467-491. <https://doi.org/10.1007/s10763-014-9537-x>
- Zorrilla-Pujana, J., & Rossi, S. (2014). Integrating environmental education in marine protected areas management in Colombia. *Ocean & Coastal Management*, 93, 67-75. <https://doi.org/10.1016/j.ocecoaman.2014.03.006>

<http://www.ejmste.com>



For print copies of this issue or articles please send an e-mail to:

[print@modestum.co.uk](mailto:print@modestum.co.uk)



# Why do Plants Wilt? Investigating Students' Understanding of Water Balance in Plants with External Representations at the Macroscopic and Submicroscopic Levels

Gregor Torkar <sup>1</sup>, Manja Veldin <sup>2</sup>, Saša Aleksej Glažar <sup>1</sup>, Anja Podlesek <sup>3\*</sup>

<sup>1</sup> University of Ljubljana, Faculty of Education, Department of Biology, Chemistry and Home Economics, Ljubljana, SLOVENIA

<sup>2</sup> The Educational Research Institute, Ljubljana, SLOVENIA

<sup>3</sup> University of Ljubljana, Faculty of Arts, Department of Psychology, Ljubljana, SLOVENIA

Received 20 December 2017 • Revised 7 February 2018 • Accepted 8 February 2018

## ABSTRACT

In order to understand water balance in plants, students must understand the relation between external representations at the macroscopic, microscopic, and submicroscopic levels. This study investigated how Slovenian students ( $N = 79$ ) at the primary, secondary, and undergraduate tertiary levels understand water balance in plants. The science problem consisted of a text describing the setting, visualizations of the process occurring in a wilted plant stem, and five tasks. To determine students' visual attention to the various elements of the tasks, we used eye tracking and focused on the total fixation duration in particular areas of interest. As expected, primary school students showed less knowledge and understanding of the process than the secondary school and university students did. Students with correct answers spent less time observing the biological phenomena displayed at the macroscopic and submicroscopic levels than those with incorrect answers, and more often provided responses that combined the macro-, micro-, and submicroscopic levels of thought. Learning about difficult scientific topics, such as the water balance in plants, with representations at the macroscopic and submicroscopic levels can be either helpful or confusing for learners, depending on their expertise in using multiple external representations, which is important to consider in biology and science education.

**Keywords:** biology, eye tracking, multiple representations, osmosis, students

## INTRODUCTION

In order to understand basic biology concepts, it is important for students to develop an understanding of the transport of materials across cell membranes. Learning about the mechanisms underlying water balance in plant cells is dependent on understanding osmosis and diffusion (Malińska, Rybska, Sobieszczuk-Nowicka, & Adamiec, 2016). Diffusion is the primary method of short-distance transport in cells and cellular systems. It is defined as the random, thermal movement of molecules in which a net flow of matter moves along a concentration gradient, i.e., from an area of higher concentration toward an area of lower concentration (Sperelakis, 2012). Osmosis is used to explain water uptake by plants, turgor pressure in plants, water balance in aquatic creatures, and transport in living organisms. It is the flow of a solvent across a semipermeable membrane from a region of lower to higher solute concentration (Sperelakis, 2012).

Johnstone and Mahmoud (1980) published a very influential study about the learning difficulties encountered by Scottish secondary school students and university students in biology. Two of the most troublesome topics proved to be genetics and water transport in plants. Problems concerning water transport may result from the fact that this topic is related to the processes of diffusion and osmosis (Malińska et al., 2016). Several studies (AlHarbi, Treagust, Chandrasegaran, & Won, 2015; Malińska et al., 2016; Odom, 1995; Odom & Barrow, 1995; Odom & Kelly,

© 2018 by the authors; licensee Modestum Ltd., UK. This article is an open access article distributed under the terms and conditions of the Creative Commons Attribution License (<http://creativecommons.org/licenses/by/4.0/>).

✉ [gregor.torkar@pef.uni-lj.si](mailto:gregor.torkar@pef.uni-lj.si) ✉ [manja.veldin@pei.si](mailto:manja.veldin@pei.si) ✉ [sasa.glazar@guest.arnes.si](mailto:sasa.glazar@guest.arnes.si)

✉ [anja.podlesek@ff.uni-lj.si](mailto:anja.podlesek@ff.uni-lj.si) (\*Correspondence)

#### Contribution of this paper to the literature

- Students with correct answers spent less time observing the biological phenomena displayed at the macroscopic and submicroscopic levels and they more often provided responses that combined macro-, micro-, and submicroscopic levels of thought.
- When responding to the task correctly, primary school students mostly provided answers at the macroscopic level, but when their explanations included micro- or submicroscopic levels of thought the percentage of incorrect answers increased substantially.
- The study provides evidence that students regularly use the microscopic or “cell level” of thought to explain complex biological phenomena.

2001; Sanger, Brecheisen, & Hynek, 2001; She, 2004; Tomažič & Vidic, 2012; Zuckerman, 1988) reported that students have many difficulties understanding diffusion and osmosis processes. According to these studies, difficulties with understanding diffusion and osmosis are the result of 1) confusion regarding vernacular and scientific usage of terms such as pressure, concentration, and quantity; 2) misunderstanding technical concepts such as solution, semipermeability, and molecular and net movement; and 3) insufficient abilities in terms of formal reasoning, visualization, and thinking at the molecular (or submicroscopic) level.

Panizzon (2003) wrote that one step toward a better understanding of diffusion and osmosis would be to provide students with a range of learning opportunities that would enable them to gain different experiences to explore and build their understanding of diffusion and osmosis. Tomažič and Vidic (2012) found that pre-service teachers that had actively approached the concepts of (e.g., conducted experiments on) diffusion and osmosis in upper secondary school achieved significantly higher scores on a diffusion and osmosis diagnostic test. AlHarbi et al. (2015) found that pre-service teachers' understanding of osmosis and diffusion concepts was mildly positively correlated with their understanding of particle theory. The findings suggest that greater time and attention need to be invested in teaching particle theory for students to ensure their scientific understanding of diffusion and osmosis. Sanger et al. (2001) demonstrated that students that observed computer animations depicting the molecular processes when perfume particles diffuse in air and when water osmoses through a semi-permeable membrane developed more accurate conceptions of these processes based on particulate nature and random motion of matter.

Teaching diffusion and osmosis should not be limited to acquiring decontextualized and unrelated facts (Odom, 1995), or to learning these concepts for their own sake (Hasni, Roy, & Dumais, 2016). To build understanding, students should be able to link new concepts with those that are already familiar to them (Marek, Cowan, & Cavallo, 1994). In the case at hand, students need to link biology processes such as water uptake by plants and turgor pressure in plants with diffusion and osmosis. Furthermore, Tomažič and Vidic (2012) made the important conclusion that observation alone at a macroscopic level of processes explained by diffusion and osmosis is not sufficient, and that a link must be made to also understand it at the submicroscopic level.

Johnstone (1991) argued that understanding of science concepts can be explained with triple levels of representations: the macroscopic, submicroscopic, and symbolic level. Taking his model into account, to understand turgor pressure in plants properly the learner should consider the macroscopic level at which biological structures are visible to the naked eye, the submicroscopic level at which the interactions between particles are shown, and the symbolic level that uses symbols, formulas, chemical equations, etc., to explain the mechanism of the phenomenon. However, Tsui and Treagust (2013) claimed that in biology four levels of representations should be considered instead of three. Due to the hierarchical organization of biological entities (e.g., cells are nested within tissues, these are nested within organs, etc.), another level of representation should be added, i.e. the microscopic level at which structures are only visible under a microscope.

According to Ainsworth (1999), translation refers to learning situations in which a student must comprehend a relation between external representations at different levels: for example, understanding turgor pressure in plants at the macroscopic level (e.g., a photo of a plant), microscopic level (e.g., a microscopic image of plant cell), and the submicroscopic level (e.g., animations of molecules and particles). Treagust and Tsui (2013) claimed that learning biology with multiple external representations enables constructing deeper understanding in terms of scientific reasoning.

Ainsworth (2008) argued that multiple representations are powerful tools, but need careful handling if learners are to use them successfully. She made the following recommendations on how to use multiple representations to support the acquisition of complex scientific knowledge. First, the minimum number of representations that are required for a learner to understand should be used. Secondly, the skills and experience with particular type of external representation (e.g., diagram, graph, equation) of the intended learners should be assessed. Thirdly, the representations should be sequenced to gradually introduce a concept, allowing learners to gain knowledge and confidence with fewer representations before introducing more. Next, it should be considered what extra support

is needed for learners to overcome all the cognitive tasks related to learning with multiple representations (e.g., exercises, consistent colours, labels and symbols). And finally, it should be considered what pedagogical functions external representations have. For example, if the primary goal is to support complementary functions, then it may be sufficient that the learners understand representations individually, without understanding the relations between them. On the other hand, when the learners must understand the connections between representations, it is imperative that we find ways of signaling how to connect representations (e.g., we can use arrows).

Different methods can be used for studying students' processing of multiple representations of biological concepts. Besides examining verbal responses and achievements or using think-aloud protocols, eye tracking technology can also be used. Eye tracking makes it possible to monitor cognitive processes due to the links between eye movements and cognition (Rayner, 1998). Eye movements indicate where attention is being directed. The duration of a fixation is associated with the ongoing mental processes related to the fixated information (Henderson, 2007; Just & Carpenter, 1976). Total fixation time (i.e., cumulative duration of fixations within a region) is considered as a sign of the amount of total cognitive processing engaged with the fixated information (Just & Carpenter, 1980; Rayner, 1998).

Eye movement data can provide information about the cognitive processes of the learner (Ballard, Hayhoe, Pook, & Rao, 1997; Just & Carpenter, 1976), such as reading, language processing, scene perception, and visual search, and other information processing tasks (Rayner, 1998, 2009). Eye tracking has been used in many studies of learning and problem solving (for a review see, for example, Lai et al., 2013), and is as well a promising method for studying students' processing of various visualizations (Ferk Savec, Hrast, Devetak, & Torkar, 2016; Hinze et al., 2013; Stieff, Hegarty, & Deslongchamps, 2011). Using eye tracking, Chen et al. (2014) found that pictorial presentations appear to convey physics concepts more quickly and efficiently than do textual presentations. Hannus and Hyönä (1999) found that during learning authentic textbook materials high-ability students paid more attention to pertinent segments of an illustration than did low-ability students. In a study by Lin, Holmquist, Miyoshi, and Ashida (2017), detailed illustrations with salient features (colour and greater detail) received more of students' visual focus than simplified illustrations and seemed to better motivate students for learning, which led to the conclusion that the use of detailed illustrations may be beneficial in the early learning stage, as far as they do not introduce excessive distracting details.

Eye tracking measures were shown to differentiate between novices and experts (Tai, Loehr, & Brigham, 2006), high- and low-ability students (Hannus & Hyönä, 1999), and successful and unsuccessful problem solvers (Hegarty, Meier, & Monk, 1995). In a meta-analysis on expertise differences in the comprehension of visualizations, Gegenfurtner, Lehtinen, and Säljö (2011) concluded that experts have shorter fixation durations, more fixations on task-relevant areas and fewer fixations on task-redundant areas than novices.

Based on the above mentioned studies it is reasonable to expect that eye movement data can also provide important information about students' understanding of diffusion and osmosis and can be helpful in investigating processing of multiple representations of these concepts in students with different expertise. We found two studies that addressed this issue using eye tracking technology. Cook, Carter, and Wiebe (2008) examined how high school students' prior knowledge of diffusion and osmosis influenced the way they observed and interpreted a static visual representation of cellular transport processes. They found that students with high prior knowledge oriented their visual attention to conceptually relevant features, whereas students with low prior knowledge focused more on surface features of the graphics. Cook, Wiebe, and Carter (2008) presented students a graphic containing three macroscopic representations of the diffusion process and three corresponding submicroscopic (molecular) representations. They found that high prior knowledge students transitioned more frequently between the submicroscopic representations, whereas low prior knowledge students transitioned more frequently between the macroscopic ones.

## Aims and Research Questions

The aim of our study was to extend the work done by Cook, Wiebe, and Carter (2008) on the differences in the learners' distribution of visual attention when interpreting multiple representations. We wanted to study more closely how students at various educational levels (primary, secondary, and undergraduate tertiary) understand water balance in plants and the process of osmosis. In particular, we explored which thought levels (i.e., the macroscopic, microscopic, submicroscopic, and symbolic levels; Johnstone, 1991; Tsui & Treagust, 2013) students use in their explanations of turgor pressure in plants, whether they are capable of comprehending the relation between external representations at different levels, and how they transition between different levels of representations and shape their responses when asked to explain what exactly is going on during the biological process that causes plant wilting. A dynamic animation was used to present the submicroscopic level of the process instead of static images. To gain a better insight into students' cognition while solving a task on osmosis, eye-tracking measures (fixation times) were combined with behavioural measures (response time, accuracy, and content).

With education, students' understanding of biological concepts develops from naïve to expert. In our study, the following research questions were defined:

1. How are the differences between the groups of students at different levels of education in their knowledge and understanding of the water balance in plants reflected in the way they are solving an authentic biological problem? Which thought levels do students at different levels of education use to explain water balance in plants? Do they link different thought levels and how?
2. What are the differences between students that solved the tasks about water balance in plants correctly and those that did not in the time they spent observing biological phenomenon displayed at the macroscopic and submicroscopic levels?

## METHODS


### Participants

Slovenian primary school students ( $n = 30$ ), secondary school students ( $n = 29$ ), and pre-service teachers ( $n = 20$ ) participated in the study. Primary school students (age 12 or 13) were attending the seventh grade of public primary school in Ljubljana. Secondary school students (age 15 to 17) were attending the first year of secondary school in Ljubljana. Pre-service teachers (age 22 to 25) were in their fourth year at the University of Ljubljana's Faculty of Education, working on a degree in two science subject areas (double-subject teacher of biology and chemistry) leading first to the bachelor's degree (a 4-year program) and compulsory continuation at the master's level (a 1-year program).

### The Science Problem

The selected science problem was presented on a computer screen in a form of a text describing the setting, visualizations of the process occurring in a wilted plant stem, and five tasks on two PowerPoint slides. Both slides contained the same photo of a wilted plant stem of grape hyacinth (*Muscari botryoides*). On both PowerPoint slides there were also three dynamic animations specially made for the purpose of this study. Two out of three animations incorrectly displayed turgor pressure in a plant cell. Animations included a submicroscopic level with particles representing the process of osmosis. The upper part of the display contained an introductory text, explaining what is presented in the photo and represented in the animations. Separate from the introductory text, the tasks were presented (**Figure 1**). On Slide 1, the task was to describe why the plant had wilted (Task 1). On Slide 2, four tasks were presented. Participants needed to list the compounds that were represented with circles (Task 2) and ellipses (Task 3) in the animations. Then they had to choose the animation correctly representing the process of osmosis (Task 4) and provide the reasons for their choice (Task 5). Animation 2 showed the process of osmosis correctly, whereas Animations 1 and 3 were incorrect representations of this process.

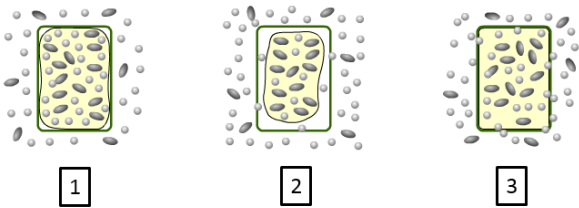
The plant in the photo is called the grape hyacinth. The animations of the particle movement below represents what is going on in an individual cell of the grape hyacinth when the plant is wilted.



What compound is represented by the circles?

What compound is represented by the ellipses?

Which animation of particle movement from 1 to 3 accurately represents the process in the cells of grape hyacinth in the photo? State the reasons for your choice.



**Figure 1.** Screenshot of Slide 2. Slide 1 looked the same, except that the tasks right of the photo (Tasks 2–5) were replaced with the following text (Task 1): “Explain why the plant wilted.”

### Eye-Movement Measures

To determine students’ visual attention towards different elements of slides while solving the tasks, we focused on the total amount of time (total fixation duration; in some studies, also referred to as dwell time) spent in particular areas of interest (AOI). For this purpose, the tasks displayed on the computer screen were divided into several AOIs with regard to the placement of the parts investigated. Fixations refer to maintaining the visual gaze on a certain location, and fast eye movements from one location to another are called saccades (Susac, Bubic, Kaponja, Planinic, & Palmovic, 2014). The identification of saccades or fixations is based on the motion of gaze during each sample collected. When both the velocity and acceleration thresholds (in our case: 30 degrees per second and 8,000 degrees per second squared) are exceeded, a saccade begins; otherwise, the sample is labelled as a fixation.

### Data Collection

The selected science problem is one of 11 science problems that were tested in the project Explaining Effective and Efficient Problem-Solving of the Triplet Relationship in Science Concepts Representations. This was a broader project on students’ understanding of authentic problems in the area of chemistry, physics, and biology. Each problem was context based and required students to link different levels of representations in order to understand and explain the science concept under consideration. The participants had no time limit, and it took them approximately 30 minutes to solve 11 science problems. Prior to the testing, the participants were informed about the purpose of the study, the method used, and their role in it. They sat in front of a screen in a faculty laboratory and had to place their heads in a special head-supporting stand to ensure stability and gather the most optimal recordings. The distance between the screen and the eyes was 60 cm. After the initial calibration and validation (through a nine-point algorithm), participants solved the science problems out loud and the experimenter wrote their answers down. The science problems were presented in the same order for all participants. We followed their eye-movement measures with eye tracker EyeLink 1000 (35 mm lens, horizontal orientation) and used the associated software (Experiment Builder to prepare the experiment and a connection with EyeLink; Data Viewer for obtaining the data and basic analysis) for the recordings and data analyses. Data on corneal reflection and pupil responses were collected from the right eye (monocular data collection) at 500 Hz.

## Data Analysis

We decided to focus only on the problem of osmosis in the present paper. Data analysis was performed using R (R Core Team, 2016). Statistical hypotheses were tested at 5% alpha error rate if not mentioned differently. Testing of the hypotheses on the difference between groups was non-directional.

First, we analyzed the accuracy of students' responses to different tasks. For each task, frequency analysis was performed to describe the percentage of students in different groups providing a correct answer. Fisher's exact test was used to test the difference in accuracy among the three groups of students, using Šidák's correction for multiple (i.e., five) tests, which resulted in a .0102 alpha-error rate for an individual test. Cramér's V coefficient was calculated as a measure of effect size. *Post hoc* pairwise Fisher's exact tests with correction for multiple comparisons were calculated with the R 'rcompanion' package (Mangiafico, 2017).

Next, we examined how much time students fixated on particular AOIs within each slide, i.e., on the photo, each of the three animations presented, and other parts of the slide (instructions, questions, animation numbers, or elsewhere). Because the frequency distributions of total fixation duration across individuals showed a large asymmetry or kurtosis, robust measures were used to describe it: median (*Mdn*) was calculated as a measure of central tendency, and median absolute deviation around the median (*MAD*) was used as a measure of dispersion. The Wilcoxon rank sum test was used for comparing eye-tracking variables in different groups of students, using Šidák's correction for multiple (i.e., five) tests, which resulted in a .0102 alpha-error rate for an individual test. A coefficient *r* was calculated as a measure of the effect size (a *Z* value resulting from the Wilcoxon rank sum test was divided by the square root of total sample size).

We also analyzed the frequency distribution of different levels of thought reflected in students' responses to Tasks 1 and 5.

## RESULTS AND DISCUSSION

**Table 1** shows the percentage of students that provided correct answers to each of the five tasks. Even though there was an overall increase of percent correct with educational level as expected, the result of Fisher's exact test did not reach statistical significance for Task 1, asking about the causes of the plant wilting, nor for Task 4, which required students to choose the correct visualization of the process of osmosis. The percent correct differed across groups statistically significantly on Tasks 2 and 3, which asked about the chemical compounds represented in the visualizations by the circles and ellipses. The primary school students solved these tasks less accurately than the secondary school and university students. In Task 5, which required the students to give the reasons for choosing a specific animated visualization of the process of osmosis, the accuracy of the three groups was statistically significantly different as well, with primary school students less accurate than secondary school and university students (even though approximately one-third of university students also failed to provide correct arguments for their choice of animation). The significant differences in accuracy between the seventh-grade primary school students group and the other two groups of students is most probably a result of limited experiences of the first group with higher levels of explanation (i.e., the submicroscopic level) and the fact that the Slovenian primary school science curriculum introduces animations of particles in the eighth-grade chemistry course (Bačnik et al., 2011). Longer education provided older students with more knowledge about various science concepts, as expected. In addition, at the end of primary school, a transition between the concrete operational level and formal operational stage occurs and students develop the ability to think about abstract concepts and become capable of deductive reasoning (Inhelder & Piaget, 1958). Datta and Dutta Roy (2015) suggested that abstract reasoning is also related to spatial visualization ability. In our study, better-developed deductive reasoning and spatial visualization ability might have enabled older students to relate more effectively the photo showing the result of the wilting process at the macroscopic level and the animations of this process at the submicroscopic level, and provide a larger percentage of correct responses.

The association between the age group and the accuracy of responses was moderate (see the column Cramér's V in **Table 1**) but, overall, the older the students were, the higher was the percentage of those that solved the tasks correctly. The research question of how accuracy of response affects the time spent observing the phenomena displayed at the macroscopic and submicroscopic levels is thus inherently related to the question of how these times differ between age groups, even though the two questions do not overlap completely (Cramér's V was quite low for some of the tasks). In subsequent analyses, we decided to focus more on the accuracy of response and its relation to eye-tracking measures.



**Table 1.** Comparison of percent of correct answers for different tasks in different groups of students

Task	Total sample (N = 79)		Group 1: Primary school students (n = 30)		Group 2: Secondary school students (n = 29)		Group 3: University students (n = 20)		Cramér's V	Fisher's exact test p	Results of post hoc tests
	f	%	f	%	f	%	f	%			
Task 1	55	70	19	63	18	62	18	90	0.26	.064	
Task 2	51	65	10	33	24	83	17	85	0.51	< .001	1 < 2,3
Task 3	39	49	8	27	18	62	13	65	0.36	.007	1 < 2,3
Task 4	56	71	20	67	18	62	18	90	0.25	.084	
Task 5	31	39	3	10	15	52	13	65	0.48	< .001	1 < 2,3

**Table 2.** Descriptive statistics for the time different groups of students spent on Slide 1 areas of interest

Area of interest	Total sample (N = 79)		Task 1 solved incorrectly (n = 24)		Task 1 solved correctly (n = 55)		Wilcoxon rank sum test		Effect size r
	Mdn	MAD	Mdn	MAD	Mdn	MAD	W	p	
<b>Total duration of fixations (in sec)</b>									
Photo	5.5	3.9	7.1	5.8	4.4	2.9	796	.148	-.16
Animation 1	9.3	7.1	11.7	10.9	8.8	5.9	800	.138	-.17
Animation 2	20.2	13.2	22.9	11.2	18.2	13.1	712	.585	-.06
Animation 3	4.5	3.3	6.0	4.1	3.7	2.3	857	.036	-.24
Other parts	19.8	7.4	22.3	7.2	18.5	7.0	831	.069	-.21
<b>Percent fixation duration</b>									
Photo	.079	.057	.084	.048	.076	.061	711	.593	-.06
Animation 1	.158	.085	.186	.092	.151	.077	717	.550	-.07
Animation 2	.302	.161	.275	.139	.325	.163	555	.267	.13
Animation 3	.069	.044	.090	.076	.066	.035	712	.585	-.06
Other parts	.309	.113	.289	.088	.319	.110	583	.417	.09

**Table 3.** Descriptive statistics for the time different groups of students spent on Slide 2 areas of interest

Area of interest	Total sample (N = 79)		Tasks 4 and 5 solved incorrectly (n = 49)		Tasks 4 and 5 solved correctly (n = 30)		Wilcoxon rank sum test		Effect size r
	Mdn	MAD	Mdn	MAD	Mdn	MAD	W	p	
<b>Total duration of fixations (in sec)</b>									
Photo	1.9	1.8	2.2	2.4	1.4	1.4	958	.025	-.25
Animation 1	9.8	9.6	16.3	13.0	5.3	3.6	1177	< .001	-.50
Animation 2	29.7	19.3	27.5	20.1	30.3	15.6	624	.597	.11
Animation 3	5.0	5.0	8.2	7.8	2.2	1.5	1195	< .001	-.52
Other parts	27.5	10.3	29.3	9.3	24.9	12.1	865	.192	-.15
<b>Percent fixation duration</b>									
Photo	.020	.020	.022	.027	.016	.019	875	.168	-.16
Animation 1	.131	.108	.177	.131	.075	.060	1136	< .001	-.46
Animation 2	.374	.193	.289	.184	.459	.124	363	< .001	.42
Animation 3	.060	.055	.097	.066	.032	.018	1188	< .001	-.51
Other parts	.331	.094	.316	.086	.363	.138	534	.042	.23

We compared the eye-tracking measures in students that solved tasks correctly and in those that were not able to solve the tasks correctly. The differences in eye-tracking measures could indicate that these two groups processed data at a different thought level. The time an individual spends on a certain AOI may indicate both the speed of processing as well as how much attention he or she needs to devote to the AOI to solve the task. For example, two students may both spend 20% of their time on a certain AOI, yet one may process the information more slowly and will therefore need to spend more absolute time on the AOI. It is thus important to compare both the absolute and relative amount of time spent on a certain AOI between groups because the relative amount may be more indicative of which AOI is more important for solving the task. **Tables 2** and **3** contain both types of data.

For Slide 1, we split the entire sample of students into two groups: the group of students that solved Task 1 correctly (i.e., they accurately explained why the plant wilted) and the group of those that did not provide a correct

answer. Overall, students that provided a correct response needed less time to derive their answer ( $Mdn = 61.3$  s,  $MAD = 30.3$  s) than students that failed to answer correctly ( $Mdn = 80.8$  s,  $MAD = 24.9$  s), Wilcoxon rank sum test  $W = 901$ ,  $p = .010$ ,  $r = -.29$ . Even though in **Table 2** a tendency can be observed that students that solved Task 1 correctly spent less time on Slide 1 AOIs than students that did not solve this task correctly, the differences did not reach statistical significance ( $p > .0102$ ) for any of the AOI examined, neither when total duration of fixation was compared between the two groups nor when the percentage of time fixating on a certain AOI was compared between the groups.

For Slide 2, we split the students into two groups: ones that solved both Tasks 4 and 5 correctly (i.e., they chose the animation representing the osmosis process correctly and accurately explained what was going on during this process) and those that did not solve Tasks 4 and 5 correctly. In primary school group, three students (10%) solved both tasks correctly. Fourteen (48%) secondary school students and 13 (65%) university students solved both tasks correctly.

Overall, students that solved Tasks 4 and 5 correctly needed less time to derive their answer ( $Mdn = 64.2$  s,  $MAD = 23.0$  s) than students that failed to provide correct answers ( $Mdn = 90.1$  s,  $MAD = 34.4$  s), Wilcoxon rank sum test  $W = 1034$ ,  $p = .002$ ,  $r = -.34$ . **Table 3** shows that, in comparison to the group of students that did not solve Tasks 4 and 5 correctly, the group of students that solved both tasks correctly spent relatively less time on incorrect animations (Animations 1 and 3) and relatively more time on the correct animation (Animation 2). Eye movements during solving tasks on Slide 2 therefore differentiated between successful and unsuccessful problem solvers, similar as in the study by Hegarty et al. (1995).

Out of 30 students that responded correctly to Tasks 4 and 5, 15 students (50%) provided responses that combined the macro-, micro-, and submicroscopic level of thought, such as "The amount of water outside the cell decreased. That's why the water left the vacuole. The vacuole contracted because of the osmotic pressure." Eight students (27%) provided responses at the macro- and microscopic level of thought; for example, "The plant wilted because inside of the cell the concentration was higher than outside and the water went out for the concentration to be equalized." Three students (10%) used a combination of micro- and submicroscopic level, such as "The water goes to the environment because the molecules of water go out of the plant's cells. The cell membrane disassembles from the cell wall." Two students responded at the macroscopic level ("Because the water went out.") and two students responded at a combined macro- and submicroscopic level ("The particles that are soluble in water can cross the membrane, whereas others cannot"). No student used the symbolic level of explanation.

These findings support the statement made by Tomažič and Vidic (2012) that observation alone at a macroscopic level of the processes is not sufficient, and that a link must be made with the submicroscopic level. The results also show that students regularly use the microscopic level or a combination of the microlevel with the macroscopic and submicroscopic levels to explain the biological phenomena studied. What is unique for biology learning is complex, hierarchical organization of life and a nested knowledge domain, which, according to Treagust and Tsui (2013), provides a rationale for using four levels of external representation (macro-, micro-, submicro-, and symbolic levels) instead of three levels (macro-, submicro-, and symbolic levels) as proposed by Johnstone (1991) in chemistry education.

We also compared the percentage of time spent on the photo and on the animations (all animations combined) in the group of students that provided a correct response at the macroscopic level and the group of students that provided a correct response including other levels of thought. The percentage of time spent on the photo when solving Task 1 was larger in students that provided the response at the macroscopic level ( $n = 29$ ,  $Mdn = .124$ ,  $MAD = .101$ ) than in students that provided the response at some higher level ( $n = 26$ ,  $Mdn = .052$ ,  $MAD = .026$ ), Wilcoxon rank sum test  $W = 583$ ,  $p < .001$ ,  $r = .47$ . In addition, the percentage of time spent on the animations when solving Task 1 was smaller in students that provided the response at the macroscopic level ( $n = 29$ ,  $Mdn = .513$ ,  $MAD = .186$ ) than in students that provided the response at some higher level ( $n = 26$ ,  $Mdn = .643$ ,  $MAD = .086$ ), Wilcoxon rank sum test  $W = 185$ ,  $p < .001$ ,  $r = -.44$ . Therefore, students that responded to the question "Why did the plant wilt?" with a correct answer at the macroscopic level paid relatively more attention to the photo and relatively less attention to the animations than those whose response contained higher levels of thought.

In addition, the total score for responding correctly to all four tasks on Slide 2 was calculated (min = 0, max = 4 points). The correlation between the total score and percentage of time spent on different AOIs on Slide 2 is shown in **Table 4**. As can be seen, the Slide 2 total score was positively related to the percentage of time spent on the correct animation and negatively related to the percentage of time spent on incorrect animations of the osmosis process. Participants that understood the process of osmosis better observed the correct animation relatively more and spent less time on the incorrect animations. Most likely, when describing the processes represented in Animation 2 (Task 5), these students were also observing this animation for a longer period.

**Table 4.** Correlations between total score on Slide 2 tasks and the percentage of time spent on different areas of interest on Slide 2

	1	2	3	4	5
1. Score on Slide 2					
2. Percent fixation on the photo	-.18				
3. Percent fixation on Animation 1 (incorrect)	-.37**	.19			
4. Percent fixation on Animation 2 (correct)	.45***	-.33**	-.62***		
5. Percent fixation on Animation 3 (incorrect)	-.44***	.11	.32**	-.40***	
6. Percent fixation on other parts of Slide 2	.01	-.03	-.32**	-.26*	-.26*

Note: Spearman correlation coefficients are shown. Coefficients in italics would not be considered statistically significant after using the Šidák correction for multiple tests, resulting in a .0034 single-test alpha error rate.  
\* $p < .05$ . \*\* $p < .01$ . \*\*\* $p < .001$ .

**Table 5.** Levels of correct and incorrect responses to Tasks 1 and 5

Level of thought	Incorrect response						Correct response					
	Primary school students		Secondary school students		University students		Primary school students		Secondary school students		University students	
	<i>f</i>	%	<i>f</i>	%	<i>f</i>	%	<i>f</i>	%	<i>f</i>	%	<i>f</i>	%
<b>Task 1</b>												
No response	1	3	1	4	0	0	–	–	–	–	–	–
Macroscopic	2	7	2	7	1	5	15	52	8	29	6	30
Macro- & Submicroscopic	3	10	1	4	0	0	1	3	0	0	0	0
Macro- & Microscopic	5	17	4	14	1	5	2	7	6	21	4	20
Macro- & Micro- & Submicroscopic	0	0	1	4	0	0	1	3	1	4	1	5
Microscopic	0	0	1	4	0	0	0	0	3	11	7	35
Micro- & Submicroscopic	0	0	1	4	0	0	0	0	0	0	0	0
Task 1: Total	11	37	11	38	2	10	19	63	18	62	18	90
<b>Task 5</b>												
No response	3	10	2	7	0	0	–	–	–	–	–	–
Macroscopic	3	10	1	3	2	10	2	7	0	0	0	0
Macro- & Submicroscopic	2	7	1	3	3	15	0	0	0	0	0	0
Macro- & Microscopic	7	23	1	3	1	5	0	0	6	21	2	10
Macro- & Micro- & Submicroscopic	1	3	0	0	0	0	0	0	0	0	3	15
Microscopic	6	20	8	28	0	0	0	0	9	31	7	35
Submicroscopic	2	7	1	3	0	0	0	0	0	0	0	0
Micro- & Submicroscopic	3	10	0	0	1	5	1	3	0	0	1	5
Task 5: Total	27	90	14	48	7	35	3	10	15	52	13	65

A closer look at the responses of different age groups of students to Task 1 (see Table 5) revealed that, when responding to the task correctly, the majority of primary school students provided answers at the macroscopic level, such as “The water went out,” whereas among the secondary school and university students a large percentage of higher-level responses or combinations of different levels of responses could be observed. For example, some of these students provided responses at the microscopic level, such as “The amount of water outside the cell decreased. That’s why the water left the vacuole. The vacuole contracted because of the osmotic pressure,” and some provided a response that was a combination of the macro- and microscopic level of thought, such as “The plant wilted because it did not have enough water and thus the vacuole contracted.” Individual students across all age groups provided a combination of the macro-, micro-, and submicroscopic levels of thought (e. g., “The plant wilted because water particles and solute particles exited the cells due to the turgor pressure”).

In Task 5, similar patterns in the distribution of correct responses across different age groups could be observed as in Task 1. Whereas primary school students’ answers to Task 5 mostly contained inaccuracies, the correct responses in secondary school and university students all included the microscopic level of thought. One of the responses that included this level only was: “The water goes out of the cell. The vacuole shrinks. The cell membrane disassembles from the cell wall.” An example of the combination of the microscopic level with the macroscopic one was: “The water exits the cell and the plant wilts.” Individual students also used a combination of micro- and submicroscopic levels, such as “The particles that are soluble in water can pass through the membrane, whereas others cannot.” A higher percentage of older students combining the macroscopic level with some other level is consistent with Larkin, McDermott, Simon, and Simon (1980), who report that experts think about and can respond to questions at many levels.

Different types of incorrect responses to Tasks 1 and 5 were observed across all age groups. Whereas in Task 1 incorrect responses of primary school students mostly included the macroscopic level (either alone or combined with a higher level of thought), in Task 5 a larger amount of incorrect answers at the micro- and submicroscopic levels could be observed (Table 5). This can be a result of the task explicitly orienting primary school students' attention towards the animations and the movement of particles, but because these students have limited experience with higher levels of explanations their higher-level responses were mostly wrong. These results confirm Ainsworth's (2008) findings that complicated scientific concepts, represented with multiple forms of external representations, can offer unique benefits; however, there is considerable evidence to show that learners often fail to exploit these advantages, and in the worse cases this can completely inhibit learning. Therefore, she recommended that these powerful tools need careful handling and often considerable experience before learners can use them successfully, which is probably why primary school students had the most difficulties.

## CONCLUSIONS

This article provides evidence to suggest that the learning of difficult scientific topics, such as water balance in plants, with multiple representations at the macroscopic and submicroscopic levels can be either helpful or confusing for a learner, depending on the individual's level of development of scientific reasoning. As expected, primary school students showed less knowledge and understanding of water balance in plants than secondary school and university students. Students that solved the questions about water balance in plants correctly spent less time observing biological phenomena displayed at the macroscopic and submicroscopic levels than those that were unable to answer correctly. Our focus was on thought levels students used to explain water balance in plants. Students with correct answers more often provided responses that combined the macro-, micro-, and submicroscopic levels of thought. A closer look at the responses of different groups of students revealed that, when responding to the task correctly, the majority of primary school students provided answers at the macroscopic level, but when their explanations included higher levels or combinations of different levels of thought the percentage of incorrect answers increased substantially.

These findings suggest that beginners (i.e., primary school students) using multiple representations at the macroscopic and submicroscopic levels do not achieve the same level of knowledge and understanding as more experienced secondary school and university students. Therefore, as suggested by Ainsworth (2008), one should consider how these visualizations can be designed to allow beginners to develop their expertise in using multiple external representations, which are a prerequisite for in-depth learning about complex scientific topics. Furthermore, a teacher should support students in interpreting multiple external representations so that they will be able to use them while learning about complex biological phenomena.

The study provides evidence that students regularly use the microscopic (cellular or subcellular) level of thought to explain biological phenomena. This indicates that we should use four levels of external representation (the macro-, micro-, submicro-, and symbolic levels) in designing biology textbooks, online resources and in biology lessons. Our suggestion for implementation of multiple external representations would be to use arrows (as suggested by Ainsworth, 2008) and zooming-in, which would explicitly show gradual transitions from a macroscopic to a submicroscopic level of representation (or even further to a symbolic one). New digital technologies are very handy for applying zooming-in in online (electronic) educational materials, allowing students to independently progress through different levels of external representations in their own pace. This should help students establish links between different external representations and develop comprehensive understanding of biological concepts.

## REFERENCES

- Ainsworth, S. (1999). The functions of multiple representations. *Computers & Education*, 33(2), 131-152. [https://doi.org/10.1016/S0360-1315\(99\)00029-9](https://doi.org/10.1016/S0360-1315(99)00029-9)
- Ainsworth, S. (2008). The educational value of multiple-representations when learning complex scientific concepts. In J. K. Gilbert, M. Reiner, & M. Nakhleh (Eds.), *Visualization: Theory and practice in science education* (pp. 191-208). Dordrecht: Springer. [https://doi.org/10.1007/978-1-4020-5267-5\\_9](https://doi.org/10.1007/978-1-4020-5267-5_9)
- AlHarbi, N. N., Treagust, D. F., Chandrasegaran, A. L., & Won, M. (2015). Influence of particle theory conceptions on pre-service science teachers' understanding of osmosis and diffusion. *Journal of Biological Education*, 49(3), 232-245. <https://doi.org/10.1080/00219266.2014.923488>
- Bačnik, A., Bukovec, N., Vrtačnik, M., Poberžnik, A., Križaj, M., Stefanovik, V., & Preskar, S. (2011). *Program osnovna šola. Kemija. Učni načrt [Primary school programme. Chemistry. Syllabus]*. Ljubljana: Zavod RS za šolstvo. Retrieved from

[http://www.mizs.gov.si/fileadmin/mizs.gov.si/pageuploads/podrocje/os/prenovljeni\\_UN/UN\\_kemija.pdf](http://www.mizs.gov.si/fileadmin/mizs.gov.si/pageuploads/podrocje/os/prenovljeni_UN/UN_kemija.pdf)

- Ballard, D. H., Hayhoe, M. M., Pook, P. K., & Rao, R. P. (1997). Deictic codes for the embodiment of cognition. *Behavioral and Brain Sciences*, 20(4), 723–742. <https://doi.org/10.1017/s0140525x97001611>
- Chen, S.-C., She, H.-C., Chuang, M.-H., Wu, J.-Y., Tsai, J.-L., & Jung, T.-P. (2014). Eye movements predict students' computer-based assessment performance of physics concepts in different presentation modalities. *Computers & Education*, 74, 61-72. <https://doi.org/10.1016/j.compedu.2013.12.012>
- Cook, M., Carter, G., & Wiebe, E. N. (2008). The interpretation of cellular transport graphics by students with low and high prior knowledge. *International Journal of Science Education*, 30(2), 239–261. <https://doi.org/10.1080/09500690601187168>
- Cook, M., Wiebe, E. N., & Carter, G. (2008). The influence of prior knowledge on viewing and interpreting graphics with macroscopic and molecular representations. *Science Education*, 92(5), 848–867. <https://doi.org/10.1002/sce.20262>
- Datta, S., & Dutta Roy, D. (2015). Abstract reasoning and spatial visualization in formal operational stage [sic]. *International Journal of Scientific and Research Publications*, 5(10), 1–6.
- Ferk Savec, V., Hrast, Š., Devetak, I., & Torkar, G. (2016). Beyond the use of an explanatory key accompanying submicroscopic representations. *Acta Chimica Slovenica*, 63(4), 864–873. <https://doi.org/10.17344/acsi.2016.2835>
- Gegenfurtner, A., Lehtinen, E., & Säljö, R. (2011). Expertise differences in the comprehension of visualizations: a meta-analysis of eye-tracking research in professional domains. *Educational Psychology Review*, 23, 523–552. <https://doi.org/10.1007/s10648-011-9174-7>
- Hannus, M., & Hyönä, J. (1999). Utilization of illustrations during learning of science textbook passages among low- and high-ability children. *Contemporary Educational Psychology*, 24, 95–123. <https://doi.org/10.1006/ceps.1998.0987>
- Hasni, A., Roy, P., & Dumais, N. (2016). The teaching and learning of diffusion and osmosis. *Eurasia Journal of Mathematics, Science and Technology Education*, 12(6), 1507–1531. <https://doi.org/10.12973/eurasia.2016.1242a>
- Hegarty, M., Mayer, R. E., & Monk, C. A. (1995). Comprehension of arithmetic word problems: A comparison of successful and unsuccessful problem solvers. *Journal of Educational Psychology*, 87(1), 18–32. <https://doi.org/10.1037/0022-0663.87.1.18>
- Henderson, J. M. (2007). Regarding scenes. *Current Directions in Psychological Science*, 16(4), 219–222. <https://doi.org/10.1111/j.1467-8721.2007.00507.x>
- Hinze, S. R., Rapp, D. N., Williamson, V. M., Shultz, M. J., Deslongchamps, G., & Williamson, K. C. (2013). Beyond ball-and-stick: Students' processing of novel STEM visualizations. *Learning and Instruction*, 26, 12–21. <https://doi.org/10.1016/j.learninstruc.2012.12.002>
- Inhelder, B., & Piaget, J. (1958). *The growth of logical thinking: From childhood to adolescence*. Oxon: Routledge. <https://doi.org/10.1037/10034-000>
- Johnstone, A. H. (1991). Why is science difficult to learn? Things are seldom what they seem. *Journal of Computer Assisted Learning*, 7(2), 75–83. <https://doi.org/10.1111/j.1365-2729.1991.tb00230.x>
- Johnstone, A. H., & Mahmoud, N. A. (1980). Isolating topics of high perceived difficulty in school biology. *Journal of Biological Education*, 14(2), 163–166. <https://doi.org/10.1080/00219266.1980.10668983>
- Just, M. A., & Carpenter, P. A. (1976). Eye fixations and cognitive processes. *Cognitive Psychology*, 8(4), 441–480. [https://doi.org/10.1016/0010-0285\(76\)90015-3](https://doi.org/10.1016/0010-0285(76)90015-3)
- Just, M. A., & Carpenter, P. A. (1980). A theory of reading: From eye fixations to comprehension. *Psychological Review*, 87(4), 329–354. <https://doi.org/10.1037/0033-295X.87.4.329>
- Lai, M.-L., Tsai, M.-J., Yang, F.-Y., Hsu, C.-Y., Liu, T.-C., Lee, S. W.-Y., ... Tsai, C.-C. (2013). A review of using eye-tracking technology in exploring learning from 2000 to 2012. *Educational Research Review*, 10, 90–115. <https://doi.org/10.1016/j.edurev.2013.10.001>
- Larkin, J., McDermott, J., Simon, D. P., & Simon, H. A. (1980). Expert and novice performance in solving physics problems. *Science*, 208, 1335–1342. <https://doi.org/10.1126/science.208.4450.1335>
- Lin, Y.-Y., Holmquist, K., Miyoshi, K., & Ashida, H. (2017). Effects of detailed illustrations on science learning. *Instructional Science*, 45, 557–581. <https://doi.org/10.1007/s11251-017-9417-1>
- Malińska, L., Rybska, E., Sobieszczuk-Nowicka, E., & Adamiec, M. (2016). Teaching about water relations in plant cells: An uneasy struggle. *CBE-Life Sciences Education*, 15(4), ar78. <https://doi.org/10.1187/cbe.15-05-0113>



- Mangiafico, S. S. (2017). Package 'rcompanion'. Retrieved from <https://cran.r-project.org/web/packages/rcompanion/rcompanion.pdf>
- Marek, E. A., Cowan, C. C., & Cavallo, A. M. (1994). Students' misconceptions about diffusion: How can they be eliminated? *The American Biology Teacher*, 74–77. <https://doi.org/10.2307/4449757>
- Odom, A. L. (1995). Secondary & college biology students' misconceptions about diffusion & osmosis. *The American Biology Teacher*, 409–415. <https://doi.org/10.2307/4450030>
- Odom, A. L., & Barrow, L. H. (1995). Development and application of a two-tier diagnostic test measuring college biology students' understanding of diffusion and osmosis after a course of instruction. *Journal of Research in Science Teaching*, 32(1), 45–61. <https://doi.org/10.1002/tea.3660320106>
- Odom, A. L., & Kelly, P. V. (2001). Integrating concept mapping and the learning cycle to teach diffusion and osmosis concepts to high school biology students. *Science Education*, 85(6), 615–635. <https://doi.org/10.1002/sce.1029>
- Panizzon, D. (2003). Using a cognitive structural model to provide new insights into students' understandings of diffusion. *International Journal of Science Education*, 25(12), 1427–1450. <https://doi.org/10.1080/0950069032000052108>
- R Core Team. (2016). *R: A language and environment for statistical computing*. R Foundation for Statistical Computing, Vienna, Austria. Retrieved from <https://www.R-project.org/>
- Rayner, K. (1998). Eye movements in reading and information processing: 20 years of research. *Psychological Bulletin*, 124(3), 372–422. <https://doi.org/10.1037/0033-2909.124.3.372>
- Rayner, K. (2009). The 35th Sir Frederick Bartlett Lecture: Eye movements and attention in reading, scene perception, and visual search. *The Quarterly Journal of Experimental Psychology*, 62(8), 1457–1506. <https://doi.org/10.1080/17470210902816461>
- Sanger, M. J., Brecheisen, D. M., & Hynek, B. M. (2001). Can computer animations affect college biology students' conceptions about diffusion & osmosis? *The American Biology Teacher*, 63(2), 104–109. <https://doi.org/10.2307/4451051>
- She, H. C. (2004). Facilitating changes in ninth grade students' understanding of dissolution and diffusion through DSLM instruction. *Research in Science Education*, 34(4), 503–525. <https://doi.org/10.1007/s11165-004-3888-1>
- Sperelakis, N. (2012). *Cell physiology source book: Essentials of membrane biophysics*. London: Elsevier. <https://doi.org/10.1016/B978-0-12-387738-3.02001-1>
- Stieff, M., Hegarty, M., & Deslongchamps, G. (2011). Identifying representational competence with multi-representational displays. *Cognition and Instruction*, 29(1), 123–145. <https://doi.org/10.1080/07370008.2010.507318>
- Susac, A., Bubic, A., Kaponja, J., Planinic, M., & Palmovic, M. (2014). Eye movements reveal students' strategies in simple equation solving. *International Journal of Science and Mathematics Education*, 12(3), 555–577. <https://doi.org/10.1007/s10763-014-9514-4>
- Tai, R. H., Loehr, J. F., & Brigham, F. J. (2006). An exploration of the use of eye-gaze tracking to study problem-solving on standardized science assessments. *International Journal of Research & Method in Education*, 29(2), 185–208. <https://doi.org/10.1080/17437270600891614>
- Tomažič, I., & Vidic, T. (2012). Future science teachers' understandings of diffusion and osmosis concepts. *Journal of Biological Education*, 46(2), 66–71. <https://doi.org/10.1080/00219266.2011.617765>
- Treagust, D. F., & Tsui, C.-Y. (2013). Conclusion: Contributions of multiple representations to biological education. In D. F. Treagust & C.-Y. Tsui (Eds.), *Multiple representations in biological education* (pp. 349–367). Dordrecht: Springer. [https://doi.org/10.1007/978-94-007-4192-8\\_19](https://doi.org/10.1007/978-94-007-4192-8_19)
- Tsui, C. Y., & Treagust, D. F. (2013). Introduction to multiple representations: Their importance in biology and biological education. In *Multiple Representations in Biological Education* (pp. 3–18). Dordrecht: Springer. [https://doi.org/10.1007/978-94-007-4192-8\\_1](https://doi.org/10.1007/978-94-007-4192-8_1)
- Zuckerman, J. T. (1998). Representations of an osmosis problem. *The American Biology Teacher*, 27–30. <https://doi.org/10.2307/4450407>



# Study of the Effect of Environmental Education on Environmental Awareness and Environmental Attitude Based on Environmental Protection Law of the People's Republic of China

Yang Li<sup>1\*</sup>

<sup>1</sup> Law School, Minzu University of China, Beijing, CHINA

Received 26 November 2017 • Revised 8 February 2018 • Accepted 28 February 2018

## ABSTRACT

The rapid development of technology and economy in past years has largely enhanced the quality of life. However, the emergence of various social and environmental problems could be discovered when looking back. Implementing the idea of environmental education in school systems therefore becomes a primary issue to promote environmental education. In this case, the practice of governmental policies has to implement the idea of environmental education in school systems, provide complete and comprehensive resources, information, and channels for environmental education, and positively promote the practice of Environmental Protection Law of China and the legislation revision. Aiming at college students in Beijing City, total 322 students in 6 different departments of Minzu University of China are selected as the research objects for the 16-week (3hrs per week for total 48 hours) experimental teaching. Total 322 copies of questionnaire are distributed, and 287 valid copies are retrieved, with the retrieval rate 89%. The research results reveal significantly positive effects of 1.environmental education on environmental awareness, 2.environmental awareness on environmental attitude, and 3.environmental education on environmental attitude. It is expected to enhance environmental awareness, attitudes, and behaviors related to environmental education based on the revision of Environmental Protection Law of the People's Republic of China.

**Keywords:** environmental protection law, environmental education, environmental awareness, environmental attitude

## INTRODUCTION

Along with the advance of western industry, various countries largest developed the economy and accelerated the industrial process in the end of 1960s, when natural environment was seriously destroyed and lots of environmental problems appeared, e.g. water, air, and soil pollution, radioactive waste, and the flood of other toxic substances. After the long-term damage of natural environment, a lot of scholars proposed warnings and regarded it as the source of environmental consciousness. After then, people gradually concerned about global environmental resources and realized that such resources should not be squandered by human beings. The rapid development of technology and economy in past years has largely enhanced the quality of life. Nevertheless, the emergence of various social and environmental problems could be discovered when looking back. Rubbish war was everywhere in cities and the countryside and air and noise pollution, cadmium rice incident caused by polluted water quality were heard from time to time. It is definitely regulated in Article 6 of Environmental Protection Law of the People's Republic of China that "Citizens shall raise their awareness of environmental protection, adopt low-carbon and economical lifestyles, and conscientiously fulfill their obligation to protect environment". Accordingly, people notice that environmental problems could be thoroughly solved merely by establishing people's keen awareness and brand-new understanding of the living environment and cultivating the environmental action skills.

### **Contribution of this paper to the literature**

- To have students be glad to participate in environmental education learning and easily absorb the contents to pay attention to environmental education and promote the performance on environmental awareness, environmental attitudes, and environmental behaviors.
- Educational sectors could encourage schools holding environmental education related activities or contests related to the revision of Environmental Protection Law of the People's Republic of China to guide students developing the professions and creativity and establishing the awareness and behaviors to active understand the revision of Environmental Protection Law of the People's Republic of China.
- Schools should cultivate students' thinking and action abilities to participate in and improve environmental problems, design environment experience courses aiming at environmental protection issues.

Environmental education, particularly environmental law-related education, is the basic measure to promote environmental attitudes and environmental behaviors.

As a result, implementing the idea of environmental education in school systems becomes a primary issue to promote environmental education. The practice of governmental policies therefore has to base on legal empowerment. For the legal empowerment, the idea of environmental education should be implemented in school systems, citizens, communities, schools, non-profit organizations (NPO), government departments, and enterprises should be provided with complete and comprehensive resources, information, and channels for environmental education, and people should positively promote the legislation and revision of Environmental Protection Law of China. Past research on students' environmental awareness, attitudes, and behaviors related to Environmental Protection Law of the People's Republic of China was limited to largely impact the practice of environmental education in schools. Aiming at the revision of Environmental Protection Law of the People's Republic of China, this study intends to discuss the effect of environmental education on environmental awareness and environmental attitude.

## **LITERATURE REVIEW**

### **Environmental Protection Law of the People's Republic of China**

The following clauses are quoted in the standard content. The valid version of reference without a date is applied. The major terms and definitions in "Measures for the Administration of National Environmental Protection Standards Revision" (National Central Science and Technology [2017] No. 1) are described as below.

- (1) Pollution prevention techniques: The techniques to avoid or reduce pollutants in the production process in order to reduce the emission of pollutant.
- (2) Pollution control techniques: The techniques to eliminate or reduce the effect of pollutants on environment.
- (3) Environmental management measurement: The management and measures applied in enterprises to effectively prevent and control pollutants.
- (4) Available techniques of pollution prevention and control: The pollution prevention techniques, pollution control techniques, and environmental management measurement applied in the pollution prevention and control process, according to domestic environmental needs and economic standard in certain period, to have stable emission of pollutants achieving national standard of pollutant emission and the scale application.
- (5) Advanced available techniques of pollution prevention and control: The available techniques of pollution prevention and control should at least have the stable emission of a major pollutant be lower than 70% of the limit of national pollutant emission standard.

### **Environmental Education**

Clements, Chenyang, and McCright (2014) pointed out the nature of environmental education as to understand the environment through education, to be aware and conscious of the relationship between people's subjective desires& needs and the environment, and to modify and reflect people's attitudes towards and value of the pursuit and utilization of natural environment. Hall (2013) regarded environmental education as the process of cognitive value and concept clarification to develop, understand, and appreciate necessary skills and attitudes in the mutual relationship among humans, culture and the creatures, and physical environment. Environmental education should also be applied to the decision-making of environmental quality problems and self-oriented codes of conduct. Atkins (2016) specifically explained that environmental education was not simply to objectively understand the environment, but to objectively understand people's desires and value and the relationship with the environment

as well as to perceive and cultivate the self-restricted and self-reflected survival and life and the permanent relationship with natural environment. Liu et al. (2016) pointed out environmental education as the educational process aiming at the association among, people, the nature, and the artificial environment, including environmental problems of population issues, pollution issues, energy distribution and energy conservation issues, natural conservation issues, technology development, traffic infrastructure, and urban and rural planning. The relationship between humans and the environment was understood through education. Gifford (2014) referred environmental education as humans' understanding, attitudes, and cultivation towards the environment. From a certain aspect, it was the education without personal choice or freedom. Specifically speaking, it should be the education or cultivation for everyone that it essentially was mandatory and required for citizens. Minton et al. (2016) regarded environmental education as the process to achieve the improvement, the education process to clarify concepts and form value, and the knowledge, skills, and attitudes required for human development and the understanding of the mutual relationship among people, culture and creature, and physical environment. Environmental education also taught people to make decisions when facing issues related to environmental quality and to develop self-behavior criteria.

Referring to Chen (2016), the following dimensions are applied to environmental education in this study.

- (1) Natural system: General ideas of environment, globe, and biosphere.
- (2) Global resources: The distribution, consumption, management, and conservation of natural resources as well as the pollution.
- (3) Human and environment: Since humans are a part of the environment, the law should be reinforced to establish the environmental value.

### **Environmental Awareness**

Li and Chen (2014) regarded environmental awareness as the formation of cognition in the memory through the process of sensory stimulation, notice, identification, and perception. Cui, Hoje, and Velasquez (2015) defined environmental awareness as the emotional attitudes towards the environment and environmental value, leading students emotionally and conceptually to respect the environment, concern about the environment, and to further correctly treat the environment. Morrison, Roderick, and Parton (2015) regarded environmental awareness as the public perceiving the understanding of the entire environment and the related problems. Environmental awareness referred to people's understanding and awareness of the environment and the related issues (such as waste disposal, noise and air pollution, water pollution, soil pollution, ozone layer destruction, greenhouse effect, and acid rain) (Brehma, Eisenhauerb, & Stedman, 2013). The so-called environmental awareness, also called "environmental consciousness", referred to the concerns and comprehension of environmental problems (Ramkissoon, Smith, & Weiler, 2013), meaning that an individual could be aware of the existence of problems and cultivate the perception, appreciation, and exploration of the environment through the interaction with the environment and the cultivation of aesthetics (Gifford & Nilsson, 2014). Environmental awareness was the process of people storing, understanding, and reassembling environmental stimulation. In this case, environmental awareness was the process of people storing, understanding, and reassembling environmental stimulation. It involved in the elements in the environment as well as the involved events, the emotion of individuals and groups, and the symbolic meanings (Hirsh, 2014).

Referring to Lee (2017), environmental awareness in this study contains the following three dimensions.

- (1) Environmental knowledge: Including issues in biology and ecology, e.g. the composition and function of ecosystem, the flow of materials and energy in ecosystem, ethnic groups and clusters, and effects of humans on ecosystem.
- (2) Problem knowledge: Containing the resources in natural environment and the environmental problems derived from the overuse of resources.
- (3) Action knowledge skills: The variety of environmental action, the use of proper actions to solve problems, and the use of environmental action knowledge and skills.

### **Environmental Attitudes**

Environmental attitudes are explained as personal attitudes for or pro and liking or disliking the environment or affairs related to the environment (Brick & Lewis, 2014). Pepper and Leonard (2016) defined environmental attitudes, with persistency and consistency, as individual opinions about the value of the environment and human responsibility and role in the environment as well as the emotional inclination of loathe or favor and agreement or oppose according to the cognition and feeling. Some scholars considered that the content of environmental attitudes should focus on environmental ethics, including natural resources, environmental protection, environmental development, ecological relations, and environmental responsibility (Frantz & Mayer, 2014). Lokhorst, Hoon, le

Rutte and de Snoo (2014) regarded environmental attitudes as individual persistent and consistent psychological awareness, feeling evaluation or action idea and intention towards environmental problems. Snowden (2014) pointed out environmental attitudes as organizational and reliable personal characters enhancing an individual to pay attention and concern and to eventually become environmental protection action. Aiming at specific objects in the environment, the psychological reaction, including good and bad evaluation, was generated according to past learning experience or perceived experience in the natural environment. Generally speaking, environmental attitudes referred people's judgment of the belief in natural resources (good or bad, positive or negative) to the evaluation criteria (Kurusu, 2016).

Referring to Cheng, Wu, and Huang (2014), three major dimensions of environmental attitudes are covered in this study.

- (1) Environmental sensitivity: Referring to the seriousness of environmental problems and individual opinions.
- (2) Environmental belief: Referring to the opinion about the mutual relationship between individuals and natural environment.
- (3) Environmental value: Trinidad, Sharplin, Ledger, and Broadley (2014) regarded value as a comprehensive structure of individuals distinguishing right & wrong and good & bad to make decisions.

### **Research Hypothesis**

Liu et al. (2016) pointed out an objective of environmental education as to enhance the environmental knowledge of the educated (containing, but not restricted to, relevant environment legislation knowledge). Although a lot of scholars doubted whether the enhancement of environmental knowledge would change individual environmental attitudes and behaviors, the measurement of environmental knowledge, at least, could understand the effectiveness of environmental education in cognition (Brehma et al., 2013). Environmental education was regarded as an important tactic to solve environmental problems. Moreover, the key spirit of environmental education was to cultivate a person presenting environmental awareness, environmental attitudes, and environmental behaviors and becoming the citizen with environmental literacy. Taylor (2016) pointed out environmental education as the process of concept cognition and value clarification to develop the skills and attitudes required for understanding and appreciating the mutual relationship among humans, culture and the creatures, and physical environment. Chen (2016) stated that the promotion of environmental education aimed to enhance the citizens understanding the dependency between individuals & society and the environment, enhance the citizens' environmental awareness, environmental ethics and responsibility, environmental protection law rights and obligations, and further maintain ecological balance of environment, respect life, enhance social justice, and cultivate the learning community between environment citizens and environment to achieve the sustained-yield development. The following hypothesis is therefore proposed in this study.

**H1:** Environmental education presents significantly positive effects on environmental awareness.

Li and Chen (2014) discovered that students with high environmental awareness outperformed those with low environmental awareness on environmental attitudes. In the research on senior high school students' environmental awareness and environmental protection action, Taylor, Gretel, and Zaleha (2016) indicated that ones with higher protection awareness and more active protection action appeared more contact with natural environment, revealing the relationship between awareness and practice attitudes. In the research on communities environmental activity participants' attitudes (cognition, emotion, and action inclination), Morrison et al. (2015) mentioned that activity participants showed more positive and significant environmental attitudes and higher cognition, emotion, and action inclination than those without participation. The participation in activity would change the environmental attitudes and remarkably enhance the action inclination. Research pointed out positive correlations between students' environmental knowledge and environmental attitudes, i.e. students with higher environmental awareness revealing more positive attitudes towards environmental problems (Hirsh, 2014). Wong, Lin, and Tan (2014) indicated that elementary school students had achieved moderate environmental awareness and even presented positive attitudes towards environmental problems. In this case, the following hypothesis is proposed in this study.

**H2:** Environmental awareness shows remarkably positive effects on environmental attitudes.

In addition to achieving the cognition goal, environmental education particularly needs to cultivate correct environmental attitudes of the educated and the environmental behaviors responsible for daily practice (Kurusu, 2016). Apparently, the establishment of attitudes was primary for promoting environmental education. Tonge, Ryan, Moore, and Beckley (2014) stated that the effect of "environmental education action research teaching" on students' environmental education cognition appeared no difference from traditional teaching. However, the process of planning, action, review, reflection, and reaction showed remarkable influence on students' environmental attitudes and behaviors. Pepper and Leonard (2016) mentioned that environmental education aimed to have students understand the nature and realize the current condition and importance of environmental

**Table 1.** Confirmatory Factor Analysis

Research dimension	Overall fit	Analysis result
environmental education	$\chi^2=0(P<0.001)$ ; DF=0; GFI=1.00; CFI=1.00	good overall model fit
environmental awareness	$\chi^2=0(P<0.001)$ ; DF=0; GFI=1.00; CFI=1.00	good overall model fit
environmental attitude	$\chi^2=0(P<0.001)$ ; DF=0; GFI=1.00; CFI=1.00	good overall model fit

problems as well as cultivate the knowledge, attitudes, and skills for environmental protection to create the living environment with sustainable utilization of resources. Regarding the practice of environmental education, Zaleha (2013) stressed on reinforcing students' basic environmental knowledge and environmental action skills, assisting students in establishing positive environmental attitudes, and regarding the practice of environmental protection behaviors as the final goal of environmental education. Cheng et al. (2014) revealed that environmental education aimed to have students understand the nature, realize current conditions and importance of environmental problems, and cultivate the knowledge, attitudes, and skills for environmental protection through environmental education to create the living environment with sustainable utilization of resources; and, the final goal of environmental education was to cultivate the environmental cognition and environmental attitudes. Accordingly, the following hypothesis is proposed in this study.

**H3:** Environmental education reveals notably positive effects on environmental attitude.

## RESEARCH METHOD AND DESIGN

### Operational Definition and Measurement of Variable

#### *Environmental education*

Environmental education is divided into natural system, global resources, and human and environment. The scale is referred to Chen (2016). The reliability coefficients appear natural system 0.83, global resources 0.81, and human and environment 0.87.

#### *Environmental awareness*

Environmental awareness contains three dimensions of environmental knowledge, problem knowledge, and action knowledge skills. The scale is referred to Lee (2017). The reliability coefficients show environmental knowledge 0.84, problem knowledge 0.82, and action knowledge skills 0.86.

#### *Environmental attitudes*

Referring to Cheng et al. (2014), environmental attitudes are divided into environmental sensitivity, environmental belief, and environmental value. The reliability coefficients present environmental sensitivity 0.85, environmental belief 0.88, and environmental value 0.90.

### Research Object

Aiming at college students in Beijing City, 322 students in six departments of Minzu University of China are preceded 16-week (3hr per week, for total 48 hours) experimental teaching. Total 322 copies of questionnaire are distributed, and 287 valid copies are retrieved, with the retrieval rate 89%.

### Verification of Reliability and Validity

The reliabilities of dimensions in this study achieve above 0.7, showing high reliability of the dimensions. The construct validity of the scale in this study is analyzed with Confirmatory Factor Analysis. From **Table 1**, the scale in this study presents favorable convergent validity and construct validity.

## ANALYSIS RESULT

### Correlation Analysis

From **Table 2**, environmental education, environmental awareness, and environmental attitude show notable correlations, revealing the possibility of multiollinearity among dimensions. Nested Model Analysis could be used

**Table 2.** Correlation Analysis

Research dimension	$\alpha$	environmental education	environmental awareness	environmental attitude
environmental education	0.83			
environmental awareness	0.85	0.33**		
environmental attitude	0.87	0.26**	0.36**	

**Table 3.** Overall linear structural model analysis

	X <sup>2</sup> /Df	
Overall model fit	1.738	
	GFI	0.982
	AGFI	0.924
	RMR	0.006

Note: \* stands for  $p < 0.05$ , \*\* for  $p < 0.01$ , \*\*\* for  $p < 0.001$

**Table 4.** Nested Model Analysis

Model	$\chi^2$	$\Delta\chi^2$	GFI	CFI	RMSEA
Theoretical model	251.26		0.982	0.991	0.08
Model 1: Hypothesis test	255.48	4.22*	0.982	0.991	0.08
Model 2: Hypothesis test	260.61	5.13*	0.982	0.991	0.08
Model 3: Hypothesis test	266.25	5.64*	0.982	0.991	0.08

**Table 5.** Hypothesis test

Research hypothesis	Correlations	Empirical result	P	Result
H1	+	0.372	0.00	supported
H2	+	0.383	0.00	supported
H3	+	0.351	0.00	supported

for solving such a problem. The significant correlation among research dimensions also reveals the match with research hypotheses.

### Overall Model Discussion

Regarding overall model fit, **Table 3**, the overall model fit criteria  $\chi^2/Df=1.738$ , smaller than the standard 3, and  $RMR=0.006$  show the appropriateness of  $\chi^2/DF$  and  $RMR$ . Furthermore, chi-square value is sensitive to sample size that it could not be directly used for judging the fit. However, the overall model fit criteria  $GFI=0.982$  and  $AGFI=0.924$  reach above the standard 0.9 (the closer  $GFI$  and  $AGFI$  to 1, the better model fit) that this model presents better fit indices.

### Research Hypothesis Discussion

Nested Model is utilized for testing the research hypotheses with chi-square differences. Since each Nested Model appears a degree of freedom, the set casual path coefficient 0 is remarkable when the difference of chi-square value between Nested Model and theoretical model achieves the significance. The research result shows the model achieving the significance. The Nested Model analysis is shown in **Table 4** and the hypothesis test results are shown in **Table 5**.

### CONCLUSION

The research results reveal that students with better environmental awareness present more positive environmental attitudes. Environmental awareness refers to the process of humans absorbing, understanding, storing, and organizing information in the environment. It does not simply involve in various elements in the environment, but also involves in affairs, emotional attributes, and symbolic meanings in the environment. For this reason, environmental awareness is affected by individual attributes, perceived environment, and experience. The cognition refers to individual understanding, knowledge, and opinions of affairs and is the powerful evaluation. To have students appear environmental awareness, the following dimensions should be taken into account. To have students present environmental awareness of environmental protection and energy saving, e.g. regarding the improvement of environmental quality as personal responsibilities and concerning the effect of air pollution and water pollution on humans, support the participation and understanding of the revision of Environmental Protection Law of the People's Republic of China for the natural environment, concern about environmental



protection issue at any time, participate in environment protection donation, report illegal behaviors, join in procession and petition actions, believe in the insistence on garbage classification, community maintenance, and reduction of resources, and not care about whether others would take the similar actions. In regard to the cognition of ecological environment, to be strongly proud of and be glad of the natural landscape and ecology, to feel that there are many people would struggle for the environment in People's Republic of China, and to present strong perception to imitate them. It therefore could have students present the knowledge of creatures or physical characteristics in the nature or natural environment, e.g. habitats, wetland conservation, through environmental education, or enhance students' knowledge of the environment to result in proper attitudes and enhance the positive environmental attitudes. In this case, using environmental education for reinforcing the understanding of the revision of Environmental Protection Law of the People's Republic of China could reinforce students' environmental awareness and environmental attitudes.

## ACKNOWLEDGEMENTS

The study was supported by "National Social Science Fund, China (Grant No. 16CFX035).

## RECOMMENDATIONS

From the research results and findings, practical suggestions are proposed in this study.

1. To timely apply video media or board games with environmental protection elements or situational teaching with environmental issues to have students be glad to participate in environmental education learning and easily absorb the contents to pay attention to environmental education and promote the performance on environmental awareness, environmental attitudes, and environmental behaviors.
2. Educational sectors could encourage schools holding environmental education related activities or contests related to the revision of Environmental Protection Law of the People's Republic of China to guide students developing the professions and creativity and establishing the awareness and behaviors to active understand the revision of Environmental Protection Law of the People's Republic of China, e.g. competition of resource recycle among classes and selection of microfilms related to the revision of Environmental Protection Law. It could subtly lead students actively participating in the discussion of environmental problems and thinking of solutions as well as cultivating the environmental responsibility to positively present positive environmental attitudes and behaviors.
3. In the environmental education related to the revision of Environmental Protection Law of the People's Republic of China, schools should cultivate students' thinking and action abilities to participate in and improve environmental problems, design environment experience courses aiming at environmental protection issues (e.g. waste disposal, resource recycle, green consumption, national land development, ecological conservation, environmental policies), practice opportunity education, and guide students actively participating in the discussion and thinking of the revision of Environmental Protection Law of the People's Republic of China, realizing the responsibility for the environment, actively developing moral courage, and positively presenting positive environmental attitudes and behaviors.

## REFERENCES

- Atkins, E. (2016). Environmental Conflict: A Misnomer? *Environment, Climate Change and International Relations*, 99.
- Brehma, J. M., Eisenhauer, B. W., & Stedman, R. C. (2013). Environmental Concern: Examining the Role of Place Meaning and Place Attachment. *Society & Natural Resources: An International Journal*, 26(5), 40. <https://doi.org/10.1080/08941920.2012.715726>
- Brick, C., & Lewis, G. J. (2014). Unearthing the "Green" Personality Core Traits Predict Environmentally Friendly Behavior. *Environment and Behavior*. *Environment and Behavior*, 48(5), 635-658. <https://doi.org/10.1177/0013916514554695>
- Chen, M. F. (2016). Impact of fear appeals on pro-environmental behavior and crucial determinants. *International Journal of Advertising*, 35(1), 74-92. <https://doi.org/10.1080/02650487.2015.1101908>
- Cheng, T. M., Wu, H., & Huang, L. M. (2014). The influence of place attachment on the relationship between destination attractiveness and environmentally responsible behavior for island tourism in Penghu, Taiwan. *Journal of Sustainable Tourism*, 21(8), 1166-1187. <https://doi.org/10.1080/09669582.2012.750329>
- Clements, J. M., Chenyang, X., & McCright, A. M. (2014). An examination of the 'greening of Christianity' thesis among Americans, 1993-2010. *Journal for the Scientific Study of Religion*, 53(2), 373-391. <https://doi.org/10.1111/jssr.12116>

- Cui, J., Hoje, J., & Velasquez, M. G. (2015). The influence of Christian religiosity on managerial decisions concerning the environment. *Journal of Business Ethics*, 132(1), 203-231. <https://doi.org/10.1007/s10551-014-2306-5>
- Frantz, C. M., & Mayer, F. S. (2014). The importance of connection to nature in assessing environmental education programs. *Evaluating Environmental Education*, 41, 85-89. <https://doi.org/10.1016/j.stueduc.2013.10.001>
- Gifford, R. (2014). Environmental Psychology Matters. *Annual Review of Psychology*, 65(1), 541-579. <https://doi.org/10.1146/annurev-psych-010213-115048>
- Gifford, R., & Nilsson, A. (2014). Personal and social factors that influence pro-environmental concern and behavior: A review. *International Journal of Psychology*, 49(3), 141-157.
- Hall, G. E. (2013). Evaluating change processes: Assessing extent of implementation (constructs, methods and implications). *Journal of Educational Administration*, 51(3), 264-289. <https://doi.org/10.1108/09578231311311474>
- Hirsh, J. B. (2014). Environmental sustainability and national personality. *Journal of Environmental Psychology*, 38, 233-240. <https://doi.org/10.1016/j.jenvp.2014.02.005>
- Kurisu, K. (2016). *Pro-environmental Behaviors*. Japan: Springer Verlag.
- Lee, K. S. (2017). *Evolusi Bandar Di Negeri Selangor - Suatu Kajian Dari Perpektif Sejarah Bandar Kajang* (Published in Aturcara Seminar Kajang), 10-1-2017, Kajang Heritage Centre.
- Li, D., & Chen, J. (2014). Significant life experiences on the formation of environmental action among Chinese college students. *Environmental Education Research*, 21(4), 612-630. <https://doi.org/10.1080/13504622.2014.927830>
- Liu, R., Hou, B., Sun, P., Li, H., & Wang, J. (2016). Vegetable farmers' use intention towards biopesticides and its influencing factors: Based on the survey in Jiangsu Province, China. *Carpathian Journal of Food Science and Technology*, 8(1), 14-22.
- Lokhorst, A. M., Hoon, C., le Rutte, R., & de Snoo, G. (2014). There is an I in nature: The crucial role of the self in nature conservation. *Land Use Policy*, 39, 121-126. <https://doi.org/10.1016/j.landusepol.2014.03.005>
- Minton, E. A., Lynn, R. K., Jiuan, T. S., & Tambyah, S. K. (2016). Addressing criticisms of global religion research: A consumption-based exploration of status and materialism, sustainability, and volunteering behavior. *Journal for the Scientific Study of Religion*, 55(2), 365-383. <https://doi.org/10.1111/jssr.12260>
- Morrison, M., Roderick, D., & Parton, K. (2015). Religion does matter for climate change attitudes and behavior. *PLoS ONE*, 10(8), e0134868. <https://doi.org/10.1371/journal.pone.0134868>
- Pepper, M., & Leonard, R. (2016). How ecotheological beliefs vary among Australian Churchgoers and consequences for environmental attitudes and behaviors. *Review of Religious Research*, 58(1), 101-124. <https://doi.org/10.1007/s13644-015-0234-1>
- Ramkissoon, H. L. D., Smith, G., & Weiler, B. (2013). Testing the dimensionality of place attachment and its relationships with place satisfaction and pro-environmental behaviours: A structural equation modelling approach. *Tourism Management*, 36, 552-566. <https://doi.org/10.1016/j.tourman.2012.09.003>
- Snowden, J. (2014). A brief background of scouting in the United States 1910 to today [Web blog message]. Retrieved on April 11, 2015 from <http://www.troop97.net/bsahist1.htm>
- Taylor, B. (2016). The Greening of Religion Hypothesis (Part One): From Lynn White, Jr and Claims That Religions Can Promote Environmentally Destructive Attitudes and Behaviors to Assertions They Are Becoming Environmentally Friendly. *Journal for the Study of Religion, Nature & Culture*, 10(3), 268-305. <https://doi.org/10.1558/jsrnc.v10i3.29010>
- Taylor, B., Gretel, V. W., & Zaleha, B. (2016). The Greening of Religion Hypothesis (Part Two): Assessing the Data from Lynn White, Jr, to Pope Francis. *Journal for the Scientific Study of Religion*, 10(3), 306-378. <https://doi.org/10.1558/jsrnc.v10i3.29011>
- Tonge, J., Ryan, M. M., Moore, S. A., & Beckley, L. E. (2014). The effect of place attachment on pro-environment behavioral intentions of visitors to coastal natural area. *Journal of Travel Research*, 54(6), 730-743. <https://doi.org/10.1177/0047287514533010>
- Trinidad, S., Sharplin, E., Ledger, S., & Broadley, T. (2014). Connecting for innovation: Four universities collaboratively preparing pre-service teachers to teach in rural and remote Western Australia. *Journal of Research in Rural Education*, 29(2), 1-13.

- Wong, D., Lin, C. M., & Tan, P. (2014). Migration, settlement and the rise of a new middle class in Malaysian chinese Society: A case study of Kajang. *Malaysian Journal of Chinese Studies*, 3(1), 61-78.
- Zaleha, B. D. (2013). Our only Heaven': Nature veneration, quest religion, and pro-Environment behavior. *Journal for the Study of Religion, Nature & Culture*, 7(2), 131-153. <https://doi.org/10.1558/jsrnc.v7i2.131>

**<http://www.ejmste.com>**



<http://www.ejmste.com>



<https://twitter.com/ejmste>



<https://www.facebook.com/ejmste>



<http://modestum.co.uk/>



[publications@modestum.co.uk](mailto:publications@modestum.co.uk)

# Contextualizing the EU's "Responsible Research and Innovation" Policy in Science Education: A Conceptual Comparison with the Nature of Science Concept and Practical Examples

Antti Laherto <sup>1\*</sup>, Lorenz Kampschulte <sup>2</sup>, Miikka de Vocht <sup>3</sup>, Ron Blonder <sup>4</sup>, Sevil Akaygun <sup>5</sup>,  
Jan Apotheker <sup>6</sup>

<sup>1</sup> University of Helsinki, FINLAND

<sup>2</sup> IPN-Leibniz Institute for Science and Mathematics Education / Deutsches Museum, GERMANY

<sup>3</sup> Helsinki Upper Secondary School of Natural Sciences, FINLAND

<sup>4</sup> Weizmann Institute of Science, ISRAEL

<sup>5</sup> Bogazici University, TURKEY

<sup>6</sup> University of Groningen, THE NETHERLANDS

Received 17 January 2018 • Revised 14 March 2018 • Accepted 15 March 2018

## ABSTRACT

The European Union (EU) encourages science education to be oriented towards the concept of Responsible Research and Innovation (RRI), i.e. socially and ethically sensitive and inclusive processes of science and technology. Connecting RRI to prevailing concepts in science education, such as the Nature of Science (NoS), may facilitate the incorporation of RRI in curricula and classrooms. We carried out a conceptual comparison between the EU's RRI policy and a recent reconceptualization of NoS, known as the expanded Family Resemblance Approach. We discuss how the socio-institutional nature of science in that approach closely connects to the RRI and can provide a means for RRI teaching. To illustrate these opportunities, we present practical classroom approaches developed in the EU-funded project IRRESISTIBLE, and survey results on teachers' perspectives on RRI. The aim of this work is to understand better the potential implications of RRI to research and practice in science education.

**Keywords:** family resemblance approach, nature of science, responsible research and innovation, teachers' attitudes

## INTRODUCTION

Responsible Research and Innovation (RRI) was introduced as a cross-cutting political aim in the 7<sup>th</sup> Framework Programme of the European Union (EU), and it continues to be a key concept in the current Horizon 2020 programme (Owen, Macnaghten, & Stilgoe, 2012). RRI entails a socially and ethically sensitive and inclusive process of science and technology (European Commission, 2012) which pushes academia and the industrial research and development sector to cultivate their practices and engage more deeply with the remainder of the society. The aim is to ensure that societal actors work together, mutually responsively, from the beginning to the end of research and innovation process, and that both the processes and outcomes of research and innovation are aligned with the values, needs and expectations of the European societies.

A number of calls and projects have been initiated to this end. So far, the process has made universities develop their curricula (see e.g. the HEIRRI project) to address RRI in higher education, and made industry and its stakeholders adjust their practices accordingly (see e.g. projects EnRRICH, BigPicnic, COMPASS, HEIRRI, JERRI, MARINA, NewHoRRIZon, ProGReSS, OpenUP, PRISMA, PROSO, Res-AGorA, RRI-ICT Forum, RRI-Practice, SATORI, SIS-RRI, SMART-map, STARBIOS 2). However, reaching the RRI goal of involving societal actors in research and innovation needs not only researcher training and new management systems in academia, but also a

### Contribution of this paper to the literature

- The study analyses the implications of the EU's "Responsible Research and Innovation" (RRI) policy to research and practice in science education.
- The study shows the connections of the RRI policy to the Nature of Science concept.
- The study illustrates the opportunities and challenges of incorporating RRI in science education by presenting practical classroom approaches and results on teachers' attitudes.

change of thinking by the rest of society. School (science) education is a key to that, in order to raise a generation which does not want to sit outside the processes of science and innovation. The recent recommendations of the expert group visioning the European agenda of 'Science Education for Responsible Citizenship' explicitly state that "Science teachers and educators also have a responsibility to embed concepts of Responsible Research and Innovation (RRI) directly into their teaching" (European Commission, 2015, p. 22). Considering the great influence of earlier EU policy documents – for example the push from the 'Science Education Now: A Renewed Pedagogy for the Future of Europe' report (European Commission, 2007) for the inquiry-based science education movement – it is likely that the concept of responsibility will be at the core of European science education in coming decades.

This long-term agenda has been implemented by the EU, by launching a number of RRI-related calls in science education in the H2020 programme and the earlier Framework Programme 7. Projects focusing on primary/secondary education include ENGAGE, IRRESISTIBLE, PARRISE, and RRI Tools. While the concept of RRI has not yet been embedded in national school education systems (Kearney, 2016), through these initiatives RRI is likely to have an influence in teacher professional development (de Vocht, Laherto & Parchmann, 2017) and school science across Europe. (For an overview of these projects and their approaches to RRI in science education, see Blonder, Zemler, & Rosenfeld, 2016). The number of such initiatives will grow, at least if the recommendations of science education experts (European Commission, 2015, p. 32) are followed.

The abovementioned projects have, however, faced challenges in contextualising RRI for science classrooms at primary and secondary levels (Blonder et al., 2016; de Vocht & Laherto, 2017). Identifying RRI related aspects that can be embedded in practices is more difficult in schools than in research. Researchers, for example, can engage more in public participation and 'citizen science' projects, and academia can strengthen its processes for addressing the ethical, social and equity concerns. Tools for these purposes have already been developed (see e.g. RRI Tools and toolkit.pe2020.eu). For schools and teachers, however, finding the common ground with RRI aims requires more elaboration. What knowledge and skills will the new generation need to be active citizens and professionals in the sense of RRI, and what kind of educational approaches support those objectives? Contextualising RRI in science education would be important since the impact of RRI in science education depends on how it resonates with and contributes to the current frameworks, approaches and activities of science education (de Vocht et al., 2017; de Vocht & Laherto, 2017).

RRI evidently contains ideas similar to several more established approaches in science education. Some of these connections have been studied already – for example, the PARRISE project took the Socio-Scientific Issues (SSI) framework (Sadler, Barab & Scott, 2007) to contextualise RRI in science education (Kárpáti & Király, 2016), and the RRI dimensions were also reflected against the SSI framework in the IRRESISTIBLE project (Blonder et al., 2016; Blonder, Rap, Zemler, & Rosenfeld, 2017). The ENGAGE, IRRESISTIBLE and PARRISE projects also embedded RRI in the inquiry-based science education (IBSE) approach, and the meaning of "responsibility" in inquiry-based learning has also been analysed in the Ark of Inquiry project (Bardone, Burget, Saage, & Taaler, 2007). However, RRI has not been elaborated with respect to the framework of Nature of Science (NoS) in science education (Erduran & Dagher, 2014; Lederman, 2007) – although there is an evident connection between these concepts.

In this paper we analyse the concept of RRI in relation to the framework of NoS in science education. The aim is to conceptualize RRI for science classrooms and to understand better the potential implications of RRI to research and practice in NoS teaching and learning. To illustrate and discuss the relationships, opportunities and challenges of incorporating RRI in science education, we discuss the results and experiences of the IRRESISTIBLE project: practical classroom approaches and teachers' attitudes.

## NATURE OF SCIENCE (NoS) IN SCIENCE EDUCATION

Nature of Science (NoS) is a predominant concept in research on science education as well as in reforms of science curricula. NoS education is uniformly advocated, since understanding the scientific processes and the relationships between science and society is considered to be a crucially important element of scientific literacy for all (e.g. Allchin, 2011; Roberts, 2007; Rudolph, 2000; Wenning, 2006). Yet, both the content and the approaches of NoS teaching have remained under debate. The most influential attempt to consolidate the concept has been the 'consensus model' (Lederman, 2007) listing the general characteristics of science and scientific knowledge such as



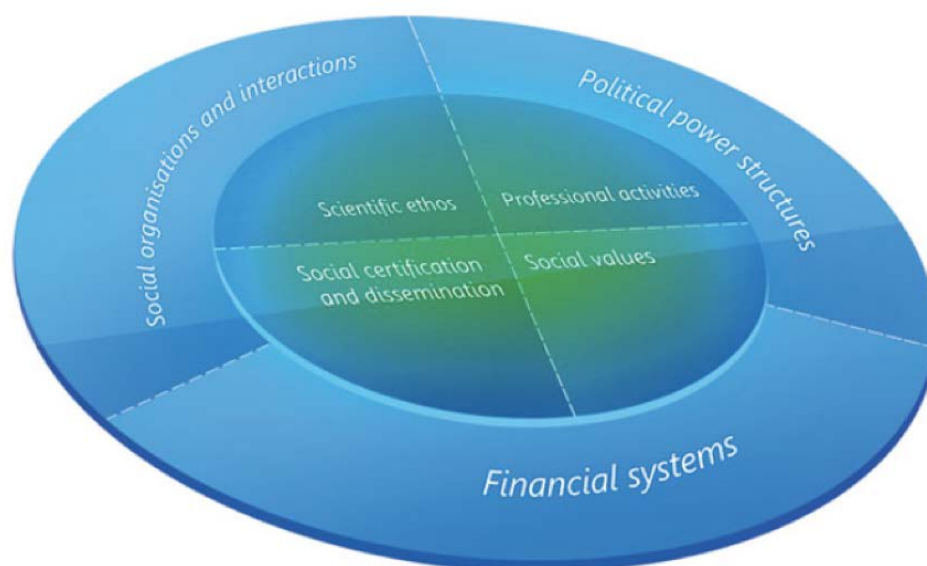
tentativeness, non-linearity, theory-ladenness, roles of observation, inference and theoretical entities, distinction between theories and laws, use of models, creativity, and social and cultural embeddedness (Lederman, 2007; McComas & Olson, 1998).

The consensus model has brought about a myriad of empirical research (Lederman & Lederman, 2014), pointing out shortcomings in students' and teachers' understanding of NoS and, typically, recommending a reflective and explicit teaching of the NoS features. The consensus model has also been increasingly criticized as incomplete and fragmented (e.g. Allchin, 2011). Elby and Hammer (2001) argued that generalizations such as "scientific knowledge is tentative" may be neither correct nor productive when they do not attend the context. Furthermore, while the consensus model chiefly concerns the cognitive and epistemic aspects of science and scientific knowledge, current trends in science education such as scientific literacy for all (Roberts, 2007; Roberts & Bybee, 2014), the socio-scientific issues framework (Sadler et al., 2007) and the responsibility aspects (European Commission, 2015) have emphasized the meanings of science as a social process and societal endeavour.

To address the critique and to articulate the complexity and social embeddedness of science better, the consensus view of NoS has recently been challenged by the Family Resemblance Approach (FRA) (Irzik & Nola, 2011, 2014). The FRA aims to provide a more elaborated, dynamic, holistic and systematic representation of science, not merely as epistemic inquiry but also as a social institution. The FRA implies that different sciences have a family resemblance, i.e. they include a sufficient number of similarities and partial overlaps. While the consensus view tends to address ideas about science quite separately, the FRA specifically aims to scrutinise the interrelatedness of those common characteristics.

The FRA considers science both as a cognitive-epistemic system and as a social institution (Irzik & Nola, 2014). The cognitive-epistemic system consists of four categories: Scientific Practices, Aims & Values of Science, Scientific Methods & Methodological Rules, and Scientific Knowledge. These should all be taught in authentic contexts so that students see how all the elements evolve and are unified. Science as a social institution consists of four categories: professional activities (publishing, reviewing, informing the public, etc.), scientific ethos (honesty, openness, critical attitude, universalism, respect for subjects and nature, etc.), social certification & dissemination (peer review; books & journals, etc.) and social values of science (autonomy, social utility, etc.) (Irzik & Nola, 2014).

In their expanded version of FRA for Nature of Science, Erduran and Dagher (2014) added three categories that they argued were missing from the original FRA: social organisation and interactions, political power structures, and financial systems (the outer ring in [Figure 1](#)). The Expanded FRA (Erduran & Dagher, 2014) aims to develop further Irzik's and Nola's FRA to NoS for science education both theoretically and practically.



**Figure 1.** Science as a social-institutional system in the Expanded Family Resemblance Approach wheel (Erduran & Dagher, 2014; based on Irzik & Nola, 2014). Reprinted by permission from Springer Customer Service Centre GmbH: Springer Nature, *Reconceptualizing the Nature of Science for Science Education: Scientific Knowledge, Practices and Other Family Categories* by Erduran, S., & Dagher, Z. (2014)

The suggestions that FRA presents an alternative to the consensus view have led to criticism. For instance, it has been alleged that it is too advanced for high school students. Furthermore, Lederman and Lederman (2014) argued that although FRA is formatted as a matrix, it is still just another list of features of science just as the consensus view is. Irzik and Nola (2014) responded that this argument misunderstands how the FRA was intended

to be used. In any case, the FRA has become a serious alternative to the consensus view. It has already gained kudos from empirical evidence, and been proven to be fruitful in teacher education (Erduran & Dagher, 2014).

The concept of Responsible Research and Innovation, further discussed in the next section elaborates the relationship between science and society. To scrutinize its connections to NoS approaches, we employed the Expanded FRA approach since it effectively addresses the complexity of the socio-institutional element of science which is underrepresented in most NoS views and, more generally, in traditional school science.

## DEFINITIONS OF RESPONSIBLE RESEARCH AND INNOVATION (RRI)

The EU concept of RRI may be viewed as an adaptation of many contemporary ethical, educational and political ideas arising from the interplay between research, industry and the public. RRI has a lot in common with the EU's "Science in Society" action plan launched in 2001, as well as with concepts like 'Public Engagement in Science', 'Dialogue', and 'Citizen science', all of which form a wider agenda for democratising science and open it up to citizens' participation. Since 2010, the focus has been on developing a framework for RRI, which aims to align research and innovation with the values, needs and expectations of society. RRI is a key objective in the Horizon 2020 framework of the European Commission. It sets guidelines for responsibility in research and innovation, such as anticipation, reflexivity, inclusion and responsiveness (Stilgoe, Owen, & Macnaghten, 2013).

An early definition of RRI was provided by Sutcliffe (2011) in "A report on Responsible Research and Innovation", focusing on societal desirability, inclusive participation, ethical considerations, openness, anticipation and governance. The same elements constitute the later definition by von Schomberg (2013, p. 9): "*Responsible Research and Innovation is a transparent, interactive process by which societal actors and innovators become mutually responsive to each other with a view to the (ethical) acceptability, sustainability and societal desirability of the innovation process and its marketable products (in order to allow a proper embedding of scientific and technological advances in our society)*". As noted in a comprehensive review by Burguet, Bardone, and Pedaste (2017), this definition is closely connected to the European Union policies and has remained widely used and acknowledged in the literature.

The definitions of Sutcliffe (2011) and von Schomberg (2013) were formalized in the white paper titled "Responsible research and innovation – Europe's ability to respond to societal challenges" (European Commission, 2012) which presents RRI as an umbrella of explicit key points:

- the consistent, ongoing *engagement* of all societal actors – such as academia, industry, policy makers, non-governmental organizations and civil society – in the research and innovation process;
- *gender equality* to unlock the full potential of individuals regardless of their gender;
- *science education* to equip better future researchers and other societal actors with the necessary knowledge and tools to participate fully and take responsibility for the research and innovation process;
- promoting *open access*, transparency and accessibility to boost innovation and to increase the use of scientific results by all societal actors;
- *ethical issues*, i.e. the deliberate focus of research and innovation on achieving increased social or environmental relevance, acceptability and benefit; and
- *governance* models for integrating all RRI elements with adaptable and better oversight mechanisms to anticipate and manage problems and opportunities.

In addition, two more keys have been recently added to the umbrella of RRI in the Report from the Expert Group on Policy Indicators (European Commission, 2015b):

- *Social justice/inclusion*, aimed at avoiding the unfair exclusion of particular groups from either participation in research and/or access to benefits arising from research; and
- *Sustainability*, aimed at bridging the current knowledge gap about the capability of research programmes and RRI initiatives to contribute to sustainable growth according to H2020 strategy.

Another – and less normative – approach to RRI has an emphasis on shared values between the aforementioned societal actors. Reforms may not always be directly beneficial to everyone. For example, open access may not be in the immediate interests of industry or science publishers. Therefore, societal actors have to compromise and collaborate mutually to find the best solutions via democratic and socio-empirical bottom-up processes (Ruggiu, 2015).

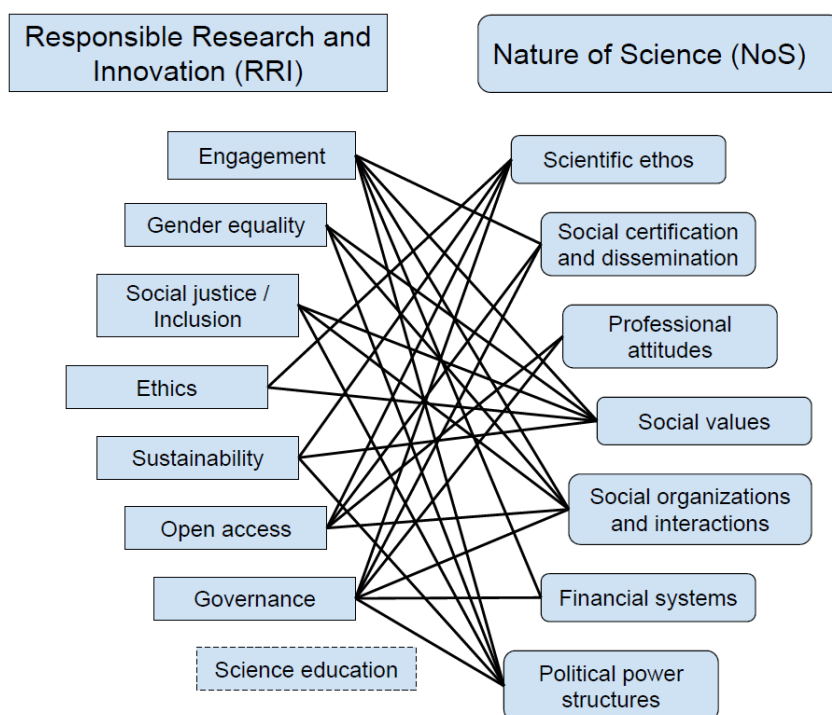
For these purposes, science education is one of the more important keys to socially and ethically-sensitive inquiry. In its recent science education visions, the European Commission states: "A more responsive science education can promote broader participation in knowledge-based innovation that meets the highest ethical standards and helps ensure sustainable societies into the future" (European Commission, 2015, p. 7). Yet, despite the breadth of definitions and conceptualizations in the literature on RRI in general (Burguet et al., 2017), science education aspects of the concept are still poorly developed.

## CONCEPTUAL RELATIONSHIP BETWEEN RRI AND NoS

In the recent white paper on European science education, the high-level expert group recommends that greater attention should be given to promoting Responsible Research and Innovation (RRI) and, in particular, “Science educators, at all levels, have a responsibility to embed social, economic and ethical principles into their teaching and learning in order to prepare students for active citizenship and employability” (European Commission, 2015). In their analysis of the meanings of RRI in science education, Heras and Ruiz-Mallén (2017) state that RRI-style science education should contribute to students’ engagement with science and empower them as responsible citizens, which requires critical thinking skills, reflexivity about science, and embedding of social and ethical processes. We argue that the socio-institutional aspects of NoS, as described in the previous section, provide a natural context for such discussion and a plausible way for operationalizing RRI in classrooms.

It is evident that Erduran and Dagher’s (2014) approach to NoS considers science not only as a body of knowledge but also as a complex process, involving not only facts but also multiple perspectives, interests, uncertainties and values. Thereby, the modern conception of NoS aligns with RRI in shifting the perception of science from being neutral, discipline-bound and isolated, to being inherently value-laden, transdisciplinary and responsive to socio-scientific issues. RRI addresses science as a socio-institutional system – not that much the cognitive-epistemic side. Thereby we focus on the elements of the Nature of Science presented in **Figure 1**.

Here we examine the eight normative key points of RRI, and how they are connected to the seven features of science as a social-institutional system. The connections are depicted in **Figure 2**, and discussed in detail in what follows.



**Figure 2.** The connections between the dimensions of Responsible Research and Innovation (RRI) and the socio-institutional dimensions of the Nature of Science (NoS) in the Expanded Family Resemblance Approach.

### RRI 1: Engagement

With the first RRI element, the European Commission calls for the consistent, ongoing involvement of society (the public, NGOs, industry, policy-makers and other stakeholders) from the beginning to the end of the research/innovation process, and for assessing and prioritizing social, ethical and environmental impacts, risks and opportunities, alongside the technical and commercial (Sutcliffe, 2011). Joint participation, mutual learning and agreed practices of all societal actors in the research and innovation process reflect the value of inclusiveness and are supposed to lead to greater societal acceptability of innovations and their benefits to society.

In science communication terms, this RRI principle calls for an ‘upstream engagement’ of the public. Societal challenges addressed in inquiry and innovation should be framed on the basis of widely-representative social, economic and ethical concerns and common principles. Having the involvement of the public and non-governmental groups, who themselves are mindful of the public benefit, is the key here.

In our view, these issues connect with five of the NoS features included in the Expanded Family Resemblance Approach:

- Social Values of Science
- Social Organisations and Interactions
- Political Power Structures
- Financial Systems

For example, the theme of Social Organisations and Interactions deals with “understanding how scientists work within and across social organizations and how they interact with each other as well as with stakeholders” (Erduran & Dagher, 2014), which is central in the RRI idea of engagement. The same goes for the interplay between science and politics (Political Power Structures) and that science has an economic dimension (Financial Systems). The engagement of different societal actors can be discussed in the context of these NoS features which have considerable overlap with the first RRI dimension.

## **RRI 2: Gender Equality**

With the second RRI dimension, the European Commission (2012) mostly refers to the need to address the under-representation of women in science and technology, such as by modernizing the research institutions, in particular their human resources management. Indeed, several studies have shown that women do not have equal numbers nor opportunities in these fields and this inequality has been difficult to solve due to structural and subconscious factors. But this dimension goes beyond this challenge, too: “The gender dimension must be integrated in research and innovation content” (European Commission, 2012). This represents a step to address the notion that the direction of scientific research is affected by informal influences within the culture of science itself.

Thereby, the Gender equality dimension of RRI can be addressed in the context of the following NoS elements:

- Social Values of Science
- Social Organisations and Interactions
- Political Power Structures

Political Power Structures are suggested as being a part of NoS, and by that concept Erduran and Dagher (2014) mean, besides other things, to unveil how science or any other human endeavour is not neutral in gender, and how science and science education can alienate girls and women. The RRI aim of enhancing gender equality and thereby “unlocking the full potential of society” (European Commission, 2012; see also Sutcliffe, 2011) can be promoted by discussing social values, organisations and interactions in NoS teaching.

## **RRI 2b: Social Justice / Inclusion**

The Social Justice / Inclusion element was added to RRI by an Expert Group on Policy Indicators (European Commission, 2015b) to avoid the exclusion of particular groups from participation in research and/or accessing benefits arising from research.

Accordingly, in NoS, social utility and freedom are considered to be social values that are embodied by science. Furthermore, according to the model, science education should address political power structures that can endanger social justice and social inclusion. In particular, science education has the responsibility to “unveil how scientific knowledge can become a tool for oppression and exploitation to countless victims when co-opted to serve gender, colonial, economic or other interests, and in the process, alienate individuals or groups like women, dehumanize communities, destroy ecologies and cultures” (Erduran & Dagher, 2014).

The RRI dimension of Social Justice / Inclusion touches and extends the Gender equality dimension. These themes are addressed in depth in the following NoS features:

- Social Values of Science
- Social Organisations and Interactions
- Political Power Structures

### RRI 3: Science Education

According to the RRI framework, science education plays a major role “[...] to better equip future researchers and other societal actors with the necessary knowledge and tools to fully participate and take responsibility in the research and innovation process” (European Commission, 2012). The Commission emphasizes the urgent need to boost the interest of children and youth in mathematics, science and technology for two purposes: to attract and educate future researchers, and to contribute to a scientifically literate society. Creative thinking skills are considered important in building the future with science and innovation (European Commission, 2012).

This RRI aspect overlaps significantly with the general aims of NoS teaching. The very same arguments for better science education have been made to justify NoS teaching. Yet, NoS has been conceptualised in science classrooms in a much more profound way. Furthermore, NoS teaching has been proven to increase the student interest and motivation (Roberts, 2007) called for by the EU (European Commission, 2012).

Yet, this RRI aspect (“Science education”) is not specific to individual NoS elements in the same way as the others are. This RRI aspect, above all, simply points out that science education is crucial in pursuing RRI in society in general. This general claim is certainly easy to agree with in the science education community, and all NoS elements can be considered to work to that end. Therefore, we consider the link of this RRI aspect to NoS to be different from other RRI aspects. It is more intimate, and it falls beyond the analysis of this level.

### RRI 4: Ethics

With the RRI dimension labelled ‘Ethics’, the EC necessitates respecting fundamental rights and the highest ethical standards in all research and innovation. This involves not only legal aspects but also the deliberate focus of research and innovation to achieve increased social or environmental relevance, acceptability and benefit. Thereby, the Ethics dimension of RRI emphasizes responsibility towards society and all its actors, and it “should not be perceived as a constraint to research and innovation, but rather as a way of ensuring high quality results” (European Commission, 2012).

This is clearly linked to scientific ethos as a feature in NoS. That element refers to “attitudes that scientists are expected to adopt and display in their interactions with their fellow scientists as well as in carrying out their scientific activities” (Irzik & Nola, 2014, pp. 1006–1007). When students are taught about scientific ethos (to deliver an image of the ethical practices of scientists), this RRI aspect can be addressed in a natural way. Also, in NoS, respecting the environment and social utility are considered to be social values that are embodied by science. Furthermore, in their model, Erduran and Dagher (2014) highlight that science has a financial dimension. Research funding institutions play a role in determining the goals of research, and most public research funders stress social and ethical acceptability and benefit.

Thereby, ethical issues highlighted by the RRI framework are deeply embedded in NoS, especially in the following dimensions:

- Scientific Ethos
- Social Values of Science
- Financial Systems

### RRI 4b: Sustainability

Sustainability is another element added to the concept by the Expert Group on Policy Indicators (European Commission, 2015b), recognizing that this key was not addressed sufficiently or explicitly enough in the six original dimensions. Yet, it is intimately linked to the Ethics dimension. Sustainability in RRI refers to fostering the capability of research programmes and RRI initiatives to contribute to sustainable growth according to the H2020 strategy. It stresses researchers’ responsibility for the safety and the quality of the environment.

As the ‘Ethics’ dimension, the sustainability dimension deals with Scientific Ethos in NoS (Erduran & Dagher, 2014). Furthermore, respecting the environment and its sustainability are considered Social Values that are embodied by science.

- Scientific Ethos
- Social Values of Science

### RRI 5: Open Access

The European Commission (2012) argues that in order to be responsible, research and innovation must be transparent and accessible. The EC has strongly and effectively pushed academia to provide free access to the results of publicly-funded research, including not only publications but data as well. Also, this aim is both value-

based and instrumental: openness is expected to boost innovation and increase the use of scientific results by all societal actors.

The aim of open access is certainly a key issue in Professional Activities but also several other aspects of NoS:

- Social Certification and Dissemination
- Professional Activities
- Scientific Ethos
- Social Organisations and Interactions

Discussing the RRI aspect of open access, and utilising some of the real data or scientific publications in science education, may raise students' awareness of the ways to act, think and communicate in science.

### **RRI 6: Governance**

The last RRI component mostly concerns policy-makers. The Governance dimension of RRI highlights policy-makers' responsibility to prevent harmful or unethical developments in research and innovation. The policy makers should develop better and adaptable oversight mechanisms with all stakeholders, to anticipate and manage problems and opportunities. This requires governance models for integrating all RRI elements (European Commission, 2012; Sutcliffe, 2011).

This RRI element does have implications for science education too. Since it implies that scientists have to disseminate and interact with policy-makers and discuss ethical issues with them and help them create oversight mechanisms, such issues are a part of NoS as a socio-institutional system.

In this sense, almost all of the NoS features have this aspect of governance.

- Social Certification and Dissemination
- Professional Activities
- Scientific Ethos
- Social Organisations and Interactions
- Political Power Structures
- Financial Systems

Put together, this comparison showed many mutual connections between the concepts of RRI and the socio-institutional dimensions of NoS in the Expanded Family Resemblance Approach. The latter offers a comprehensive platform to address all RRI aspects in science education. We will discuss these opportunities further after first presenting examples from an EU project.

## **RRI IN NoS TEACHING: EXAMPLES AND EXPERIENCES**

In this section we present examples and experiences from IRRESISTIBLE, EU project funded from 2013 to 2016, to illustrate how RRI may be implemented in NoS teaching and to explore teachers' responses to those approaches.

The goal of the IRRESISTIBLE project was to design activities that foster the involvement of students and the public in the process of RRI (Apotheker et al., 2017). To address the goals of RRI, the project was aimed at increasing students' knowledge about contemporary research and its nature. This was achieved by combining formal and informal educational approaches to discuss RRI issues in the context of relevant topics and cutting-edge research.

### **Pedagogical Approaches for RRI and NoS Teaching**

In each of the ten partner countries in the IRRESISTIBLE project, communities of learners developed thematic modules. These groups were comprised of school teachers, educational experts from universities, exhibition experts from museums and science centres and researchers from the respective thematic fields (Apotheker et al., 2017). There was no given standard procedure for module development within the project; moreover, the different communities of learners drew on existing material or prior experience and expertise, and followed the most promising approach respectively. Most groups developed their modules by attending to the scientific topic and its relevant socio-scientific issues. Subsequently, the RRI aspects were highlighted in the material, and augmented if necessary before the material was fully developed. Some of the communities, like the group from Portugal, worked the other way round: they started with the six RRI dimensions and subsequently wove the content into that frame. Although NoS teaching was not the explicit objective for the modules, the developers found many well-known NoS teaching approaches very apposite for addressing the RRI dimensions.



This way, 17 teaching modules were developed, covering various contemporary research topics like nanoscience, climate research, innovative materials for solar cells, geoengineering, and ocean research. (Modules available at <http://www.irresistible-project.eu/index.php/en/resources/teaching-modules>). All modules were tested by the teachers developing them and subsequently exchanged with other partner countries for another implementation.

The IRRESISTIBLE project built on the six aspects approach to characterize RRI as proposed by Sutcliffe (2011) and verbalized in a catchy way by the European Commission (2012). The two additional RRI aspects, Social Justice / Inclusion and Sustainability, were not explicitly integrated into the IRRESISTIBLE modules since they were added to the RRI framework after the module development took place (European Commission, 2015b). Those themes were, however, implicitly addressed within the dimensions Gender Equality and Ethics.

During the module development, two major challenges emerged. The first was to understand fully the concept of RRI and to adapt it meaningfully to the school level. The concept itself was written from a research perspective, i.e. looking at the aspects with a full understanding of how science works. This created some challenges, particularly for the teachers working in the communities of learners. A special workshop was organized to address this issue (Blonder et al., 2017) and to exchange ideas to form a shared understanding of RRI within the project. Another challenge was to find the pedagogical methods for RRI in science classes. In particular, the question of whether RRI should be taught explicitly or implicitly was hotly debated (cf. de Vocht et al., 2017). Explicit teaching may create a higher visibility of RRI for students, but with the risk of appearing as though it has been artificially set on top of the topic. Implicit teaching provides a close connection and natural integration to the subject, but with the danger of losing sight of RRI in the great diversity of the cutting-edge research topics. Several approaches were discussed, such as scenario-based learning, role-play or student-curated exhibits (Kampschulte & Parchmann, 2015), using both implicit and explicit approaches. In the communities of learners, very different environments, where students take active parts, discuss, judge, argue, value, and learn RRI while learning scientific phenomena, were created. For example, in the Turkish module discussing bacteria resistant to antibiotics, RRI was more or less integrated in the whole module. In the Dutch module discussing the difference between cow milk and mothers milk, RRI was introduced explicitly in the exploration phase. The RRI dimensions were introduced and linked to different aspects of the scientific knowledge in the module (Apotheker et al., 2017). Both approaches worked for the teachers.

Most typically, the integration of RRI was realized in the module activities addressing one RRI aspect specifically. For example, the most popular approach to integrate the dimension of Engagement was to use a role play: Making students take the roles of different societal actors and debate for example, the issues of nanoscience in order to learn about its complex societal connections. Such methods have been used successfully in NoS teaching when addressing aspects like Social Organizations and Interactions, Political Power Structures, and Financial Systems (Erduran & Dagher, 2014).

**Table 1** lists an example from the IRRESISTIBLE teaching modules for each RRI aspect, and adds the related NoS aspects in the last column. The table demonstrates how the instructional methods employed in IRRESISTIBLE to teach RRI closely resemble the approaches for teaching the socio-institutional dimensions of NoS (sections 2 and 4).

**Table 1.** Examples of integrating Responsible Research and Innovation (RRI) aspects in the teaching modules and their Nature of Science (NoS) equivalents.

RRI Aspect	Example from the teaching modules	NOS Aspects
Engagement	Students took the roles of stakeholders who deal with these issues as part of their everyday life. Roles were taken for a single discussion or through the whole module.	<ul style="list-style-type: none"> <li>• Social Organizations and Interactions</li> <li>• Political Power Structures</li> <li>• Financial Systems</li> </ul>
Gender Equality	Analysis of documentary videos or scientific articles to reflect gender distribution in research and subsequently discuss these issues.	<ul style="list-style-type: none"> <li>• Political Power Structures</li> <li>• Social Organizations and Interactions</li> </ul>
Science Education	Students train their practical scientific skills: designing and performing experiments, collecting and analysing data, interpreting and discussing findings.	<ul style="list-style-type: none"> <li>• All NoS teaching and learning, both cognitive-epistemic and socio-institutional aspects</li> </ul>
Open Access	To weigh up prospects and risks of a topic, students searched and used scientific articles. When hitting the pay wall for closed access publications, the topic of open access (in a broader sense) was discussed.	<ul style="list-style-type: none"> <li>• Social Certification and Dissemination</li> <li>• Professional Attitudes</li> </ul>
Ethics	Discussion on ethical standards, criteria, and the dilemmas associated with open-ended research. SWOT analysis to structure and sum up the results of the debate on benefits and limitations of novel technologies.	<ul style="list-style-type: none"> <li>• Scientific Ethos</li> <li>• Social Values of Science</li> <li>• Financial Systems</li> </ul>
Governance	Group work or group discussion based on a statement of a political group or a part of a regulatory act.	<ul style="list-style-type: none"> <li>• Social Certification and Dissemination</li> <li>• Social Organizations and Interactions</li> <li>• Political Power Structures</li> <li>• Financial Systems</li> </ul>

Although the most common approach was to develop activities focusing on one of the six RRI dimensions, some of the countries integrated all RRI aspects into a single activity: In two of the modules, the RRI dimensions were worked out in three consecutive lessons and then presented as one area in the final student-curated exhibition. In another module, a dice game served as tool for developing the RRI aspects. Students played with two dice: One die was labelled with the six RRI aspects on the sides, the other die had six scientific module-related terms. When throwing the dice, students always got a combination of an RRI aspect and a scientific term. Their task in the group was then to come up with an example where the aspects are connected. The game not only served as a tool to recapitulate and discuss the RRI dimensions, but also to find relevance for these aspects in (nanotechnology) research and everyday life. In addition, the game trained students in various other skills like communication, willingness to compromise, and teamwork.

The wide variety of activities to integrate the different RRI aspects in the teaching modules shows not only the creativity of the communities of learners, but also the educational adaptability of the RRI concept. As presented with the examples above (Table 1), integrating RRI through NoS teaching approaches seems feasible.

### Teachers' Attitudes about RRI Teaching

Since teachers play a make-or-break role in any curriculum innovation, we briefly discuss our findings on teachers' interests and concerns when adopting RRI in their teaching. Sixty-seven science teachers from all school levels and 10 European countries were surveyed during the first round of IRRESISTIBLE (de Vocht et al., 2017), and 180 teachers during the second round (de Vocht & Laherto, 2017). These surveys employed the Stages of Concern questionnaire (Hall, George & Rutherford, 1977; Liu & Huang, 2005) which was adopted in the first round and further developed in the second round (for full details of the instruments and analyses, see de Vocht & Laherto, 2017; de Vocht et al., 2017). The results showed that during the first round, teachers were mainly interested in finding information on RRI and learning about it. Teachers were also interested in collaborating with other teachers when adopting RRI. However, teachers voiced some concerns related to their personal ability to teach RRI and management of resources within already busy teaching schedules. These concerns were not resolved during the project, as the pre/post-survey comparison showed (de Vocht et al., 2017).

The larger sample in the second round allowed for a more thorough analysis using cluster analysis (de Vocht & Laherto, 2017). As in the first round, concerns and interests were first divided into different themes – or “stages of concern” (cf. Liu & Huang, 2005) – such as information, management and collaboration. The questionnaire items dealt with several types of concerns and interests, e.g. item “I am not competent in teaching RRI” addressed a more serious and intrinsic concern than item “I am concerned about not having enough opportunities to develop my RRI teaching”. The improved questionnaire also took into account the distinction between negative concerns (worries) and positive concerns (interests). The analysis employed multiple clustering methods. Both k-means cluster analysis and hierarchical cluster analysis with Ward's method resulted in four distinct clusters for the negative

concern items, and three clusters for positive concerns, i.e. interests. Profile types were identified using the concern clusters, whereas the interest clusters acted as a subcategories; for full information on the methods and results of the cluster analysis, see de Vocht and Laherto (2017). The major profile types were the “Carefree”, the “Pragmatic” and the “Uncertain”. The “Carefree” profile type had few concerns and a great deal of interest in adopting RRI in their teaching: they felt confident about their personal knowledge and skills in RRI, ability to manage RRI teaching in practice, and to improve their practices, to collaborate with other teachers, and to influence students in a positive way. The “Pragmatic” group was similar to the “Carefree”, but had significantly more concerns related to finding information about RRI and allocating teaching resources to it. Finally, the “Uncertain” group had major concerns related to their ability to teach RRI (de Vocht & Laherto, 2017).

The high number of “Uncertain” teachers calls for better conceptualization of RRI in the school context. Furthermore, when interpreting these results, one must keep in mind that the teachers in the IRRESISTIBLE project were forerunners and may not represent the average teacher. It is safe to say that if RRI is to be disseminated on a wider scale across Europe, more concerns are to be expected from teachers. Teaching innovations which originate from outside school typically face more opposition than innovations created by teachers and educators (de Vocht et al., 2017). Therefore, discussing RRI in the context of NoS, with which teachers are already more familiar, may facilitate the incorporation of RRI elements in science education.

In Turkey, a *Nano and Health* module was implemented by twenty-four science teachers (of biology, chemistry, physics) at 19 schools as an extra-curricular activity for about 12 weeks. After completing the module, teachers were given a questionnaire including 16 open-ended questions asking to evaluate module implementation in terms of student gains of content knowledge and skills. Specifically, one of the questions in the questionnaire was; “Please indicate three RRI-related objectives you think that your students attained by completing the *Nano and Health* module.”

For this question, a total of 59 responses were obtained from the teachers. These responses were coded through inductive content analysis, and analysed according to the meaningful categories emerged. About 20% percent of the responses were coded by another researcher, and then discussed until reaching full interrater agreement. According to the teachers, the module helped their students raise awareness about RRI (41%), learn about RRI (39%), take action for RRI (10%), integrate RRI into nanotechnology (7%), and develop beliefs about RRI. The analysis and results were described in detail elsewhere (Akaygun & Adadan, 2017), and here just briefly discussed in context of RRI and NoS teaching.

The category “learn about RRI” can be associated with the cognitive-epistemic element of NoS (Irzik & Nola, 2014), dealing with understanding concepts, models, laws and theories. Teachers suggested that the greatest number of students (41%) gained an “awareness” of RRI. This category matches well with the Scientific Ethos and Social Values components of science as a social institution, since teachers indicated that students started to value ethics, honesty, openness, critical attitude, gender equality, and universalism. Few teachers (10%) argued that their students learnt to “take action” regarding RRI. This gain can also be associated with the Social Values components of Science as a Social institution: as the students develop values like autonomy and social utility, they could start engaging in societal issues and taking action for RRI. Furthermore, very few teachers (7%) indicated that students learned “integrating RRI to the context”, which can be linked to learning the socio-institutional dimensions of NoS (Erduran & Dagher, 2014). In other words, very few teachers thought that their students could see RRI in a broader perspective, consider the role of larger systems wherein RRI is embedded and effectively functions as a part of the system. Finally, very few teachers (4%) indicated that their students developed “beliefs about RRI”, which can also be associated with the Scientific Ethos component because students develop critical attitudes, universalism, and respect for RRI. The reason for having only a small percentage of teachers acknowledging students’ gains regarding “action”, “integration of RRI” and “beliefs” could indicate that these gains are higher order because they require more effort and experience. The gains regarding “knowledge” and “awareness” could be considered to be lower order as they were fundamental, relatively easier, and hence achieved by the majority. This small analysis (for further details, see Akaygun & Adadan, 2017) showed that there seems to be a connection between students’ gains in RRI and NoS due to the similarities in their nature.

One of the more debated questions during the IRRESISTIBLE project was whether RRI should be taught implicitly or explicitly. This item divided teachers roughly in half during both rounds of project (de Vocht & Laherto, 2017; de Vocht et al., 2017). This issue, similar to the one discussed in the previous section concerning the approaches adopted in the modules, is further discussed in the concluding section.

Furthermore, an additional instrument to analyse teachers’ attitudes about RRI was developed and administered to teachers participating in the IRRESISTIBLE project (Blonder et al., 2017). The questionnaire, including two items for each RRI dimension, enabled the researchers to examine the changes in the teachers’ attitudes about RRI. The process of teacher professional development in the project, that included a direct explicit teaching of the RRI dimensions, led to a positive, statistically significant change in teachers’ attitudes to RRI as a general construct and for four of its dimensions separately (results for the dimensions of engagement and gender equality were not statistically significant).

The questionnaire included another part in which the teachers were asked to rate the responsibility for RRI of different stakeholders (scientists, educators, environmental organizations, NGOs, consumers, businesses, the printed and electronic media, the government, and academic institutions) in the real world and in an ideal world (for further details of the questionnaire, see Blonder et al., 2017). An interesting aspect detected from this part of the questionnaire was teachers' perspectives regarding their own role in promoting RRI. When the teachers were asked "In an ideal world, what degree of responsibility should each specific group take for RRI (for the consequences of research and innovation in society and the environment)?" they gave it a very low grade (less than 2, in a scale of 1-5) for educators. This grade remained low even after the teachers participated in the IRRESISTIBLE project (Blonder et al., 2017). This result shows that although the teachers developed positive attitudes about the RRI construct they still do not quite recognize their role and their responsibility as science teachers to promote RRI. The finding highlights the need to contextualize RRI better in current practices of science education, which was the aim of the present paper.

## CONCLUSIONS

Both the concept of RRI (European Commission, 2012) and the recent recommendations for school science (European Commission, 2015) push European science education towards addressing science as a socio-institutional system. It is likely that the concept of responsibility, with its dimensions specified by the concept RRI, will be at the core of European science education in the next decades. This trend will arguably highlight and contribute to the modern conceptions of Nature of Science (NoS) in science classrooms.

While RRI has so far mostly remained a concern of academia, the concept is gradually entering school education also. For example, in some European systems, school teachers can acquire additional credit for adopting RRI and embedding it in their practice (Kearney, 2016). This is a worthwhile strategy, since teachers play a key role in the diffusion of RRI in schools (de Vocht et al., 2017). Our experiences, however, show that contextualising RRI in science classrooms is not an easy task. We assume that connecting the concept of RRI into existing approaches and trends – such as NoS teaching – would help teachers, curriculum developers and educationists in incorporating RRI in the curriculum and in finding suitable pedagogical approaches for it.

The conceptual analysis carried out in this paper is comparable to that undertaken by Blonder et al. (2016) about the connections of RRI to another central framework of science education, the Socio-Scientific Issues (SSIs). They pointed out that SSIs fit well together with the RRI obligations of the scientists to contribute to the field of science education and public engagement. Blonder et al. (2016) concluded that most of the RRI dimensions are at least mentioned in the SSI literature, although not in a systematic way. In the present paper we highlighted connections between RRI and NoS that are at least as strong, and argue that relatively well-established NoS teaching also provides an excellent platform to incorporate RRI in classrooms. Our concept analysis and practical examples show that the socio-institutional NoS activities, developed by the science education community, align especially well with the RRI aims, i.e. promoting a culture of responsibility, participative inquiry and debate among different stakeholders. This overlap makes it possible to employ the recommendations and practical applications of the Expanded Family Resemblance Approach (Erduran & Dagher, 2014) to address RRI in classrooms.

Yet, further research is needed to fully operationalize RRI in science education and to find assessment criteria for it. Which values of science should be addressed in science education, and how? What kind of learning objectives should be set for RRI (cf. Heras & Ruiz-Mallén, 2017)? Within the IRRESISTIBLE project, formulating learning goals was found to be difficult. RRI entails a specific emphasis on deep engagement between the public and different societal actors in the processes of research and innovation, aiming at promoting the responsiveness, ethical acceptability, sustainability and societal desirability of these processes. These societal concerns bring a new layer to current NoS approaches. For evaluating RRI learning, well-established NoS questionnaires are a good start, but not enough.

In the approaches developed for RRI teaching in the IRRESISTIBLE project, another recurrent question was if the RRI dimensions should be explicit or implicit in teaching and learning (Apotheker et al., 2017; de Vocht et al., 2017). This debate resembles the dispute on whether NoS should be taught explicitly or implicitly (Lederman, 2007). However, RRI is a far less neutral and more formative and value-laden concept than NoS. RRI teaching, thereby, has to address a further question: should teachers teach RRI as a normative set of values, or should they support students in their own meaning-making and to come up with their own set of values considering the societal aspects of research and innovation? In some IRRESISTIBLE teaching modules, RRI was foregrounded, in some modules backgrounded. Some communities of learners chose to teach RRI explicitly as a normative set of key points, for example making students study the EU documents and prepare presentations about each RRI key-point as such. Some communities of learners combined RRI with a context in an implicit way, implying that students should be encouraged to discuss and come up with a diversity of viewpoints and reasoning regarding the values and aims of the society.

Such classroom discourse could lead RRI teaching towards the socio-empirical version of RRI (Ruggiu, 2015). One way to apply this in teaching, as solved in several IRRESISTIBLE modules, is to present students with an RRI-related conflict of interest, and let students assume different societal roles. In this way, students can create a dynamic view of how the RRI-related values of our society can be formed. Such a socio-empirical way to teach RRI is not possible if RRI is presented explicitly to the students as a set of key points. Teachers, however, can use the key points as a loose guide when planning their lessons, while not presenting them directly in the teaching-learning content.

## ACKNOWLEDGEMENT

The empirical results originate from the EU funded project IRRESISTIBLE (FP7-SCIENCE-IN-SOCIETY – 612367). We thank all the project partners from ten European universities who provided valuable feedback for the development of the instruments, and took care of the local data collection. We are grateful to all teachers and their students in all ten countries for participating in the project and expressing their views in the questionnaires.

## REFERENCES

- Akaygun, S., & Adadan, E. (2017, May). Teaching Nanotechnology as an Extracurricular Activity: Views of Teachers. Paper presented at the *International Conference in Education of Mathematics, Science and Technology (ICEMST)*, Aydin, Turkey.
- Allchin, D. (2011). Evaluating Knowledge of the Nature of (Whole) Science. *Science Education*, 95(3), 518-542. <https://doi.org/10.1002/sce.20432>
- Apotheker, J., Blonder, R., Akaygun, S., Reis, P., Kampschulte, L., & Laherto, A. (2017). Responsible Research and Innovation in secondary school science classrooms: experiences from the project Irresistible. *Pure and Applied Chemistry*, 89(2), 211-219. <https://doi.org/10.1515/pac-2016-0817>
- Bardone, E., Burget, M., Saage, K., & Taaler, M. (2017). Making Sense of Responsible Research and Innovation in Science Education through Inquiry-based Learning. Examples from the Field. *Science Education International*, 28(4), 293-304.
- Blonder, R., Rap, S., Zemler, E., & Rosenfeld, S., (2017). Assessing attitudes about responsible research and innovation (RRI): the development and use of a questionnaire. *Sisyphus Journal of Education*, 5(3), 122-156.
- Blonder, R., Zemler, E., & Rosenfeld, S. (2016). The story of lead: a context for learning about responsible research and innovation (RRI) in the chemistry classroom. *Chemistry Education Research and Practice*, 17(4), 1145-1155. <https://doi.org/10.1039/C6RP00177G>
- Burguet, M., Bardone, E., & Pedaste, M. (2017). Definitions and conceptual dimensions of responsible research and innovation: A literature review. *Science and Engineering Ethics*, 23(1), 1-19. <https://doi.org/10.1007/s11948-016-9782-1>
- de Vocht, M., & Laherto, A. (2017). Profiling teachers based on their professional attitudes towards teaching responsible research and innovation. *European Journal of Science and Mathematics Education*, 5(3), 271-284.
- de Vocht, M., Laherto, A., & Parchmann, I. (2017). Exploring teachers' concerns about bringing Responsible Research and Innovation to European science classrooms. *Journal of Science Teacher Education*, 28(4), pp. 326-346. <https://doi.org/10.1080/1046560X.2017.1343602>
- Elby, A., & Hammer, D. (2001). On the substance of a sophisticated epistemology. *Science Education*, 85(5), 554-567. <https://doi.org/10.1002/sce.1023>
- Erduran, S., & Dagher, Z. (2014). *Reconceptualizing the Nature of Science for Science Education: Scientific Knowledge, Practices and Other Family Categories*. Dordrecht: Springer.
- European Commission (2007). *Science Education Now: A Renewed Pedagogy for the Future of Europe. Report to the European Commission of the High Level Group on Science Education*. Luxembourg: Publications Office of the European Union.
- European Commission (2012). *Responsible research and innovation – Europe's ability to respond to societal challenges*. Luxembourg: Publications Office of the European Union.
- European Commission (2015). *Science Education for Responsible Citizenship. Report to the European Commission of the expert group on science education*. Luxembourg: Publications Office of the European Union.
- European Commission (2015b). *Indicators for promoting and monitoring Responsible Research and Innovation. Report from the Expert Group on Policy Indicators for Responsible Research and Innovation*. Luxembourg: Publications Office of the European Union.

- Hall, G. E., George, A. A., & Rutherford, W. L. (1977). *Measuring stages of concern about the innovation: a manual for use of the SoC questionnaire*. Washington, DC: National Inst. of Education (DHEW).
- Heras, M., & Ruiz-Mallén, I. (2017) Responsible research and innovation indicators for science education assessment: how to measure the impact? *International Journal of Science Education*, 39(18), 2482-2507. <https://doi.org/10.1080/09500693.2017.1392643>
- Irzik, G., & Nola, R. (2011). A family resemblance approach to the nature of science for science education. *Science & Education*, 20, 591-607. <https://doi.org/10.1007/s11191-010-9293-4>
- Irzik, G., & Nola, R. (2014). New directions for nature of science research. In M. Matthews (Ed.), *International handbook of research in history, philosophy and science teaching* (pp. 999-1021). Dordrecht, The Netherlands: Springer. [https://doi.org/10.1007/978-94-007-7654-8\\_30](https://doi.org/10.1007/978-94-007-7654-8_30)
- Kampschulte, L., & Parchmann, I. (2015). The student-curated exhibition - A new approach to getting in touch with science. *LUMAT*, 3(4), 462-482.
- Kárpáti, A., & Király, A. (2016, June). Creating a socially sensitive learning environment for science education: The SSIBL framework. In: Teixeira, A. M., Szűcs, A., & Lázár, I. (Eds.), *Re-imagining learning scenarios. Paper presented at the EDEN 2016 Annual Conference*, Budapest (pp. 599-608).
- Kearney, C. (2016). Efforts to Increase Students' Interest in Pursuing Mathematics, Science and Technology Studies and Careers. *National Measures taken by 30 Countries - 2015 Report*. Brussels: European Schoolnet.
- Lederman, N. G. (2007). Nature of science: Past, present, and future. In S. K. Abell & N. G. Lederman (Eds.), *Handbook of research on science education*. Mahwah, NJ: Erlbaum, 831-879.
- Lederman, N. G., & Lederman, J. S. (2014). Research on Teaching and Learning of Nature of Science. In N. G. Lederman & S. K. Abell (Eds.), *Handbook of Research on Science Education, Volume II* (pp. 600-620). New York, NY: Routledge.
- Liu, Y., & Huang, C. (2005). Concerns of teachers about technology integration in the USA. *European Journal of Teacher Education*, 28(1), 35-47. <https://doi.org/10.1080/02619760500039928>
- McComas, W., & Olson, J. (1998). The Nature of Science in Science Education. *Science and Education*, 7(6), 511-523. <https://doi.org/10.1023/A:1008642510402>
- Owen, R., Macnaghten, P., & Stilgoe, J. (2012). Responsible research and innovation: from science in society to science for society, with society. *Science and Public Policy*, 39, 751-760. <https://doi.org/10.1093/scipol/scs093>
- Roberts, D. A. (2007). Scientific literacy/Science literacy. In S. K. Abell, & N. G. Lederman (Eds.), *Handbook of research on science education* (pp. 729-780). Mahwah, NJ: Lawrence Erlbaum Associates.
- Roberts, D. A., & Bybee, R. W. (2014). Scientific literacy, science literacy, science education. In N. G. Lederman & S. K. Abell (Eds.), *Research on science education, Vol. II* (pp. 545-558). New York: Routledge.
- Rudolph, J. L. (2000). Reconsidering the 'Nature of Science' as a Curriculum Component. *Journal of Curriculum Studies*, 32(3), 403-419. <https://doi.org/10.1080/002202700182628>
- Ruggiu, D. (2015). Anchoring European governance: Two versions of responsible research and innovation and EU fundamental rights as 'normative anchor points'. *Nanoethics*, 9, 217-235. <https://doi.org/10.1007/s11569-015-0240-3>
- Sadler, T. D., Barab, S. A., & Scott, B. (2007). What do students gain by engaging in socioscientific inquiry? *Research in Science Education*, 37(4), 371-391. <https://doi.org/10.1007/s11165-006-9030-9>
- Stilgoe, J., Owen, R., & Macnaghten, P. (2013). Developing a framework for responsible innovation. *Research Policy*, 42(9), 1568-1580. <https://doi.org/10.1016/j.respol.2013.05.008>
- Sutcliffe, H. (2011). A report on responsible research and innovation. MATTER / European Commission. Retrieved on 06.07.2017 from [https://ec.europa.eu/research/science-society/document\\_library/pdf\\_06/rri-report-hilary-sutcliffe\\_en.pdf](https://ec.europa.eu/research/science-society/document_library/pdf_06/rri-report-hilary-sutcliffe_en.pdf)
- von Schomberg, R. (2013). A Vision of Responsible Research and Innovation. In R. Owen, J. Bessant, & M. Heintz (Eds.), *Responsible Innovation: Managing the Responsible Emergence of Science and Innovation in Society*. Chichester, UK: John Wiley & Sons. <https://doi.org/10.1002/9781118551424.ch3>
- Wenning, C. (2006). Assessing nature-of-science literacy as one component of scientific literacy. *Journal of Physics Teacher Education Online*, 3(4), 3-14.



# Application of the Complementarities of Two Theories, APOS and OSA, for the Analysis of the University Students' Understanding on the Graph of the Function and its Derivative

Vahid Borji <sup>1\*</sup>, Vicenç Font <sup>2</sup>, Hassan Alamolhodaei <sup>1</sup>, Alicia Sánchez <sup>2</sup>

<sup>1</sup> Ferdowsi University of Mashhad, Mashhad, IRAN

<sup>2</sup> University of Barcelona, Barcelona, SPAIN

Received 3 November 2017 • Revised 20 February 2018 • Accepted 12 March 2018

## ABSTRACT

The goal of this paper is the combined use of two theories, APOS and OSA, for the analysis of the university students' understanding on the graph of the function and its derivative. For this, we study the students' understanding to solve one graphing problem in relation to the first derivative and characterize their schemas in terms of levels (intra, inter and trans) of development of the schema for sketching  $f'$  when given the graph  $f$ . We present a multiple case study in which 14 students of the first course of Calculus in one university of Iran participated voluntarily. Results show that most of the students in our study had major problems in developing mental constructions and doing the practical work needed to solve the problem, particularly those mental constructions that have to be made to calculate the derivative at the critical points and to determine the speed of the variation of the inclination of the tangent lines to  $f$ , which is why most of them have constructed a schema at the intra level of development of the schema for sketching  $f'$  when given the graph  $f$ . We finish with some final conclusions.

**Keywords:** students' graphical understanding, the concept of derivative, APOS theory, OSA theory, mathematical object

## INTRODUCTION

In Iran, teaching of Calculus in the first courses of university is usually based on textbooks that place the emphasis on algebraic representations and disregard graphical representation (Borji & Alamolhodaei, 2016a, 2016b). This is a phenomenon that also occurs in other countries (Park, 2015; Sánchez-Matamoros, García & Llinares, 2008). For this reason, most of the students can solve a routine differentiation problem easily but have no correct conceptual understanding of derivative's graphical representation and the correlation between the algebraic and graphical representation (Baker, Cooley, & Trigueros, 2000). For instance, some of the students or even teachers do not know the correlation between the slope of the tangent line and difference quotient limit ( $\lim_{x \rightarrow a} \frac{f(x)-f(a)}{x-a}$ ) (Badillo, Azcárate, & Font, 2011; Özmantar, Akkoç, Bingölbali, Demir, & Ergene, 2010; Sahin, Erbas, & Yenmez, 2015; Sánchez-Matamoros, Fernández, & Llinares, 2015).

Recent research papers (Badillo et al., 2011; Drijvers, Godino, Font, & Trouche, 2013; Font, Trigueros, Badillo, & Rubio, 2016; Fuentealba, Sánchez-Matamoros, Badillo, & Trigueros, 2017; Mackie, & Court, 2002; Pino-Fan, Godino & Font, 2011; Pino-Fan, Font, Gordillo, Larios, & Breda, 2017; Robles, Telechea & Font, 2014; Tall, 2013; Tiwari, 2007) on learning and teaching of Calculus have revealed the complexity of the fundamental mathematical objects in this area of mathematics (derivative, integral, etc.) and the need to teach different partial meanings of these objects and connect them to each other for their understanding. In order to do this, the use of different representations and translations between them is fundamental (Font, 2000). One of the approaches that try to characterize this complexity is the APOS theory. In the APOS (Fuentealba et al., 2017) the type of understanding that allows to relate different partial meanings of a mathematical object is characterized in terms of thematization of schema and in

#### Contribution of this paper to the literature

- Our goal in this study is to investigate, in terms of levels (intra, inter and trans) of development of the schema, students' understanding to solve a problem, where the graph of a function includes some critical points, and it asks to draw the graph of  $f'$ .
- To achieve this goal, the use of APOS is complemented by the OSA theoretical tools to better characterize the mathematical activity performed by the student and to be able to infer their understanding of the problem.
- The results show that most of the students in our study had major problems in developing mental constructions and performing the practical work needed to calculate the derivative at the critical points.

terms of levels (intra, inter and trans) of development of this schema. For this reason and given that there is little research on this topic at international level, particularly in Iran, our goal is to investigate students' understanding to solve one problem, where the graph of a function includes some critical points and it asks to draw the graph of  $f'$ , and we characterize students' schema in terms of levels (intra, inter and trans) of development of the schema for sketching  $f'$  when given the graph  $f$ . To achieve this goal, in this paper the way of understanding APOS comprehension is complemented by the use of OSA theoretical tools to better characterize the mathematical activity performed by the student and to be able to infer their understanding of the problem. The use of tools of OSA is incorporated because we consider, according to Font et al. (2016), that a networking of APOS and OSA provides tools to explain the difficulties associated with the learning of specific concepts.

## LITERATURE REVIEW

Many studies (e. g. Lauten, Graham, & Ferrini-Mundy, 1994; Leinhardt, Zaslavsky, & Stein, 1990; Tall, & Vinner, 1981) explain that student difficulties in dealing with a function given in graphical form may be a result of traditional instructional methods. Some articles (Orton, 1983; Selden, Selden, & Mason, 1994) report how even students who performed very well on routine calculus problems found great difficulty and had little or no success in dealing with graphical problems.

Some researchers (Amit, & Vinner, 1990; Asiala, Cotrill, Dubinsky, & Schwingendorf, 1997; Dominguez, Barniol, & Zavala, 2017) discuss specific difficulties that students have with the graphical representation of the derivative. These authors explain some difficulties students have with basic calculus concepts. They explain that some students equate the equation for the line tangent to the graph of a function at a given point with the derivative of the function.

Ferrini-Mundy and Graham (1994) discuss about students' desire to find an equation for a function given only graphically before attempting to plot the graph of the derivative function. Zandieh (2000) described the relation between the derivative and original function as a process of passing through many input values and determining an output value for each of them given by the limit of the difference quotient, and found that only a few of the students she considered included some explanation of covariance. Oehrtman, Carlson, and Thompson (2008) reported that their students were often unable to realize the relation between derivative and original function in the graphical form. Nemirovsky and Rubin (1992) investigated students' understanding about derivative while they worked with graphs, and found that many students sketched a graph for the derivative similar to the original function graph without appreciating the relation between a function and the derivative over the intervals.

In some of the investigations cited (Asiala et al., 1997; Borji & Voskoglou, 2016, 2017) APOS is used as a theoretical framework. In this approach, many researches use the triad (intra, inter and trans) to investigate students' understanding of different concepts of calculus, in particular the derivative. Badillo et al. (2011) report the level of understanding of the relation between  $f'(a)$  and  $f'(x)$  among some calculus teachers. The teachers answered to a questionnaire about their understanding of  $f'(a)$  and  $f'(x)$ . The authors reported how the comprehension of  $f'(a)$  and  $f'(x)$  can be related to the underlying structure of both graphic and algebraic schemes. Clark et al. (1997) used the triad to interpret the stages of understanding of the chain rule schema. Baker et al. (2000) introduced the interaction of two schemas. The authors used the triad to describe student understanding when given a derivative graphing problem. Garcia, Llinares, and Sánchez-Matamoros (2011) reported on different structures of the derivative schema of the students that were considered to be at the trans. They explained that there are different structures in the schema because of the consciousness in which students use the relations between a function and derivative of the function. Fuentealba et al. (2017) used APOS theory and the configuration of the derivative concept to focus on the analysis of students' answers to a sequence of tasks of the derivative. They suggested that thematizing the derivative schema is difficult to achieve and observed delicate differences in responses given by the students who succeeded, indicating differences in the relations between the successive derivatives of a function.

In the framework of OSA, research has been carried out on the emergence of mathematical objects of differential and integral calculus. In Font and Contreras (2008) it is argued that in order to understand a definition of derivative function, a hypothetical student has to put in operation (plausibly) several semiotic functions. Font (2000, 2005) concluded that in the process of calculating  $f'$  three phases must be considered: (1) Translations between the different forms of representing  $f$ ; (2) the transition from a form of representation of  $f$  to a form of representation of  $f'$ ; and, (3) translations and conversions between the different forms of representing  $f'$ . In Font (2000) it is analyzed the semiotic complexity of three different ways of introducing the derivative function: (1) Definition by limits; (2) finding a condition that all tangents meet and, from that, calculating said derivative function; and, (3) calculating it by means of the values of the derivative at various points, given in a table.

Currently in the Didactics of Mathematics there is a tendency to find possible relationships between different theories and compare them. In particular, possible connections between the APOS and the OSA are recently on the focus of interest. This is related to an apparent need for APOS development with contributions from semiotic theories (Badillo et al., 2011; Font, Malaspina, Giménez and Wilhelmi, 2011; Font, Montiel, Vidakovic and Wilhelmi, 2011; Trigueros & Martínez-Planell, 2010) and the fact that in theories (APOS & OSA) an important cognitive component intervenes.

The starting point to search for connections between the OSA and APOS theory is the inquiry into the use of the notion of “mathematical object” in both theories (Font, Badillo, Trigueros, & Rubio, 2012; Font et al., 2016). Two relevant aspects to address this issue are: (1) the interest that has had for mathematics education questions about the nature of mathematical objects, their various types, the processes of constitution and forms of participation in mathematical activity and (2) the fact that OSA and APOS are examples of a group of theories that use the term *mathematical object* as a relevant construct of its theoretical framework. To materialize this dialogue, in Font et al. (2016) a Genetic Decomposition (GD) was developed from APOS for the concept of derivative that was later analyzed from the point of view of OSA, in order to unravel some aspects that are implicit in the mechanisms of APOS related to the emergence of objects, and thus understand better its complexity and the possible relation between mental constructions. Results of this networking showed some commonalities and some links between these theories and signaled the complementary nature of their constructs.

In this article, we analyze students’ understanding to solve one graphing problem in relation to the first derivative and characterize their schemas in terms of levels (intra, inter and trans) of development of the schema. As it has been said in the literature review, many studies have explained that it is hard for students to understand the construction of the derivative function in relation to the original function in the graphical representation. With the aim of having a better comprehension of the students’s problems, we will use two lens: APOS and OSA that have already been used in other investigations (Badillo et al., 2011; Font, Badillo, Trigueros, & Rubio, 2012; Font, Malaspina, Giménez, & Wilhelmi, 2011; Font, Montiel, Vidakovic & Wilhelmi, 2011; Font et al., 2016; Font, Trigueros, Badillo & Rubio, 2012; Trigueros & Martínez-Planell, 2010).

## THEORETICAL FRAMEWORK

In this section, we explain the two theoretical frameworks used (APOS and OSA) and the relationship between them.

### APOS

The APOS theory characterizes the mathematical knowledge of a student as their tendency to respond to problematic mathematical situations by reflecting on problems and their solutions within a social context and the construction or reconstruction of actions, processes and objects, organizing them into schemas to deal with this situation (Dubinsky, & McDonald, 2001). APOS is an acronym for these constructs (Action, Process, Object and Schema). A concept is first conceived as an *Action*, that is, as an externally directed transformation of a previously conceived *Object* (or *Objects*). An action is external in the sense that each step of the transformation needs to be performed explicitly and instructed by external guidance; additionally, each step operates the next, that is, the steps of the Action cannot be imagined and none can be skipped. When an action is repeated and the student reflects on it, this action may be interiorized into a *Process*. At this conception, the student may imagine taking the action and may anticipate its result without having to explicitly do the action. When they need to do transformations on these processes, the student encapsulates them into *Objects* and now can use actions on these newly constructed entities. A *Schema* is constructed as a coherent collection of Actions, Processes, Objects, and other Schemas, and connections among these constructs.

Schemas develop as connections between new and previous actions, processes, objects and other schemas. Their development may be explained by three stages that Piaget and García (1983) mentioned as the “triad”: Intra, inter and trans. At intra level, the newly constructed object is present, together with other objects and processes, but the individual is not aware of the connections that might exist between them. At inter level, actions and processes

between objects are constructed so that the recognition of relations between processes and objects, and transformations between them are starting to be made. Trans level is identified by being conscious of the complete formation and being able to decide whether a special situation can be resolved by this schema (Arnon et al., 2014).

In APOS, objects emerge as a result of two mechanisms: Encapsulation and Thematization. Encapsulation is a mechanism based on reflective abstraction. It refers to the possibility of thinking of a process as something complete and being able to characterize it and study its properties. Through encapsulation, abstract notions are conceived as objects having properties and various representations. Thematization involves the possibility of thinking the schema (or several) as a whole, to act or make transformations about it and study its properties. It also involves the possibility of dissecting, analyzing, examining its parts and re-composing it as a whole. The encapsulation of processes into objects and especially the thematization of a schema (or several) into an object (as well as its reverse mechanism) are related to complexity of the mathematical objects and the necessary articulation of the elements in which this complexity bursts.

APOS theory includes, as part of its application to research and teaching, a general model describing a possible way to construct the concept or topic of interest. This hypothetical model is called the Genetic Decomposition (GD) which includes a theoretical analysis of the actions, processes, objects, and schemas that a learner may construct in order to learn a certain mathematical concept. It is used to design research and instructional methods. The genetic decomposition of a mathematical topic is not unique and, in a certain way, it is linked to the instructional context for which it is constructed.

## OSA

The OSA is a theory that describes the mathematical activity from an institutional and personal point of view. In this theory, it is important to consider the objects involved in such activity and the semiotic relations between them (Breda, Pino-Fan, & Font, 2017; Font, Godino, & Gallardo, 2013; Rondero & Font, 2015). In OSA the mathematical activity can be modelled in terms of configuration of primary objects and processes that appear during the practice. A mathematical practice is considered in this theory as a sequence of actions, controlled by institutionally accepted rules, oriented towards an objective (usually solving a problem). In this theory the word 'object' is used in a big sense to refer to anything which is susceptible to be considered as an entity which is, in some way, included in mathematical practice and can be recognized as a unit. E. g., when assessing a problem solving practice, we can describe the use of different languages (graphic, symbolic, verbal ...). These languages are the ostensive part of a set of definitions, procedures and propositions that are involved in argumentation and justification of the problem solution. Problems, languages, definitions, procedures, propositions and arguments are used as objects, the six mathematical primary objects. Connected together they form configurations of primary objects. Configuration of objects in OSA can be seen both from a personal (cognitive) and from an institutional (epistemic) view. In the following lines we give more explanations about primary objects.

Language: Terms, expressions, notations, graphs, etc. in their various registers (written, oral, gestural, etc.).

Problems: Extra-mathematical applications, tasks, exercises, examples, etc.

Concepts/definitions: Introduced by means of definitions or descriptions, explicit or otherwise (straight line, point, number, mean, function, etc.).

Propositions: Statements about concepts, etc.

Procedures: Algorithms, operations, techniques of calculation, etc.

Arguments: Statements used to validate or explain the propositions and procedures, whether deductive or of another kind.

## Relation between APOS-OSA

A relation between some of the principal aspects of both theories is explained as follows (Font et al., 2016).

### *Action versus practice*

The terms of action (in APOS) and practice (in OSA) are complementary. In APOS an action is a transformation of mathematical objects that is made by a student based on some explicit algorithms and is observed by the subject as externally. In the OSA a practice is considered as a series of mathematical actions controlled by rules. The set of these rules forming the practice is categorized into types of primary objects. A difference between action in APOS and practice in OSA is that actions are mental constructions in the mind of an individual while practice in OSA is a collection of actions based on rules in the community.

### *Process versus procedure*

In APOS when the individual reflects on the action and constructs an internal operation that performs the same transformation, then we say that the action has been interiorized to a process. In OSA procedures are assumed to be rules about how to use mathematical objects. In OSA a practice is understood as a collection of mathematical actions made by rules that can be considered as different types of primary objects. One of these objects is the procedure, which is a rule of steps to carry out the practice, or a part of the practice. A procedure can also be considered complementary to a process in APOS when an individual shows to have interiorized mental actions and is aware of the result of the process.

### *Encapsulation versus primary object*

Encapsulation occurs when an individual applies an Action to a Process, that is, sees a dynamic structure (Process) as a static structure to which Actions can be applied. The result of encapsulation of a process is a mental object. From the perspective of OSA, encapsulation makes a double change in nature. On the one hand, from process to object which is a primary object based on OSA. On the other hand, encapsulation produces a change in the nature of the mathematical object associated to the cognitive object, since there is often a change from a procedure to a definition.

### *Cognitive configuration versus schema*

The terms of *cognitive configuration* in OSA and *schema* in APOS can be considered as complementary. A schema is a coherent set of actions, processes, objects, and other schemas that are related in the student's mind. A schema is coherent in the sense that given a problem situation, the student has an explicit or implicit path of deciding if the problem falls within this schema. In OSA the notion of cognitive configuration is a tool for explaining the objects involved and emerging from personal practices, and therefore, to explain the subject's knowledge, understanding and skills in the learning process. A cognitive configuration may reveal the complexity of a particular task linked to a schema. In fact, schema and cognitive configuration are different but complementary. A cognitive configuration is connected to a specific task, whereas a schema is related to types of tasks.

## METHODOLOGY

This research is a multiple case study in which 14 students participated voluntarily. The freshman students were enrolled in Electrical Engineering, Mathematics, and Physics at one of Iran's universities. All of them had completed a Calculus 1 course (single-variable calculus) in the same semester. Their textbook was Stewart Calculus, 2010. All students participated voluntarily in our research, at the end of which they received rewards of appreciation. The time interval between the end of their Calculus course and the interviews was approximately one month.

The methodology consists of the following steps: First, we posed one problem where the graph of a function includes some critical points and asked the students to draw the graph of  $f'$  function and collected the students' solutions. Second, we analyzed the mathematical activity following the methodology of onto-semiotic analysis (Pino-Fan, Godino, & Font, 2018), which consists of the analysis of mathematical practices and then considering the mathematical primary objects that were activated during these practices. Third, we made a genetic decomposition based on APOS theory. Our genetic decomposition describes the mental constructions that might be needed when students use the objects described in the second phase to solve these type of problems (this GD has been triangulated by two APOS experts). Fourth, we made the transcripts of the resolution of the task. Fifth, we analyzed the transcripts to determine the practices, the objects, and mental constructions of the GD and we assigned a level of development (intra, inter or trans) of the schema for sketching  $f'$  when given the graph of  $f$ .

These steps include an interview with each participating student, in which they were asked about some aspects of their written answers. Therefore, two instruments were used for data collection: an interview and a questionnaire with a complex task. It is consistent with the methodology required by the theoretical framework of APOS.

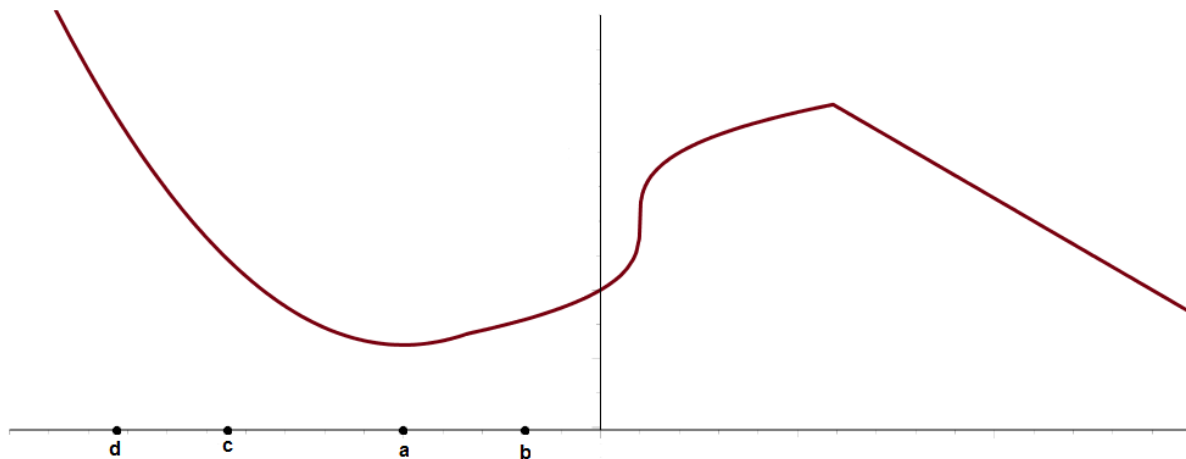
### **First step: The Problem**

Task: For the function  $f$  whose graph is given,

1. Arrange the following numbers in increasing order and explain your reasoning:

$$f'(a), f'(b), f'(c), f'(d)$$

2. State, with reasons, where the function  $f$  is not differentiable.
3. Sketch the graph of  $f'$ .



We gave the students a graph of the continuous function  $f$  that includes three critical points and asked them to answer the three questions. The main focus of our research was on question 3, sketching the graph of  $f'$  from the graph of  $f$ , and we only wrote students' transcriptions of this question in this research. However, whenever it was necessary, we have considered students' responses to questions 1 and 2. It should be noted that in the context of the course where this problem was proposed, the second question meant finding the points at which  $f'(x_0)$  does not exist. The data has been collected through worksheets, which contain the problem statement and its resolution (usually a graph). **Figure 1** is an example of an answer to question 3.

In what follows, we show more information about the relation between the task and the theoretical framework and the way the data was analyzed and how we arrived to the results. The students answered a graphical question about sketching the graph  $f'$  when given the graph  $f$  and after it, each of them explained their thinking processes. The interviewers were two of the authors of this article. The interviews were recorded as videos. Afterwards, we transcribed the video-files and collected students' sheets. The question designed in this study is complex because it required the student to use actions, processes, objects, and schemas (in the framework of APOS) and also practices and primary objects (in the framework of OSA) in order to sketch the graph of  $f'$  from seeing the graph of  $f$ . For this reason, we described the primary objects, based on OSA, and the mental constructions, based on APOS, that a student might make to develop her or his understanding of the question, which allowed us to determine different levels of development of the schema (intra, inter and trans). In our analysis of students' responses, we used these theoretical tools to characterize students' understanding in terms of the development of their schemas (intra, inter and trans).

### Second step: A look from the OSA

We make an a priori analysis of the mathematical activity to solve the problem in terms of practices performed and objects, based on OSA theory.

#### Practice

- 1) Read the task.
- 2) Write a text with one argumentation for the questions 1 and 2.
- 3) Sketch a graph of  $f'$ .

#### Epistemic configuration (EC)

**Problems:** The task proposed.

**Languages:**

Verbal: point, line, tangent line, function, graph of a function, constant function, slope, order, decreasing, increasing, derivative at a point.

Symbolic:  $a, b, c, d, f'(a), f'(b), f'(c), f'(d), f'$

Graphic: The graphic of  $f$  and  $f'$  (solution)

**Definitions:**



Point, line, function, graph of a function, constant function, tangent line, slope, order, decreasing, increasing, derivative at a point.

It is important to emphasize that the slope is understood as the variation of the dependent variable per unit of the independent variable, and the derivative at a point as the slope of the tangent line.

**Procedures:**

Pr0: Sort real numbers.

Pr1: Determine a point of the graph by knowing its abscissa (Evaluate the function at  $x = a$  graphically).

Pr2: Sketch the tangent line at a point.

Pr3: Determine the value of the sign of the slope.

Pr4 Procedure for sketching a graph of  $f'$  from  $f$ :

Pr4a) Determine several points on the graph of  $f$  and sketch the tangent lines and visually compare the slope of tangent lines to determine the order relation between them.

Pr4b) Determine the intervals where  $f'$  is increasing and decreasing.

Pr4c) Determine several points on the graph of  $f$  and sketch the tangent lines and visually compare the slope of tangent lines to determine the speed of the variation of the inclination of the tangent lines.

Pr4d) Determine the intervals of upward and downward concavity of  $f'$ .

Pr4e) Determine graphically the intervals where the function  $f$  is increasing, decreasing, concave upward, concave downward and critical points and make the sketch of the graph of  $f'$  using information from the previous procedures.

**Propositions:**

- 1) When the line is parallel to the  $x$ -axis, the slope is equal to zero.
- 2) If a function is increasing at  $x = a$ ,  $f'(a) > 0$  and the slope of the tangent line is positive.
- 3) If a function is decreasing at  $x = a$ ,  $f'(a) < 0$  and the slope of the tangent line is negative.
- 4) When the line is parallel to the  $y$ -axis, slope does not exist (because the value is infinity).
- 5) The cut-off points of the graph with the abscissa axis are those in which the second ordinate is zero.
- 6) If the tangent at a point is parallel to the  $x$ -axis, then the derivative is 0 there and the graph of  $f'$  crosses the  $x$ -axis at that point.
- 7) If in an interval the graph of  $f$  is increasing/decreasing, the graph of  $f'$  is positive/negative in that interval.
- 8) If in an interval the graph  $f$  is concave upward/downward the graph of  $f'$  is increasing/decreasing on that interval.
- 9) If in an interval, the variation on the values of the slope of the tangent line to a function is constant, then  $f'$  is a line. If in an interval, the slope of the tangent line decreases and the variation on the values of the slope increases/decreases, then  $f'$  is concave downward/upward. If in an interval, the slope of the tangent line increases and the variation on the values of the slope increases/decreases, then  $f'$  is concave upward/downward.
- 10) If the tangent at a point is parallel to the  $y$ -axis, there is no slope (because it cannot be divided by zero).
- 11) If the graph of  $f$  contains a cusp, then the left and right tangents differ and  $f'$  does not exist at that point.

**Arguments:**

*Answer to the question 1)*

$f'(b)$  is greater than zero because the tangent line is increasing and its slope is positive .

$f'(a)$  is zero because the tangent line is parallel to the  $x$ -axis.

$f'(d)$  and  $f'(c)$  are negative because the tangent lines in these points ( $x = d, c$ ) are decreasing.

While  $f'(d)$  has greater slope than  $f'(c)$  in absolute value, since both are negative,  $f'(d) < f'(c)$ . At the same time,  $f'(d)$  and  $f'(c)$  are smaller than  $f'(a)$  because the latter is zero. Finally  $f'(b)$  is positive and greater than the previous ones. So,  $f'(d) < f'(c) < f'(a) < f'(b)$ .

*Answer to the question 2)*

There is a point on the graph of the function  $f$  in which the tangent line is parallel to the axis of ordinates, and in this case there is not slope.

There is a point where the graph has a pointed shape, in this case there is no tangent line and therefore there is not derivative at this point.

Answer to the question 3)

The function  $f'$  assigns to each value of the independent variable the derivative of  $f$  in this value. The derivative is the slope of the tangent line. Graphically, we can visually estimate the slope of the tangent line, which allows us to see that in the interval between  $d$  and  $a$ ,  $f'$  is increasing. In  $x = d$  the tangent line has a greater slope in absolute value than in the points of the abscissa greater than  $d$  and less than  $a$ . Therefore, as the slopes are negative, we see that these are increasing as we approach  $x = a$ . At this point the graph intersects the abscissa axis since  $f'(a) = 0$ .

In  $x = b$  the tangent line has a greater slope (in absolute value) than in the points of the abscissa lower than  $b$  and the same happens with any other value between  $b$  and the abscissa in which the graph of  $f$  is parallel to the axis of ordinates and, therefore, being the slopes positive, graph of  $f'$  grows towards infinity.

At the point where the tangent line is parallel to the axis of ordinates there is no slope, then for the values greater than the abscissa at this point the tangent line is increasing, with positive slope, but the slope has a smaller increase than in the points with lower abscissa. Therefore, since the slopes are positive, we see that these are diminishing as we approach the point where the graph has a pointed (corner) shape. At this point there is not derivative, there is a discontinuity in the graph of  $f'$ . In the points with abscissa greater than the corner point, the graph is a straight line so the tangent line coincides with it. Then, for all values of abscissa greater than that of the pointed (corner) point, the slope is always the same and the graph is constant.

### Third step: A look from the APOS (Genetic Decomposition)

In order to carry out the practices described in the previous section (in particular for sketching the graph of  $f'$ ) according to the OSA, it is necessary for the student to perform the following actions from the point of view of APOS. In the following lines, we describe mental constructions that a student might need to construct in order to learn or solve this type of problems, sketching the graph of  $f'$  when given the graph of  $f$ .

*Action 1:* Determine the points where the derivative exists. For those points where it exists, estimate graphically the value of sign of the derivative at the point  $A(a, f(a))$ .

*Action 2:* Sketch approximately the point  $A'(a, f'(a))$ .

*Action 3:* Compare and order the slopes of the tangents in two or more points of the graph of the function.

*Process 1:* Interiorization and mental repetition of above actions for finding and draw intervals of increment and decrement of  $f'(x)$ .

*Object 1:* Encapsulation the process 1 to an object conception (Relation between the graph  $f$  and increasing/decreasing of the graph  $f'$  on the corresponding interval).

*Process 2:* Interiorization and mental repetition of above actions for finding and draw intervals of upward and downward concavity of the graph  $f'(x)$ .

*Object 2:* Encapsulation the process 2 to an object conception (Relation between the graph  $f$  and upward/downward concavity of the graph  $f'$  on the corresponding interval).

*Process 3:* Coordination of the two processes above described into a new process in which the sketch of the graph of  $f'$  can be obtained from the graph of  $f$ .

*Schema:* Establishing relations between these actions, processes and objects with others (slope, line, tangent line, estimations of real numbers, function, derivative, derivative at one point, graph, angle, etc.) to construct a schema for the sketch of the graph of  $f'$  from a graph of  $f$ .

These mental constructions allow the student to make the graph of  $f'$  from the graph of  $f$  so that the student is able to sketch the graph  $f'(x)$  as a standard and canonical graph throughout the whole domain.

### Relation between EC, GD and Levels of Development of the Schema

In the APOS, the GD is a model of the predicted constructions that students should make in the process of learning a concept, it does not allow the students to perform anything, since it is a theoretical model it cannot allow anything to students. From the point of view of OSA, the EC is activated when the students perform practices. So then, from the perspective of OSA, the mental constructions of the GD allow the student to perform the practice that solves the problem and activate the EC described in section "Second step: A look from the OSA". The actions described in this GD in terms of the OSA would be part of the practice that the student makes to solve the problem. These practices are regulated by the primary objects of the EC, especially by the procedures, in some way are equivalent to the processes of the GD (process 1 of GD is similar to procedures Pr4a and Pr4b and process 2 is similar to procedures Pr4c, Pr4d and pr4e; process 3 is similar to the whole Pr4 procedure). The objects of this GD are similar to some propositions of the EC, Object 1 is similar to the proposition 8, and object 2 is similar to proposition 9. The schema is similar to all EC.

In **Table 1**, we present some relations between mental construction described in the GD and primary objects described in the EC. At the same time, the GD is described in terms of the characteristics of the levels of development of the Schema.

**Table 1.** Some relations between GD, EC and levels of development of the schema

EC (OSA)	GD (APOS)	Levels of development of the Schema (APOS)
<p><i>Procedures:</i> Pr0, Pr1, Pr2 and Pr3  <i>Propositions:</i> 1, 2, 3, 5 and 6  <i>Arguments:</i> The student cannot respond to the questions 1, 2 and 3 of the task. It is remarkable that this student cannot make the procedure 4 and for this reason he cannot sketch well the graph of <math>f'</math>.</p>	<p><i>Action 1:</i> Determine the points where the derivative exists. For those points where it exists, estimate graphically the value of sign of the derivative at the point <math>A(a, f(a))</math>.  <i>Action 2:</i> Sketch approximately the point <math>A'(a, f'(a))</math>.  <i>Action 3:</i> Compare and order the slopes of the tangents in two or more points of the graph of the function.</p>	<p><i>Intra level:</i> The student uses only the positive/negative value of <math>f'</math> and does not have any notice on increasing/decreasing <math>f'</math> on different intervals and does not identify the points where the derivative does not exist. The student can perform some mental constructions of the GD considered as actions, but there are some mistakes because some of the propositions of the EC are not considered and fails applying some procedures. The student cannot sketch well the graph of <math>f'</math> because he/she has not constructed the necessary relations between actions, processes, objects and other schemas.</p>
<p><i>Procedures Pr4a and Pr4b:</i> Determine several points on the graph of <math>f</math> and sketch the tangent lines and visually compare the slope of tangent lines to determine the order relation between them. Determine the intervals where <math>f'</math> is increasing and decreasing.  <i>Propositions:</i> 7 and 8  <i>Arguments:</i> The student can respond to the question 1 of the task. In relation to the question 2, the student can only find the corner point as a point that is not differentiable. Concerning question 3, the student can sketch correctly the graph <math>f'</math> only in some parts of the domain. The fact that he/she does not know propositions 9, 10 and 11, impedes correct drawing of the graph of <math>f'</math>.</p>	<p><i>Process 1 and Object 1:</i> Relation between the graph <math>f</math> and increasing/decreasing of the graph <math>f'</math> on the corresponding interval.  <i>Process 2 and Object 2:</i> Relation between the graph <math>f</math> and upward/downward concavity of the graph <math>f'</math> on the corresponding interval.</p>	<p><i>Inter level:</i> The student is able to understand and use positive/negative property of <math>f'</math> and increasing/decreasing property of <math>f'</math>, in order to determine intervals of increment and decrement of <math>f'(x)</math>, and draw intervals of upward and downward concavity of the graph <math>f'(x)</math>. However, some students perhaps cannot apply these two properties to the whole domain because they do not completely relate the components of the GD. If the graph of <math>f</math> has some critical points (especially discontinuous points, corner points or points with vertical tangent line) the student cannot sketch the graph of <math>f'</math> at these points correctly.</p>
<p><i>Procedures:</i> Whole Pr4  <i>Propositions:</i> 9, 10 and 11  The student can correctly perform the graph of the function <math>f'</math> from the graph of <math>f</math> because he/she can activate all the primary objects of the EC and can use them correctly in the problem solving process.</p>	<p><i>Process 3:</i> Coordination of the two processes above described into a new process in which the sketch of the graph of <math>f'</math> can be obtained from the graph of <math>f</math>.  <i>Schema:</i> Actions, Processes, Objects, and other Schemas, and connections among these constructs.</p>	<p><i>Trans level:</i> The student is able to sketch the graph <math>f'</math> based on both the sign property of <math>f'</math> (positive/negative) and the monotonic property of <math>f'</math> (increasing/decreasing) throughout the domain. The student is able to consider the critical points of <math>f</math> and sketch the graph <math>f'</math> at these points correctly.</p>

### Fourth Step: Example of Transcription with the Description of Actions and Gestures of the Student

*Farzaneh:* At  $x = a$ , derivative is zero because tangent is parallel to the  $x$ -axis and I plot  $(a, 0)$  on the  $x$ -axis. From  $-\infty$  to  $a$  graph  $f$  is decreasing then I sketch graph  $f'$  below  $x$ -axis and connect it to  $(a, 0)$ . From  $a$  to vertical tangent place, graph  $f$  is increasing therefore  $f'$  on this interval is positive and its graph is above  $x$ -axis. At vertical tangent place,  $f'$  tends to  $\infty$ . From vertical tangent place to corner point, graph  $f$  is increasing and values of slopes on this interval are decreasing (she sketches her graph on this interval). For the corner point, I plot a hollow point on the  $x$ -axis (she has difficulties in her sketching after the corner point). (Figure 2).

## RESULTS

We analyzed the mathematical activity in the students' responses and characterized their schemas into three groups (Table 2), which can be associated with intra, inter and trans levels of development of a schema, as described in Table 1. In our analysis, there were ten students who had constructed their schemas at the intra level, three students who had constructed their schemas at the inter level, and only one student who had constructed a schema at the trans level. Due to the limitations of the space on the paper, we present only one example of the analysis of

student's responses that allows to characterize their schemas in each level of the triad. To relate OSA and APOS, we also analyzed the responses of students in each level based on EC of the OSA.

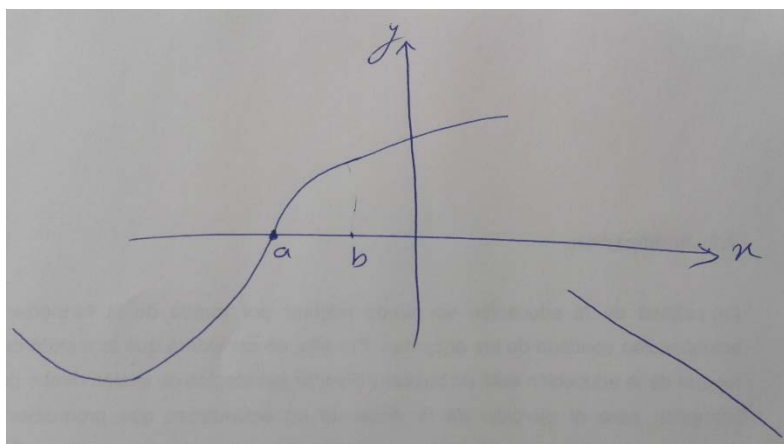
**Table 2.** Levels of development of students' schemas

Level of triad	Intra	Inter	Trans
Number of students	10	3	1

### First Group: Intra Level

Behnaz was one of the students who constructed a schema at the intra level. We present the transcription of her answer.

*Behnaz: The derivative at  $x = a$  is zero (she plots the point  $(a, 0)$  on the  $x$ -axis). Before  $a$ , graph  $f$  is decreasing therefore graph  $f'$  is below  $x$ -axis. In  $a$ , derivative is zero, from  $a$  to  $b$  the graph  $f'$  is above  $x$ -axis (she sketches her graph in interval  $[a, b]$ ). From  $b$  to the corner point, the graph of  $f$  is increasing. At the corner point, there is not derivative (but she cannot sketch it correctly). After corner point, the graph  $f$  is decreasing therefore graph  $f'$  is below  $x$ -axis (Figure 1).*



**Figure 1.** Behnaz's graph (Intra level)

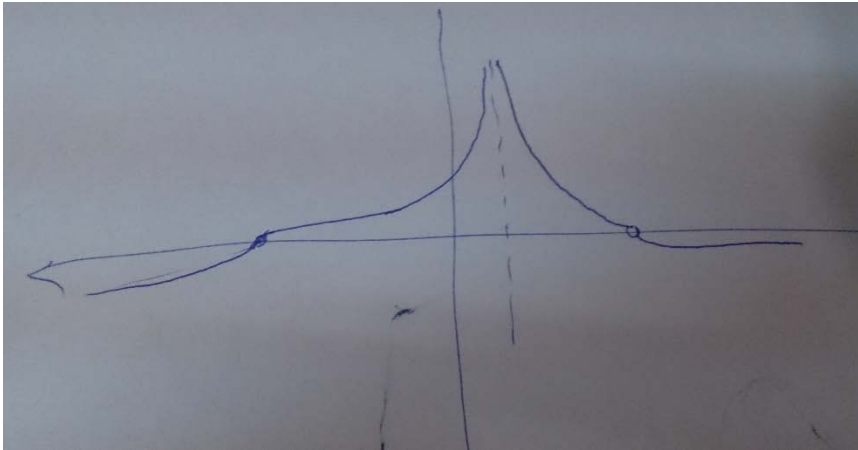
Behnaz is able to understand some properties of the graph of  $f'$ , she uses only the positive/negative value of  $f'$  and does not have any notice on increasing/decreasing  $f'$  on different intervals and does not identify the points where the derivative does not exist. Behnaz can perform some mental constructions of the GD considered as actions.

Behnaz can do only the procedures: Pr0, Pr1, Pr2 and Pr3, propositions: 1, 2, 3, 5 and 6 of EC. With respect to arguments in EC, she cannot respond to the questions 1, 2 and 3 of the task. It should be noted that this student cannot make the procedure 4 and for this reason she cannot sketch well the graph of  $f'$ .

### Second Group: Inter Level

Farzaneh was one of the students who constructed a schema at the inter level. Her graph is in the **Figure 2**.

*Farzaneh: At  $x = a$ , derivative is zero because tangent is parallel to the  $x$ -axis and I plot  $(a, 0)$  on the  $x$ -axis. From  $-\infty$  to  $a$  graph  $f$  is decreasing then I sketch graph  $f'$  below  $x$ -axis and connect it to  $(a, 0)$ . From  $a$  to vertical tangent place, graph  $f$  is increasing therefore  $f'$  on this interval is positive and its graph is above  $x$ -axis. At vertical tangent place,  $f'$  tends to  $+\infty$ . From vertical tangent place to corner point, graph  $f$  is increasing and values of slopes on this interval are decreasing (she sketches her graph on this interval). For the corner point, I plot a hollow point on the  $x$ -axis (she has difficulties in her sketching after the corner point).*



**Figure 2.** Farzaneh's answer to question 3

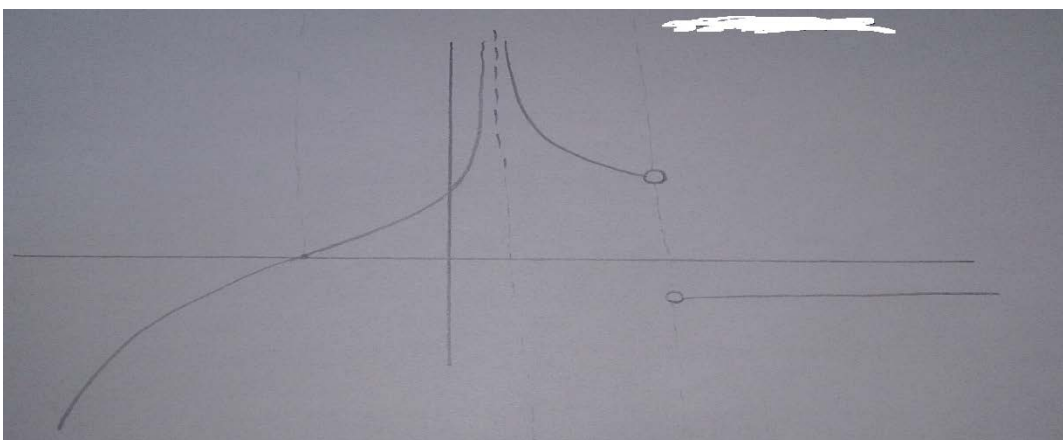
Farzaneh is able to understand and use the positive/negative property of  $f'$  and the increasing/decreasing property of  $f'$ , but she cannot apply these two properties to the whole domain. As the graph of  $f$  has some critical points (discontinuous points, corner points or points with vertical tangent line) this student cannot sketch the graph of  $f'$  at some of these points correctly. In relation to the EC in OSA, she understands and can do only procedures: Pr0, Pr1, Pr2, Pr3, Pr4a and Pr4b and also uses propositions: 1, 2, 3, 5, 6, 7 and 8 of EC (in some intervals). The fact that she does not know propositions 9, 10 and 11 impedes correct drawing of the graph of  $f'$ .

With respect to arguments in EC, this student can correctly and completely respond to the question 1 of the task. In relation to the arguments needed to solve the question 2, Farzaneh can find the corner point as a point that is not differentiable, but she cannot draw the graph of  $f'$  correctly around this point in question 3 of the task. She answers correctly for the point with vertical tangent. Concerning question 3, she can sketch correctly the graph  $f'$  only in some parts of the domain.

### Third Group: Trans Level

Sanaz was the only student who constructed a schema at the trans level (**Figure 3**).

*Sanaz: I know that at  $x = a$ , derivative is zero so graph  $f'$  crosses  $x$ -axis in  $(a, 0)$ . From  $-\infty$  to  $a$ , slopes are increasing and their values tend to zero,  $f'$  is negative (then she sketches the graph of  $f'$  on this interval). From  $a$  to vertical tangent place the slopes are increasing and in vertical tangent place, slope value tends to  $+\infty$  (then she sketches the graph of  $f'$  on this interval). Between vertical tangent place and the corner point, the graph of  $f$  is increasing therefore  $f'$  is positive but in this interval slopes' values change from  $+\infty$  to positive number, therefore  $f'$  is decreasing and has concavity upward (then she sketches the graph of  $f'$  on this interval, decreasing with an upward concavity). In corner point, there are different values for the slope of the tangent line at each side of it. Therefore, the graph of  $f'$  is*



**Figure 3.** Sanaz's graph (trans level)

*discontinuous (then she plots a hollow point). After corner point the graph of  $f$  is a line, therefore its derivative is a constant negative number because the graph of  $f$  is decreasing on this interval.*

Sanaz is able to sketch the graph  $f'$  based on both the sign property of  $f'$  (positive/negative) and the monotonic property of  $f'$  (increasing/decreasing) throughout the domain. She is able to consider the critical points of  $f$  and sketch the graph of  $f'$  at these points correctly. In relation to the EC of the OSA, this student can correctly draw the graph of the function  $f'$  from the graph of  $f$  because she can activate all the primary objects of the EC and can use them correctly in problem solving process.

## CONCLUSION

We want to emphasize that we used the APOS theory to determine which mental constructions (actions, processes, objects and schemas) are involved in the resolution of the task. We used OSA to identify primary objects (problems, languages, concepts/definitions, procedures, propositions and arguments) that are present when previous mental constructions are made. On the other hand, we related the existence or lack of mental constructions and primary objects to the difficulties identified in students' responses, which enables us to characterize students' schemas in levels intra, inter or trans.

The results show that most of the students in our study had major problems in developing mental constructions and performing the practical work needed to solve the problem, particularly those mental constructions that have to be made to calculate the derivative at the critical points and to determine the speed of the variation of the inclination of the tangent lines to  $f$ , which is why most of them (10 students) have constructed a schema at the intra level of development of the schema for sketching  $f'$  when given the graph  $f$ .

Since all students in our research (except one of them) have constructed their schemas at the intra (10 students) and inter level (3 students), here we give more details about their problems of understanding, especially at the critical points.

Considering the whole domain of the function, on intervals where  $f$  is increasing/decreasing,  $f'$  is positive/negative and on intervals where  $f$  is concave upward/downward,  $f'$  is increasing/decreasing. Some students sketched a graph for  $f'$  similar to the graph  $f$  without appreciating the relation between a function and the derivative over the intervals. They did not mention in their explanations, that if  $f$  is increasing then  $f'$  will be positive and if  $f$  is decreasing then  $f'$  will be negative. This phenomena is also reported in Nemirovsky and Rubin (1992). The second group of student had a higher level of understanding than the first group; they explained that if  $f$  is increasing, then  $f'$  would be positive and situated above the  $x$ -axis and vice versa. However, they did not notice the relation between the concavity of  $f$  and increasing/decreasing value of  $f'$ .

The graph of the function  $f$  includes three critical points, one at  $x = a$  where derivative is zero, another one at the vertical tangent where the slope does not exist, and the last one at the corner point. All our students (except one of them) had good understanding of the first critical point. At  $x = a$ , they knew the graph of  $f'$  must pass through  $(a, 0)$ . However, most of the students had difficulties at the vertical tangent and the corner point. A significant number of students had problems for sketching  $f'$  in the interval between the point with the vertical tangent and the corner point and also in the interval between corner point and  $+\infty$  (the interval where  $f$  is a descending line).

We obtain many results about students' problems on the vertical tangent. Some of the students did not know that the slope of a vertical line does not exist (for instance, when we asked them what is the slope of the line  $x = 1$ , some of them answered that the slope of this line is equal to 1) and they simply ignored the vertical tangent and counted it as a differentiable point of  $f$ . Some of the students knew that the slope of a vertical line does not exist, but they could not sketch the graph of  $f'$  at this point because their graph did not lead to  $+\infty$ . One group of them presented this point as a hole point on the graph  $f'$ . In other group, their graph went to infinity at the left side of the vertical tangent, though they encountered problems plotting  $f'$  at the right side of the vertical tangent and did not know where they had to begin plotting.

We also found interesting results concerning the corner point. For example, when we asked students to draw a tangent on a corner point, some answered that there are infinite number of tangents at the corner point, some others said there is no tangent at the corner point. Most of the students did not know that there are only two tangents at the corner point, right and left derivatives are not equal. The graph of  $f'$  of most of students in this point was continuous. Also, we found that students usually encountered two general problems in the case of corner point. The first group explained that the function had no derivative at this point, but totally ignored this statement, and they sketched one graph for the function  $f'$  that was continuous and differentiable at that point. The second group showed this point with a hole point on the graph. The graph of  $f'$  of this group had a removable discontinuity, meaning  $f'$  was not defined at this point but  $f'_+ = f'_-$ .

In the interval between the point with the vertical tangent and the corner point, function  $f$  is increasing; therefore,  $f'$  at this interval is positive, and the graph  $f'$  must be above the  $x$ -axis. Moreover, when we considered



this interval, the slope decreases at each point (the concavity is downward). To put it in other words, derivative leads from positive infinity towards a certain positive number (the left derivative at the corner point); therefore, the graph of  $f'$  is decreasing at this interval and is above the  $x$ -axis. Examining students' answers on this interval, we noticed that most of the students had problems to correlate the concavity of the function with the increase or decrease of  $f'$ .

After the corner point, the graph of  $f$  is a straight decreasing line, so the slope is constant and negative. Therefore, the graph of  $f'$  at this interval is a straight line below  $x$ -axis and parallel to it. On students' answers, we found in general three problems that they normally encountered. The first problem was that some students sketched a straight decreasing line above  $x$ -axis for this interval. The second group of students sketched the same line similar to the one of the first group but below  $x$ -axis. The last group sketched a straight line parallel to  $x$ -axis and above it for this interval, and they did not notice that derivative at this interval is negative. One of the students plotted a decreasing line with a downward concavity below the  $x$ -axis, for this interval. This particular student stated in her explanation that, since  $f$  is decreasing at this interval,  $f'$  is positioned below the  $x$ -axis. What this student had not noticed was that the slope on this interval is constant. The difficulties observed with the vertical tangent and corner points are consistent with previous studies, for example Baker et al. (2000).

The future perspectives of this study is to deepen the networking between APOS and OSA and apply it to other Calculus's objects that have been little studied so far. In particular, we are conducting research about students' understanding of implicit differentiation using both frameworks.

## REFERENCES

- Amit, M., & Vinner, S. (1990). Some misconceptions in calculus: Anecdotes or the tip of the iceberg? In G. Booker, P. Cobb, & T. N. de Mendicuti (Eds.), *Proceedings of the 14th International Conference for the Psychology of Mathematics Education*, (Vol. 1, pp. 3-10.) Cinvestav, Mexico: PME.
- Arnon, I. Cottrill, J., Dubinsky, E., Oktac, A., Roa, S., Trigueros, M., & Weller, K. (2014). *APOS Theory: A Framework for Research and Curriculum Development in Mathematics Education*. New York, Heidelberg, Dordrecht, London: Springer.
- Asiala, M., Cottrill, J., Dubinsky, E., & Schwingendorf, K. E. (1997). The development of students' graphical understanding of the derivative. *Journal of Mathematical Behavior*, 16(4), 399-430. [https://doi.org/10.1016/S0732-3123\(97\)90015-8](https://doi.org/10.1016/S0732-3123(97)90015-8)
- Badillo, E., Azcárate, C., & Font, V. (2011). Analysis of Mathematics teachers' level of understanding of the objects  $f'(a)$  and  $f'(x)$ . *Enseñanza de las ciencias*, 29(2), 191-206. <https://doi.org/10.5565/rev/ec/v29n2.546>
- Baker, B., Cooley, L., & Trigueros, M. (2000). A calculus graphing schema. *Journal for Research in Mathematics Education*, 31(5), 557-578. <https://doi.org/10.2307/749887>
- Borji, V., & Alamolhodaie, H. (2016a, August 28-31). *Freshman students' graphical understanding of the first and second derivative based on APOS theory and Schema development*. Paper presented in the 47<sup>th</sup> Annual Iranian Mathematics Conference: Kharazmi University, Tehran, Iran.
- Borji, V., & Alamolhodaie, H. (2016b, September 6-8). *Students' understanding of the derivative concept based on APOS framework*. Paper presented in the 14<sup>th</sup> Iranian Mathematics Education Conference (IMEC14), Shiraz, Iran.
- Borji, V., & Voskoglou, M. G. (2016). Applying the APOS Theory to Study the Student Understanding of the Polar Coordinates. *American Journal of Educational Research*, 4(16), 1149-1156. <https://doi.org/10.12691/education-4-16-5>
- Borji, V., & Voskoglou, M. G. (2017). Designing an ACE Approach for Teaching the Polar Coordinates. *American Journal of Educational Research*, 5(3), 303-309. <https://doi.org/10.12691/education-5-3-11>
- Breda, A., Pino-Fan, L., & Font, V. (2017). Meta didactic-mathematical knowledge of teachers: criteria for the reflection and assessment on teaching practice. *EURASIA Journal of Mathematics, Science & Technology Education*, 13(6), 1893-1918. <https://doi.org/10.12973/eurasia.2017.01207a>
- Clark, J. M., Cordero, F., Cottrill, J., Czarnocha, B., DeVries, D. J., St. John, D., Toliás, G., & Vidakovic, D. (1997). Constructing a schema: The case of the chain rule? *Journal of Mathematical Behavior*, 16(4), 345-364. [https://doi.org/10.1016/S0732-3123\(97\)90012-2](https://doi.org/10.1016/S0732-3123(97)90012-2)
- Dominguez, A., Barniol, P., & Zavala, G. (2017). Test of Understanding Graphs in Calculus: Test of Students' Interpretation of Calculus Graphs. *EURASIA Journal of Mathematics, Science and Technology Education*. 13(10), 6507-6531. <https://doi.org/10.12973/ejmste/78085>
- Drijvers, P., Godino, J. D., Font, V., & Trouche, L. (2013). One episode, two lenses: A reflective analysis of student learning with computer algebra from instrumental and onto-semiotic perspectives. *Educational Studies in Mathematics*, 82(1), 23-49. <https://doi.org/10.2307/23434838>

- Dubinsky, E., & McDonald, M. (2001). APOS: A constructivist theory of learning in undergraduate mathematics education research. In D. Holton (Ed.), *The teaching and learning of mathematics at university level: An ICMI study* (pp. 273–280). Dordrecht, The Netherlands: Kluwer.
- Ferrini-Mundy, J., & Graham, K. (1994). Research in calculus learning: Understanding limits, derivatives, and integrals. In J. Kaput & E. Dubinsky (Eds.), *Research issues in Undergraduate mathematics learning* (pp. 19-26). Washington, DC: Mathematical Association of America.
- Font, V. (2000). *Procediments per obtenir expressions simbòliques a partir de gràfiques. Aplicacions a les derivades* (Unpublished PhD thesis), University of Barcelona, Spain.
- Font, V. (2005). Una aproximación ontosemiótica a la didáctica del análisis. In A. Maz, B. Gómez, & M. Torralba (Eds.), *Investigación en Educación Matemática. Noveno Simposio de la Sociedad Española de la Investigación en Educación matemática (SEIEM)* (pp. 109-128). University of Cordoba, Spain.
- Font, V., & Contreras, A. (2008). The problem of the particular and its relation to the general in mathematics education. *Educational Studies in Mathematics*, 69(1), 33-52. <https://doi.org/10.1007/s10649-008-9123-7>
- Font, V., Badillo, E., Trigueros, M., & Rubio, N. (2012). La encapsulación de procesos en objetos analizada desde la perspectiva del enfoque onto-semiótico. In A. Estepa et al. (Eds.), *Actas del XVI Simposio de la Sociedad Española de Investigación en Educación Matemática* (pp. 239-247). Jaen, Spain: SEIEM.
- Font, V., Godino, J. D., & Gallardo, J. (2013). The emergence of objects from mathematical practices. *Educational Studies in Mathematics*, 82(1), 97–124. <https://doi.org/10.1007/s10649-012-9411-0>
- Font, V., Malaspina, U., Gimenez, J., & Wilhelmi, M. (2011). Mathematical objects through the lens of three different theoretical perspectives. In T. Rowland et al. (Eds.), *Proceedings of the VII congress of the European society for research in mathematics education* (pp. 2411-2420). Rzeszow, Poland: University of Rzeszow.
- Font, V., Montiel, M., Vidakovic, D., & Wilhelmi, M. R. (2011). Analysis of dimensional analogy by means of different theoretical perspectives. In Roberta V. Nata (Ed.), *Progress in education*, volume 19 (pp. 39-76). Hauppauge, NY: Nova publishers.
- Font, V., Trigueros, M., Badillo, E., & Rubio, N. (2012). What is a Mathematical object? Looking to objects from two theoretical perspectives: APOS and OSA. Pre-Proceedings of the 12th International Congress on Mathematical Education, Seoul, Korea: ICME.
- Font, V., Trigueros, M., Badillo, E., & Rubio, N. (2016). Mathematical objects through the lens of two different theoretical perspectives: APOS and OSA. *Educational Studies in Mathematics*, 91(1), 107-122. <https://doi.org/10.1007/s10649-015-9639-6>
- Fuentealba, C., Sánchez-Matamoros, G., Badillo, E., & Trigueros, M. (2017). Thematization of derivative schema in university students: Nuances in constructing relations between a function's successive derivatives. *International journal of mathematical education in science and technology*, 48(3), 374-392. <https://doi.org/10.1080/0020739X.2016.1248508>
- García, M., Llinares, S., & Sánchez-Matamoros, G. (2011). Characterizing thematized derivative schema by the underlying emergent structures. *International Journal of Science and Mathematics Education*, 9(5), 1023–1045. <https://doi.org/10.1007/s10763-010-9227-2>
- Lauten, A., Graham, K., & Ferrini-Mundy, J. (1994). Student understanding of basic calculus concepts: Interaction with the graphics calculator. *Journal of Mathematical Behavior*, 13(2), 225-237. [https://doi.org/10.1016/0732-3123\(94\)90026-4](https://doi.org/10.1016/0732-3123(94)90026-4)
- Leinhardt, G., Zaslavsky, O., & Stein, M.K., (1990). Functions, Graphs, and Graphing: Tasks, Learning, and Teaching. *Review of Educational Research*, 60(1), 1-64. <https://doi.org/10.3102/00346543060001001>
- Mackie, D., & Court, S. (2002). Using Computer Algebra to Encourage a Deep Learning Approach to Calculus. In *Proceedings of the 2nd International Conference on the Teaching of Mathematics*. Retrieved from <http://users.math.uoc.gr/~ictm2/>
- Nemirovsky, R., & Rubin, A. (1992). Students' tendency to assume resemblances between a function and its derivatives. *TERC Working 2-92*. Cambridge MA: TERC.
- Oehrtman M. C., Carlson, M. P., & Thompson P. W. (2008). Foundational reasoning ability that promote coherence in students' function understanding. In M. P. Carlson & C. Rasmussen (Eds). *Making the connection: research and practice in undergraduate mathematics*, (pp. 150–171). Washington, DC: Mathematical Association of America.
- Orton, A. (1983). Students' understanding of differentiation. *Educational Studies in Mathematics*, 14(3), 235-250. <https://doi.org/10.1007/BF00410540>

- Özmantar, M. F., Akkoç, H., Bingölbali, E., Demir, S., & Ergene, B. (2010). Pre-Service Mathematics Teachers' Use of Multiple Representations in Technology-Rich Environments. *EURASIA Journal of Mathematics, Science and Technology Education*, 6(1), 19-36. <https://doi.org/10.12973/ejmste/75224>
- Park, J. (2015). Is the derivative a function? If so, how do we teach it? *Educational Studies in Mathematics*, 89(2), 233-250. <https://doi.org/10.1007/s10649-015-9601-7>
- Piaget, J., & García, R. (1983). *Psychogenesis and the history of science*. New York: Columbia University Press.
- Pino-Fan, L., Font, V., Gordillo, W., Larios, V. & Breda (2017). Analysis of the Meanings of the Antiderivative Used by Students of the First Engineering Courses. *International Journal of Science and Mathematics Education*, 1-23. (online) <https://doi.org/10.1007/s10763-017-9826-2>
- Pino-Fan, L., Godino, J. D., & Font, V. (2011). Faceta epistémica del conocimiento didáctico-matemático sobre la derivada. *Educación Matemática Pesquisa*, 13(1), 141-178.
- Pino-Fan, L., Godino, J. D., & Font, V. (2018). Assessing key epistemic features of didactic-mathematical knowledge of prospective teachers: the case of the derivative. *Journal of Mathematics Teacher Education*. 21(1), 63-94. <https://doi.org/10.1007/s10857-016-9349-8>
- Robles, M. G., Telechea, E., & Font, V. (2014). Una propuesta de acercamiento alternativo al teorema fundamental del cálculo. *Educación Matemática*, 26(2), 69-109.
- Rondero, C., & Font, V. (2015). Articulación de la complejidad matemática de la media aritmética. *Enseñanza de las Ciencias*, 33(2), 29-49. <https://doi.org/10.5565/rev/ensciencias.1386>
- Sahin, Z., Erbas, A. K., & Yenmez, A. A. (2015). Relational Understanding of the Derivative Concept through Mathematical Modeling: A Case Study. *EURASIA Journal of Mathematics, Science & Technology Education*, 11(1), 177-188. <https://doi.org/10.12973/eurasia.2015.1149a>
- Sánchez-Matamoros, G. Fernández, C., & Llinares, S. (2015). Developing pre-service teachers' noticing of students' understanding of the derivative concept. *International Journal of Science and Mathematics Education*, 13(6), 1305-1329. <https://doi.org/10.1007/s10763-014-9544-y>
- Sánchez-Matamoros, G., García, M., & Llinares, S. (2008). La comprensión de la derivada como objeto de investigación en didáctica de la matemática. *Revista Latinoamericana de Matemática Educativa*, 11(2), 267-296.
- Selden, J., Selden, A., & Mason, A. (1994). Even good calculus students can't solve non-routine problems. In J. J. Kaput & E. Dubinsky (Eds.), *Research issues in undergraduate mathematics learning*, MAA Notes 33 (pp. 19-26). Washington, D.C.: Mathematical Association of America.
- Stewart, J. (2010). *Calculus, 7th Edition*. Brooks/Cole Cengage Learning, Mason.
- Tall, D. (2013). *How Humans Learn to Think Mathematically: Exploring the Three Worlds of Mathematics*. Cambridge University Press.
- Tall, D., & Vinner, S. (1981). Concept image and concept definition in mathematics with particular reference to limits and continuity. *Educational Studies in Mathematics*, 12(2), 151-169. <https://doi.org/10.1007/BF00305619>
- Tiwari, T. K. (2007). Computer Graphics as an Instructional Aid in an Introductory Differential Calculus Course. *International Electronic Journal of Mathematics Education*, 2(1), 32-48.
- Trigueros, M., & Martínez-Planell, R. (2010). Geometrical representations in the learning of two-variable functions. *Educational Studies in Mathematics*, 73(1), 3-19. <https://doi.org/10.1007/s10649-009-9201-5>
- Zandieh M. (2000). A theoretical framework for analyzing students understanding of the concept of derivative. In E. Dubinsky, A. H. Schoenfeld & J. Kaput, *Research in Collegiate Mathematics Education*. (Vol IV, pp.103-127). Providence, RI: American Mathematical Society.

<http://www.ejmste.com>



For print copies of this issue or articles please send an e-mail to:

[print@modestum.co.uk](mailto:print@modestum.co.uk)

## Effects of Learning Styles and Locus of Control on the Decision-Making Styles of Leader Managers

Salim Akyürek <sup>1\*</sup>, Salih Güney <sup>1</sup>

<sup>1</sup> Istanbul Aydin Universitesi, Istanbul, TURKEY

Received 4 March 2018 • Revised 15 March 2018 • Accepted 15 March 2018

### ABSTRACT

This research aims to explain the effect of learning styles and locus of focus on the decision-making styles of leader managers. Therefore; firstly the learning styles, locus of control, decision-making styles were identified, then the relationship between the learning style and locus of control were analysed and the effects of learning styles and locus of control on the decision-making styles were investigated. Three scales were used for the research. The Decision-Making Styles Scale (DMSS) was developed by Scott and Bruce (1995) and adapted in Turkish by Taşdelen (2002). The Locus of Control Scale was developed by Dağ (2002) through using the Internal-External Locus of Control Scale of Rotter (1966) to identify the locus of control centre. Kolb Learning Style Inventory was developed by Kolb and translated and adapted to Turkish by Aşkar and Akkoyunlu (1993). The research covers the school principals, head vice principals and vice principals of state high schools of Ministry of Education located in İzmir. The findings were analysed in SPSS 21.0 and AMOS 20.0 programs. The results of research indicate that the leader managers mainly use the rational decision-making styles. Learning styles and locus of control are partially effective on the decision-making styles and the locus of control is effective on the learning style of participants.

**Keywords:** leadership, leader manager, learning style, locus of control, decision making style

### INTRODUCTION

Human, as a social being, has the tendency to live together with other humans since its existence. The desire of humans to be together has brought the need to behave fair and protect the rights of others, organise, coordinate and manage the personal and social relations, business life in other words all living space. Humans required the existence of a group in order to fulfil their individual needs and reach their certain objectives and wanted to act together the group that they are a part of. Therefore, the individuals are now members of more than one group such as family, school, business environment, sports clubs, political parties that have an impact on their lives as well as having a significant role.

The concept of leadership has been considered as one of the important features of humans until today and has become one of the most used concepts in the daily and work life (Şahin, 2003:12). Thus, the leadership, which goes back to the history of humanity (Güney, 2015a:13) is one of the social and universal facts that is mysterious, still attracts interest, curiosity and is subject to various research and studies.

The following leading definitions aim to clarify the issue of leadership: *Leadership* is a quality, a characteristic and way of behaviour (Kotter, 2001). The essence of leadership is to impress people. *Leadership* is the relationship between a group of individuals who gathered around a common target, and an individual who determines the actions of such group of individuals (Tosun, 1992).

The manager is a concept that means the person, who manage and control (Yılmaz, 2010:21). In the simplest sense, the person, who does the profession of management, is called the manager. *Manager* is a person, who works under an organisation, is authorized to plan and control the activities of people with the final responsibility (Güney,



#### Contribution of this paper to the literature

- The results of the research indicate that the leader managers mainly tend to use the rational decision-making styles.
- The locus of control means the internal or external search of an individual about the reasons of positive and negative events in the life.
- It is identified that the learning styles of leader managers are not fully effective on the decision-making styles.

2015b). *The manager* is the individual that observes, leads and manage what people do in an organisation (Robbins et al., 2013:5).

There are various researches that discuss the differences between managers and leaders, which are mainly focused on their personalities, relations, styles to conduct and get people do business, attitudes towards their objectives and outcomes, attitudes in decision-making, perspectives and their source of power and their attitudes against change and risk.

When the leadership is defined, the main focal-point concepts are risk, change, renewal, influence, transformation, convince, trust, voluntarism, human-oriented etc., whereas for the managers, the main focus is on the concepts of authority, rules, hierarchy, enforcement, protection of status-quo. As can be seen, the differences between the manager and leader can be presented in different perspectives. The most important aspect is to understand that the manager and leader have different characteristics.

The difference between the leader and manager may resemble the difference between the phase of believing and originality. *A leader manager* is the person, who manages the organisation that he/she is responsible for, takes the organisation forward and have pioneer qualities (Ertürk, 2013:173). Thus, one of the crucial characteristics to look in a good manager is an effective leadership. In other words, *the leader manager* blends the features of a good manager and effective leader and reflects this on to the behaviours and practice.

## LEARNING STYLE

The concept of learning style, which Rita Dunn started to discuss in 1960 for the first time, expresses a reflection of personal characteristics and choices of individuals and the differences between knowledge acquisition and processing (Bengiç, 2008:19; Boydak, 2015:3; Reid, 1987:89). The researchers that were interested in the features of students concentrated on the learning styles.

The learning style is one of the biological and developmental characteristics and one learning style may not be as effective for other person. A majority of activities of an individual has uniqueness to them, the learning style is personal too. It is possible to argue that although the learning styles may be similar among people, they are not exactly the same; and since the needs, desires and choices of each individual are different, a learning style of a person may not bring any superiority. In other words, each individual chooses an original path for learning.

## LOCUS OF CONTROL

The locus of control is one of the subjects that still popular to study (Rotter, 1990:489). The concept was first used by the Phares (1957) and then become a part of psychology and social sciences as the back bone of Social Learning Theory presented by Rotter (1966) (Dağ, 1990:4).

The locus of control arisen as a result of expectation concept (Dağ, 2002:78) forms a vital aspect of personality (Rotter, 1966:1) and is among the main elements that shape the behaviours of people (Dönmez, 1983:38). The locus of control, as the main element for the theory of Rotter, reflects the beliefs of a person on his/her behaviours (Tekeli, 2010:35).

The locus of control is the effort of a person to control the beliefs, skills and abilities as well as events in the life. Additionally, it is related with the perception of who and what determines the behaviours and destiny. The locus of control reflects the belief towards the behaviours that have an impact on the events in the life. In other words, the locus of control means the internal or external search of an individual about the reasons of positive and negative events in the life. It is considered that if an individual believes that the positive or negative experiences are the results of his/her behaviours, that person has an internal locus of control, whereas if that person believes that the other elements (others, coincidence, luck, destiny, chance etc.) apart from himself/herself have an impact on the results, he/she has an external locus of control (Smith & Mihans, 2009: 63). The people who perceive the reasons of experiences internally are expressed as people with *internal locus of control*, individuals perceiving the reasons out as people with *external locus of control* (Spector et al., 2002:454).



The locus of control is a concept that determines the direction of life and aims to clarify the reason and means of individual choices. It is related with how much an individual has a control on the personal experiences.

## DECISION-MAKING STYLE

The decision and activity of decision-making have a significant place in human life. People have to make decisions in every phase of their lives and as long as they are alive in order to continue their existence, since life can be defined as the chain of decisions. Therefore, people, groups, organisations and states have to make decisions continuously in almost every issue to solve their problems and continue their sustainability.

*Decision-making* that covers mental, physical and emotional processes means to choose and make preferences among different solutions, opportunities and means that will lead to targets (Eren, 2003:185). Due to its outcomes, *decision-making* is the activity of a person by oneself or together with others of perceiving and defining the problems, collecting information and data, developing solution alternatives, comparing these alternatives and choosing among them accordingly (Koçel, 2010:136). Decision-making can be explained as a process of choice (preference) covering all physical, emotional and intellectual activities which starts with the acknowledgement of a problem, then defining the problem, identification of criteria, assessment in accordance with the criteria, choosing the best among the options on the basis of assessment, implementation of choice and control and adjustment of implementation results. It is basically making the most appropriate and best choice in accordance with the situation.

Consequently, decision-making is a fact that can be found in every phase of life. Therefore, decision-making indicates a challenging process that is essential in individual and organisational life.

## METHODOLOGY

The aim of this research is to discuss the effects of learning styles and locus of control of leader managers on their decision-making styles in a complete model. In this perspective, firstly the learning styles, locus of control and decision-making styles of leader managers were identified, then the relation between learning styles and locus of control was assessed and the effects of learning styles and locus of control on the decision-making style were analysed.

### Population and Sample

The population of this research is the managers (school principals, head vice principals and vice principals) working in the state high schools of Ministry of Education located in İzmir. There are a total number of 1143 managers in 227 state high schools in İzmir. The sample of this research is 365 managers working in the high schools. The number of managers in the sample was calculated through the stratified sampling method and the scales were applied on the quorum number of managers in the selected schools (Büyüköztürk, 2009).

### Data Gathering, Method and Tools

Three scales as Decision-Making Styles Scale (DMSS), Locus of Control Scale (LCS) and Kolb Learning Style Inventory (KLSI) were used in this study, which is a cross-sectional field study. In the data analysis, SPSS 21.0 and AMOS 20.0 programs were used.

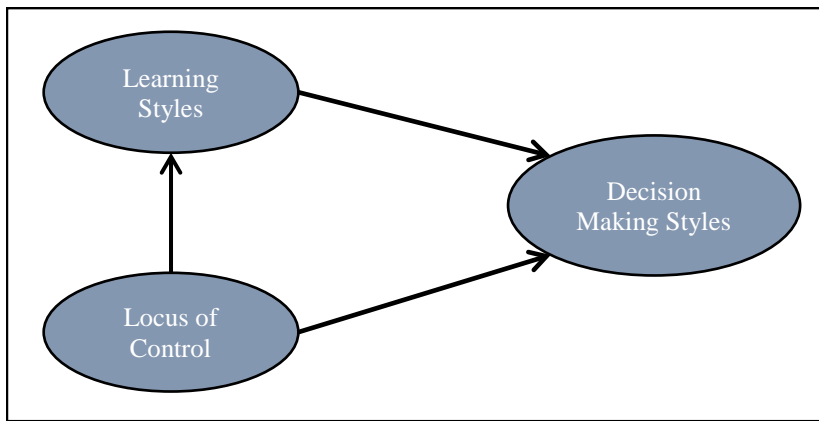
### Data Analysis, Research Model and Hypothesis

Within the scope of research, the construct validity was tested through the confirmatory factor analysis. In the confirmatory factor analysis, four different models are tested and the most fit and proper model is decided accordingly. In this perspective, Chi-Square Goodness of Fit ( $\chi^2$ ), Root Mean Square Error of Approximation-RMSEA, Root Mean Square Residual-RMR, Goodness Of Fit Index-GFI, Incremental Fit Index (CFI) were used (Anderson & Gerbing, 1984; Browne & Cudeck, 1993; Kline, 2004; Kolb & Kolb, 2009; Marsh, Balla, & McDonald, 1988; Schumacker & Lomax, 1996; Şimşek, 2007; Sümer, 2000). In order to express the inter-relations between variables and identify the direct and indirect impacts, the path analysis was conducted with Structural Equation Model (SEM). The statistical summary values regarding the fit of structural equation model were given in **Table 1**.

**Table 1.** The Statistical Summary Values of the Structural Equation Model

Modification Indices	Goodness of Fit	Acceptable Fitness
$\chi^2$ modification test	Non -Significance levels	-
( $\chi^2$ /sd)	$\leq 3$	4-5
RMR	$\leq 0.05$	0.06-0.08
RMSEA	$\leq 0.05$	0.06-0.08
GFI	$\geq 0.90$	0.89-0.85
CFI	$\geq 0.90$	0.89-0.85

Source: Şimşek, 2007

**Figure 1.** Research Model

The learning style of an individual is related with finding the most applicable solutions, ideas against a problem and using such knowledge in solution and decision-making skills (Kolb & Kolb, 2008:46). The researchers indicate a relation between the decision-making style and learning-style. In a research conducted on consumers, Sproles and Sproles (1990) used the relation between learning style and decision-making style as a basis and noted that the decision-making style is a habit that can be learnt (Nas, 2010:44). Additionally, in the classification of learning styles, there are dimensions regarding decision-making and decision-making process. The individual learns from previous experiences and shape his/her decision-making style in accordance with the learning style. In consideration with such findings in the literature, the following hypothesis are developed.

- H1:** The learning style has a significant effect on the decision-making styles.
- H2:** The locus of control has a significant effect on the decision-making styles.
- H3:** The locus of control has a significant effect on the learning styles.

A model was developed in order to identify the relations between the variables that are discussed from a theoretic perspective (Figure 1). The model has three main variables as the decision-making style as the result variable given in the model, learning styles affecting this behaviour and locus of control. The research model developed on the basis of theoretic relation is given below.

## Findings

### *Findings on the effects of learning styles on the decision-making styles*

This part of research covers the correlation analysis findings for the relation between the learning styles of leader managers and decision-making styles, and effect between the variables.

The findings of the correlation analysis conducted to identify where there is any relation between the decision-making style and learning style of leader managers are given in Table 2.

**Table 2.** Learning Styles-Decision-Making Styles / Correlational Analysis

Factor	(1)	(2)	(3)	(4)	(5)	(6)	(7)	(8)	(9)	(10)
1. Rational (RDMS)	1									
2. Intuitive (IDMS)	-.238**	1								
3. Dependent (DDMS)	.141**	.180**	1							
4. Avoidant (ADMS)	-.235**	.044	.124*	1						
5. Spontaneous (SDMS)	-.321**	.165**	-.039	.383**	1					
6. Concrete Experience (CE)	-.182**	.225**	.031	.286**	.364**	1				
7. Abstract Conceptualization (AC)	.052	-.124*	-.080	-.129*	-.203**	.365**	1			
8. Active Experience (AE)	.161**	.013	-.008	-.232**	-.073	-.429**	-.385**	1		
9. Reflective Observation (RO)	-.037	-.106**	.070	.113**	-.111**	-.226**	-.215**	-.333**	1	
Learning Styles	.093	-.201**	.019	-.257**	-.217**	-.559**	.441**	.140**	-.036	1

\* p<.05\*\*, p<.001\*

**Table 3.** Learning Styles – Decision Making Styles / Structural Equation Model Analysis

Model	$\chi^2$	$\Delta\chi^2/sd$	RMSEA	CFI	GFI	RMR
Structural Model	753.649	3.153	0.077	0.844	0.848	0.119
Modified Structural Model	499.452	2.181	0.057	0.918	0.897	0.066

\* p<0.05

The relations between the sub-dimensions of decision-making styles were analysed. In this perspective, there are positive, low significant relation ( $r = .141, p < .001$ ) between the rational decision-making style and dependent decision-making style and negative, low level and significant relation with other decision-making style ( $r = -.238, r = -.235, r = -.321; p < .001$ ). No relation was identified between the intuitive decision-making style and avoidant decision-making style ( $r = .044, p < .05$ ). There are positive low level and significant relations ( $r = .180, r = .165, p < .001$ ) between the intuitive decision-making and dependent and spontaneous decision-making style. While there is a positive, low level significant relation ( $r = .124, p < .05$ ) between the dependant decision-making style and avoidant decision-making style, there is no relation with the spontaneous decision-making style ( $r = -.39, p > .05$ ).

In consideration with the learning style and decision-making styles; there is no significant relation between the rational decision-making and abstract conceptualisation and reflective observation dimensions ( $r = .052, r = -.037, p > .05$ ), whereas the relation with the concrete experience is negative, low level and significant ( $r = .182, p < .05$ ) and with active experience is positive, low level and significant ( $r = .161, p < .05$ ). There is no relation between the intuitive decision-making style and active experience ( $r = .013, p > .05$ ), there are positive, low level and significant ( $r = .225, p < .001$ ) relations between concrete experience and intuitive decision-making ( $r = .225, p < .001$ ), and negative, low level and significant relations ( $r = -.124, r = -.106, p < .005$ ) with the abstract conceptualisation and reflective observation ( $r = -.124, r = -.106, p < .005$ ). In accordance with the analysis concerning the relations between the avoidant decision-making style and sub-dimensions of learning styles, the relation between the avoidant decision-making style and concrete experience and reflective observation is positive, low level and significant ( $r = .286, r = .113, p < .001$ ), and negative, low level and significant relations with abstract conceptualisation and active experience ( $r = -.129, p < .001, r = -.232, p < .05$ ) in consideration with the relations between the spontaneous decision-making style and sub-dimensions of learning styles, there is no significant relation between the active experience and spontaneous decision-making ( $r = -.073, p > .05$ ), positive, low level and significant with concrete experience ( $r = .364, p < .05$ ), negative, low level and significant with abstract conceptualisation and reflective observation ( $r = -.203, r = -.111, p < .05$ ). There is no significant relation between dependant decision-making and learning styles ( $r = .031, r = -.080, r = -.008, r = .070, p > .05$ ). On the other hand, there is no relation between the learning style and rational and dependent decision making style as one of the decision-making style ( $r = .93, p > .05$ ), there are significant negative relations ( $r = -.201, r = -.257, r = -.559, p < .05$ ) between intuitive, avoidant and spontaneous decision-making styles.

### Hypothesis test findings of learning style – decision-making style

In order to identify the effect of learning styles of leader managers on the decision-making styles and test the hypothesis “H1: The learning style has a significant effect on the decision-making styles”, a structural model was developed and path analysis was conducted.

The fit indices of structural model are given in Table 3. Pursuant to the fit indices, the other values other than the RMR are within the acceptable level. Therefore, the availability of higher fit value was looked through and the fit values obtained after the improvements in the model were identified as to be in the acceptable levels.

The modified structural model developed to test the hypothesis is given in the Figure 2. The model is learning style oriented and the relations between the measurement items constituting the sub-dimensions of decision-making as well as the relations between the dimensions are also given in the figure.

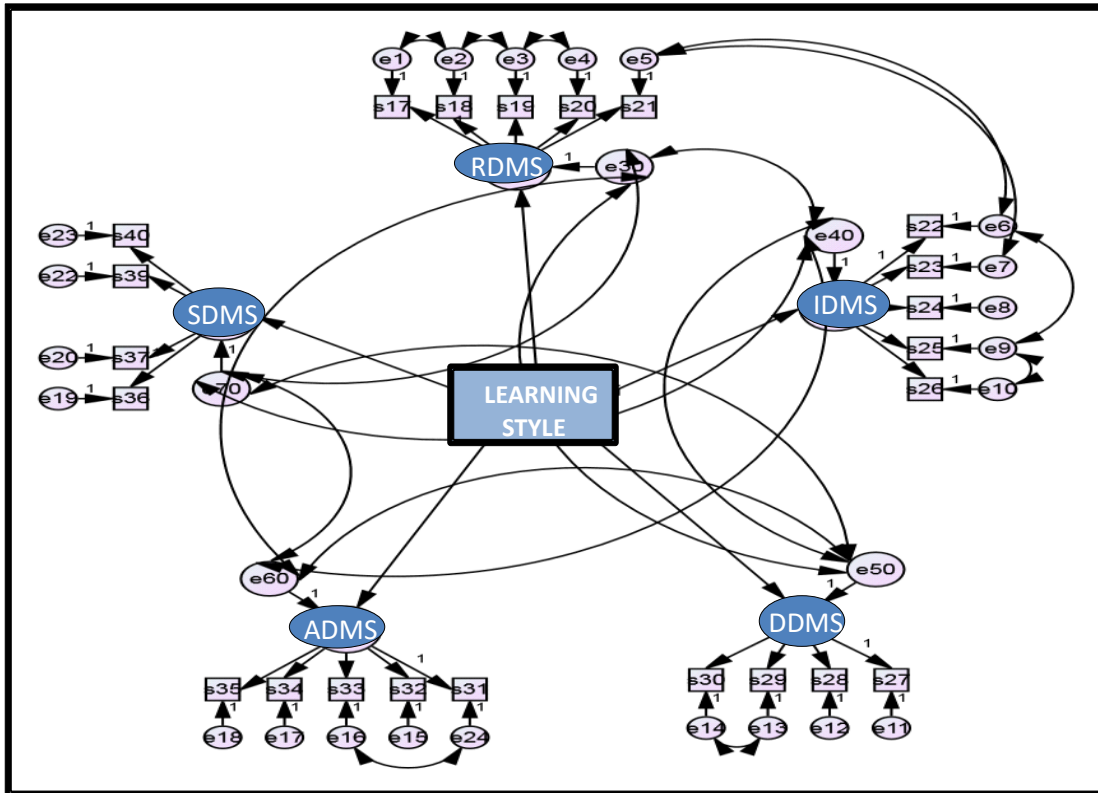


Figure 2. Learning Styles – Decision Making Styles / Structural Equation Model

Table 4. Learning Styles-Decision-Making Styles Path Analysis Results

Learning Styles	Decision Making Styles	Regression Coefficients	S.E.	p
Learning Styles	→ RDMS	,033	,028	,232
Learning Styles	→ IDMS	-,117	,040	,003
Learning Styles	→ DDMS	-,007	,043	,874
Learning Styles	→ ADMS	-,094	,025	,000
Learning Styles	→ SDMS	-,178	,039	,000

\* p<.05

The structural model developed to identify the effect of learning style on the decision-making style was used and a path analysis was conducted through AMOS package program.

In accordance with the path analysis findings given in the Table 4, the learning style has not any significant effect on the rational and dependant decision-making styles ( $\beta=.033$ ,  $\beta=-.007$   $p>.05$ ) has a negative, low level and significant effect ( $\beta=-.117$ ,  $\beta=-.094$ ,  $\beta=-.178$ ,  $p<.05$ ) on the intuitive, avoidant and spontaneous decision-making styles. Thus, H1 is partially is supported.

### Findings on the effects of locus of control on the decision-making styles

In this part of the research, the correlation analysis findings regarding the relation between the locus of control and decision-making styles of leader managers, and the path analysis findings concerning the variables.

Table 5 indicates the correlation analysis findings performed to identify whether there is any relation between the decision-making styles and locus of control of leader managers.

**Table 5.** Locus of Control-Decision Making Styles / Correlational Analysis

Factor	(1)	(2)	(3)	(4)	(5)	(6)	(7)
1. RDMS	1						
2. IDMS	-.238**	1					
3. DDMS	.141**	.180**	1				
4. ADMS	-.235**	.044	.124*	1			
5. SDMS	-.321**	.165**	-.039	.383**	1		
6. ILC	.491**	.122*	.110*	-.239**	.097	1	
7. ELC	-.084	.329**	.061	.231**	.250	-.055	1

\* p<.05\*\*, p<.001\*

**Table 6.** Locus of Control-Decision Making Styles / Structural Equation Model

Model	$\Delta\chi^2$	$\Delta\chi^2/sd$	RMSEA	CFI	GFI	RMR
Structural Model	1551.624	2.272	0.059	0.809	0.818	0.084
Modified Structural Model	1252.332	1.909	0.050	0.869	0.851	0.074

\* p<0.05

In consideration with the relations between the sub-dimensions of locus of control and sub-dimensions of decision-making styles, there are positive, intermediate and significant relation ( $r=.491$ ,  $p<.05$ ) between the rational decision-making style and internal locus of control, negative, low and significant relation ( $r=-.239$ ,  $p<.05$ ) with the avoidant decision-making styles, and positive, low level and significant relation with the intuitive and dependant decision-making styles ( $r=.122$ ,  $r=.110$ ,  $p<.001$ ). There is not any significant relation ( $r=.097$ ,  $p>.05$ ) between the spontaneous decision-making style and internal locus of control.

Pursuant to the relations between the external locus of control and sub-dimensions of decision-making styles; there is not any relation between the external locus of control and rational, dependent and spontaneous decision-making styles ( $r=-.084$ ,  $r=.061$ ,  $r=.250$ ,  $p>.05$ ); whereas there are positive, low level and significant relations ( $r=.329$ ,  $r=.231$ ,  $p<.05$ ) between the external locus of control and intuitive and avoidant decision-making styles.

### Locus of control- decision-making style hypothesis test findings

In order to identify the effect of learning styles of leader managers on the decision-making styles and test the hypothesis “H2: The locus of control has a significant effect on the decision-making styles”, a structural model was developed and path analysis was conducted.

The fit indices of structural model are given in **Table 6**. Pursuant to the fit indices, the other values other than the RMSEA are not within the acceptable level. Therefore, the availability of higher fit value was looked through and the fit values obtained after the improvements in the model were identified as to be in the acceptable levels.

The modified structural model developed to test the hypothesis is given in the **Figure 3**. The model is internal and external locus of control oriented and the relations between the measurement items constituting the sub-dimensions of decision-making as well as the relations between the dimensions are also given in the figure.

The structural model developed to identify the effect of learning style on the decision-making style was used and a path analysis was conducted through AMOS package program. In accordance with the path analysis findings given in the **Table 7**, the internal locus of control has not any effect on the dependent and spontaneous decision-making styles ( $\beta=.456$ ,  $\beta=-.751$ ,  $p<.05$ ) and have positive, high level significant effect ( $\beta=2.274$ ,  $\beta=1.193$ ,  $p<0.05$ ) on the rational and intuitive decision-making styles and have negative, high level and significant effect ( $\beta=-.837$ ,  $p<0.05$ ) on the avoidant decision-making style. The external locus of control has no significant effect ( $\beta=-.083$ ,  $\beta=.009$ ,  $p>0.05$ ) on the rational and dependent decision-making style, have positive, intermediate and significant effect ( $\beta=.563$ ,  $\beta=.454$ ,  $p<0.05$ ) on the intuitive and spontaneous decision-making style and have positive, low level and significant effect ( $\beta=.190$ ,  $p<0.05$ ) on the avoidant decision-making style. Thus, H2 can be considered as partially supported.

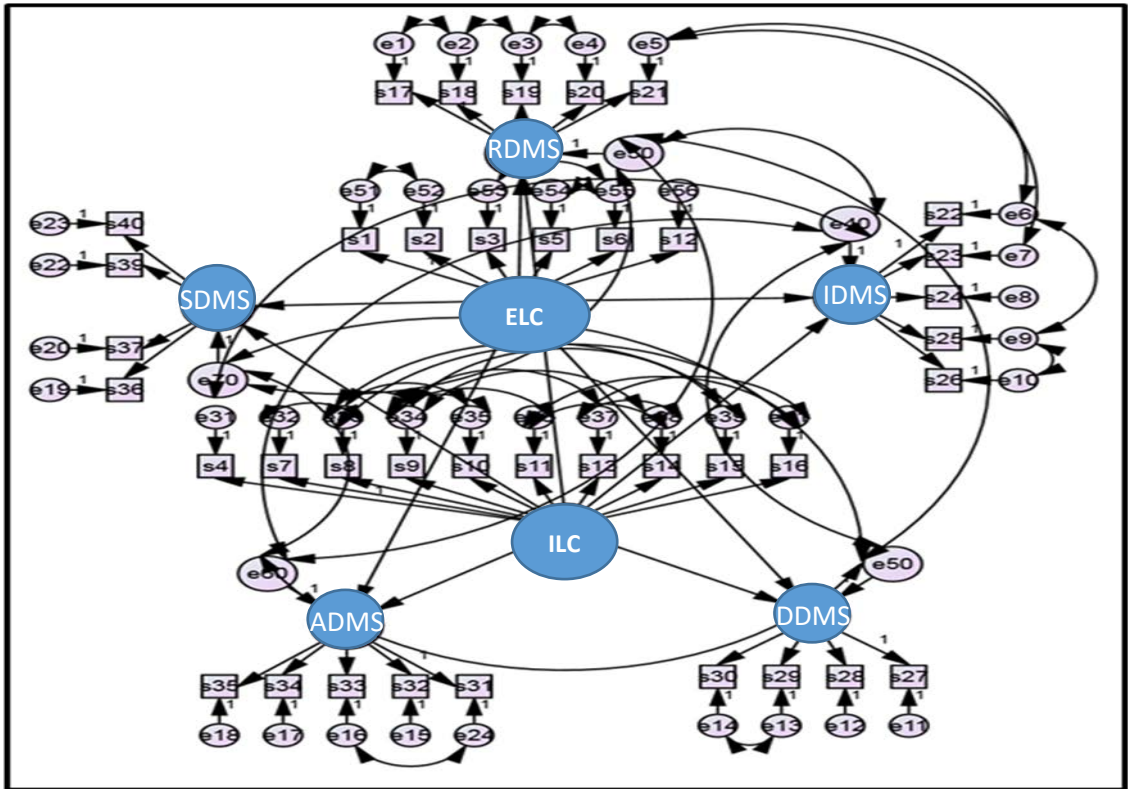


Figure 3. Locus of Control – Decision Making Styles /Structural Equation Model

Table 7. Locus of Control-Decision Making Styles – Path Analysis Results

Locus of Control	Decision Making Styles	Regression Coefficients	S.E.	p
ILC	→ RDMS	2,274	,95	,17
	→ IDMS	1,193	,558	,032
	→ DDMS	,456	,368	,215
	→ ADMS	-,837	,389	,032
	→ SDMS	-,751	,412	,068
ELC	→ RDMS	-,083	,062	,177
	→ IDMS	,563	,132	,000
	→ DDMS	,009	,113	,937
	→ ADMS	,190	,065	,004
	→ SDMS	,454	,122	,000

\* p<0.05

### Findings on the effects of locus of control on the learning styles

This part of research covers the correlation analysis findings for the relation between the locus of control and learning styles of leader managers, and effect between the variables.

The findings of correlation analysis performed to identify whether there is any relation between the locus of control and learning styles of leader managers are given in Table 8. No relation was found between the dimensions of locus of control. In general, pursuant to the analysis for the relations between the locus of control and learning style, there are positive, low level and significant relation ( $r=.114$ ,  $p<.05$ ) between the learning style and internal locus of control; negative, low and significant relation ( $r=-.271$ ,  $p<.05$ ) with the external locus of control.



**Table 8.** Locus of Control – Learning Styles / Correlational Analysis

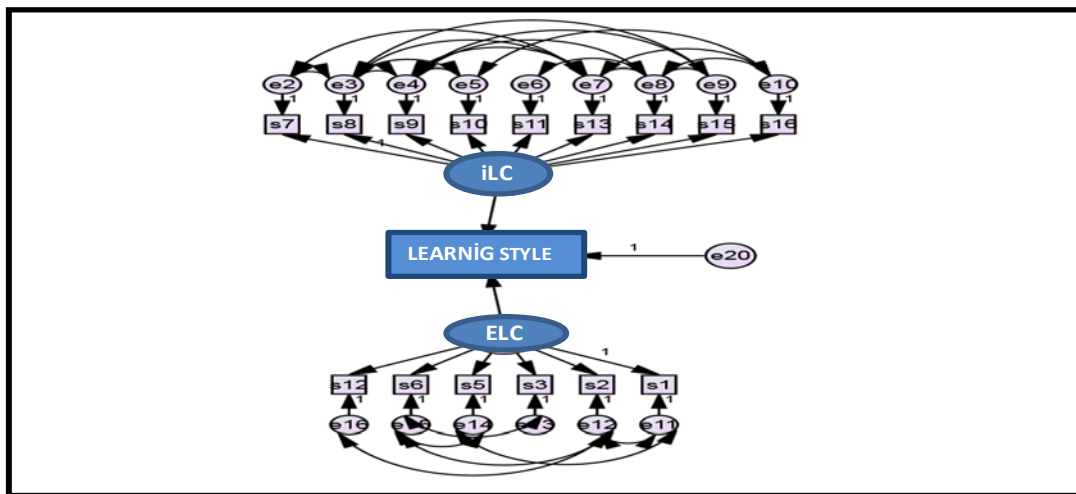
Factor	(1)	(2)	(3)	(4)	(5)	(6)	(7)
1. ILC	1						
2. ELC	-.055	1					
3. CE	-.140**	.269*	1				
4. AC	-.010	-.113**	.365**	1			
5. AE	.210**	-.148**	-.429**	-.385**	1		
6. RO	-.081	-.016	-.226**	-.215**	-.333**	1	
Learning Styles	.114**	-.271**	-.559**	.441**	.140**	-.036	1

\* p<.05\*\*, p<.001\*

**Table 9.** Locus of Control-Learning Styles / Structural Equation Model

Model	$\Delta\chi^2$	$\Delta\chi^2/sd$	RMSEA	CFI	GFI	RMR
Structural Model	195.841	2.360	0.061	0.877	0.939	0.077
Modified Structural Model	180.141	2.224	0.058	0.892	0.944	0.072

\* p<0.05



**Figure 4.** Locus of Control-Learning Styles / Structural Equation Model

In consideration with the relations between the internal locus of control and sub-dimensions of learning styles; there is a negative, low and significant relation ( $r=-.140$ ,  $p<.05$ ) between concrete experience and internal locus of control, a positive, low and significant relation ( $r=.210$ ,  $p<.05$ ) with the active experience; while there is not any significant relation with the reflective observation and abstract conceptualism dimensions ( $r=-.081$ ,  $r=-.010$ ,  $p>.05$ ).

Pursuant to the relations between the external locus of control and sub-dimensions of learning styles; there is a positive, low and significant relation ( $r=.269$ ,  $p<.001$ ) between concrete experience and external locus of control, a negative, low and significant relation ( $r=-.113$ ,  $p<.05$ ) with the abstract conceptualism, a negative, low and significant ( $r=-.148$ ,  $p<.05$ ) relation with the active experience; while there is not any significant relation between the reflective observation and external locus of control ( $r=-.016$ ,  $p>.05$ ).

### Locus of Control – Learning Style Hypothesis Test Findings

In order to identify the effect of locus of control on the learning styles of leader managers and test the hypothesis “H3: The locus of control has a significant effect on the learning styles”, a structural model was developed and path analysis was conducted.

The fit indices of structural model are given in **Table 9**. Pursuant to the fit indices, all values are within the acceptable level. However, the availability of higher fit value was looked through and the fit values obtained after the improvements in the model were identified as to be in the acceptable levels.

The modified structural model developed to test the hypothesis is given in the **Figure 4**. The model is learning style oriented and the relations between the measurement items constituting the internal and external locus of control.

The structural model developed to identify the effect of locus of control on the learning style was used and a path analysis was conducted through AMOS package program (**Table 10**).

**Table 10.** Locus of Control-Learning Styles Path Analysis Results

Variables			Regression Coefficients	S.E.	p
ILC	→	Learning Styles	.392	.027	.006
ELC	→	Learning Styles	-.543	.042	.000

\* p&lt;0.05

In accordance with the path analysis findings given in the **Table 10**, the internal locus of control has a positive effect ( $\beta=.392$ ,  $p<0.05$ ) on the learning style and the external locus of control has a negative effect ( $\beta=-.543$ ,  $p<0.05$ ). Therefore, H3 is supported.

## DISCUSSION

Through the assessment of answers given to the scales, the leader managers mainly have the rational decision-making style ( $n=200$ , 54.79%) in terms of their decision-making styles, have internal locus of control in terms of locus of control aspect ( $n=314.86\%$ ), have generally active experience from the learning style aspect (average=35.12, s.d=6.17) and have abstract conceptualisation (average=31.08, s.d.=5.64) learning styles. The leader managers primarily process the information that they obtained through their abstract conceptualisation and active living skills and then act. The others can perform conceptual modelling as a result of combining abstract conceptualisation and reflective observation skills.

In terms of the effect of locus of control on the decision-making styles, the internal locus of control has not any effect on the dependent and spontaneous decision-making styles, have a positive effect on the rational and intuitive decision-making styles and a negative effect on the avoidant decision-making style; whereas the external locus of control does not have a significant effect on the rational and dependent decision-making styles and have positive effect on the intuitive, avoidant and spontaneous decision-making styles. Therefore, it can be concluded that H2 is partially supported. This finding is also compatible with Scott and Bruce (1995), Kaplan, Reneau, and Whitecotton (2001) and Yaşar (2011).

From the perspective of locus of control and learning styles, there is a negative significant relation between concrete experience and internal locus of control; positive significant relation with the active experience yet no significant relations between the internal locus of control and reflective observation and abstract conceptualisation. In general, there is no significant positive relation between the internal control and learning style. Pursuant to the relations between the external locus of control and learning styles, with abstract conceptualisation as negatively significant and negatively significant with the active experience; however there is not any significant relation between the reflective observation and external locus of control.

As a result of the path analysis conducted towards the effect of locus of control to the learning styles, the internal locus of control was found as having a positive effect on the learning styles, whereas the external locus of control as having a negative effect on the learning styles, which indicates that H3 is supported. This finding is consistent with the research results of Deryakulu (2002), Kormanik and Rocco (2009), De Hoogh and Den Hartog (2009) and Saracaloğlu and Yılmaz (2011). The positive characteristics of leader managers with the internal locus of control as being more open to the development (Yukl & Mahsud,2010), having higher internal motives and showing easier guidance show that they do not have difficulties in implementing whatever they learn through experience. On the other hand, the leader managers with external locus of control- that the leaders were identified as being internal locus of control- can be considered as not being open to learning and development.

## CONCLUSION

As a result, the learning styles and locus of control levels can be considered as having a partial effect on the decision-making styles. The obtained findings were found as compatible with the previous research. However, unlike the others, this study discussed the effect of learning styles on the decision-making style in an integrated model. In the consequence of this study, which contributed to the literature from this aspect, it is identified that the learning styles of leader managers are not fully effective on the decision-making styles. But this finding is limited with the sample of this research therefore this should not be considered for generalisation. Additionally, since the study is cross-sectional, the findings are limited with the time period of study. Similarly, due to the use of questionnaires as data collection method, it is possible to mention the social desirability. Due to these limitations, the researchers, who will study in this domain, should repeat the same model on similar or different samples. Moreover, the effect of other personal characteristics should be studied as the determinants of decision-making styles.

The positive effect on the rational decision-making style can be explained in a such way that the leader managers with internal locus of control are more brave when it comes to taking the responsibility, and they have desire to work much freely. They believe in their qualifications and they are more into research with knowledge acquisition.

## REFERENCES

- Anderson, J. C., & Gerbing, D. W. (1984). The effect of sampling error on convergence, improper solutions, and goodness-of-fit indices for maximum likelihood confirmatory factor analysis. *Psychometrika*, 49(2), 155-173.
- Aşkar, P., & Akkoyunlu, B. (1993). Kolb Öğrenme Stili Envanteri, *Eğitim Ve Bilim*, 17(87), 37-47.
- Bengiç, G. (2008). *İlköğretim 6. ve 7. Sınıf Öğrencilerinin Öğrenme Stilleri ile Sosyal Bilgiler Dersinde Başarıları Arasındaki İlişki* (Unpublished Master Thesis), Pamukkale University Social Science Institute, Denizli.
- Boydak, A. H. (2015). *Öğrenme Stilleri*, Beyaz Publication, 21. Press, İstanbul.
- Browne, M. W., & Cudeck, R. (1993). *Alternative Ways of Assessing Model Fit*. Sage Focus Editions, 154, 136-136.
- Büyüköztürk, Ş. (2009). *Sosyal Bilimler İçin Veri Analizi El Kitabı: İstatistik, Araştırma Deseni, SPSS Uygulamaları ve Yorumları*. Ankara: Pegem Publication, 9. Press.
- Dağ, İ. (1990). *Kontrol Odağı, Stresle Başa Çıkma Stratejileri ve Psikolojik Belirti Gösterme İlişkileri* (Unpublished Phd Thesis), Hacettepe Üniversitesi Sosyal Bilimler Enstitüsü, Ankara.
- Dağ, İ. (2002). Kontrol Odağı Ölçeği (KOÖ): ölçek Geliştirme, Güvenirlik ve Geçerlik Çalışması, *Türk Psikoloji Dergisi*, 17(49), 77-90.
- De Hoogh, A. H., & Den Hartog, D. N. (2009). Neuroticism and locus of control as moderators of the relationships of charismatic and autocratic leadership with burnout. *Journal of Applied Psychology*, 94(4), 1058.
- Deryakulu, D. (2002). Denetim odağı ve epistemolojik inançların öğretim materyalini kavramayı denetleme türü ve düzeyi ile ilişkisi. *Hacettepe Üniversitesi Eğitim Fakültesi Dergisi*, 22(22).
- Dönmez, A. (1983). Denetim Odağı (Locus of Control) ve Çevre Büyüklüğü, *Ankara University Educational Science Journal*, 16(1), 37-47.
- Eren, E. (2003). *Yönetim ve Organizasyon: Çağdaş ve Küresel Yaklaşımlar* (6. Ed). İstanbul: Beta Yayınları.
- Ertürk, M. (2013). *İşletmelerde Yönetim ve Organizasyon* (7. Ed). İstanbul: Beta Press Yayın Dağıtım.
- Güney, S. (2015a). *Davranış Bilimleri* (9. Ed.). Ankara: Nobel Yayıncılık.
- Güney, S. (2015b). *Sosyal Psikoloji*. Ankara: Nobel Yayıncılık.
- Kaplan, S. E., Reneau, J. H., & Whitecotton, S. (2001). The effects of predictive ability information, locus of control, and decision maker involvement on decision aid reliance. *Journal of Behavioral Decision Making*, 14(1), 35-50.
- Kline, R. B. (2004). *Beyond Significance Testing: Reforming Data Analysis Methods in Behavioral Research*. Washington, DC: American Psychological Association.
- Koçel, T. (2010). *İşletme Yöneticiliği* (12. Ed.). İstanbul: Genişletilmiş Beta Yayınları.
- Kolb, A. Y., & Kolb, D. A. (2009). Experiential learning theory: A dynamic, holistic approach to management learning, education and development. *The SAGE handbook of management learning, education and development*, 42-68.
- Kormanik, M. B., & Rocco, T. S. (2009). Internal versus external control of reinforcement: A review of the locus of control construct. *Human Resource Development Review*, 8(4), 463-483. <https://doi.org/10.1177/1534484309342080>
- Kotter, J. P. (2001). What leaders really do. *Harvard business review*, 79(11).
- Marsh, H. W., Balla, J. R., & McDonald, R. P. (1988). Goodness-of-fit indexes in confirmatory factor analysis: The effect of sample size. *Psychological bulletin*, 103(3), 391.
- Nas, S. (2010). Karar Verme Stillere Bilimsel Yaklaşımlar. *Dokuz Eylül Üniversitesi Denizcilik Fakültesi Dergisi*, 2(2), 43-65.
- Phares, E. J. (1957). Expectancy Changes In Skill And Chance Situations. *The Journal Of Abnormal And Social Psychology*, 54(3), 339-342. <https://doi.org/10.1037/h0045684>
- Reid, J. M. (1987). The learning style preferences of ESL students. *TESOL quarterly*, 21(1), 87-111. <https://doi.org/10.2307/3586356>
- Robbins, S. P., Decenzo, D. A., & Coulter, M. (2013). *Yönetimin esasları* (A. Ögüt, Trans.). Ankara: Nobel.
- Rotter, J. B. (1966). Generalized expectancies for internal versus external control of reinforcement. *Psychological monographs: General and applied*, 80(1), 1.

- Rotter, J. B. (1990). Internal versus external control of reinforcement: A case history of a variable. *American psychologist*, 45(4), 489.
- Şahin, S. (2003). *Okul müdürlerinin liderlik stilleri ile okul kültürü arasındaki ilişkiler* (Doctoral dissertation). DEÜ Eğitim Bilimleri Enstitüsü.
- Saracaloğlu, A. S., & Yılmaz, S. (2011). Öğretmen adaylarının eleştirel düşünme tutumları ile denetim odaklarının incelenmesi. *İlköğretim Online*, 10(2).
- Schumacker, R. E., & Lomax, R. G. (2004). *A beginner's guide to structural equation modeling*. London: Routledge.
- Scott, S. G., & Bruce, R. A. (1995). Decision making style: The development of a new measure. *Educational and Psychological Measurement*, 55(5), 818-831.
- Şimşek, Ö. F. (2007). Yapısal eşitlik modellemesine giriş: Temel ilkeler ve LISREL uygulamaları. *Ankara: Ekinoks*, 315-337.
- Smith, C. A., & Mihans, R. J. (2009). Raising issues of student locus of control: Beginning a longitudinal study. *Research in Education*, 81(1), 63-65.
- Spector, P. E., Cooper, C. L., Sanchez, J. I., O'Driscoll, M., Sparks, K., Bernin, P., ... Shanfa, Y. (2002). Locus Of Control and Well-Being At Work: How Generalizable Are Western Findings? *Academy of Management Journal*, 45, 453-466.
- Sproles, E. K., & Sproles, G. B. (1990). Consumer decision-making styles as a function of individual learning styles. *Journal of Consumer Affairs*, 24(1), 134-147.
- Sümer, N. (2000). Yapısal eşitlik modelleri: Temel kavramlar ve örnek uygulamalar. *Türk psikoloji yazıları*, 3(6), 49-74.
- Taşdelen, A. (2002). *Öğretmen Adaylarının Farklı Psikososyal Değişkenlere Göre Karar Verme Stilleri* (Unpublished Doctoral Thesis), Dokuz Eylül Üniversitesi Eğitim Bilimleri Enstitüsü, İzmir.
- Tekeli, Ş. G. (2010). *Lise son sınıf öğrencileri ile üniversite öğrencileri arasında bir karşılaştırma: akademik benlik yeterliği, denetim odağı, stresle başa çıkma ve problem çözme becerisi* (Unpublished Doctoral Thesis). University of Ankara, Ankara, Turkey.
- Tosun, K. (1992). *İşletme Yönetimi*. Ankara: Savaş Yayınları.
- Yaşar, O. (2011). *Karar verme stili öncülleri: Savunma sanayinde bir araştırma* (Unpublished Doctoral Thesis). Kara Harp Okulu, Sosyal Bilimler Enstitüsü, Ankara.
- Yılmaz, H. (2010). *Stratejik Liderlik* (2. Ed.), Kum Saati Yayın Dağıtım, İstanbul.
- Yukl, G., & Mahsud, R. (2010). Why flexible and adaptive leadership is essential. *Consulting Psychology Journal: Practice and Research*, 62(2), 81. <https://doi.org/10.1037/a0019835>

<http://www.ejmste.com>

# Examining the Differences between the Job Satisfaction of STEM and Non-STEM Novice Teachers with Leaving Intentions

Ke Wang <sup>1\*</sup>, Zhuo Chen <sup>1</sup>, Wen Luo <sup>1</sup>, Yeping Li <sup>1</sup>, Hersh Waxman <sup>1</sup>

<sup>1</sup> Texas A&M University-College Station, Texas, USA

Received 26 October 2017 • Revised 5 January 2018 • Accepted 18 February 2018

## ABSTRACT

This paper examines the differences between the job satisfaction of STEM and non-STEM novice teachers with leaving intentions (hereafter STEM NTLI) by analyzing School and Staffing Survey 2011–12 data. The results of multiple regression analyses and various Z-tests show that support from the school and collaboration with colleagues are strong predictors for STEM and non-STEM NTLI. STEM NTLI focus more on professional development, autonomy in teaching, and the behavior of their students, whereas non-STEM NTLI focus more on participation in school policies. The implications for teachers and teacher educators are also discussed.

**Keywords:** job satisfaction, leaving intentions, non-STEM teachers, STEM teachers

## INTRODUCTION

In the past decade, the need for and significance of employing highly qualified teachers in the United States has been addressed in the educational literature (e.g., Berry, Hoke, & Hirsch, 2004; Darling-Hammond & Sykes, 2003; Mollenkopf, 2009). Nevertheless, many schools continue to encounter an insufficiency of teachers, including qualified teachers. According to Liu and Meyer (2005), the turnover rate for American teachers was relatively higher than that of other professions. Statistics from Goldring, Taie, and Riddles (2014) indicated that, although the rate of teacher leaving decreased slightly from 8.0% to 7.7% between 2008 and 2012, the rate actually increased from 5.6% to 7.7% between 1988 and 2012. A total of 259,300 teachers left their teaching positions in the 2012–2013 academic year. Novice teachers in particular have shown a higher tendency of leaving. Ingersoll (2003) noted that approximately 40% to 50% of novice teachers left their positions within the first five years of their careers. Consequently, and also because of the increasing student population and oncoming teacher retirement wave, the national shortage of qualified teachers is now one of the most urgent issues for schools and educational organizations (e.g., Edgar & Pair, 2005; Ingersoll, 2003; Tickle, Chang, & Kim, 2011). The solution will depend on finding ways to reduce the leaving rate, especially for novice teachers, and achieving a sustainable balance of teacher supplement and attrition.

Though many studies have examined various factors influencing teachers' leaving intentions, limited research has addressed the issue with respect to science, technology, engineering, and mathematics (STEM) teachers. Likewise, the shortage of future certified STEM teachers is a serious problem in the United States (Hutchison, 2012). STEM education has received increased attention over the past decade (e.g., Jones, Dana, LaFramenta, Adams, & Arnold, 2016; Stevenson, 2014), largely because of increased national-international developments in science, technology, engineering, and mathematics. Recognizing the need for the United States to stay competitive, a number of studies are being conducted to improve STEM education such as the National Science Foundation's Special Programs for Undergraduate Students. A report by the Committee on STEM Education National Science and Technology Council emphasizes investment in five areas: (a) increasing STEM instruction in PreK-12, (b) encouraging more people to pursue STEM, (c) providing more opportunities for undergraduate students to experience STEM, (d) serving groups underrepresented in the STEM field, and (e) designing appropriate courses for STEM graduate education (National Science and Technology Council, 2013).



### Contribution of this paper to the literature

- This paper examines the differences in job satisfaction between STEM and non-STEM novice teachers, and compares the differences in job satisfaction among elementary, lower secondary, and higher secondary STEM and non-STEM novice teachers.
- STEM NTLI focus more on professional development, autonomy in teaching, and the behavior of their students, whereas non-STEM NTLI focus more on participation in school policies. The findings will help schools and educational organizations identify the key factors for improving the experiences of STEM novice teachers and create appropriate policies for novice-teacher retention.

Teacher quantity and quality play key roles in improving STEM education, yet many schools and educational authorities encounter difficulties in recruiting certified STEM teachers (Hutchison, 2012). According to national data from the Schools and Staffing Survey (2012), only 38% of mathematics teachers ( $N=144,800$ ), 27% of science teachers ( $N=126,300$ ), 35% of biology teachers ( $N=51,900$ ), 62% of physical science teachers ( $N=64,600$ ), 66% of chemistry teachers ( $N=12,400$ ), 68% of earth sciences teachers ( $N=12,400$ ), and 63% of physics teachers ( $N=13,300$ ) have no major or minor in their main assignment or certification (Marder, Brown, & Plisch, 2017).

To improve the rate of teacher retention, administrators should focus on teacher job satisfaction since a highly positive correlation exists between teachers' job satisfaction and retention (Perrachione, Rosser, & Petersen, 2008; Wang, Hall, & Rahimi, 2015). The challenge, however, is to improve teachers' job satisfaction. Specifically, what factors contribute to teachers' job satisfaction and what are the differences between STEM and non-STEM teachers' job satisfaction? School administrators and policymakers can create and implement appropriate strategies to moderate and solve the shortage of certificated STEM teachers when they clearly understand the factors contributing to teachers' job satisfaction and teacher retention. For example, the Science Teacher and Research Program (Founded and implemented in 2007 by the Cal Poly Center for Excellence in Science and Mathematics Education on behalf of the California State University system), which focuses on strengthening STEM education for pre-service and early-career teachers, has three main goals: (a) increasing recruitment of high-quality teachers, (b) improving teacher education and in-service teachers' professional development, and (c) increasing the rate of teacher retention (Baker & Keller, 2008).

Although many studies have investigated possible factors and their relationships to teachers' job satisfaction (e.g., Liu, 2007; Liu & Meyer, 2005; Pearson & Moomaw, 2005; Shen, Leslie, Spybrook, & Ma, 2012; Smith & Ingersoll, 2004; Tickle et al., 2011), few studies have investigated the possible association between teacher background (teaching subjects, teaching grade levels) and job satisfaction. Motivated by the lack of research, this paper examines the effect of various factors that influence teachers' job satisfaction by analyzing a nationally representative database from the Schools and Staffing Survey (SASS) and targeting (a) STEM and non-STEM novice teachers with leaving intentions, and (b) elementary, lower secondary, and higher secondary STEM and non-STEM novice teachers with leaving intentions.

## LITERATURE REVIEW

The imbalance of supplement and attrition has led many researchers to investigate possible factors that influence teachers' decisions about continuing in their professions (Liu, 2007; Liu & Meyer, 2005; Pearson & Moomaw, 2005; Shen et al., 2012; Smith & Ingersoll, 2004; Tickle et al., 2011). Among the observed factors, job satisfaction has been identified as having a direct impact on teachers' decision-making (Liu & Meyer, 2005; Stockard & Lehman, 2004). Generally speaking, job satisfaction refers to the quality of working life (Shen et al., 2012). A positive attitude toward various aspects of the work experience and conditions such as school policy, working climate and classroom management, can effectively reduce stress levels and stimulate working motivations (Pearson & Moomaw, 2005).

Extensive studies have explored the factors associated with teachers' job satisfaction (e.g., Liu, 2007; Liu & Meyer, 2005; Pearson & Moomaw, 2005). Possible reasons for low job satisfaction among teachers have been attributed to working- and teacher-related factors, (Liu, 2007; Shen et al., 2012). Working-related factors are associated with a school's contextual and organizational features, including working climate, administrative and curriculum policies, available support, student characteristics, and school problems. Teacher-related factors are associated with teacher-perceived knowledge and competence in teacher-related activities such as teaching experiences, teaching self-efficacy, educational background, and professional development.

The contribution of school- or working-related factors has identified the significance of support from the school, working climate (e.g., student behavior and staff collegiality), and school policies (e.g., teacher autonomy in teaching and power in terms of school policies) in promoting teachers' job satisfaction (Shen et al., 2012; Tickle et al., 2011). According to Borman and Dowling (2008), administrative support refers to "the school's effectiveness in



assisting teachers with issues such as student discipline, instructional methods, curriculum, and adjusting to the school environment" (p. 380). Tickle et al. (2011), who investigated the impact of administrative support on job satisfaction among 34,810 regular full-time certified public school teachers, used a path model analysis with the variables of teaching experience, student behavior, teacher salary, administrative support, teachers' job satisfaction, and intent to stay in teaching. They found that administrative support was the most significant predictor of teachers' job satisfaction. They also reported the role of administrative support in mediating the effect of other variables (i.e., teaching experience, student behavior, and teaching salary) on teachers' job satisfaction.

The strong association between student behavior (i.e., the level or frequency of students' misbehavior) and job satisfaction has also been explored (Harrell & Jackson, 2004; Liu & Meyer, 2005; Smith & Ingersoll, 2004). Analyzing the SASS and Teacher Follow-Up Survey, Liu and Meyer (2005) explored the association between teachers' job satisfaction and factors such as discipline problems, school climate, professional support, compensation, and working conditions. The results of their hierarchical linear modeling indicated that student discipline problems were a major reason for dissatisfaction among teachers.

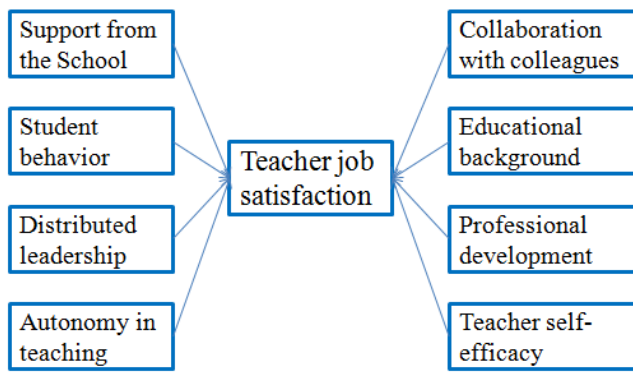
School-related factors of autonomy in teaching and distributed leadership in the school have also been identified as important indicators of job satisfaction. Teacher autonomy is concerned with the freedom to select teaching materials, teaching strategies, and teaching goals related to teachers' personal educational beliefs (Skaalvik & Skaalvik, 2014). Recent studies have identified a positive relationship between teacher autonomy and job satisfaction (Avanzi, Miglioretti, Velasco, Balducci, Vecchio, Fraccaroli, et al., 2013; Skaalvik & Skaalvik, 2009, 2010, 2014). Using regression analysis, Skaalvik and Skaalvik (2014) examined data related to 2,569 Norwegian teachers in elementary and middle schools. They found that teacher autonomy positively predicted job satisfaction.

Teachers are more satisfied with their jobs when they have more opportunities to participate in school policies (Bogler, 2001). According to Liu (2007), if first-year teachers knew they would be able to participate in administrative decision-making, they would prefer to stay longer in their jobs. For instance, Angelle (2010) reported that frequent distribution of leadership would improve teacher's intent of staying. Cerit (2009), who examined the effects of servant leadership of primary school principals on teachers' job satisfaction by collecting job satisfaction data from 595 teachers and 29 principals, found a strongly positive relationship between servant leadership and teachers' job satisfaction.

Several studies have investigated teacher-related factors for job satisfaction. Evidence from existing studies indicates that teachers' software, including colleague/staff collaboration, teacher self-efficacy, educational background, and professional development, may have an essential role in promoting teachers' job satisfaction (Cohen, McCabe, Michelli, & Pickeral, 2009; Shen et al., 2012; Taylor & Tashakkori, 1995). With respect to colleague/staff collaboration, the ability to communicate and collaborate with other teachers is a strong indicator for teachers to adapt to a new teaching environment (Tschannen-Moran, 2001). Analyzing 2,967 teachers and 178 principals from the Teaching and Learning International Survey (TALIS) 2008 data, Duyar, Gumus, and Bellibas (2013) found that teacher collaboration was the strongest predictor of job satisfaction.

In terms of teacher self-efficacy, prior studies have pointed to the existence of an unstable relationship between teacher self-efficacy and teachers' job satisfaction because teacher self-efficacy does not directly predict teachers' job satisfaction. According to Ware and Kitsantas (2011), self-efficacious teachers are more likely to be intrinsically motivated, actively participating in curriculum design and providing meaningful teaching activities for students. Consequently, teachers will exhibit good job performance and probably remain committed to their professions. Similarly, Wang et al. (2015) found that Canadian teachers with a higher self-efficacy level have greater job satisfaction. Reilly, Dhingra, and Boduszek (2014), however, who examined the role of teacher self-efficacy, self-esteem, and job stress in predicting the elementary teachers' job satisfaction, found no significant association between self-efficacy and job satisfaction.

Although several studies have investigated the relationship between certain teacher-related factors and teachers' job satisfaction, some aspects remain unexplored. Few studies have examined the possible influence of educational background on teachers' job satisfaction. As one aspect of teacher-related factors, the education experience and professional training in universities and colleges can be considered an indicator of teacher competence or efficacy. Thus, teachers with relevant educational background and strong training may experience less working pressure when preparing and conducting teaching activities. Shen et al. (2012) investigated the effect of a principal's background and school factors on teachers' job satisfaction. Although the study focused on the principal and school features, their theoretical model incorporated teacher and school background variables. Results from Hierarchical Linear Modeling found that school-level factors are strongly associated with job satisfaction among teachers. In addition, teacher factors, including teaching experience and teaching certificates, also have been found significant for job satisfaction (Shen et al., 2012). Regarding professional development, prior research has demonstrated that the frequency or opportunity of professional development was a significant factor for promoting job satisfaction (e.g., Kushman, 1992; Meek, 1998; Shann, 1998). A study by Guskey (2002) found that



**Figure 1.** The conceptual model of teacher job satisfaction

an effective systematic program on teachers' professional development helped to improve teachers' classroom teaching, teachers' attitudes and beliefs, and students' achievement.

Certain areas of teachers' turnover rate and job satisfaction remain largely uninvestigated, most prior studies have investigated either school-related factors or teacher-related factors, and relatively limited research has examined and compared the effects of school- and teacher-related factors on job satisfaction. Moreover, few studies have explored job satisfaction or leaving intentions among specific teachers (e.g., STEM teachers). Thus, differences in teaching subject, combined with factors such as school policy, educational background and teaching experience, may influence the preference of factors for job satisfaction among different teacher groups. Finally, only a handful of studies have examined teachers' job satisfaction with grade level (e.g., Klassen & Chiu, 2010; Perie & Baker, 1997; Skaalvik & Skalvik, 2011). It may be possible that teachers from various grade levels exhibit different levels of job satisfaction and preferences in specific school- or teacher-related factors.

### Purpose of the Study

The purpose of this study is to provide evidence so that policymakers and program developers can effectively address the shortage of STEM teachers and non-STEM teachers. The study expands upon the extant literature on teachers' job satisfaction as follows. First, as mentioned in the previous section, novice teachers were reported to have a relatively high tendency to leave their professions. Therefore, this study investigates novice teachers with leaving intentions who have less than two years of experience, and explores factors that may particularly influence their leaving intentions. Second, dividing novice teachers into STEM teachers and non-STEM teachers makes it possible to investigate the differences in factors and teachers' job satisfaction between the two groups, thereby providing insights into improving job satisfaction among STEM novice teachers. Third, subdividing the two novice groups into elementary teachers, lower secondary teachers, and higher secondary teachers makes it possible to examine the influence of grade level on the relationship between selected factors and teachers' job satisfaction.

The factors used in this study are based on a rich set of items in the national dataset, SASS 2011–12. School-related factors include school support, student behavior, autonomy in teaching, and participation in school policies. Teacher-related factors include teacher self-efficacy, educational background, and teachers' professional development. The conceptual model of job satisfaction shown in [Figure 1](#) is based on prior studies of the relationships between teachers' job satisfaction and school or teacher factors.

We fully explore the significant predictors for STEM novice teachers with leaving intentions (hereafter STEM NTLI) and compare the differences in job satisfaction between STEM and non-STEM NTLI to improve STEM NTLI job satisfaction. We pose three research questions: (a) Which factors are strongly associated with novice teachers' job satisfaction? (b) Do any differences exist between STEM NTLI and non-STEM NTLI in terms of the relationship between the factors and job satisfaction? (c) Do any differences exist between elementary, lower secondary, or higher secondary STEM NTLI and non-STEM NTLI in terms of the relationship between the predictors and job satisfaction?

## METHOD

### Data Source and Samples

The Schools and Staffing Survey (SASS) is an integrated study of public and private school districts, schools, principals, and teachers. SASS was conducted in the United States by the National Center for Education Statistics (NCES) seven times between 1987 and 2011. Its purpose was to provide the descriptive data necessary to create a

**Table 1.** Selected Factors, Measurements, and Reliabilities

Factor	Representation (items)	Coding	$\alpha$
Jb	Teacher job satisfaction (T0451 T0466 T0467)	Recode by using "1=4, 2=3, 3=2, 4=1, else=0," then, compute the mean. Continuous	.852
Sup	Support from the school (T0435 T0439 T0441 T0442 T0444 T0449)	Recode by using "4=0, 3=1, 2=2, 1=3, else=0," then compute the mean. Continuous	.814
Sbe	Student behavior (T0455 T0456 T0457 T0459 T0460 T0462 T0463 T0464)	Recode by using "1=4, 2=3, 3=2, 4=1, else=0," then, compute the mean. Continuous	.865
Dls	Distributed leadership in the school (T0420 T0421 T0422 T0423 T0424 T0425 T0426)	Compute the mean of all original variables. Continuous	.805
Aut	Autonomy in teaching (T0427 T0428 T0429 T0430 T0431 T0432)	Compute the mean of all original variables. Continuous	.755
Eff	Teacher Self-efficacy (T0211 T0212 T0213 T0214 T0215 T0216 T0217 T0218)	Compute the mean of all original variables. Continuous	.836
Pro	Professional development (T0339 T0340 T0342 T0343 T0345 T0346 T0348 T0349 T0351 T0352 T0354 T0355 T0356)	Recode T0356 by using "1=1, 2=0;" recode the others by using "1=1, 2=2, 3=3, 4=4, else=0, then compute the mean. Continuous	.766
Edu	Educational background (T0160 T0162 T0164 T0176 T0170 T0180 T0205 T0207 T0209)	Recode T0207 and T0209 by using "4=0, 3=1, 2=2, 1=3, else=0;" recode others by using "1=1, 2=0," then compute the mean. Continuous	.580
Coc	Collaboration with colleagues (T0364 T0365 T0366 T0452 T0445 T0443)	Recode T0443 T0445 T0452 by using "4=0, 3=1, 2=2, 1=3, else=0;" recode the others by using "1=1, 2=0," then compute the mean. Continuous	.540

Note. T0023 is the coder of the item in the *Teacher Questionnaire School and Staffing Survey 2011-12 School Year*

complete picture of American elementary and secondary education (NCES, 2016). This study is based on the Teacher Questionnaire-Schools and Staffing Survey 2011–12 School Year, which is part of the national dataset, SASS 2011–2012 available on the Institute of Education Sciences website (<https://nces.ed.gov/surveys/sass/question1112.asp>). From it we obtained general information, class organization, education and training, certification, professional development, working conditions, school climate, and teacher attitudes.

The sample is restricted to new teachers with leaving intentions from public schools. The new teachers had to meet three conditions: (a) They had to be regular full-time teachers, (b) Their work experience had to be less than two years, and (c) They had to have the intention of leaving the position of teacher. All teachers in the sample chose one of four options (until a specific life event occurs, until a more desirable job opportunity comes along, definitely plan to leave as soon as I can, undecided at this time) to answer the question: "How long do you plan to remain in teaching?" in the Teacher Questionnaire. We divided the teachers into STEM and non-STEM by using the questions: "This School year, what is your MAIN teaching assignment field at THIS school?" and "During your most recent FULL WEEK of teaching, approximately how many hours did YOU spend teaching each of the following subjects at the THIS school?" To classify the sample into three grade stages, we used: "Do you currently teach students in any of these grades at THIS school?" The final sample consists of 933 teachers (388 STEM and 545 non-STEM; 136 Pre-K-G5 teachers, 262 G6-G8 teachers, and 535 G9-12 teachers) without any missing data.

### Variables, Measures, and Descriptive Statistics

**Table 1** lists the selected variables. All variables are composite scores. We created the composite variable of teachers' job satisfaction based on three items selected from the section "School Climate and Teacher Attitudes" in the Teacher Questionnaire Schools and Staffing Survey 2011-12 School Year. The establishment of student behavior is based on eight items related to the question: "To what extent is each of the following a problem in this school?" Support from the school is based on six items related to the question: "To what extent do you agree or disagree with each of the following statements?" **Table 1** also lists the reliability measures for the composite variables. Internal consistencies of all variables are measured by the Cronbach alpha coefficient. All variables' coefficients are more than .75 except the variables of collaboration with colleagues and educational background. Their coefficients are .540 and .580, respectively. The relatively low coefficients might be due to the different scales of the items in the scales.

### Data Analysis Approach

We used multiple regression analysis and structure coefficient to find the factors strongly associated with novice teachers' job satisfaction. To compare the differences in two multiple regression models among different groups

**Table 2.** The Multiple Regression Weights, Structure Coefficients, and  $p$ -value from Overall Sample

Predictor	$\beta$	$r_s$	% of $R^2(r_s^2)$	$p$ -value
Sup	.564	.965	.932	.000
Sbe	-.122	-.588	.346	.000
Dls	.054	.583	.340	.036
Aut	.051	.432	.187	.031
Eff	.024	.289	.084	.275
Pro	.046	.187	.035	.031
Edu	-.003	.063	.004	.879
Coc	.143	.683	.466	.000
$R^2$	61.2%	$R^2_{adj}$	60.8%	

(STEM teachers and non-STEM teachers, grade stages, and both of them), we used Fisher's Z-test to examine whether the predictors contribute significantly differently to teachers' job satisfaction in two models, and Hotelling's T/ Steiger's Z-test to examine the differences in the structures of the two models (Hotelling, 1940; Steiger, 1980). We selected the most common formulas for  $SE_{b-difference}$  (Clogg, Petkova, & Haritou, 1995; Paternoster, Brame, Mazerolle, & Piquero, 1998) to examine the differences in the weights from the different models. The Fisher's Z-test and Steiger's Z-test were used to address the two research questions: (b) Do any differences exist between STEM NTLI and non-STEM NTLI in terms of the relationship between the factors and job satisfaction? and (c) Do any differences exist between elementary, lower secondary, or higher secondary STEM NTLI and non-STEM NTLI in terms of the relationship between the predictors and job satisfaction?

Multiple regression analysis determines which explanatory variables are statistically significant. We entered the following variables into the model: distributed leadership in the school, student behavior, autonomy in teaching, support from the school, collaboration with colleagues, teacher self-efficacy, educational background, and professional development. We checked the  $p$ -values of all predictors and obtained a multiple regression model. Regarding the differences in teachers' job satisfaction between STEM and non-STEM NTLI groups, we ran the multiple-group linear regression model to determine the differences between the two models' structures and weights. Although we easily found the different contributions of each predictor between the two models, we also used different Z-tests to determine whether the different were statistically significant.

## RESULTS

### Significant Predictors of Novice Teachers' Job Satisfaction

**Table 2** reports the results from the overall regression model. The multiple regression model with eight predictors explained the variation in teachers' job satisfaction ( $p < .001$ ) well. All eight predictors explained approximately 61% of the variance in teachers' job satisfaction. The standardized coefficients of teacher self-efficacy and educational background were .024, and -.003, respectively, but they were not statistically significant ( $p = .275$ ,  $p = .879$ ). The standardized coefficient of student behavior was -.122 ( $p < .001$ ). A significant negative relationship existed between teachers' job satisfaction and student behavior. The other predictors (support from the school, collaboration with colleagues, distributed leadership in the school, autonomy in teaching, and professional development in the past year) had positive significant relationships to teachers' job satisfaction. The most important contributor to teachers' job satisfaction was support from the school; the standardized coefficient of support from the school was 0.564. Collaboration with colleagues was also an important contributor; its standardized coefficient was 0.143.

**Table 2** also shows the structure coefficients of all predictors. A regression structure coefficient is the bivariate Person correlation coefficient of a measured predictor with the latent  $\hat{Y}$  scores (not with the  $Y$  scores, unless  $R^2 = 1.0$ ). Variables' collinearity does not affect the structure coefficient. Therefore, we could easily check the real contributions of all predictors. For example, even if the beta value of teacher self-efficacy in this model was not statistically significant, the value of the structure coefficient contributed 8.4% (.289<sup>2</sup>) to  $R^2$ . On the other hand, the value of the structure coefficient on professional development was .187, but its contribution was significant. From the perspective of structure coefficients, teacher self-efficacy was still an important predictor, while educational background slightly contributed to the  $R^2$ . It suggests that educational background was not a significant factor affecting novice teachers' job satisfaction.

### Differences between STEM NTLI and Non-STEM NTLI Job Satisfaction

**Table 3** lists the results of the multiple regression models for the STEM and non-STEM groups. According to the beta weights and  $p$  values, support from the school, student behavior, collaboration with colleagues, autonomy

**Table 3.** Beta Weights, Structure Coefficients, and *p*-value from STEM and non-STEM Groups

Factor	STEM				Non-STEM			
	<i>R</i> <sup>2</sup> (62.2%)		<i>R</i> <sup>2</sup> <sub>adj</sub> (61.4%)		<i>R</i> <sup>2</sup> (61.3%)		<i>R</i> <sup>2</sup> <sub>adj</sub> (60.7%)	
	$\beta$	<i>r</i> <sub>s</sub>	% of <i>R</i> <sup>2</sup> ( <i>r</i> <sup>2</sup> <sub>s</sub> )	<i>p</i> -value	$\beta$	<i>r</i> <sub>s</sub>	% of <i>R</i> <sup>2</sup> ( <i>r</i> <sup>2</sup> <sub>s</sub> )	<i>p</i> -value
Sup	.517	.944	.891	.000	.615	.978	.957	.000
Sbe	-.200	-.640	.409	.000	-.053	-.545	.297	.088
Dls	.022	.544	.296	.570	.085	.607	.368	.012
Aut	.085	.400	.160	.016	.011	.443	.196	.739
Eff	.021	.330	.109	.541	.026	.254	.065	.374
Pro	.072	.254	.065	.030	.024	.132	.017	.392
Edu	-.024	.072	.005	.470	.011	.036	.001	.691
Coc	.155	.700	.490	.000	.129	.667	.444	.000

**Table 4.** The Values of SE<sub>b</sub>-diff, Z-value, and *p*-value from Brame/Colgg Z-test

Factor	STEM		Non-STEM		SE <sub>b</sub> -diff	Z value	<i>p</i> -value
	<i>b</i>	SE <sub>b</sub>	<i>b</i>	SE <sub>b</sub>			
Sup	.595	.050	.744	.047	.06862	2.171	.030
Sbe	-.238	.043	-.062	.036	.05608	3.138	.002
Dsl	.030	.052	.109	.044	.06812	1.160	.246
Aut	.134	.056	.014	.042	.07000	1.714	.087
Eff	.032	.051	.035	.039	.06420	0.047	.963
Pro	.101	.046	.031	.036	.05841	1.198	.231
Edu	-.063	.087	.030	.076	.11552	0.805	.421
Coc	.269	.068	.240	.062	.09202	0.315	.753

in teaching, and professional development were statistically significant for STEM NTLI job satisfaction. In contrast, only support from the school, collaboration with colleagues, and distributed leadership in the school were statistically significant for non-STEM NTLI job satisfaction. According to the structure coefficient, distributed leadership in a school was an important predictor for STEM NTLI job satisfaction, while student behavior, autonomy in teaching, and professional development were significant for non-STEM NTLI job satisfaction.

**Differences between *R*<sup>2</sup> values.** The Fisher's Z-test showed that there was no statistically significant difference in the R-squared between the STEM and non-STEM models ( $Z = -.236, p > .05$ ), which indicates that the set of predictors predicted job satisfaction equally well for STEM and non-STEM teachers.

**Differences between model structures.** After use of Hotelling's T/Steiger's Z-test to compare structures for both models, the result ( $Z = 2.90, p = .002$ ) indicated that the multiple regression models of STEM and non-STEM NTLI had different structures, i.e., STEM and non-STEM novice teachers with leaving intentions emphasized different factors.

**Differences between predictors' contributions.** Although the difference in the weights of the two models was small, we used the Brame/Colgg Z-test to examine whether the differences were statistically significant. **Table 4** reports the results. Both student behavior and support from the school had significantly different regression weights in the STEM NTLI and non-STEM NTLI, while all other predictors had equivalent regression weights in the two groups. It suggests that education administrators should implement policies to improve STEM and non-STEM NTLI job satisfaction in terms of support from the school and student behavior.

### Differences between STEM/Non-STEM NTLI across Grade Stages

To further examine the moderation effect of grade levels, we tested the differences between STEM and non-STEM NTLI in the elementary, lower secondary, and higher secondary stages. **Table 5** reports the results. According to the beta weights from the STEM group, support from the school and student behavior significantly affected elementary teachers' job satisfaction; support from the school, student behavior, and collaboration with colleagues were statistically significant factors for lower secondary teachers' job satisfaction; and autonomy in teaching, support from the school, and student behavior were significant contributors to higher secondary teachers' job satisfaction. For the non-STEM group, support from the school, student behavior, and collaboration with colleagues were statistically significant factors for elementary teachers' job satisfaction; the contribution of support from the school was significant for lower secondary teachers' job satisfaction; and support from the school, distributed leadership in the school, and collaboration with colleagues were statistically significant factors for higher secondary teachers' job satisfaction.

**Table 5.** Beta Weights, Structure Coefficients, and *p*-value from Three Groups

Factor	Elementary			Lower secondary			Higher Secondary			
	<i>R</i> <sup>2</sup> (68.3%)			<i>R</i> <sup>2</sup> (70.0%)			<i>R</i> <sup>2</sup> (59.2%)			
	$\beta$	<i>r</i> <sub>s</sub>	<i>P</i>	$\beta$	<i>r</i> <sub>s</sub>	<i>p</i>	$\beta$	<i>r</i> <sub>s</sub>	<i>p</i>	
STEM	Sup	.536	0.928	.000	.429	0.885	.000	.536	0.939	.000
	Sbe	-.251	-0.712	.003	-.264	-0.692	.000	-.196	-0.615	.000
	Dls	-.095	0.429	.234	.006	0.492	.935	.070	0.599	.225
	Aut	.072	0.367	.347	.040	0.374	.523	.081	0.406	.122
	Eff	.007	0.373	.924	.054	0.395	.388	.003	0.233	.950
	Pro	.135	0.409	.112	.049	0.295	.399	.077	0.144	.109
	Edu	.058	0.167	.421	-.074	0.015	.214	-.006	0.046	.893
	Coc	.132	0.741	.138	.291	0.761	.000	.098	0.613	.087
Non-STEM	<i>R</i> <sup>2</sup> (78.0%)			<i>R</i> <sup>2</sup> (70.5%)			<i>R</i> <sup>2</sup> (57.3%)			
	Sup	.713	0.934	.000	.710	0.983	.000	.542	0.955	.000
	Sbe	.002	-0.548	.987	-.112	-0.677	.057	-.048	-0.504	.246
	Dsl	.047	0.622	.659	.008	0.564	.892	.124	0.620	.007
	Aut	-.057	0.394	.517	.016	0.354	.745	-.002	0.493	.963
	Eff	-.247	-0.046	.005	.056	0.287	.256	.067	0.293	.092
	Pro	.115	0.518	.182	-.051	-0.125	.287	.042	0.200	.267
	Edu	.106	0.183	.197	.051	0.146	.293	-.026	-0.047	.493
Coc	.198	0.612	.039	.040	0.649	.500	.160	0.683	.000	

**Table 6.** The Z-value and *p*-value from Fisher's Z-test

Group	<i>R</i> <sub>G1</sub>	<i>N</i> <sub>G1</sub>	<i>R</i> <sub>G2</sub>	<i>N</i> <sub>G2</sub>	Z-value	<i>p</i> -value
L1	.826	86	.883	50	1.171	0.121
L2	.837	105	.839	157	0.053	0.479
L3	.770	197	.757	338	0.346	0.365

Note. L1 = elementary STEM and non STEM NTLI; L2 = lower secondary STEM and non STEM NTLI; L3 = higher secondary STEM and non STEM NTLI

**Table 7.** The Z-value and *p*-value from Steiger's Z-test

Group	Direct <i>R</i> <sub>G1</sub>	Crossed <i>R</i> <sub>G2</sub>	Model correlation	<i>N</i>	Z-value	<i>p</i> -value
L1	.754	.826	.912	86	2.672	.004
L2	.754	.802	.889	157	2.111	.017
L3	.757	.740	.978	338	2.253	.012

According to the structure coefficient in the STEM group, all factors except educational background were important for elementary and lower secondary teachers' job satisfaction, while all factors except educational background and professional development were important for higher secondary teachers' job satisfaction. Based on the structure coefficient in the non-STEM group, all factors except educational background were important for elementary teachers' job satisfaction, while all factors except educational background and professional development were important for secondary teachers' job satisfaction. In general, educational background did not play an important role in predicting novice teachers' job satisfaction.

**Differences between *R*<sup>2</sup> values.** Table 6 reports the Z-value and *p*-value; all *p* values are more than 0.05. It suggests that the predictors in three different grade levels did equally well for STEM NTLI and non-STEM NTLI.

**Differences between model structures.** Table 7 reports the results. Different structures existed among the multiple regression models for predicting job satisfaction for elementary, lower secondary, and higher secondary STEM and non-STEM NTLI job satisfaction.

**Differences between predictors' contributions.** Table 8 reports the results. Teacher self-efficacy made significantly different contributions to job satisfaction between elementary STEM and non-STEM NTLI. Support from the school, student behavior, and collaboration with colleagues had significantly different regression coefficients between lower secondary STEM and non-STEM models. Student behavior had significantly different effects on job satisfaction between higher secondary STEM and non-STEM NTLI. The results provide evidence of the necessity to implement differentiated support and administration policies based on different field novice teachers as well as different grade stages.



**Table 8.** The Values of SE<sub>b-diff</sub>, Z-value, and p-value from Brame/Colgg Z-test

Factor	L1			L2			L3		
	SE <sub>b-diff</sub>	Z	p	SE <sub>b-diff</sub>	Z	p	SE <sub>b-diff</sub>	Z	p
Sup	0.202	1.585	0.113	0.125	2.608	0.009	0.094	0.374	0.708
Sbe	0.193	1.830	0.067	0.107	2.010	0.044	0.078	2.198	0.028
Dls	0.187	1.067	0.286	0.121	0.033	0.974	0.096	0.540	0.589
Aut	0.172	-1.116	0.264	0.124	-0.322	0.748	0.102	-1.336	0.182
Eff	0.164	-2.360	0.018	0.112	0.009	0.993	0.095	0.854	0.393
Pro	0.177	-0.006	0.995	0.117	-1.293	0.196	0.081	-0.644	0.520
Edu	0.373	0.485	0.628	0.219	1.629	0.103	0.156	-0.308	0.758
Coc	0.259	0.887	0.375	0.163	-2.577	0.010	0.128	0.837	0.402

## DISCUSSION

The results from the multiple regression model demonstrate that degrees of support from the school, student behavior, and collaboration with colleagues are strong indicators of the job satisfaction of novice teachers with leaving intentions, thus confirming the significance of school or contextual features. Although the results identify the significance of one teacher-related factor of collaboration with colleagues, most of the significant factors are school-related. The present study confirms earlier findings of the significance of school-related factors (e.g., Borman & Dowling, 2008; Stockard & Lehman, 2004). In our study, given limited teaching efficacy and experience, novice teachers appear to be more concerned about support from the school and a “less-stressful” working climate.

We also find that the two most significant factors contributing to teachers’ job satisfaction are support from the school and student behavior. Our results indicate that novice teachers may emphasize school environment in their profession. Thus, for novice teachers who are still developing teaching efficiency (e.g., teaching approach and classroom management), they are more willing to work in a less stressful, safe and comfortable environment. Therefore, supports in facilitating teaching and strengthening student rules from school are of great significance in helping them adapt to new working circumstances and promote their teaching efficacy and confidence (Baker & Keller, 2010; Kelly, 2004).

Collaboration with colleagues, which has also been identified as a strong component of job satisfaction, emphasizes the ability to communicate and collaborate with other teachers and staff. According to Kelly (2004), collaboration with colleagues plays an essential role in evaluating work satisfaction. Clearly, mutual understanding and cooperation with colleagues can boost working motivation, comfort and quality. Novice teachers’ ability to communicate and collaborate with other teachers is significant for teaching-related problem solving (Baker & Keller, 2010).

Our finding that self-efficacy and educational background do not significantly associate with job satisfaction differs from Klassen and Chiu (2000), who found a negative relationship between levels of teacher self-efficacy and levels of teaching grade and a positive relationship between teacher self-efficacy and teacher job satisfaction. The reason for the difference in findings may be attributed to different samples. As mentioned in the previous section, novice teachers valued working and contextual features (school factors) rather than individual factors because they were starting their teaching careers (Stockard & Lehman, 2004). Our findings support the idea that schools should reinforce service-oriented support for novice teachers, cultivate a friendly teaching and learning environment (i.e., well-behaved students) and strengthen cooperation and mutual help among teachers.

### Do STEM and Non-STEM NTLI Require Differentiation Strategies?

Comparing the differences in predictors’ contributions to STEM and non-STEM NTLI job satisfaction, results show that support from the school and collaboration with colleagues are strong indicators for both groups of teachers. In both groups of teachers, teacher-related factors including self-efficacy and educational background are not significant in determining job satisfaction. There are also differences in significant factors for job satisfaction between the groups; student behavior, teaching autonomy and professional development are strong indicators for job satisfaction among STEM teachers, while distributed leadership is strong among non-STEM teachers. The differences may be caused by teaching different types of subjects. Considering that STEM teachers teach calculation, high-level reasoning and problem solving, possibly they are more concerned about teaching delivery (e.g., classroom management, teaching design/plan, and teaching quality), whereas non-STEM teachers who teach social facts, history, and politics are more concerned about social climate, management and leadership. This finding may help school administrators understand the differences in career planning between STEM and non-STEM NTLI, but also poses a dilemma: Should administrators develop special support plans for STEM and non-STEM teachers, respectively? STEM NTLI appears more worried about the problem of student behavior unlike non-STEM novice

teachers. It suggests that the overall model can be divided into different sub-categories (e.g., STEM and non-STEM teachers, see Hodge, Jupp, & Taylor, 1994; Walker, Garton, & Kitchel, 2004), but more studies are needed.

Comparing the differences in each factor's contribution to job satisfaction for the two groups shows that the effect on job satisfaction of the strong predictor of support from the school is significantly stronger for non-STEM NTLI than for STEM NTLI. On the other hand, as previously mentioned, the effect of the predictor of student behavior on job satisfaction for STEM NTLI is significantly stronger than for non-STEM NTLI. It suggests that STEM education received more attention and support from the school and that STEM teachers addressed student behavior, which is a strong indicator for classroom management and teaching quality.

### **Should Strategies Be Differentiated across Grade Levels?**

Based on our three comparisons of the differences in predictors' contributions in the models of elementary, lower secondary, and higher secondary STEM and non-STEM NTLI, support from the school is the strongest factor affecting teachers' job satisfaction in all grade levels, and educational background and professional development are not statistically significant. It suggests that individual factors (educational background, professional development) have limited effects on the degree of job satisfaction. Our comparisons also show that the STEM and non-STEM NTLI models contain different structures at each stage. At the elementary level, student behavior strongly associates with job satisfaction in STEM NTLI, whereas self-efficacy and collaboration with colleagues are significant in non-STEM NTLI. At the lower secondary level, in addition to support from the school, student behavior and collaboration with colleagues strongly associate with job satisfaction in STEM-NTLI. At the higher secondary level, STEM teachers are more concerned about student behavior, whereas non-STEM teachers pay more attention to distributed leadership and collaboration with colleagues. As mentioned in the previous section, given the disparities of subject teaching, STEM teachers who teach calculation, high-level reasoning, and problem solving may be more concerned about classroom management. Elementary and lower secondary non-STEM teachers are more sensitive to support from the school on job satisfaction. It suggests that non-STEM teachers tend to leave their teaching positions when they obtain little support from the school. Differences in the model of teachers' job satisfaction between STEM NTLI and non-STEM NTLI across grade levels suggests the possibility of using "differentiation strategies" for STEM and Non-STEM teachers at different grade levels. Further studies should consider the role of grade levels (i.e., classifying teachers from different grade levels) on job satisfaction (e.g., Brackett, Palomera, Mojsa-Kaja, Reyes, & Salovey, 2010; Byrne, 1994).

## **CONCLUSION**

This study examined the relationships relating to job satisfaction in novice teachers with leaving intentions. Eight predictors were used for job satisfaction (support from the school, student behavior, leadership, teaching autonomy, teacher self-efficacy, professional development, previous education and training background, and collaboration with colleagues) for the STEM and non-STEM NTLI groups. The study explored predicting models with consideration of grade differences (i.e., elementary, lower secondary, and higher secondary levels).

Regarding novice teachers with leaving intentions, support from the school, student behavior, autonomy in teaching, professional development, and collaboration with colleagues were strong predictors of teachers' job satisfaction, with support from the school being the strongest factor predicting job satisfaction. Support from the school, distributed leadership, and collaboration with colleagues were strong predictors of job satisfaction for the non-STEM NTLI. Support from the school differed significantly between the STEM and non-STEM NTLI groups, i.e., STEM teachers placed more value on support from the school for their job satisfaction. Results from the predicting models across different grades revealed that support from the school was a significant factor affecting job satisfaction for elementary, lower secondary, and higher secondary STEM and non-STEM NTLI groups. Student behavior was a strong predictor of job satisfaction only for the STEM group across grades.

The findings provide several suggestions and implications for stakeholders (school administrators and policymakers) and researchers. School administrators and policymakers should provide a comfortable and safe school/working climate, and support teaching and strengthen school discipline for novice teachers adapting to a new working environment. Specifically, novice STEM teachers tended to be more sensitive to school environment and student behavior, with the consideration of limited teaching experiences and a strong emphasis on STEM at schools. Furthermore, administrators and school authorities should consider implementing different strategies for promoting teachers' job satisfaction at the various grade levels. For example, they could provide more opportunities for teachers to build collaborative relationships across subject and same subject across grade levels. Differentiated policies for different subjects and grade levels could help teachers' individualized professional development and teaching preferences. For example, non-STEM teachers could participate in school policies which foster a supportive school climate.

This paper has two limitations. First, only the mean was used to create composite scores for latent variables; and the reliabilities of collaboration with colleagues and educational background were somewhat low. Second, the data analysis showed only the linear regression results; thus, causal interpretation should be avoided. Therefore, researchers can further explore the issues that mentioned in the discussion. Studies can examine the relationship between different factors and job satisfaction with the consideration of grade level. Evidence from the present study indicates the different job satisfaction models for both STEM and non-STEM groups at different grade levels. Thus, the role of the grade level need to be further investigated using the latest national data. If the variables of educational background were categorical, future research could identify the differences in teachers' job satisfaction according to educational background. Finally, the present study only applied linear regression models, research can employ more advanced modeling (SEM or HLM) to explore the complicated relations and compare the differences and similarities of job satisfaction.

## REFERENCES

- Angelle, P. S. (2010). An organizational perspective of distributed leadership: A portrait of a middle school. *Rmle Online*, 33(5), 1-16. <https://doi.org/10.1080/19404476.2010.11462068>
- Avanzi, L., Miglioretti, M., Velasco, V., Balducci, C., Vecchio, L., Fraccaroli, F., & Skaalvik, E. M. (2013). Cross-validation of the Norwegian Teacher's Self-Efficacy Scale (NTSES). *Teaching and Teacher Education*, 31, 69-78. <https://doi.org/10.1016/j.tate.2013.01.002>
- Baker, W., & Keller, J. (2010). Science Teacher and Researcher (STAR) Program: Strengthening STEM education through authentic research experiences for preservice and early career teachers. *Peer Review*, 12(2), 22-26.
- Berry, B., Hoke, M., & Hirsch, E. (2004). The search for highly qualified teachers. *Phi Delta Kappan*, 85(9), 684-689.
- Bogler, R. (2001). The influence of leadership style on teacher job satisfaction. *Educational Administration Quarterly*, 37, 662-683.
- Borman, G. D., & Dowling, N. M. (2008). Teacher attrition and retention: A meta-analytic and narrative review of the research. *Review of Educational Research*, 78(3), 367-409. <https://doi.org/10.3102/0034654308321455>
- Brackett, M. A., Palomera, R., Mojsa-Kaja, J., Reyes, M. R., & Salovey, P. (2010). Emotion-regulation ability, burnout, and job satisfaction among British secondary-school teachers. *Psychology in the Schools*, 47(4), 406-417. <https://doi.org/10.1002/pits.20478>
- Byrne, B. M. (1994). Burnout: Testing for the validity, replication, and invariance of causal structure across elementary, intermediate, and secondary teachers. *American Educational Research Journal*, 31, 645-673.
- Cerit, Y. (2009). The effects of servant leadership behaviors of school principals on teachers' job satisfaction. *Educational Management Administration & Leadership*, 37(5), 600-623. <https://doi.org/10.1177/1741143209339650>
- Clogg, C. C., Petkova, E., & Haritou, A. (1995). Statistical methods for comparing regression coefficients between models. *American Journal of Sociology*, 100(5), 1261-1293.
- Cohen, J., McCabe, E. M., Michelli, N. M., & Pickeral, T. (2009). School climate: Research, policy, practice, and teacher education. *Teachers College Record*, 111(1), 180-213.
- Darling-Hammond, L., & Sykes, G. (2003). Wanted, a national teacher supply policy for education: The right way to meet the "highly qualified teacher" challenge. *Education Policy Analysis Archives*, 11(33). Retrieved from <http://epaa.asu.edu/epaa/v11n33/>
- Duyar, I., Gumus, S., & Bellibas, M. S. (2013). Multilevel analysis of teacher work attitudes: The influence of principal leadership and teacher collaboration. *International Journal of Educational Management*, 27(7), 700-719. <https://doi.org/10.1108/IJEM-09-2012-0107>
- Edgar, E., & Pair, A. (2005). Special education teacher attrition: It all depends on where you are standing. *Teacher Education and Special Education: The Journal of the Teacher Education Division of the Council for Exceptional Children*, 28(3-4), 163-170.
- Goldring, R., Taie, S., & Riddles, M. (2014). *Teacher attrition and mobility: Results from the 2012-13 teacher follow-up survey*. Washington, DC: National Center for Education Statistics. Retrieved from <http://nces.ed.gov/pubs2014/2014077.pdf>
- Guskey, T. R. (2002). Professional development and teacher change. *Teachers and Teaching*, 8, 381-391.
- Harrell, P. E., & Jackson, J. K. (2004). Redefining teacher quality: Myths of No Child Left Behind. *Teacher Education and Practice*, 17(2), 131-145.
- Hodge, G. M., Jupp, J. J., & Taylor, A. J. (1994). Work stress, distress and burnout in music and mathematics teachers. *British Journal of Educational Psychology*, 64(1), 65-76.

- Hotelling, H. (1940). The selection of variates for use in prediction with some comments on the general problem of nuisance parameters. *The Annals of Mathematical Statistics*, 11(3), 271-283.
- Hutchison, L. F. (2012). Addressing the STEM teacher shortage in American schools: Ways to recruit and retain effective STEM teachers. *Action in Teacher Education*, 34(5-6), 541-550. <https://doi.org/10.1080/01626620.2012.729483>
- Ingersoll, R. (2003). Is There Really a Teacher Shortage? *CPRE Research reports*. Retrieved from [http://repository.upenn.edu/cpre\\_researchreports/37](http://repository.upenn.edu/cpre_researchreports/37)
- Jones, G., Dana, T., LaFramenta, J., Adams, T. L., & Arnold, J. D. (2016). STEM TIPS: Supporting the beginning secondary STEM teacher. *TechTrends*, 60(3), 272-288. <https://doi.org/10.1007/s11528-016-0052-5>
- Kelly, S. (2004). An event history analysis of teacher attrition: Salary, teacher tracking, and socially disadvantaged schools. *The Journal of Experimental Education*, 72(3), 195-220.
- Klassen, R. M., & Chiu, M. M. (2010). Effects on teachers' self-efficacy and job satisfaction: Teacher gender, years of experience, and job stress. *Journal of Educational Psychology*, 102(3), 741-756. <https://doi.org/10.1037/a0019237>
- Kushman, J. W. (1992). The organizational dynamics of teacher workplace commitment: A study of urban elementary and middle schools. *Educational Administration Quarterly*, 28(1), 5-42.
- Liu, X. S. (2007). The effect of teacher influence at school on first-year teacher attrition: A multilevel analysis of the Schools and Staffing Survey for 1999-2000. *Educational Research and Evaluation*, 13(1), 1-16. <https://doi.org/10.1080/13803610600797615>
- Liu, X. S., & Meyer, J. P. (2005). Teachers' perceptions of their jobs: A multilevel analysis of the teacher follow-up survey for 1994-95. *Teachers College Record*, 107, 985-1003.
- Marder, M., Brown, R. C., & Plisch, M. (2017). *Recruiting teachers in high-needs STEM fields: A survey of current majors and recent STEM graduates*. Retrieved from American Physical Society: <http://www.aps.org/policy/reports/popa-reports/upload/POPASTEMReport.pdf> <https://doi.org/10.1119/1.4981053>
- Meek, A. (1998). America's Teachers: Much to Celebrate. *Educational Leadership*, 55(5), 12-16.
- Mollenkopf, D. L. (2009). Creating highly qualified teachers: Maximizing university resources to provide professional development in rural areas. *The Rural Educator*, 30(3), 34-39.
- National Center for Education Statistics (NCES) (2016). *Schools and staffing survey (SASS)*. Retrieved from <https://nces.ed.gov/statprog/handbook/pdf/sass.pdf>
- National Science and Technology Council (2013). *Federal science, technology, engineering, and mathematics (STEM) education 5-year strategic plan*. Retrieved from [https://obamawhitehouse.archives.gov/sites/default/files/microsites/ostp/stem\\_stratplan\\_2013.pdf](https://obamawhitehouse.archives.gov/sites/default/files/microsites/ostp/stem_stratplan_2013.pdf)
- Paternoster, R., Brame, R., Mazerolle, P., & Piquero, A. (1998). Using the correct statistical test for the equality of regression coefficients. *Criminology*, 36, 859-866.
- Pearson, L. C., & Moomaw, W. (2005). The relationship between teacher autonomy and stress, work satisfaction, empowerment, and professionalism. *Educational Research Quarterly*, 29(1), 37-54.
- Perie, M., & Baker, D. P. (1997). Job satisfaction among America's teachers: Effects of workplace conditions, background characteristics, and teacher compensation. *Statistical Analysis Report*. Washington, DC: U.S. Department of Education. Retrieved on August 4 2017 from <http://files.eric.ed.gov/fulltext/ED412181.pdf>
- Perrachione, B. A., Petersen, G. J., & Rosser, V. J. (2008). Why do they stay? Elementary teachers' perceptions of job satisfaction and retention. *The Professional Educator*, 32(2), 25-41.
- Reilly, E., Dhingra, K., & Boduszek, D. (2014). Teachers' self-efficacy beliefs, self-esteem, and job stress as determinants of job satisfaction. *International Journal of Educational Management*, 28(4), 365-378. <https://doi.org/10.1108/IJEM-04-2013-0053>
- Shann, M. H. (1998). Professional commitment and satisfaction among teachers in urban middle schools. *The Journal of Educational Research*, 92(2), 67-73.
- Shen, J., Leslie, J. M., Spybrook, J. K., & Ma, X. (2012). Are principal background and school processes related to teacher job satisfaction? A multilevel study using schools and staffing survey 2003-04. *American Educational Research Journal*, 49(2), 200-230. <https://doi.org/10.3102/0002831211419949>
- Skaalvik, E. M., & Skaalvik, S. (2009). Does school context matter? Relations with teacher burnout and job satisfaction. *Teaching and Teacher Education*, 25, 518-524. <https://doi.org/10.1016/j.tate.2008.12.006>
- Skaalvik, E. M., & Skaalvik, S. (2010). Teacher self-efficacy and teacher burnout: A study of relations. *Teaching and Teacher Education*, 26, 1059-1069. <https://doi.org/10.1016/j.tate.2009.11.001>

- Skaalvik, E. M., & Skaalvik, S. (2011). Teacher job satisfaction and motivation to leave the teaching profession: Relations with school context, feeling of belonging, and emotional exhaustion. *Teaching and Teacher Education*, 27, 1029-1038. <https://doi.org/10.1016/j.tate.2011.04.001>
- Skaalvik, E. M., & Skaalvik, S. (2014). Teacher self-efficacy and perceived autonomy: Relations with teacher engagement, job satisfaction, and emotional exhaustion. *Psychological Reports*, 114(1), 68-77. <https://doi.org/10.2466/14.02.PR0.114k14w0>
- Smith, T. M., & Ingersoll, R. M. (2004). What are the effects of induction and mentoring on beginning teacher turnover? *American Educational Research Journal*, 41, 681-714.
- Steiger, J. H. (1980). Tests for comparing elements of a correlation matrix. *Psychological Bulletin*, 87(2), 245-251.
- Stevenson, H. J. (2014). Myths and motives behind STEM (science, technology, engineering, and mathematics) education and the STEM-worker shortage narrative. *Issues in Teacher Education*, 23(1), 133-146.
- Stockard, J., & Lehman, M. B. (2004). Influences on the satisfaction and retention of 1st-year teachers: The importance of effective school management. *Educational Administration Quarterly*, 40, 742-771.
- Taylor, D. L., & Tashakkori, A. (1995). Decision participation and school climate as predictors of job satisfaction and teachers' sense of efficacy. *The Journal of Experimental Education*, 63(3), 217-230.
- Tickle, B. R., Chang, M., & Kim, S. (2011). Administrative support and its mediating effect on US public school teachers. *Teaching and Teacher Education*, 27(2), 342-349. <https://doi.org/10.1016/j.tate.2010.09.002>
- Tschannen-Moran, M. (2001). Collaboration and the need for trust. *Journal of Educational Administration*, 39(4), 308-331.
- Walker, W. D., Garton, B. L., & Kitchel, T. J. (2004). Job satisfaction and retention of secondary agriculture teachers. *Journal of Agricultural Education*, 45(2), 28-38.
- Wang, H., Hall, N. C., & Rahimi, S. (2015). Self-efficacy and causal attributions in teachers: Effects on burnout, job satisfaction, illness, and quitting intentions. *Teaching and Teacher Education*, 47, 120-130. <https://doi.org/10.1016/j.tate.2014.12.005>
- Ware, H. W., & Kitsantas, A. (2011). Predicting teacher commitment using principal and teacher efficacy variables: An HLM approach. *The Journal of Educational Research*, 104(3), 183-193. <https://doi.org/10.1080/00220671003638543>

<http://www.ejmste.com>



<http://www.ejmste.com>



<https://twitter.com/ejmste>



<https://www.facebook.com/ejmste>



<http://modestum.co.uk/>



[publications@modestum.co.uk](mailto:publications@modestum.co.uk)



## Training of Future Technology Teachers: Management Tools and Challenges in Current Educational Process

Olga Shatunova <sup>1\*</sup>, Elena Merzon <sup>1</sup>, Milyausha Shaimardanova <sup>1</sup>, Sergey Shabalin <sup>1</sup>

<sup>1</sup> Kazan Federal University, Elabuga, RUSSIA

Received 27 February 2018 • Revised 5 March 2018 • Accepted 6 March 2018

### ABSTRACT

Technological training is one of the most important components of the system of higher education in all economically developed countries. Objective of this research is revelation of effective management tools in the process of training of future teachers of technology. An experimental three-stage work with 102 students of Kazan Federal University in 2016-2017, directed to determination of level of professional competences formation, was carried out. The analysis of results of questioning and observations showed that the best result in training of teachers of technology is achieved by the tool, based on the use of a combination of means of formal, informal and non-formal education: case methods, business games, master classes, and discussions, participation of students in pedagogical and educational projects of the university. The educational business activity that allows simulating and playing any situation, connected with the organization of a new kind of activity, has to make a methodical basis of training a teacher of technology. The offered techniques can be considered as universal means of improvement of technological education quality.

**Keywords:** integrative science education; training of future technology teachers, formation of professional competences, informal and non-formal education, project-based learning

### INTRODUCTION

For technological modernization, contemporary society needs such experts, who are ready to join carrying out transformations for innovative economy (Bondi & Matthews, 2017). An important role in this process is played by the pedagogical education, focused on formation of such students' competences that will allow them to become not only highly qualified subject teachers, but also to act as mentors and assistants to children, considering individual features of every pupil (Casey & Childs, 2017; Depaepe & König, 2018; Lozano et al., 2017; Thomson et al., 2018).

Today in many highly developed countries there are cardinal changes in the system of training of future teachers (Bermus, 2015; Ilyina, 2014; Ozge, 2015; Schleicher, 2011). These processes are often directed to the strengthening of a practice-oriented content of training of students and formation of students' competences, necessary for future pedagogical activity (Jorgensen & Howard, 2005; Korshunova, 2015). In this regard, the main professional educational programs are revised; new profiles of training of future teachers are opened; essential amendments are put in programs of training disciplines and pedagogical practices (Avalos, 2011; Darling-Hammond, 2016; Elliott, 2011; Kalimullin & Gabdulkhakov, 2016).

Technology is a very capacious subject according to its practice and professionally oriented contents. It is focused on either teaching pupils to fulfil labor operations, techniques and elementary actions; or to preparing children for work planning (selection of materials, determination of the sequence of operations, the choice of tools, calculation of prime cost) (Auto & Soobik, 2013). Its main goal is formation of technological culture of a personality. The last acts as a certain criterion of readiness of a school graduate to succeed in the world of professions (Baser, Ozden & Karaarslan, 2017; Chalás, 2014). During technology classes, constructive labor of school students (creation

**Contribution of this paper to the literature**

- Revelation of effective management tools in the process of training of future teachers of technology is presented.
- Main professional competences of future technology teachers are defined.
- Proposed methods of formal, informal and non-formal education, applied in training of teachers of technology, are effective tools, which allow creating graduates' necessary professional competences.

**Table 1.** Number of the students who participated in the research

	Full-time education department		Distant education department	
	women	men	women	men
2nd course	13	1	-	-
3rd course	17	5	10	6
4th course	14	2	16	8
5th course	-	-	6	4

of a product on a creative reformatory basis), defining substantial essence of technological education in general, is organized (Patra, 2016; Sedov, 2016).

Organizationally, the subject "Technology" has to integrate in-class and out-of-class, school and out-of-school informative activities, main and additional, formal and informal education within educational school process (Pichugina, 2017; Reich, 2008). The idea to allocate in educational activity three directions (formal, informal and non-formal) began to be actively discussed after the Lisbon summit had taken place in 2000 (Robertson, de Azevedo & Dale, 2016). Until this time no attention to informal and non-formal education was paid, though formal education without two other forms hardly could be considered as sufficient for successful career and happy human life. Tripon (2014) argue informal and non-formal education have the psychological and pedagogical potential of a personality development, which is incomparable in opportunities.

Due to the increased requirements to personal and professional qualities of a teacher (Meijer et al., 2017), search for additional measures which would allow involving the brightest university graduates in teacher's activity (Gokce, 2014) and increasing appeal of the profession (Beach et al., 2014; Literature Review ..., 2010) is carried out.

So, the objective of our research is to analyse the principles of technology teachers training in the conditions of modernization of pedagogical education; and to provide universal models of the solution of the existing problems.

## METHODS

In 2016-2017, the complex research with participation of future teachers of technology directed to identification of effective instruments of formal, informal and non-formal education was organized and conducted. 52 students of full-time and 50 students of the distant education departments of the faculty of engineering and technology of Elabuga Institute of Kazan Federal University (the Republic of Tatarstan, Russia) participated in the research. In total, 76 girls and 26 young men aged from 19 up to 28 years (from the 2nd to the 5th courses) were invited to take part in the research (Table 1). All participants were informed on the purposes and phases of investigation. No one refused to participate in the activity.

We applied a method of cluster surveys with the subsequent continuous poll (Peña-Ayala, 2014). The number of respondents allows speaking about representativeness of this selection as the group of examinees is uniform.

The research was supposed to include observation, carrying out questioning and conversations with students (individual and group). 12 teachers were involved to the research: 1 professor, 7 associate professors, 3 senior teachers and 1 assistant.

At the first investigation phase, the involved teachers made observations in the groups, studying in full-time education department, in the course of the 1st semester of 2016 during classes. There were made records of changing of students' behavioural activity when using various methods of formal and informal education: discussions, business games, defence of papers and presentations. Level of certain competences formation was being defined in the course of conducting 8 credits and 4 examinations by means of the control and measuring materials, developed by each teacher, participating in the research, for every discipline. Cases, test tasks, control questions and tasks were used as a means of control and measuring materials.

Students of distant education department took part in the research during the sessions which were held in November, 2016 and March-April, 2017. Teachers also defined assessment of level of formation of competences during 4 control classes, 5 credits and 3 examinations.

**Table 2.** Self-assessment of students' level of formation of professional competences in the course of formal, informal and non-formal education

Professional competence	Middle score	Minimum score ( $\pm 0.2^*$ )	Maximum score ( $\pm 0.2$ )
readiness to realize educational programs on the subjects according to requirements of educational standards	7.4	4	9
ability to use modern methods and technologies of training and diagnostics	7.8	6	9
ability to solve problems of education and the spiritual and moral development, trainees in educational and extracurricular activities	8.3	5	10
ability to use opportunities of the educational environment for achievement of personal, metasubject and subject results of training and ensuring quality of teaching and educational process by means of the taught subjects	8.7	7	10
ability to carry out pedagogical maintenance of socialization and professional self-determination of students	8.9	5	10
readiness for interaction with participants of educational process	9.2	7	10
ability to organize cooperation of students, to maintain their activity, initiative and independence, to develop creative abilities	9.4	6	10

**Note:** the values in parentheses indicate the standard deviation

In parallel the teachers, participating in the research, observed students of full-time education within informal and non-formal education: in the course of their participation in various activities and projects of educational and pedagogical character – charity events on production of souvenirs, holding master classes in arts and crafts creativity for children and elderly people, organization of holidays for disabled children, assistance in decoration of class rooms in the children's creativity centers.

At the second investigation phase (first half of the year 2017), questioning of students was held. It assumed answers to the questions concerning assessment by students of level of formation of certain professional competences in the course of informal and non-formal education (participation in extra-curricular actions and projects). The level was supposed to be estimated according to a 10-mark scale. Questions were developed by authors. Irrelevant forms of answers did not appear. The statistical error made 2.1%.

At the third investigation phase (second half of the year 2017), results of questioning were analysed and generalized by means of methods of mathematical statistics; and the prospects of development of technological education were presented.

## RESULTS

During observations, it was revealed that those students, who participate in actions and projects within informal and non-formal education voluntarily, behave more actively during class activities: make reports more often than others, demonstrate higher level of knowledge during the discussions, and willingly undertake a role of moderators during business games and master classes. It was noted by 92% of the teachers involved in the research.

The analysis of answers of students is represented in **Table 2**.

Let us consider what specific tools in management of education of future technology teachers, according to the students and teachers, make effective impact on necessary professional competences formation.

Much attention in the course of training of students is paid to their economic and entrepreneurial training, as a result of which they receive practical skills of starting their own business, of the solution of tasks of the current business activity, of search for the new ideas and resources for business development. The methodical basis of training of the teacher of technology is made by the educational business activity allowing simulating and playing any situation connected with the organization of a new kind of activity including business, credibly imagining all possible consequences of the undertakings. Such activity turns to be productive, as it allows to connect theoretical and practical training, forms and develops the entrepreneurial culture of students (Shatunova & Shabalin, 2014).

Content of entrepreneurial training of future teachers of technology in the Russian higher education institution can be conditionally divided into two blocks (**Figure 1**).

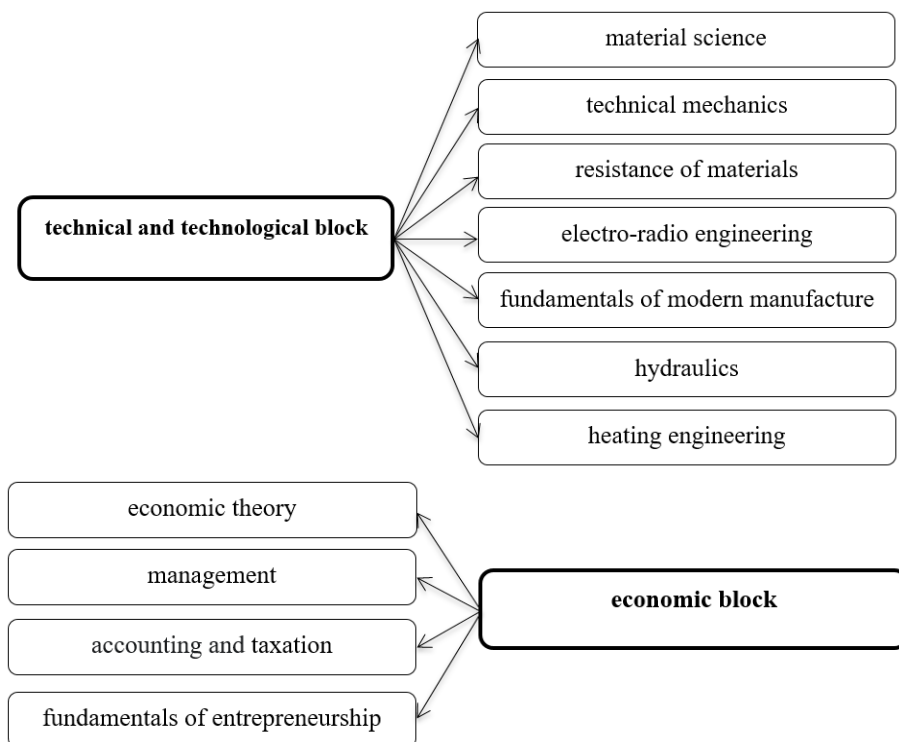


Figure 1. Stages of entrepreneurial training of future teachers of technology



Figure 2. Conducting games on entrepreneurship for senior pupils and students

At the same time, such training has to include a wide range of professional knowledge and practical abilities and also certain qualities of personality.

It should be noted that a very productive form of training of future teachers of technology is organization of unsupervised work of students for development of scenarios and methodical instructions for carrying out studies, games, out-of-class actions for various sections of the subject “Technology”. Future teachers work out their skills of teaching activity among their fellow students and junior students. The organization and holding of such actions requires a large number of illustrative means and materials, the electronic presentations, information databases. All this is also developed and made by students. So, at the engineering and technology faculty there are authored business games “Way of a Millionaire”, “Steps of Success”, “How to Make Business Plan”, “My Résumé”, etc. These games are successfully held at schools for senior pupils, and for students in educational institutions of secondary professional training (Figure 2). The high effectiveness of these forms of training of teachers was noted by 88% of students participating in the research.

Formation of professional competences of future teachers of technology is promoted also by their participation in interactive workshops, devoted to production of souvenirs. As a rule, work of such workshops is organized within the career counseling activities, held by the university at schools, rest camps for children and youth, at various fairs and festivals. Showing master classes devoted to design and arts and crafts, students, according to

their point of view, do not only show their skills and creative abilities, but also gain experience of educational work (89% of respondents have indicated efficiency of these actions).

As the research had revealed, carrying out master classes in design and arts and crafts creativity with children from rehabilitation centers, orphanages and with elderly people from retirement home turned out to be effective. Receiving experience of communication and work with these categories of the population, allows to create and develop new professional competences at future teachers (100% of teachers and 94% of students have noted efficiency of this form of training).

Discussions, conducted individually and in-group, have shown that students would like not only to participate in holding such actions, they also would like to take part in their development and preparation (84% of students). According to 90% of respondents, work of higher education institution, performed in the direction called "University for Society", is very useful and gives vast experience of communication and cooperation with various categories of the population – from children of preschool age to elderly people.

Results of the conducted research were considered during development of programs for vocational qualification training of teachers of technology. The devised program for advanced training course, focused on development of professional competences of teachers in the field of organization of school pupils' design activity, received positive reviews from audience. Its main advantage became holding a seminar, on which the performance of those colleagues, who have successful experience of implementation of projects, was supposed. At this seminar teachers can learn about the most effective forms of organization of design activity, methods of interaction of pupils with each other and with a teacher that promote development and further implementation of socially important projects.

Particular interest of the audience was arisen by the work forms, connected with creation of small factories on the basis of school workshops with granting job vacancies to physically disabled people; with production of clothes for children with light reflecting elements, which make them visible on the road at night-time; with elaboration and creation of souvenir products for tourists. Expansion of subjects of projects, involvement of all school students in design activity, improvement of its organization becomes a perspective task of teachers of technology.

## DISCUSSION

Organization of training of teachers at advanced training courses provided use of either traditional approaches (lectures, seminars, round tables), or innovative ones (games, discussions, on-the-job training). It is necessary to distinguish a master class from various forms of education. It provides mastering in practice skills of different types of practical activities or certain types of arts and crafts. Master classes are carried out both by teachers of faculty, and school teachers. Students – future teachers of technology are also very often invited to participate in these activities. The international practice shows that the atmosphere, created in these conditions, is characterised by high extent of creativity, as each participant of a master class does not just master technology, but also offers ways of its improvement or modification (Gansle, Noell & Burns, 2012; Howorth, Smith & Parkinson, 2012; Laclea et al., 2015; Long et al., 2012; Sotnik, 2016).

Realization at universities of various initiatives within innovative activity, at which students - future teachers of technology are recruited, can also be considered effective instruments of preparation. In Kazan Federal University, the educational project "Children's University", directed to popularization of scientific knowledge among junior school students, as well as to their intellectual development and expansion of mental outlook, serves as one of such initiatives. The children's university is open for all children, wishing to get acquainted with science. Lectures and practical classes which take place once a month on Sundays, are held by professors and associate professors, with the use of the latest educational technologies. Students of various faculties and the directions of preparation also take an active part in the organization of educational process at the Children's university. Future teachers of technology together with their tutors hold master classes for children in modeling and designing of various products from paper, fabric and other ornamental materials (Figure 3).





**Figure 3.** Master classes for children devoted to modeling and designing of various products

During these classes students gain experience of work with pupils of elementary grades, learn to organize the creative atmosphere in order to motivate children to creative activity, develop and improve their communicative abilities. The important role of this form of training was noted by 100% of teachers and 95% of the students who have participated in our research. It should be noted that, for example, in Japan students of pedagogical higher education institutions undergo similar practice in kindergartens, which present internship platforms for the universities (Suzuki, 2005).

The “Organization of Design Activity of School Students in Subject Area Technology” program became one more project for professional development for teachers of technology. Projects of pupils on technology can and have to become the instrument of achievement not only metasubject, but also subject and also personal results. It should be noted that authors, during drawing up the program, considered experiment of Great Britain on the organization of design training (Rasinen, 2003). Survey of teachers of technology, devoted to the problem of use of a method of projects in their practice, conducted in 2016, revealed the main difficulties, which they face. The problem of shortage of materials is noted by 37% of respondents, the weak material and technical resources as the reason of poor quality of school students’ projects are stated by 42% of teachers, the small number of academic hours, according to 68% of respondents, has also an adverse effect on results of design activity. Unfortunately, only 24% of teachers noted that for solution of the problem of increase in qualitative level of projects on technology they lack knowledge and methodical materials on the organization of design activity. The similar situation is characteristic practically for all Post-Soviet states (Smolentseva, Froumin & Huisman, 2017).

Technology can be regarded as a newcomer in education. Thus, in most Western countries technology education has been developed only in the past two or three decades (Kangas & Seitamaa-Hakkarainen, 2017). There is considerable variation between countries in how this subject is included in the curriculum and used in the classroom (Kelley & Sung, 2017). It is an interesting fact that in Great Britain technology at school, unlike in Russia, is considered the main subject, and the level of technological training of youth allows the state to be in the list of the most advanced countries for a long time. There teachers of technology pay special attention to endow pupils with such qualities which will allow them to become creative, critically thinking, mobile people capable to solve quickly arising problems and to create actual values taking into account individual and public requirements (Rasinen, 2003).

In the American education system the fact that the subject “Technology” is studied from kindergarten has already become a norm and surely assumes integration with other subjects including art. Such form of education is called STEAM (abbreviation from Science, Technology, Engineering, Arts, Mathematics) (Tarnoff, 2011).

In Germany, economy and education system of which, exert a noticeable impact on other states, technological training of youth differs in intensive character and a variety of extra high school programs (Reich, 2008). The dual education system that was accepted there, allows to provide a high level of proficiency of graduates of institutions of professional education, and creates conditions for successful social adaptation of youth (Falyakhov, 2015). All these factors as well as one of the highest level of public financing of the higher education in the world, caused very rapid growth of percent of gifted students who decided to continue their training in Germany, but not in domestic higher education institutions (Chankseliani, 2016; Habibov & Cheung, 2016).

However Russian and the western colleagues are united by the fact that nowadays pedagogical education is considered as a panacea for effective development of the whole education (Centurion, 2016; Valeeva, 2015). So, to improve the whole education system, first of all it is necessary to increase level of training of a teacher (Flores, 2016; König et al., 2017; Valeeva & Gafurov, 2017).



## CONCLUSION

To sum up, this experimental work showed that being involved in practical activities from the 1st course, future teachers start their pedagogical work more consciously. Moreover, they are better prepared for work with various categories of children and teenagers, elderly people; learn their psychological features; are able to use psychological and pedagogical means for this purpose. This fact was pointed to by more than 90% of the interviewed students.

Holding master classes by students, their active participation in pedagogical and educational actions and projects forms such professional competences as: ability to carry out pedagogical accompaniment of socialization and professional self-determination of students; readiness for interaction with participants of educational process; ability to organize cooperation of students, to maintain their activity, initiative and independence. Students' self-assessment of these formed competences made more than 8.9 points on a 10-mark scale (88% of students).

It gives grounds to claim that the offered methods and technologies of formal, informal and non-formal education, applied in training of teachers of technology, are effective tools, which allow creating graduates' necessary professional competences. With that, this research has some limitations. Thus, professional competences of 102 students were determined. Such a small sample can make broad generalization of results difficult. Large-scale control survey is needed to revelation of all the effective management tools in the process of training of future teachers of technology. This is a prerequisite for our further research on the problem.

## REFERENCES

- Auto, O., & Soobik, M. (2013). A Comparative Study of Craft and Technology Education Curriculum and Students Attitude towards Craft and Technology in Finnish and Estonian Schools. *Techné Series: Research in Sloyd Education and Craft Science A.*, 20(2), 17-33.
- Avalos, B. (2011). Teacher professional development in teaching and teacher education over ten years. *Teaching and teacher education*, 27(1), 10-20. <https://doi.org/10.1016/j.tate.2010.08.007>
- Baser, D., Ozden, M. Y., & Karaarslan, H. (2017). Collaborative project-based learning: an integrative science and technological education project. *Research in Science & Technological Education*, 35(2), 131-148. <https://doi.org/10.1080/02635143.2016.1274723>
- Beach, D., Bagley, C., Eriksson, A., & Player-Koro, C. (2014). Changing teacher education in Sweden: Using meta-ethnographic analysis to understand and describe policy making and educational changes. *Teaching and Teacher Education*, 44, 160-167. <http://dx.doi.org/10.1016/j.tate.2014.08.011>
- Bermus, A. G. (2015). Conceptual problems of the present stage of modernization of pedagogical education in Russia. *Continuous education: 21st century*, 2(10), 19-30.
- Bondi, L., & Matthews, M. H. (Eds.). (2017). *Education and society: studies in the politics, sociology and geography of education* (Vol. 9). London: Routledge.
- Casey, C., & Childs, R. (2017). Teacher education program admission criteria and what beginning teachers need to know to be successful teachers. *Canadian Journal of Educational Administration and Policy*, (67).
- Chalas, Kr. (2014). Technical Culture and Human Axjosphere. *Advances in Science and Technology Research Journal*. 8(24), 107-110.
- Chankseliani, M. (2016). Escaping Homelands with Limited Employment and Tertiary Education Opportunities: Outbound Student Mobility from Post-Soviet Countries. *Population, Space and Place*, 22(3), 301-316. <https://doi.org/10.1002/psp.1932>
- Darling-Hammond, L. (2016). Research on teaching and teacher education and its influences on policy and practice. *Educational Researcher*, 45(2), 83-91. <https://doi.org/10.3102/0013189X16639597>
- Depaepe, F., & König, J. (2018). General pedagogical knowledge, self-efficacy and instructional practice: Disentangling their relationship in pre-service teacher education. *Teaching and Teacher Education*, 69, 177-190. <https://doi.org/10.1016/j.tate.2017.10.003>
- Elliott, J. (Ed.). (2011). *Reconstructing teacher education* (Vol. 221). London: Routledge.
- Falyakhov, I. I. (2015). Organizational conditions of personnel quality assurance in German system of dual training. *Social Sciences*, 10(7), 1781-1784.
- Flores, M. A. (2016). Teacher education curriculum. In: J. Loughran, & M. L. Hamilton (Eds.), *International handbook of teacher education* (pp. 187-230). Dordrecht, the Netherlands: Springer.
- Gansle, K. A., Noell, G. H. & Burns, J. M. (2012). Do student achievement outcomes differ across teacher preparation programs? An analysis of teacher education in Louisiana. *Journal of Teacher Education*, 63(5), 304-317. <https://doi.org/10.1177/0022487112439894>

- Gokce, T. A. (2014). A Study on Unemployed Teacher Candidates Heading for a Different Profession. *Journal of Academic Social Research*, 2(1), 191-208.
- Habibov, N., & Cheung, A. (2016). The impact of unofficial out-of-pocket payments on satisfaction with education in Post-Soviet countries. *International Journal of Educational Development*, 49, 70-79. <https://doi.org/10.1016/j.ijedudev.2016.02.002>
- Howorth, C., Smith, S. M., & Parkinson, C. (2012). Social learning and social entrepreneurship education. *Academy of Management Learning & Education*, 11(3), 371-389. <https://doi.org/10.5465/amle.2011.0022>
- Ilyina, N. F. (2014). Modernization of continuous pedagogical education in the context of regional development. *SVFU bulletin*, 2, 124-128.
- Jorgensen, D., & Howard, P. (2005). Assessment for practice oriented education. In: *Proceedings of Third Annual Conference on Practice-Oriented Education*.
- Kalimullin, A. M., & Gabdulkhakov, V. F. (2016). Model of pedagogical education as a form of realization of strategic academic unit. *Education and self-development*, 2(48), 3-17.
- Kangas, K., & Seitamaa-Hakkarainen, P. (2017). Collaborative Design Work in Technology Education. *Handbook of Technology Education*, 1-13.
- Kelley, T. R., & Sung, E. (2017). Sketching by design: teaching sketching to young learners. *International Journal of Technology and Design Education*, 27(3), 363-386. <https://doi.org/10.1007/s10798-016-9354-3>
- König, J., et al. (2017). Effects of opportunities to learn in teacher preparation on future teachers' general pedagogical knowledge: Analyzing program characteristics and outcomes. *Studies in Educational Evaluation*, 53, 122-133. <https://doi.org/10.1016/j.stueduc.2017.03.001>
- Korshunova, V. V. (2015). Pedagogical education of bachelors: new standards. *Bulletin of the Adygei state university. Series 3: Pedagogics and psychology*, 1(157), 31-34.
- Lacleta, S. E., Luisa, M., Fidalgo Blanco, Á., & García-Peñalvo, F. J. (2015). Knowledge spirals in higher education teaching innovation. *International Journal of Knowledge Management (IJKM)*, 10(4). <https://doi.org/10.4018/ijkm.2014100102>
- Literature Review on Teacher Education in the 21st Century (2010). University of Glasgow. *Scottish Government Social Research*. 100 p.
- Long, M., Creech, A., Gaunt, H., Hallam, S., & Robertson, L. (2012). Blast from the past: Conservatoire students' experiences and perceptions of public master classes. *Musicae Scientiae*, 16(3), 286-306. <https://doi.org/10.1177/1029864912458848>
- Lozano, R., Merrill, M. Y., Sammalisto, K., Ceulemans, K., & Lozano, F. J. (2017). Connecting competences and pedagogical approaches for sustainable development in higher education: A literature review and framework proposal. *Sustainability*, 9(10), 1889. <https://doi.org/10.3390/su9101889>
- Meijer, M. J., Kuijpers, M., Boei, F., Vrieling, E., & Geijssel, F. (2017). Professional development of teacher-educators towards transformative learning. *Professional Development in Education*, 43(5), 819-840. <https://doi.org/10.1080/19415257.2016.1254107>
- Ozge, T. (2015). The State of In-Service Training of Teachers and Teacher Training in National Education Councils. *Procedia - Social and Behavioral Sciences*, 197, 378-381.
- Patra, R. (2016). Technological Culture and Human Subjectivity: Ethical Issues. *Asian Journal of Science and Technology*, 07(08), 3431-3438.
- Peña-Ayala, A. (2014). Educational data mining: A survey and a data mining-based analysis of recent works. *Expert systems with applications*, 41(4), 1432-1462. <https://doi.org/10.1016/j.eswa.2013.08.042>
- Pichugina, (2017). About realization of integration approach as prior direction of development of technological education of school students. *Strategy and tactics of training of the modern teacher in the conditions of dialogue space of education: Collection of scientific articles. Bryansk: BGU named after academician I.G. Petrovsky*. Pp. 270-274.
- Rasinen, A. (2003). An analysis of Technology Education Curriculum of Six Countries. *Journal of Technology Education*, 15(1), 31-47.
- Reich, G. (2008). The Development of Technology Education in Lower Saxony (Germany). *Bulletin of Institute of Technology and Vocational Education*, 5, 67-78.
- Robertson, S. L., de Azevedo, M. L. N., & Dale, R. (2016). Higher education, the EU and the cultural political economy of regionalism. *Global Regionalisms and Higher Education: Projects, Processes, Politics*. Cheltenham: Edward Elgar Publishing, Pp. 24-47.

- 
- Schleicher, A. (2011). The case for 21st century learning. Organisation for Economic Cooperation and Development. *The OECD Observer*, (282/283), 42.
- Sedov, S. A. (2016). Integration of the Quality Assessments of Vocational Teachers' Training. *IFTE 2016 - 2nd International Forum on Teacher Education*, 12, 185-189.
- Shatunova, O. V., & Shabalin, S. V. (2014). Innovative Training Forms of Pre-Service Teachers of Technology for the Teaching the Basics of Entrepreneurship. *World Applied Sciences Journal*, 29(4), 585-588.
- Smolentseva, A., Froumin, I., & Huisman, J. (2017). Transformation of higher education institutional landscape in post-Soviet countries: from Soviet model to where? In *25 Years of Transformations of Higher Education Systems in Post-Soviet Countries. Reform and Continuity*. Palgrave Macmillan.
- Sotnik, V. G. (2016). Modernization of pedagogical education in the Russian Federation. *Readings of Tsarskoye Selo*, XX, 143-146.
- Suzuki, S. (2015). Brought up with love: classical approach to education of talents: translation from English - M.: LLC Popurri. - 192 p.
- Tarnoff, J. (2011). STEM to STEAM. Recognizing the Value of Creative Skills in the Competitive [Digital resource]. Retrieved on 10.01.2017 from [http://www.huffingtonpost.com/john-tarnoff/stem-to-steam-recognizing\\_b\\_756519.html](http://www.huffingtonpost.com/john-tarnoff/stem-to-steam-recognizing_b_756519.html)
- Thompson, I. C., Willemsse, M., Mutton, T. A., Burn, K. C., & de Bruine, E. (2018). Teacher Education and Family-School Partnerships in different contexts: A cross country analysis of national teacher education frameworks across a range of European countries.
- Tripson, A. (2014). Innovative technology for sustainable development of human resource using non-formal and informal education. *Procedia Technology*, 12, 598-603.
- Valeeva, R. A., & Gafurov, I. R. (2017). Initial teacher education in Russia: connecting theory, practice and research. *European Journal of Teacher Education*, 40(3), 342-360. <https://doi.org/10.1080/02619768.2017.1326480>

**<http://www.ejmste.com>**



For print copies of this issue or articles please send an e-mail to:

[print@modestum.co.uk](mailto:print@modestum.co.uk)

## The Impacts of Teacher's Efficacy and Motivation on Student's Academic Achievement in Science Education among Secondary and High School Students

Seçil Bal Taştan <sup>1\*</sup>, Seyed Mehdi Mousavi Davoudi <sup>2</sup>, Alfiya R. Masalimova <sup>3</sup>, Alexandr S. Bersanov <sup>4</sup>, Rashad A. Kurbanov <sup>5</sup>, Anna V. Boiarchuk <sup>6</sup>, Andrey A. Pavlushin <sup>7</sup>

<sup>1</sup> Faculty of Business Administration, Department of Business Administration (Lecturing in English), Marmara University, Kadıköy, TURKEY

<sup>2</sup> Faculty of Management, Payame Noor University, Tehran, IRAN

<sup>3</sup> Institute of Psychology and Education, Kazan (Volga region) Federal University, Kazan, RUSSIA

<sup>4</sup> Department of Criminal Law, Criminal Procedure and Criminalistics, Peoples' Friendship University of Russia (RUDN University), Moscow, RUSSIA

<sup>5</sup> Department of Civil Legal Disciplines, Plekhanov Russian University of Economics, Moscow, RUSSIA

<sup>6</sup> Department of Humanitarian and Socio-Economic Disciplines, Moscow Higher Combined Arms Command School (MVOKU), Moscow, RUSSIA

<sup>7</sup> Department "Agro Technologies, Machines and Life Safety", Ulyanovsk State Agrarian University named after P.A. Stolypin, Ulyanovsk, RUSSIA

Received 8 June 2017 • Revised 24 October 2017 • Accepted 25 November 2017

### ABSTRACT

In the 21st century, we observe an increasingly aware of a series of global, technological and scientific advancement that create a need of good performance in science education at all levels of schooling. These challenges, among them rapid science and technological changes, a rise of information technology use, and continuing movement towards a knowledge-based society all highlight the need for deep education in science including biology, chemistry, environmental science, physics, and sustainability. In fact, the impact of teacher characteristics of self-efficacy level is important for science education and students' learning outcomes in science. In an effort to highlight this, this study investigated the impacts of teacher efficacy and motivation on students' academic achievement in science education in secondary and high schools located in Iran and Russia using motivation for academic performance scale ( $\alpha = 0.89$ ) and teacher self-efficacy scale ( $\alpha = 0.91$ ) as measuring instruments and achievement test in science education. Two hypotheses were tested using the statistical programme. For evaluating the demographical differences of the students in terms of their academic achievement, comparative analyses were performed using t-test. Results showed that gender difference was not significant but nationality difference was significant in terms of students' academic achievement in science education. Also other findings reported significant impact of teacher self-efficacy and motivation on academic achievement in science education. Implications, suggestions and recommendations for students, teachers, school administrators, parents, government, education counselors, etc. were discussed and presented.

**Keywords:** teacher self-efficacy, learning motivation, academic achievement, learning outcome, science education

#### Contribution of this paper to the literature

- This research considers teacher's efficacy and students' learning motivation on their academic achievement in science education which have been missed in earlier studies.
- The current study bolds the role of student's learning motivation in science education.
- The results of the current study provide further insights for managers of schools, teachers, policy makers, etc. in improving student's academic achievement by proposing new effective factors combining both teacher and student's motivation.

## INTRODUCTION

In the contemporary nations, there has been an increasing emphasis on industrial, scientific and technological advancements because of the obvious effects of science and technology on today's world and the future. It is observed that scientific methods influence all human interaction and has a fundamental role in all countries' national growth and economic and scientific development. Thus, science education has been regarded as being central for knowledge economy and intellectual development especially in emerging societies. Due to greater importance of science and technology, schools have been encouraging students to learn science related subjects. Specific subjects that are studied within all types of sciences are biology, chemistry, physics, sustainability and environmental science. Accordingly, we suggest that scientific and technological advancement in a country can be initially achieved through the high performance of students in science education and the efforts of schools for establishing efficient science education. Besides, it is thought that one of the greatest challenges of this century is to motivate students for maintaining their learning and success in science education. However, as mentioned by the studies of Tella (2007) and Ochonogor (2011), students' performance in science classes in secondary and high school education was not found adequate and couldn't improve in the last decade. In previous researches, various background indices and a set of complex variables have been referred to impacting students' achievement in science subjects in schools at all levels. The students' performance and interest in science subjects have been related to several contextual, emotional and motivational factors, including volume of the subjects, workload, students' task orientation and personal abilities, instructional design and materials for effective teaching, teacher's efficacy and teaching skills, students' motivation and personality, class size, etc. (Abbasi et al., 2018; Ale, 1989; Armstrong, 2009; Bietenbeck, 2011; Ehrenberg, Brewer, Gamoran, & Willms, 2001; Harris & Sass, 2008; Kirillova et al., 2017; Kwon, 2016; Odogwu, 1994; Ohuche, 1978; Rus, Radu & Vanvu, 2016; Say & Bag, 2017; Shcherbakov et al., 2017; Wang & Hsieh, 2015).

In fact, science education is usually abstract and complicated, thus, teaching science may require special attention and efficacy of teachers in order to better attract students and teach the subjects through concrete and clear methods. As Ruby (2001) emphasized, teachers may use hands-on science and laboratory studies for providing students much more concrete illustrations of the science knowledge and increase their analytical skills in science. It is argued that clarifying these process skills and developing efficient teaching methods affect achievement in science education. Another concern regarding students' learning and achievement in science is enhancing students' ability to evaluate and measure the scientific knowledge through the use of individual problem solving skills and to promote them to execute scientific examinations on their own. Actually, this goal requires teachers' skills and efficacy, students' motivation for learning in science and high quality instructional approaches for interpreting scientific knowledge. Such an argument has been maintained by Bietenbeck (2011) who stated that "teachers matter" (p.1) and characteristics of the teacher establish the learning motivation of the science students. This is also the consensus from a wide range of studies which investigate the impact of teachers on students' academic performance (Rockstroh, 2013; Armstrong, 2009; Clotfelter et al., 2007; Harris & Sass, 2008; Wayne & Youngs, 2003). An empirical support comes from the study of Clotfelter, Ladd, & Vigdor (2007) in which they found significant strong positive relationship between teacher experience and efficacy and student achievement while. Rockstroh (2013) also indicated that teachers are among the predominant school-based factors in impacting student's achievement at all branches of science education.

Thus, it is suggested that knowing what teacher characteristics in terms of teaching skills of science and self-efficacy influence student achievement in science education may help school administrators and governmental officers to understand the importance of priority of hiring and assigning appropriate teachers to science classes. Based on that view, the purpose of this study is to find answers for two basic questions. The first question is whether teacher's self-efficacy as one of the teacher characteristics is related to student achievement in science education; the second is whether students' learning motivation is related to their achievement in science education. Another question of the study is whether there are differences in student achievement in science based on student gender and nationality. A review of teacher self-efficacy, student motivation, and differences in national backgrounds provides some background of the relationship among teacher self-efficacy, motivation and student achievement in



science. Based on the presupposed relationships, the literature review for the concepts of the study and previous theoretical and empirical perspectives on the issue were introduced in the following parts for elucidating the theoretical background of the study.

## LITERATURE REVIEW AND DEVELOPMENT OF THE HYPOTHESES

We find requisite to describe the concepts of teacher self-efficacy, motivation for learning science, and academic achievement of students conceptually and to provide knowledge for the relevant background theories comprising the context of this study. Therefore, a brief review of each of these concepts and their interactional relations can reveal similar predictions about how the students achieve in science education in secondary and high schools. As a result of the examination on theoretical foundations, to elicit more comprehension for the individual differences and contextual factors in science-related achievement, we examined the relationship between these individual differences (learning motivation, gender and nationality) and contextual factor (teacher self-efficacy). Thus, this section will define the variables used in this study; teacher self-efficacy, motivation and academic achievement in science. Following the conceptual definitions of the variables and the suggested associations among these variables, the generated hypotheses for the aim of this study will be provided.

### Learning Motivation and Science Education

In making instruction interesting in learning science, there is need to use methods, strategies, materials, equipments, laboratory and visual aids which make the learning of science, active, investigative and adventurous for the students as much as possible. Such methods also must be ones that take into account, student's differences, backgrounds, and motivational attitudes towards science as a subject. It is known that to destine a student to reach his/her goals is the internal drive which is called as motivation. As Singh (2011) indicated, motivation creates a self determination and a feeling of enthusiasm that leads a student to realize greater meaning and objectives in personal and academic processes. In fact, the issue of learning and achievement motivation is still a relevant topic in psychology and educational research. As implied by Poledřnová, Stranska and Niedobová (2014), social-psychological approach considers a person's interactions in social relationships and denotes how these relationships enable the person's achievement orientation.

As known from the motivation literature, the drive may be internal or external and the factors that motivate a student may change depending on the change in age and social development. Motivation is generally described as internal condition that stimulates, directs and sustains human behavior. Besides, as Maslow (1955) indicated, the goal that has been achieved sets the situation for achieving another goal. Further, both content and process theories of motivation mainly focus on the factors that direct human behavior and they are essential for the evolvement and achievement of personal goals. Maslow's (1955) hierarchy of needs, Alderfer's ERG theory, McClelland's (1995) learned needs theory, and Herzberg's motivator-hygiene theory are among the content theories. Thus, motivation is a constant need that leads a student to act towards a goal since motivation enables a behavior to be energized towards a goal. There is permanent literature that demonstrates a strong association between student motivation and learning. As Mazumder (2014) addressed, the motivation level is important to effectuate in challenging conditions, stay focused on goals and to accomplish difficult tasks. It is obvious that for each student the type of driving force is different, and usually it is not only one factor, but a combination of factors that lead students to achieve their goals. Even though, to succeed in science education, a student must have a higher level of motivation towards learning and developing skills to achieve performance in science.

There are several approaches to the subject of achievement and learning motivation. Spence and Helmreich (1983) defined achievements as task-oriented behavior. The pioneering definition of achievement motivation is from Atkinson (1964) and he defined it as the comparison of one's performance with other's performance in certain activities. Bigge and Hunt (1980) described achievement motivation as the drive to work with vigor, to focus on goals, to come over challenging tasks and finally to develop learning and achievement. Another considerable perspective in student motivation research is goal orientation theory. According to the assertion of achievement goal orientation theory (Elliot and McGregor, 2001), when students hold academic tasks, they set various personal goals and the types of their goals directly impact their academic achievement. In their research, Noar, Anderman, Zimmerman and Cupp (2005) demonstrated that the students who had mastery goals engaged in more effective cognitive processing strategies. Another research reported that achievement motivation and self concept were significantly associated with academic achievement of students in mathematics (Awan, Noureen, & Naz, 2011). Further, it is assumed that the assessment of implicit motives of students might help to evaluate the appropriateness of students' long-term goals and their academic achievement in science education. Supporting this assumption, Ward (1997) argued that individuals with high achievement motivation are focused on achievement goals and are generally proactive. According to Zenzen (2002), the students are effected by a need to achieve to a certain level and the students having a high desire of success, work harder to succeed (p.10). Steinmayr and Spinath (2009)

performed a research and reported the significant relation between need for achievement and student performance. Besides, Murray's (1938) famous theory of "manifest needs" postulated the need for achievement as a fundamental one in his taxonomy of needs. In such, according to the above literature, it is seen that achievement motivation is a subjective and internal psychological state which enables students to value their school tasks, to focus on their targets, and to carry out the challenging requirements of science classes. Based on the quoted research review, the achievement motivation has essential role in predicting achievement or failure of students in science education. Thereby, achievement motivation for science education seems to be a very important issue owing to today's society's focus on development and success.

Instantly, it is assumed that academic achievement of the student in science is not solely influenced by the achievement motivation but is shaped by other factors such as teacher's self-efficacy. Since it has been addressed that the students are impacted by achievement motivation, they may also be influenced by the motivation of their teachers. Through efficient training method, the teacher can motivate and lead students to concentrate on the accomplishment of the science related tasks. It is suggested that teachers are able to increase the perceived value of the science classes and may guide the students to gain effective learning outcomes. Thereby, the impact of teacher characteristics of self-efficacy is important for education and learning of students. Along with this view, Wayne and Youngs (2003) told that a large body of literature about teacher self-efficacy and education outcomes exists. Ensuring that teachers with high self-efficacy are most able to enhance student achievement, the following part will provide insights for understanding the relation of teacher self-efficacy with student achievement.

### **Teacher's Self Efficacy and Student Academic Achievement**

Derived from Bandura's (1997) socio-cognitive model, self-efficacy is defined as one's belief about his/her ability and capacity to do a task or cope with environmental demands. In the work context, self-efficacy is measured as a person's self-evaluation of his/her ability to come over the demands of work conditions (Bandura, 1997). Based on the perspective of social cognitive theory, human agency is mediated by an individual's level of self-efficacy and such a belief impacts the person's emotional state, choices, efforts and resilience when the person faces any challenging situation (Pajares, 1996). The self-efficacy literature indicated that self-efficacy belief also has an important role in psychological and physical health outcomes. For instance, people with high self-efficacy reported lower levels of perceived work stress and strain, and reported less physiologic stress response (O'Leary, 1992). Within the occupational literature, it was stated that low self-efficacy had significant relation with high levels of stress, anxiety and depression (Ghaderi & Salehi, 2011; DeWitz, Woolsey, & Walsh, 2009; Jex & Dudanowski, 1992; Ehrenberg, Cox, & Koopman, 1991). Moreover, high self-efficacy influenced job satisfaction and well-being positively but had negative influence on turnover rates (Nielsen, Yarker, Randall, & Munir, 2009; Stetz, Stetz & Bliese, 2006; Zellars, Hochwarter, Perrew, Miles, & Kiewitz, 2001). A research performed by Caroli and Sagone (2014) has revealed that there was a positive association between perceived generalized self-efficacy and psychological well-being.

The studies examining self-efficacy beliefs in educational settings have demonstrated that people with high self-efficacy are more likely to undertake a proactive approach when faced with stressful situations and perform more role responsibilities than the people with low self-efficacy (Le, Casillas, Robbins, & Langley, 2005; Chemers, Hu, & Garcia, 2001; Pajares & Valiante, 1999). Educationally, self-efficacy belief was investigated in the context of academic performance and self-regulated learning (Henson, 2001; Pajares, 1996; Zimmerman, 1995; Hackett, 1995). The literature confirms the association between students' self-efficacy beliefs for academic works and their academic achievement. The researchers have explored the academic self-efficacy beliefs' role in school success of the students. For example, the study of Gore (2006) found that self-efficacy beliefs moderated the relationship between academic self-efficacy beliefs of the students and their school success.

Consistent with the general conceptual definition of self-efficacy, teacher self-efficacy has been defined as a teacher's evaluation of his/her capabilities to enable desired outcomes of student engagement learning and performance (Tschannen-Moran, Woolfolk Hoy, & Hoy, 1998). Based on the implications of social cognitive theory, teachers' self-efficacy beliefs have been related with effective teaching behaviors and performance levels of students. Bandura's (1997) research studies concluded that a teacher's belief about his/her competency and potential to teach students had significant impact on the achievement of the students. We also suggest that the teacher's self beliefs including self-efficacy have crucial roles in the classroom environment and the effectiveness of student learning. On the other side, we argue that self-efficacy of the teachers will not only impact students but the entire school organizational system. Supporting this argument, Ball (2010) identified that teachers' self-efficacy create collective efficacy, which influence the whole school system. Further, as claimed by Porter and Brophy (1988), the teacher having high self-efficacy would be more efficient in providing a climate for learning. It was also noted that the teacher has important roles in managing the classroom, in enhancing the students to find the tasks more meaningful and in implementing effective learning strategies (Cardenas & Cerado, 2016). Ultimately, teachers with high self-efficacy tend to use more interactive teaching methods and utilize contemporary instructional methods.

Researchers agreed in suggesting that the core element of pedagogy is the amount and intensity of student engagement in classroom activities and in learning tasks (Cardenas & Cerado, 2016; Rink, 2013; Rivkin, Hanushek & Kain, 2005; Gusthart & Springings, 1989). Further, it was stated that teachers' self-efficacy impacted student achievement positively, enabled the teachers to perform better planning and organization facilities (Gowrie & Ramdass, 2014). Based on Rotter's (1966) locus of control theory, it was argued that student learning and motivation were the outcomes of teacher's self-evaluations. Students of efficacious teachers generally have outperformed students in other classes; Teacher self-efficacy was predictive of achievement on the Iowa Test of Basic Skills (Moore & Esselman, 1992), the Canadian Achievement Tests (Anderson, Greene, & Loewen, 1988), and the Ontario Assessment Instrument Pool (Ross, 1992). Teacher self-efficacy was also related to students' own sense of efficacy (Anderson et al., 1988) and student motivation (Midgley, Feldlaufer, & Eccles, 1989). Furthermore, teacher self-efficacy was found to be associated to positive teaching behaviors and strong student achievement since teachers having high self-efficacy used open-ended questions, interactive learning, inquiry methods, and group learning activities in the classroom (Gavora, 2010). More specifically, it is stated that such teachers are more resilient and had tendency to take risks and to use newly adopted methods, and are more innovative in teaching science, mathematics and technology (Schunk & Pajares, 2001; Ross, 1992; Midgley et al., 1989). Other researchers also indicated that teachers with high self-efficacy are more open to adopt new opinions and innovative techniques, support students' initiation and autonomy, and to improve the interest of the students towards science (Brouwers & Tomic, 2003; Ross & Bruce, 2007). As Gavora (2010) stated, teacher self-efficacy can be seen as a strong self-regulatory characteristic that enables teachers to use their potentials to enhance students' learning. Further, previous research has found that teacher self-efficacy had impact on the students' motivation and achievement (Mojavezi & Tamiz, 2012; Stipek, Givvin, Salmon, & MacGyvers, 1998; Wentzel, 1998). Alvares-Nunez (2012) confirmed that teacher self-efficacy was the predictor of primary school students' achievement in mathematics. Accordingly, it is suggested that teacher self-efficacy is an important characteristic of the teacher that is strongly related to success in teaching challenging academic tasks such as science education.

## THE PURPOSE AND HYPOTHESES OF THE STUDY

This study sought to explain achievement outcomes of secondary level and high school students in science education in terms of teachers' self-efficacy and motivating students towards academic gains in the subject. Based on the review of literature, the following hypothesized relationships including the study variables are suggested.

- H1:** Teacher's self-efficacy has a positive impact on students' academic achievement in science education.
- H2:** Motivation for learning science has a positive impact on students' academic achievement in science education.

Further, in this study, we tested two null hypotheses with the significance level at 0.05 margin of error. They are as follows:

- H01:** There is no significant difference in the academic achievement of male and female students in science education.
- H02:** There is no significant difference in the academic achievement of students in science education in terms of their national background.

## METHODOLOGY

### Design and Procedure

The study used a cross-sectional questionnaire survey design. The participants of this study include two groups: the first group consisted of senior secondary and high school teachers in four different cities of Iran and four different cities of Russia. The second group of participants includes students in the same schools of the teachers. The students actually belonged to the science classes (biology, chemistry, physics, environmental science, and sustainability) whose teachers participated in this study. The students were asked questions about their learning motivation and achievement in science classes. Questionnaire research in

Iran and Russia requires approval by ethic committees and thus the study was approved for following the regulations for data confidentiality. In addition, we informed the participant groups about the purpose and procedure of the research study before they completed the questionnaire, so that voluntary participation has been secured. At last, the participants gave in the completed questionnaires to the researchers directly.

## Sampling Procedure and Sample

In the survey, 440 secondary school and 350 high school students drawn from 15 schools in two countries of Iran and Russia. Some of the participants gave multiple responses to single items, thus we accepted them as unanswered, and excluded them for eliminating the threats for further analysis. As a result, as counted for the usable questionnaires, totally 790 students participated in the study. This sample of students was randomly drawn from selected schools. Their age ranged from 12-20 years with a mean of 15.5 years and standard deviation (SD) of 3.6. The study included male (64.8%; SD=10.93) and female students (35.2%; SD=12.88). Besides, totally 350 teachers educating in science classes participated including male (56%) and female (44%) teachers. The mean age of the teachers was 35.93 (SD= 5.65) and their average years of experience was 12.16.

## Instrumentation

In this study, for measuring teacher's self-efficacy belief, "Teacher Self-Efficacy Questionnaire" developed by Tschannen-Moran and Hoy (2001) was utilized. The questionnaire, includes 24 items which were assessing the teacher's belief about his/her effective control over Instructional Strategies (8 items), Classroom Management (8 items), and Student Engagement (8 items). In the original study, the three component scale used a 5-point Likert scale (ranging from 1 (Nothing) to 5 (A great deal)), to rank the teachers' level of self-efficacy. Tschannen-Moran and Hoy (2001) conducted first and second order factor analysis and confirmed the reliability and validity of the scale. The reliability coefficient (Cronbach Alpha) of the instrument was found to be 0.90. The Cronbach Alpha reliability value was yielded as 0.86 for instructional strategies, 0.86 for classroom management, and 0.81 for student engagement. Previously, the instrument was used by Mojavezi and Tamiz (2012) in their research investigating the relation of teacher self-efficacy with student motivation and achievement. Using Cronbach alpha, the reliability coefficient of the scale was 0.76. Thus, this instrument has been utilized in this study due to the reasonable acceptable index of reliability coefficient. The items were translated from English into Persian and Russian languages, and checked for their meaningfulness by the researchers. Initially, the questionnaire was taken to a pilot study in order to secure the researchers about the appropriate procedure and timing. Besides, piloy study helped the researchers to evade ambiguity and to observe other potential problems in the final study. An example of an item of "efficacy for instructional strategies" is "To what extend can you provide an alternative explanation or example when students are confused?" and an example of an item is "How much can you do to control disruptive behavior in the classroom?" from "efficacy for classroom management" component. An example item for "efficacy for student engagement" is "How much can you do to motivate students who show low interest in schoolwork?" Responses categories were evaluated with 5-point Likert scale following the original study of Tschannen-Moran and Hoy (2001). For the analyses the scale was reversed such that a high value represents a high level of self-efficacy.

Moreover, for obtaining data about the students' perceived learning motivation, a modified instrument namely "Student Learning Motivation for Science Questionnaire" (SLMSQ) was adopted. Items in the instrument were adapted from the study of Tuan, Chin and Shieh (2005). The original scale is composed of 35 items measuring six dimensions of "perceived self-efficacy, value for science learning, active learning strategies, achievement goal, performance goal, and learning environment stimulation". However, in this study due to the aim and scope the research, learning environment stimulation dimension was not included; thus, five dimensions consisting 29 items were utilized.

"Students' Achievement in Combined Science Education" (biology, chemistry, environmental science, physics, and sustainability classes) was evaluated by the average grades of the students obtained in the examinations in 2016-2018. The marks obtained range from 10% to 100% with a mean of 74%. In terms of gender, it was seen that the mean score of girls' was 76.89% (SD=.11) and boys' score was 81.36% (SD =.86). The grades were turned into interval scale as evaluated from 1 (1-29) to 5 (85-100) by the inclusion of combined science classes.

## DATA ANALYSIS AND RESULTS

In this study, the collected data were analyzed through inferential statistics, in which correlation analysis, regression analysis and t-test analysis were performed. Specifically, the statistical analysis revealed findings for the inquiry of the first two research hypotheses. Additionally, in this study, we tested two null hypotheses with the significance level at 0.05 margin of error. The findings of the study are displayed in tables and interpretations of the findings are discussed below.

Initially, for evaluating the data in order to observe the relations among the study variables, a Pearson product-moment correlation coefficient was computed. Thus, it was aimed to identify the direction and the strength of linear relationship between the teacher self-efficacy, student learning motivation and academic achievement. Cohen 's (1988) implications were referred for interpreting the strength of the relationships among the variables. Based on the reliability analysis, all scales revealed acceptable internal consistency of Cronbach's alphas between 0.86-0.93

**Table 1.** Reliability values of the variables

Variables	Number of items	$\alpha$
<b>Total teacher self-efficacy scale</b>	<b>24</b>	<b>0.91</b>
Instructional strategies	8	0.93
Classroom management	8	0.88
Student engagement	8	0.91
<b>Total student learning motivation</b>	<b>29</b>	<b>0.89</b>
Self-efficacy	7	0.93
Active learning strategies	8	0.88
Science learning value	5	0.91
Performance goal	4	0.86
Achievement goal	5	0.89
<b>Total academic achievement</b>	<b>5</b>	<b>0.86</b>

**Table 2.** Means, standard deviations, and correlations among study variables

Variables	M	SD	1	2	3	4	5	6
<b>1. Total teacher selfeff.</b>	4.08	.58	1	.325**	.311**	.336**	.465*	<b>.523*</b>
2. Instructional str.	3.51	.53	.325*	1	.303**	.297**	.405**	.501**
3. Classroom mng.	3.81	.71	.311	.303**	1	.112**	.388**	.409**
4. Student engag.	3.95	.49	.336*	.297**	.112**	1	.225**	.344**
<b>5. Total lear. motivation</b>	3.85	.45	.465*	.328**	.156**	.204**	1	<b>.393**</b>
<b>6. Total acad. achievem.</b>	3.89	.51	.523*	.503**	.406**	.341**	.393**	1

Pearson Correlation \*Correlation is significant at the 0.05 level (2-tailed)./\*\*. Correlation is significant at the 0.01 level (2-tailed).

**Table 3.** Model summary of regression analysis

Model	R	R Square	Adjusted R Square	Std. Error of the Estimate
Acad. achievement	.677	.591	.622	.47332

Predictors: (Constant), Instructional strategies, Classroom management, Student engagement

**Table 4.** Regression analysis of student learning motivation

Model		Sum of Squares	df	Mean Square	F	Sig.
Acad. achievement	Regression	74.621	240	4.995	44.226	.001 (a)
	Residual	47.205	550	.232		
	Total	121.826	790			

a. Predictors: (Constant), Instructional strategies, Classroom management, Student engagement

b. Dependent Variable 1: Student academic achievement

(Table 1). Table 2 presents descriptive statistics (means and standard deviations), and intercorrelations among teacher self-efficacy, learning motivation and academic achievement.

According to Table 2, there is a moderate significant, positive and linear relationship between teacher self-efficacy and students' academic achievement ( $r=.523, p<0.05$ ). Table 1 also reveals that there is a moderate, significant, and positive relation of each dimensions of teacher self-efficacy with both students' academic achievement. Instructional strategies dimension of teacher self-efficacy showed the highest correlation when analyzed with academic achievement [academic achievement ( $r=0.501, p<0.01$ )]. The correlations show that either form of teacher self-efficacy are likely to increase students' academic achievement of science classes.

### Test of Hypotheses: The Impacts of Teacher Self-Efficacy and Learning Motivation on Academic Achievement

Multiple regression analysis was conducted in order to test the main hypotheses of the study. The results reported that there were significant positive impacts of perceived teacher self-efficacy and learning motivation of students on academic achievement. Additionally, each dimensions of teacher self-efficacy had significant positive impacts on academic achievement. Table 3 presents the ANOVA results on the overall model and the findings show significance for teacher self-efficacy ( $F= 41.534, p<0.05$ ) and learning motivation ( $F= 44.226, p<0.05$ ) (Table 4 and Table 5).

**Table 5.** Summary results of coefficients of regression analysis

Dependent Variable: Student academic achievement			
Independent Variables	Beta	t Value	P Value
Constant		1.726	0.020
Instructional strategies	0.543	3.715	0.000
Classroom management	0.515	2.191	0.000
Student engagement	0.365	4.246	0.000
R=0.691; R <sup>2</sup> =0.614; F Value=41.534; p<0.05			
Dependent Variable: Student academic achievement			
Independent Variable	Beta	t Value	P Value
Constant		1.678	0.020
Learning motivation	0.509	3.555	0.000
R=0.677; R <sup>2</sup> =0.591; F Value=44.226; p<0.05			

**Table 6.** T-test results of students' academic achievement according to gender and national background

		N	Mean	Std. Deviation	Std. Error Mean	t	p
Academic achievement	Female	343	3.6	16.11	.05622	-1.35	0.02*
	Male	447	4.07	16.86	.04725		
Academic achievement	Iran	475	3.77		.04116	2.952	.004*
	Russia	315	4.11		.06241		

\*p < 0.05, \*\*p < 0.01

The overall R<sup>2</sup> is .614 suggesting that instructional strategies, classroom management, student engagement dimension of teacher self-efficacy combine to explain approximately 61% of the variance in academic achievement of science among students. Besides, 59% (R<sup>2</sup>=.591) of the variance in academic achievement of students was explained by learning motivation for science. These figures may seem high and explains how the variance of teacher self-efficacy and learning motivation in academic achievement measured on students can be very important. Hypothesis 1 stated that teacher's self-efficacy has a positive impact on students' academic achievement in science education. The results showed that teacher self-efficacy statistically significantly impacts student's learning motivation in science ( $\beta = 0.474$ ,  $t = 3.726$ ,  $p < 0.05$ ) suggesting hypothesis 1 is supported. Hypothesis 2 stated that students' motivation for learning science has a positive impact on students' academic achievement in science education and this construct also showed statistical significance ( $\beta = 0.509$ ,  $t = 3.555$ ,  $p < 0.05$ ) supporting Hypothesis 2. In addition, according to the beta coefficients and p-values, each of the dimensions of teacher self-efficacy contributed to academic achievement significantly (Instructional strategies:  $\beta = 0.543$ ,  $t = 3.715$ ,  $p < 0.05$ ; Classroom management:  $\beta = 0.515$ ,  $t = 2.191$ ,  $p < 0.05$ ; Student engagement:  $\beta = 0.365$ ,  $t = 4.246$ ,  $p < 0.05$ ).

Furthermore, H01 proposed that there is no significant difference in the academic achievement of male and female students in science education and H02 proposed that there is no significant difference in the academic achievement of students in science education in terms of their national background. The results of the above hypotheses (H01 and H02) are presented in **Table 6**.

To test whether academic achievement significantly differentiates based on gender and national background, t-test analysis was conducted. As shown in **Table 6**, there is no significant gender difference in achievement in science classes between the two groups (t-value = -1.35,  $p = 0.02$ ). However, as shown in **Table 6**, the level academic achievement is different for Iranian students and Russian students. Russian students have higher achievement level ( $t=2.952$  ( $\mu_{\text{Iranian}}=3.77$ ;  $\mu_{\text{Russian}}=4.11$ )) when compared to Iranian students. Based on the reported results, H01 is accepted and H02 is rejected.

## DISCUSSION, SUGGESTION AND CONCLUSION

In the 21st century, due to the societal needs and demands, there has been an increasing importance of science and technology advancements, which lead to the realization of science learning. This study has been constituted on the endorsement of the importance of science and technology for the national growth and economic development as well as the societal development of the societies within a continuous globalizing world. The literature also specified the relevance of science education and science learning in individual and societal outcomes by emphasizing that science learning at schools reshape the mental abilities of students towards academic performance and the improvement of the desired competencies, such as cognitive and scientific skills (Llbaó et al., 2016; Kola, 2013; Bautista, 2012; Lavigne, Vallerand, & Miquelon, 2007). Fundamentally, the strength of the societies and improvement in science and technology are suggested to be dependent on the young generation's attributes and commitment to scientific learning. Specifically, the crucial role of school education for science learning should be taken to account, including the interference of teachers, school management, students' achievement goals, etc. As



such, in this study, we highlighted the relevance of teachers' self-efficacy and students' learning motivation for science on students' achievement in science branches at secondary and high school organizations. In the literature, it has been indicated that teachers' self-efficacy help to increase the quality of science education, to develop critical and creative thinking of the students, to encourage the students to understand and participate in science classes. Hence, academic performance of the students in science can be accepted as a result of both teachers' self-efficacy and encouragement and the students' learning motivation. A number of studies also argued the roles of teachers' self efficacy and students' interest and learning motivation in their accomplishment of science related tasks and academic pursuits (e.g., Llbaio et al., 2016; Barnby, Kind, & Jones, 2008; Jegede, 2007; Osborne & Collins, 2001). Therefore, science learning is to engage students in a meaningful learning condition that constantly make them wander in a sustained implementations and practice (Osborne & Collins, 2001), and all these are influenced by the attitudes of classroom teachers and student's own learning motivation. Science education, in this sense, is suggested to be relevant with the societal impact of science; students' motivation and interests towards science learning; and the teachers' self-efficacy who are teaching science classes. In the studies of Holbrook, Rannikmae, Yager, and DeVreese (2003) and Llbaio et al. (2016), the role of societal background and students' learning motivation on the academic achievement in science among students have been addressed. Further, several research indicated the influence of teacher self-efficacy on academic achievement in science. Ronfeldt, Loeb and Wyckoff (2011) addressed the negative impact of teachers' low self-efficacy on student achievement. A recent study (Huber, Fruth, Avila-John, & López-Ramírez, 2016) examined the relationship between teacher's self-efficacy and student performance through a reciprocal relationship perspective and confirmed that teachers' self-efficacy had positive impacts on positive student outcomes. As provided in the literature part of the study, the previous conceptual knowledge and empirical evidences have shed light on the suggestions of this study. However, as part of the exemption of this study, first, both teacher self-efficacy and learning motivation were examined as the predictors of academic achievement in science among students in secondary/high schools in Iran and Russia, second, comparative analysis were performed in order to observe the societal impact on academic achievement in science education. Besides, the outcome of academic achievement in science also evaluated in terms of gender difference for both societies.

The findings of this study showed that there is a statistically significant relationship between teacher self-efficacy and student academic achievement in science. The result of the first hypothesis, which proposed the impact of teacher self-efficacy on academic achievement of secondary and high school students in science was found to be significant. A moderate significant, positive relationship between teacher self-efficacy and students' academic achievement ( $r=.523$ ,  $p<0.05$ ) was found and further, it was revealed that each dimensions of teacher self-efficacy (instructional strategies, classroom management and student engagement) were significantly and positively related to students' academic achievement. Since the positive correlations between teacher self-efficacy and student achievement have been demonstrated by a number of studies in the extant literature, the current findings are consistent with the previous studies (Bietenbeck, 2011; Cardenas & Cerado, 2016; Gavora, 2010; Henson, 2001; Mojavezi & Tamiz, 2012; Porter & Brophy, 2008; Rink, 2013; Rivkin et al., 2005; Wayne & Youngs, 2003). Thereby, it is confirmed that either form of teacher self-efficacy increase students' academic achievement of science classes. On the other side, the findings of this study determined that learning motivation of students in science as measured with their perceptions of self-efficacy regarding science classes, active learning strategies, value given to science learning, performance goals and achievement goals had significant impact on academic achievement in school science. Along with the suggestions of Poledřnová et al. (2014) and the implications of social-psychological perspective, the interactions of one's social relationships, self-evaluations and motivation reveals how his/her achievement orientation is shaped. Moreover, since motivation refers to reasons that underlie behavior that is characterized by the students' interests, willingness, and volition (Beal & Stevens, 2011), the impact of motivation in science learning is accrued to be the factor that adds to their achievements in school science. Thus, the finding of this study is also consistent with the background theories and other studies that addressed the influence of learning motivation of science classes on students' academic achievement in science (Tella, 2007; Bullock & Muschamp, 2006; Tuan et al., 2005; Reynolds & Walberg, 1992; Napier & Riley, 1985; Uguroglu & Walberg, 1979).

Moreover, comparative analysis has been done for observing whether there is a difference in the academic achievement of the students in terms of the gender and national background factors. The findings showed that academic achievement in science levels of secondary and high school students did not differ with respect to gender. This finding is in disagreement with Tella's (2007) findings that Nigerian secondary school students of males and females rated differently in academic achievement. The variation in the present result on this study is connected with the issue of societal environment as also addressed by Llbaio et al. (2016). Besides, the result of the hypothesis regarding national background showed that secondary/high school students differed significantly in their academic achievement based on the society they live in. While the present study was conducted in Iran and Russia; previous studies were conducted mostly in Asian or European countries, thus, this finding may contribute to the literature by providing knowledge about cultural factors. The results revealed that Russian students were high in academic achievement in science when compared to Iranian students. Indeed, societal factors may have roles in learning motivation and achievement in science, but further studies should be performed in order to obtain more

accurate results regarding societal effects. Furthermore, one thing that should be clear is the fact that achievement in science subject or academic generally depends on many motivating factors. The issue of gender or national background are only part of it likewise teacher support, school climate, parental involvement/support and or peer influence. All these should not be underrated because they are factors that can impact student achievement in science positively or negatively.

Consequently, when the teacher self-efficacy is high among teachers in science classrooms, the students display good attitude, better motivation and achievement in science. It is concluded that good impartation of science knowledge on the part of the teacher self-efficacy; along with student's interest and motivation in the subject and the display of positive attitude as earlier pointed out, are influential factors which when combine together are suggested to lead to better academic achievement in science education in secondary and high schools. We posit that the findings of this study will provide the basis for future research on this topic of growing scholarly and practical importance.

As for limitations of the study, there are some constraints of the study regarding the sample size and the focus area of the research. The research has been conducted in Iranian and Russian contexts with the participation of 790 students and 350 teachers drawn from 15 schools in two countries. It is suggested that future studies investigating the relevant topic should be performed within a larger sample groups and various schools including public and private educational institutions with all levels in order to better generalize the findings.

### ACKNOWLEDGEMENT

1. The authors appreciate the support of the Iranian and Russian respondents in filling out the questionnaires and accomplishing this study.
2. The work is performed according to the Russian Government Program of Competitive Growth of Kazan Federal University.
3. The publication has been prepared with the support of the "RUDN University Program 5-100".

### REFERENCES

- Abbasi, S., Moeini, M., Shahriari, M., Ebrahimi, M., Khoozani, E. K. (2018). Designing and manufacturing of educational multimedia software for preventing coronary artery disease and its effects on modifying the risk factors in patients with coronary artery disease. *Electronic Journal of General Medicine*, 15(3), em22. <https://doi.org/10.29333/ejgm/85942>
- Ale, S. O. (1989). School mathematics in the 1990's some major problems for developing countries. *International Journal of Mathematical Education in Science and Technology*, 20(5), 1-15. <https://doi.org/10.1080/0020739890200502>
- Alvares-Nunez, T. M. (2012). *Teacher self-efficacy: a link to student achievement in english language and mathematics in Belizean primary schools* (Unpublished Doctorate Dissertation). Oklahoma: Oklahoma State University.
- Anderson, R., Greene, M., & Loewen, P. (1988). Relationships among teachers' and students' thinking skills, sense of efficacy, and student achievement. *Alberta Journal of Educational Research*, 34(2), 148-165.
- Armstrong, P. (2009). The impact of teacher characteristics on student performance: An analysis using hierarchical linear modelling. *Stellenbosch Economic Working Papers: 25/14, A working paper of the department of economics and the bureau for economic research at the university of Stellenbosch*. Stellenbosch: University of Stellenbosch.
- Atkinson, J. W. (1964). *An introduction to motivation*. Princeton, Princeton University.
- Ball, J. (2010). *An analysis of teacher self-efficacy, teacher trust, and collective efficacy in a Southwest Texas School District* (Unpublished Doctorate Dissertation). U.S.A.: Texas A&M University.
- Bandura, A. (1997). *Self-efficacy: The exercise of control*. New York: W. H. Freeman and Company.
- Barmby, P., Kind, P., & Jones, K. (2008). Examining changing attitudes in secondary school science. *International journal of science education*, 30(8), 1075-1093. <https://doi.org/10.1080/09500690701344966>
- Bautista, R. G. (2012). The Convergence of Mayer's Model and Constructivist Model towards Problem Solving in Physics. *Journal of Education and Practice*, 3(10), 33-41.
- Beal, C. R., & Stevens, R. H. (2011). Improving students' problem solving in a web-based chemistry simulation through embedded metacognitive messages. *Technology, Instrumentation, Cognition and Learning*, 8(3), 255-271.
- Bietenbeck, J. C. (2011). *Teaching practices and student achievement: evidence from TIMSS* (Unpublished Master Thesis). Madrid: Economics and Finance at the Centro de Estudios Monetarios Financieros.
- Bigge, M. L. & Hunt, M. P. (1980). *Psychological foundations of education*. New York: Harper & Row Publishers.

- Brouwers, A., & Tomic, W. (2003). A test of the factorial validity of the Teacher Efficacy Scale. *Research in Education*, 69, 67-80. <https://doi.org/10.7227/RIE.69.6>
- Bullock, K., & Muschamp, Y. (2006) Learning about learning in the primary School. *Cambridge Journal of Education*, 36(1), 49-62. <https://doi.org/10.1080/03057640500491112>
- Cardenas, H. J., & Cerado, E. C. (2016). School Climate, Teachers' Efficiency and Learning Outcomes in Koronadal City Schools Division, Philippines. *Journal of Modern Education Review*, 6(1), 19-25. [https://doi.org/10.15341/jmer\(2155-7993\)/01.06.2016/003](https://doi.org/10.15341/jmer(2155-7993)/01.06.2016/003)
- Caroli, de M. E., & Sagone, E. (2014). Generalized self-efficacy and well-being in adolescents with high vs. low scholastic self-efficacy. *Procedia-Social and Behavioral Sciences*, 141, 867-874. <https://doi.org/10.1016/j.sbspro.2014.05.152>
- Chemers, M. M., Hu, L. T., & Garcia, B. F. (2001). Academic self-efficacy and first year college student performance and adjustment. *Journal of Educational Psychology*, 93(1), 55-73. <https://doi.org/10.1037/0022-0663.93.1.55>
- Clotfelter, C. T., Helen F. L. & Jacob L. V. (2007). How and Why Do Teacher Credentials Matter for Student Achievement?" CALDER Working Paper 2. Washington: The Urban Institute. <https://doi.org/10.3386/w12828>
- Cohen, J. (1988). *Statistical Power Analysis for the Behavioral Sciences*. Hillsdale: LEA.
- DeWitz, S. J., Woolsey, M. L., & Walsh, W. B. (2009). College student retention: An exploration of the relationship between self-efficacy beliefs and purpose in life among college students. *Journal of College Student Development*, 50(1), 19-34. <https://doi.org/10.1353/csd.0.0049>
- Ehrenberg, R. G., Brewer, D. J., Gamoran, A., & Willms, D. J. (2001). Class size and student achievement. *Psychological Science in the Public Interest*, 2(1), 1-30. <https://doi.org/10.1111/1529-1006.003>
- Ehrenberg, M. F., Cox, D. N., & Koopman, R. F. (1991). The relationship between self-efficacy and depression in adolescents. *Adolescence*, 26(102), 361-382.
- Elliot, A. J., & McGregor, H. A. (2001). A 2 × 2 achievement goal framework. *Journal of Personality and Social Psychology*, 80(3), 501-521. <https://doi.org/10.1037/0022-3514.80.3.501>
- Gavora, P. (2010). Slovak pre-service teacher self-efficacy: theoretical and research considerations. *The New Educational Review*, 21(2) 17-30.
- Ghaderi, A., & Salehi, M. (2011). A study of the level of self-efficacy, depression and anxiety between accounting and management students: Iranian evidence. *World Applied Science*, 12(9), 1299-306.
- Gusthart, J., & Springings, E. (1989). Student learning as a measure of teaching effectiveness. *Journal of Teaching in Physical Education*, 8, 298-311. <https://doi.org/10.1123/jtpe.8.4.298>
- Hackett, G. (1995). *Self-efficacy and career choice and development*. Cambridge: Cambridge University Press.
- Harris, D. N., & Sass, T. R. (2008). *Teacher Training, Teacher Quality and Student Achievement*. Washington: Center for the Analysis of Longitudinal Data in Education Research.
- Henson, R. K. (2001). The effects of participation in teacher research on teacher efficacy. *Teaching and Teacher Education*, 17, 819-836. [https://doi.org/10.1016/S0742-051X\(01\)00033-6](https://doi.org/10.1016/S0742-051X(01)00033-6)
- Holbrook, J., Rannikmae, M., Yager, R., & DeVreese, P. (2003). *Increasing the relevance of science education*. Paper presented at The NARST 2003 Annual International Conference. Philadelphia, USA.
- Huber, M., Fruth, J. D., Avila-John, A., & Ramirez, E. (2016). Teacher self-efficacy and student outcomes: A transactional approach to prevention. *Journal of Education and Human Development*, 5(1), 46-54. <https://doi.org/10.15640/jehd.v5n1a5>
- Jegade, S. A. (2007). Students' anxiety towards the learning of chemistry in some Nigerian secondary schools. *Educational Research and Review*, 2(7), 193-197.
- Jex, S. M., & Dudanowski, D. M. (1992). Efficacy beliefs and work stress: an exploratory study. *Journal of Organizational Behavior*, 13, 262-279. <https://doi.org/10.1002/job.4030130506>
- Kirilova, E. A., Kurbanov, R. A., Svechnikova, N. V., Zul'fugarzade, T. E., & Zenin, S. S. (2017). Problems of Fighting Crimes on the Internet. *Journal of Advanced Research in Law and Economics*, 8(3), 849-856.
- Kola, A. J. (2015). Importance of science education to national development and problems militating against its development. *American Journal of Educational Research*, 1(7), 225-229. <https://doi.org/10.12691/education-1-7-2>
- Kwon, H. (2016). Effect of Middle School Students' Motivation to Learn Technology on Their Attitudes toward Engineering. *Eurasia Journal of Mathematics, Science and Technology Education*, 12(9), 2281-2294. <https://doi.org/10.12973/eurasia.2016.1279a>

- Lavigne, G. L., Vallerand, R. J., & Miquelon, P. (2007). A motivational model of persistence in science and education: A self-determination theory approach. *European Journal of Psychology of Education, 22*, 351-369. <https://doi.org/10.1007/BF03173432>
- Le, H., Casillas, A., Robbins, S. B., & Langley, R. (2005). Motivational and skills, social, and self-management predictors of college outcomes: Constructing the Student Readiness Inventory. *Educational and Psychological Measurement, 65*(3), 482-508. <https://doi.org/10.1177/0013164404272493>
- Llbao, N., Sagun, J., Tamangan, E., Pattalitan, A., Dupa, M., & Bautista, R. (2016). Science learning motivation as correlate of students' academic performances. *Journal of Technology and Science Education, 6*(3), 209-218. <https://doi.org/10.3926/jotse.231>
- Maslow, A. H. (1955). *Motivation and Personality*. New York: Harper and Row.
- Mazumder, Q. (2014). Student Motivation and Learning Strategies of Students from USA, China and Bangladesh. *International Journal of Evaluation and Research in Education, 3*(4), 205-210. <https://doi.org/10.11591/ijere.v3i4.6288>
- McClelland, D. (1995). Achievement motivation in relation to achievement-related recall. *Motivation and Emotion, 19*, 59-76. <https://doi.org/10.1007/BF02260672>
- Midgley, C., Feldlaufer, H., & Eccles, J. S. (1989). Student/teacher relations and attitudes towards mathematics before and after the transition to junior high school. *Child Development, 90*, 981-992. <https://doi.org/10.2307/1131038>
- Mojavezi, A., & Tamiz, M. P. (2012). The Impact of teacher self-efficacy on the students' motivation and achievement. *Theory and Practice in Language Studies, 2*(3), 483-491. <https://doi.org/10.4304/tpls.2.3.483-491>
- Moore, W., & Esselman, M. (1992). *Teacher efficacy, empowerment, and a focused instructional climate: Does student achievement benefit?* San Francisco: Paper presented at the annual meeting of the American Educational Research Association.
- Murray, H. A. (1938) *Explorations in personality*. New York: Oxford University Press.
- Napier, J. D., & Riley, J. P. (1985). Relationship between affective determinants and achievement in science for seventeen-year-olds. *Journal of Research in Science Teaching, 22*(4), 365-383. <https://doi.org/10.1002/tea.3660220407>
- Nielsen, K., Yarker, J., Randall, R., & Munir, F. (2009). The mediating effects of team and self-efficacy on the relationship between transformational leadership, and job satisfaction and psychological well-being in healthcare professionals: A cross-sectional questionnaire survey. *International Journal of Nursing Studies, 46*, 1236-1244. <https://doi.org/10.1016/j.ijnurstu.2009.03.001>
- Noar, S. M., Anderman, E. M., Zimmerman, R. S., & Cupp, P. K. (2005). Fostering achievement motivation in health education: Are we applying relevant theory to school-based HIV prevention programs?. *Journal of Psychology & Human Sexuality, 16*(4), 59-76. [https://doi.org/10.1300/J056v16n04\\_04](https://doi.org/10.1300/J056v16n04_04)
- O'Leary, A. (1992). Self-efficacy and health: behavioural and stress-physiological mediation. *Cognitive Therapy and Research, 16*, 229-245. <https://doi.org/10.1007/BF01173490>
- Ochonogor, C. E. (2011). Performance Analysis of Science Education Undergraduates: A Case Study of Biology Education Students. *US-China Education Review, 5*, 682-690.
- Odogwu, H. N. (1994). Primary Secondary Teachers and the Teaching of time Concept in Schools. *Education Today, 7*(2), 1-19.
- Ohuche, R. O. (1978). Recent Attempts at Mathematics curriculum renewal in English Speaking West Africa. *Abacus, 12*(1), 35-48.
- Osborne, J. F., & Collins, S. (2001). Pupils' views of the role and value of the science curriculum: a focus-group study. *International Journal of Science Education, 23*(5), 441- 468. <https://doi.org/10.1080/09500690010006518>
- Pajares, F. (1996). Self-efficacy beliefs in achievement settings. *Review of Educational Research, 66*, 543-578. <https://doi.org/10.3102/00346543066004543>
- Pajares, F., & Valiante, G. (1999). Grade level and gender differences in the writing selfbeliefs of middle school students. *Contemporary Educational Psychology, 24*, 390-405. <https://doi.org/10.1006/ceps.1998.0995>
- Pintrich, P. R., & Schunk, D. H. (1996). *Motivation in education: Theory, research, and applications*. Englewood Cliffs: Prentice Hall Merrill.
- Poledňová, I., Stranska, Z., & Niedobová, H. (2014). Achievement motivation of secondary school students in relation to their social position in the class. *Problems of Psychology in the 21st Century, 8*(1), 61-70.
- Porter, A. C., & Brophy, J. E. (1988). Synthesis of research on good teaching: Insights from the work of the institute for research on teaching. *Educational Leadership, 45*(8), 74-85.



- Rus, C.M., Radu, L.E., Vanvu, G.I. (2016). Motivation for Participating to Sports Competitions in School. *Revista de Cercetare si Interoventie Sociala*, 52, 195-203.
- Reynolds, A. J., & Walberg, H. J. (1992). A structural model of science achievement and attitude: An extension to high school. *Journal of Educational Psychology*, 84(3), 371-382. <https://doi.org/10.1037/0022-0663.84.3.371>
- Rink, J. E. (2013). Measuring teacher effectiveness in physical education. *Research Quarterly for Exercise and Sport*, 84, 407-418. <https://doi.org/10.1080/02701367.2013.844018>
- Rivkin, S. G., Hanushek, E. A., Kain, J. F. (2005). Teachers, schools, and academic achievement. *Econometrica*, 73(2), 417-458. <https://doi.org/10.1111/j.1468-0262.2005.00584.x>
- Rockstroh, A. H. (2013). *Teacher Characteristics on Student Achievement: An Examination of High Schools in Ohio* (Unpublished Master Thesis). Kansas City: Martin School of Public Policy and Administration.
- Ronfeldt, M., Loeb, S., & Wyckoff, J. (2013). How teacher turnover harms student achievement. *American Educational Research Journal*, 50(1), 4-36. <https://doi.org/10.3102/0002831212463813>
- Ross, J. A. (1992). Beliefs that make a difference: The origins and impacts of teacher efficacy. *Paper presented at the Annual Meeting of the Canadian Association for Curriculum Studies*. Canada.
- Ross, J. A., & Bruce, C. (2007). Self-assessment and professional growth: The case of a grade 8 mathematics teacher. *Teaching and Teacher Education*, 23(2), 146-159. <https://doi.org/10.1016/j.tate.2006.04.035>
- Rotter, J. (1966). Generalized expectancies for internal versus external control of reinforcement. *Psychological Monographs*, 80(1), 1-28. <https://doi.org/10.1037/h0092976>
- Ruby, A. M. (2001). Hands-on science and student achievement. Retrieved from [http://www.rand.org/pubs/rgs\\_dissertations/RGSD159.html](http://www.rand.org/pubs/rgs_dissertations/RGSD159.html).
- Say, S., Bag, H. (2017). The Evaluation of the Effect of a Newly Designed Computer Game on 7th Grade Students' Motivation towards Science and Aggression. *Eurasia Journal of Mathematics, Science and Technology Education*, 13(8), 5379-5393. <https://doi.org/10.12973/eurasia.2017.00831a>
- Schunk, S., & Pajares, F. (2001). *Development of achievement motivation*. San Diego: Academic Press.
- Shcherbakov, V. S., Ashmarina, S. I., Suraeva, M. O., Kurbanov, R. A., Belyalova, A. M., Gurbanov, R. A., & Torkunova, J. V. (2017). Iteration as a Regulatory Function of Education Management. *Eurasian Journal of Analytical Chemistry*, 12(7), 1211-1219. <https://doi.org/10.12973/ejac.2017.00246a>
- Singh, K. (2011). Study of Achievement Motivation in Relation to Academic Achievement of Students. *International Journal of Educational Planning & Administration*, 1(2), 161-171.
- Spence, J. T., & Helmreich, R. L. (1983). Achievement-related motives and behaviors. In J. T. Spence (Ed.), *Achievement and achievement motives*. San Francisco, Calif: W. H. Freeman.
- Steinmayr, R., & Spinath, B. (2009). The importance of motivation as a predictor of school achievement. *Learning and Individual Differences*, 19(1), 80-90. <https://doi.org/10.1016/j.lindif.2008.05.004>
- Stetz, T. A., Stetz, M. C., & Bliese, P. A. (2006). The importance of self-efficacy in the moderating effects of social support on stressor-strain relationships. *Work & Stress*, 20, 49-59. <https://doi.org/10.1080/02678370600624039>
- Stipek, D., Givvin, K., Salmon, J., & MacGyvers, V. (1998). Can a teacher intervention improve classroom practices and student motivation in mathematics? *Journal of Experimental Education*, 66, 319-337. <https://doi.org/10.1080/00220979809601404>
- Tella, A. (2007). The Impact of Motivation on Student's Academic Achievement and Learning Outcomes in Mathematics among Secondary School Students in Nigeria. *Eurasia Journal of Mathematics, Science & Technology Education*, 3(2), 149-156. <https://doi.org/10.12973/ejmste/75390>
- Tschannen-Moran, M., & Hoy, A. W. (2001). Teacher efficacy: Capturing an elusive construct. *Teaching and Teacher Education*, 17, 783-805. [https://doi.org/10.1016/S0742-051X\(01\)00036-1](https://doi.org/10.1016/S0742-051X(01)00036-1)
- Tschannen-Moran, M., Woolfolk Hoy, A., & Hoy, W. K. (1998). Teacher efficacy: Its meaning and measure. *Review of Educational Research*, 68, 202-248. <https://doi.org/10.3102/00346543068002202>
- Tuan, H. L., Chin, C. C., & Tsai, C. C. (2005). Investigating the Effectiveness of Inquiry Instruction on the Motivation of Different Learning Styles Students. *Int J Sci Math Educ*, 3, 541-566. <https://doi.org/10.1007/s10763-004-6827-8>
- Uguroglu, M. E., & Walberg, H. J. (1979). Motivation and achievement: A quantitative analysis. *American Educational Research Journal*, 16(4), 375-389. <https://doi.org/10.3102/00028312016004375>
- Umoinyang, I. E. (1999). *Student socio-psychological factors as determinants of achievement in senior secondary mathematics* (Unpublished Doctorate Dissertation). Ibadan: University of Ibadan.

- Wang, T.S., Hsieh, S.W. (2015). An Assessment of Individual and Technological Factors for Computing Validation: Motivation and Social Processes. *Revista de Cercetare si Interventie Sociala*, 50, 156-171.
- Ward, E. A. (1997). Multidimensionality of Achievement Motivation among Employed Adults. *The Journal of Social Psychology*, 137(4), 542-544. <https://doi.org/10.1080/00224549709595476>
- Wayne, J., & Youngs, P. (2003). Teacher characteristics and student gains: A review. *Review of Educational Research*, 73(1), 89-122. <https://doi.org/10.3102/00346543073001089>
- Wentzel, K. R. (1998). Social Relationship and Motivation in middle School. The Role of Parents, Teachers and Peers. *British Journal of Education Psychology*, 68(2) 35-43. <https://doi.org/10.1037/0022-0663.90.2.202>
- Zellars, K. L., Hochwarter, W. A., Perrewe, P. L., Miles, A. K., & Kiewitz, C. (2001). Beyond self-efficacy: interactive effects of role conflict and perceived collective efficacy. *Journal Of Managerial Issues*, 13, 483-499.
- Zenzen, T. G. (2002). *Achievement motivation* (Unpublished Master Dissertation). U.S.A.: University of Winconston-stont Menomonie.
- Zimmerman, B. J. (1995). Self-efficacy and educational development. In A. Bandura (Ed.), *Self-efficacy in changing societies* (pp. 202-231). New York: Cambridge University Press. <https://doi.org/10.1017/CBO9780511527692.009>

**<http://www.ejmste.com>**



## STEM Education in English of Early Childhood in China

Wenxiao Zhao <sup>1\*</sup>

<sup>1</sup> School of Foreign Languages, University of Jinan, Jinan, Shandong, CHINA

Received 29 October 2017 • Revised 16 March 2018 • Accepted 28 March 2018

### ABSTRACT

Changes in curricula, publication policy and information technology, notably in China have led to concentrations in the role of STEM (science, technology, engineering and mathematics) education in early childhood and applauded to proliferations of imported up-to-date reading materials and mobile apps in English. This paper proposes a longitude study of a Chinese toddler learning STEM by reading picture books and playing with tablet and suggests new horizons in parenting and in STEM education during children's early years. The present study was carried out from 2016, when the participant reached one year old, eligible to learn to speak and to concentrate on the picture books read by parents who had filled a language background questionnaire with information on themselves and the participant. Tablet playing brought about for the two-year-old toddler and collections of STEM books in English was added for the second year. Data collection lasted for two years with an iLab video camera, capturing utterances and motions for five minutes per week transcribed by VoiceScript software. Tests were given quarterly at private home by tapping in mobile app "Bilingual Child Learning" which consists of 20 basic STEM themes before scores were collected. Findings indicate that (1) it is accessible for children of very early years to be engaged in English STEM resources, (2) kids' limited English dominance does not impede learning STEM, (3) and to think in English in early STEM contributes to children's English.

**Keywords:** STEM, early childhood education, English picture books, Chinese toddlers

### INTRODUCTION

STEM research has incited theoretical concern in modern educational research. Early childhood exposure to STEM initiatives is a growing fixture in China. China has experienced a rapid current of change in its present academic curricula, its publication policy and information technology. These trends have led to a mass integration of science, technology, engineering, and mathematics (STEM). This research will explore a longitudinal study of STEM learning systems for toddlers. This toddler-oriented system incorporates picture books and tablet games. This study was conducted in 2016, when participants reached one year of age. This child met criteria for speaking ability and capacity to focus on their attention on the pictures books. In the second year, STEM books tablets were added to the curriculum.

STEM education has dire implications in society, given the present economic trends. Mathematical and scientific skills render children competitive in the future economic climate (Langdon et al., 2011). The future implications of these skills are salient given the current shifts in the professional realms. Professions centered on mathematics and science are growing in prominence, supplanting more traditional fields (Breiner, Harkness, Johnson, & Koehler, 2012). In fact, occupations in these fields are exceeding the growth of non-STEM oriented industries. The persistent growth of the global economy will ultimately hinge on those in these fields in question (Land, 2013). Furthermore, in the future they may stabilize the economy and cater to its continued success. Hence, the STEM emphasis of this study's methods is imperative. These skills, when instilled at early ages, project future economic growth. The key is to inculcate these skills in early ages during impressionable developmental phases. This field of education is responsible for cultivating a host of critical skills (Stohlmann, Moore, & Roehrig, 2012). It improves scientific

### Contribution of this paper to the literature

- This study determined that early age toddlers were capable of assimilating STEM knowledge. Children demonstrate conceptual faculties which enable this process, and assure the transfer of STEM knowledge.
- This study also confirmed the ease of transmission this knowledge, in spite of linguistic barriers. Early childhood toddlers were capable of making complex conceptual connections.
- This study examined quantitative reasoning. Using a visual appeal, the confederate in the study reinforced quantitative knowledge in the subject.

capacity and critical thinking (Stohlmann et al., 2012). This also offers potential applications in nations where STEM skills are notably lacking.

The advent of technology has pervaded every realm of human life, and is re-defining professions. Furthermore, it is redefining education itself (Al Musawi, 2011). These professions must integrate increasing awareness of technical skills to support the future. Engineering, an especially nuanced industry, however, addresses challenges relevant to the changing environment (Leveson, 2011). Finally, mathematics pervades a multitude of studies in modern society. Furthermore, the landscape of education is transitioning to envelop all learners as proactive members of the learning process (Chen & Tseng, 2012). This increasing engagement, and relative accessibility of learning tools and devices, may facilitate the transfer STEM knowledge. The preparation of longitudinal growth in these areas can commence at early stages.

Findings support the conceptual idea that developmental views support early learning in children. Early opportunities and exposure to STEM will cultivate a desire and passion for those subjects. Developmental studies reveal neurogenesis occurs in the early stages of life. 7500 synaptic connections exist in the brain during birth (Mundkur, 2005). However, in a period of 2 years, these neuron levels increase rapidly (Mundkur, 2005). Hence the stage between infancy and 2-years of age is optimal for reinforcing STEM concepts. Neuroplasticity is far more vulnerable in the childhood mind. This refers to the physiological and structural changes in the brain as new synaptic connections form. These connections are formed in response to the reinforcement of skills (Mundkur, 2005). However, neurogenesis is also a normal process. Adaptive plasticity occurs in the childhood brain and respond to specialization of skills. This process is expected to occur and support the implementation of the STEM curriculum.

The problem statement for this study is as follows. This study seeks to explore the effect of STEM-related learning resources on infant/toddler aged children. It seeks to uncover which methods are conducive to quantitative learning in early stages and how those devices are employed to facilitate these outcomes. This study will incorporate the following hypothesis. Children, at early stages, may fully comprehend STEM concepts relative to their cognitive levels. It is also assumed that poor English proficiency will not impede STEM. Finally, students who think in English during STEM curriculums may amplify their English learning.

The following questions will be proposed in light of this study. How do picture books provide the critical precursors for high-order stem skills in children? Does second year STEM resources improve critical thinking in toddler aged children?

## LITERATURE REVIEW

A multitude of studies have explored the early implementation of STEM-related concepts in children. In a study, conducted in the journal of *Instructing Exceptional Children*, a preschool teacher examined a STEM curriculum. Christa, the teacher, partook in a mixed-ability learning settings (Aronin & Floyd, 2013). More specifically, she observed the impact of this method on a wide range of cognitive abilities, including children who suffered cognitive limitations. She centralized her focus on a four-student group, comprising students in the 4-year age range (Aronin & Floyd, 2013). One student suffered from a developmental disorder. She instructed the child on learning new skills on the iPad tablet (Aronin & Floyd, 2013). Each child awaited their turn as she instructed individuals on a new application. The iPad application was referred to as Monkey Math. Monkey Math is a STEM application tailored to children in early developmental stages (Aronin & Floyd, 2013).

Another teacher featured in this study (Ms. Lena) is using a different application for her children (Aronin & Floyd, 2013). She is instructing her students on engineering concepts with the aid of the BridgeBasher application. Student groups are devised to cultivate leadership and learning as well. Students show high levels of engagement in these classroom activities, hence the accessibility of STEM concepts (Aronin & Floyd, 2013). As this study conveys, there are many opportunities in preschool to cultivate STEM skills in early ages (Aronin & Floyd, 2013). A number of devices and avenues may be used to facilitate this transfer of knowledge. Preschoolers have a host of opportunities to partake in technology (Aronin & Floyd, 2013). This includes smart phones, computer labs, and education video games as well.

Some students, in light of learning these concepts, have suffered obstructions to their education process. Some technology is highly limited in terms of infusing concepts for preschool children (Aronin & Floyd, 2013). Hence, in the study discussed for this paper, it is crucial to utilize accessible methods and technology. According to this study, the most effective methods entails targeting the youngest students, as they are more susceptible to novel concepts (Aronin & Floyd, 2013). Hence, this vantage point justifies the study in discussion. Furthermore, results improve over long term stages, when technology is embedded in classroom settings. These designs are more effective when teachers and students partake in cooperative learning dynamics. The collective exchange of STEM knowledge is the best approach, as will be discussed (Aronin & Floyd, 2013). Curriculums such as these were devised to improve students learning and bolster the entry into STEM careers (Aronin & Floyd, 2013). This study teaches educators to optimize their use of available technology opportunities. Teachers should be wary of their interactions with children to preclude obstructions to STEM learning in childhood (Aronin & Floyd, 2013).

Finally, this study emphasizes a few crucial principles to ensure the proper instruction of STEM concept (Aronin & Floyd, 2013). First, the students should engage in the necessary action to ensure the anticipated outcomes. Students should be able to perceive the cause and effects of conceptual relationships by engaging in the necessary action and observing the ensuing outcomes (Aronin & Floyd, 2013). The action and response should occur swiftly to ensure the child is properly conditioned.

Early exposure to STEM education alters student perceptions of learning. Perceptions often dictate motivation to learn in student environments. While STEM opportunities exist for high school and middle school students, fewer efforts are made for younger generations (DeJarnette, 2012). Thus, STEM materials are especially lacking for toddlers and preschool aged children. Taking a proactive road to teaching STEM materials in earlier years forge true foundations for learning in high school (DeJarnette, 2012). Slowly but surely, these initiatives have grown in prominence in the United States. Country comparisons were conducted in regard to the effects of STEM education on youth. A number of challenges exist in nations such as Australia in regard to implementation (Marginson et al., 2013).

The universal design for learning (UDL) can facilitate the employment of STEM learning materials. Teachers who improve their assessment strategies will enhance student outcomes (Basham & Marino, 2013). Furthermore, efficacious instruction is also recommended to improve the STEM learning objectives (Basham & Marino, 2013). This field provides opportunities for disabled students also to partake in math and science professions (Basham & Marino, 2013).

STEM is also revealed to have experiential and creative potential as well. Some have petitioned adding the arts to the field to further integrated knowledge resources (Robelen, 2011). It may be applied to the construction of technical toys designed for middle school children. However, this study provides no insight regarding applications to preschool children however (Quang et al., 2015). The technological field has been successfully instructed in middle schools in Vietnam (Quang et al., 2015). Technical toys can be devised in order to cultivate student competencies. Over the years, a rise in technical studies still remains controversial in the realm of education. However, toys provide a practical model of teaching students in a modern educational environment (Quang et al., 2015). Using multidisciplinary perspectives, students can learn to apply these skills to the real world (Quang et al., 2015). This pertains to the study in question which uses materials and tablet devices as well to emphasize STEM-related concepts. Such materials, which will be tested in this study, may facilitate instilling these skills in early childhood. These aforementioned studies pertain to the study being performed in this research. First, this research will utilize the integrative methods required for STEM oriented instruction (Becker & Park, 2011). However, these findings will instead be adapted to serve the younger generation of preschool students. Perhaps, by beginning early, instructors can revise student perceptions of STEM knowledge.

A number of countries have grown to understand the economic value of STEM studies in school. These skills are absolutely imperative in the economic realm. Those who fail to embody these skills may fail to compete in the Turkish economy (Corlu, Capraro, & Capraro, 2014). Modern criticisms have emerged regarding to critical reforms occurring in school environments (Corlu, Capraro, & Capraro, 2014). Some contend teachers in this nation were neither equipped nor prepared to address these issues. Integrated teaching, however, can facilitate STEM instruction in school environments (Corlu, Capraro, & Capraro, 2014).

However, the proper environment is required to ensure the implementation of this curriculum. A study assessed preschool environments to gauge their suitability for science education and learning (Brenneman, 2011). The interest in preschool science is steadily increasing in the United States. Efforts have been made to bolster the science understanding and literacy in these environments as well (Brenneman, 2011). This serves as a prerequisite to future, more intricate numerical and scientific concepts (Brenneman, 2011). Notably, funding efforts in this area have increased in this area in order to support the employment of this model in the classroom. In spite of fundraising efforts, this has failed to yield a thorough integration of instructional methods. The issue is the implementation of STEM, which struggles to ensure lasting results in the United States (Brenneman, 2011). New tools must be introduced to better assess child learning in science, along with instruction techniques for learning.

- 
- \*MOM= mother
  - \*TOM= subject
  - &= incomplete or unintelligible phonological string
  - x= unintelligible word with an unclear phonetic shape
  - [/]= repetition
  - [//]= rephrasing (repetition of main idea with some changes)
  - [///]= full reformulation
  - +//.= self-interruption
  - @sp = Spanish phrase
  - @ch = Chinese phrase
  - ( ) = English translation of Chinese and Spanish phrases
  - %act = actions
- 

**Figure 1.** Transcription conventions

Learning and knowledge assessments, entail sustaining and evaluating scientific learning (Brenneman, 2011). This can be achieved with the aid of performance analyses. Furthermore, instruction should occur on an individualized basis for better results. To ensure the successful implementation of STEM concepts, it is crucial monitor progress as well (Brenneman, 2011). Science learning thus requires more quality measures.

Modern studies support the notion that STEM education should commence during early childhood. STEM jobs are becoming increasingly difficult to find and secure in the global economy (Chesloff, 2013). As noted, it is growing in competitiveness, hence the need for early childhood methods. This study, presented in this paper, proceeds along the notion of this issue, that early action yields sustainable results. When preschool children are exposed to these methods, they develop a host of skills to carry to the future. To deny these skills, in integrated settings, would create a significant economic drawback. Hence, this study should be viewed in longitudinal terms, rather than their immediate context in the study.

Additional studies have noted how assistive technology can reinforce STEM concepts in youth. Assistive technologies such as these were mimicked in the study in the form of a tablet device (Clabaugh, Ragusa, Sha, & Matarić, 2015). However, other studies have explored the realm of robotic technology to aid this potent educational climate. Socially Assistive Robot tutoring systems were observed in a STEM study (Clabaugh et al., 2015). It was determined this technology could inculcate favorable learning behaviors and patterns as well. Therefore technology is integral to instilling the desired behaviors conducive to scientific and numerical knowledge. Other studies have confirmed the overall effectiveness of touchscreen technology for preschool STEM learning knowledge (Aladé, Lauricella, Beaudoin-Ryan, & Wartella, 2016). Computer based scaffolding can also aid students as they strive to utilize STEM-oriented skills (Belland et al., 2017).

## METHODOLOGY AND DESIGN

The methodology of this study is presented as follows. The design will entail a longitudinal method of STEM instruction, via picture books and tablet technology. Data collection will ensue over a period of two years. The materials for this study encompassed an iLab video camera, recording motions and utterances five minutes per week. Responses were transcribed and recorded with the aid of VoiceScript software. Confederates performed tests at quarterly intervals in home environments by partaking in the mobile app. Bilingual Child Learning comprised a total of 20 STEM themes after which scores were obtained.

The study was first performed in 2016 when the participants reached one year old. They were capable of speaking and concentrating focus on the picture books employed. The parents fulfilled the language criteria by completing an assigned questionnaire, in which they recorded personal data. At one year of age, children were provided picture books to stimulate STEM conceptual learning. At age two, the toddlers were provided with a tablet and a compilation of STEM books. All books were accessible to children during early ages, and their English proficiency did not affect STEM comprehension.

This study implemented the following procedure. A coding mechanism was used to encode the subject responses (**Figure 1**). MOM signified mother, and TOM signified the subject of the study. The symbol “&” refers to incomplete or unintelligible phonological strings. The “x” symbol signifies unintelligible words with unclear phonetic shapes. [/] signifies repetition, [//] signifies rephrasing, [///] symbolizes full reformulation, +// symbolizes self-interruption, @sp, Spanish phrase, @ch, a Chinese phrase, ( ) = English translation of Chinese and Spanish phrases, %act signifies actions.

The study encompassed distinct concepts for each learning trial. The first context pertained to “Drawing with oval shaped bicolor crayons”. The duration was 5 minutes. This was labeled as Transcription 01 “colors”. The second context, which persisted for 4 minutes, was “In the kitchenette designed for children with plastic fruit and vegetables.” This was labeled as Transcription 02, Fruit and Vegetables. The third context resided “In the kitchen designed for children with plastic fruit and vegetables.” This was labeled Transcription 03 “Healthy Food”. The duration was 4 minutes long. Transcription 04, or “Counting Animals” entailed the following context “Playing with toy animals after lunch.” the duration was 4 minutes long. Transcription 05, or “Plus and Minus” incorporates the context “playing before sleep”. The duration of this study was 5 minutes long.

## RESULTS

The results of this study indicated the following results. The Transcription 01 results uncovered the following findings ([Appendix A](#)). In this trial, the child is asked to identify a color and correctly responds it is orange, in Chinese. The child was asked to pronounce the word in English as well, to which the child responded correctly. The mother responded with an interrogative remark, to inquire if the color is orange, which the child confirms. The child was asked if orange was the only color present in this context. He notes that green is present in Chinese. The mother responded and stated it was green in English, then awaited the physical action of the child. The child gestured to the green side. This implied the child comprehended “green” in English. The child then rephrased and repeated the term “green”. The mother then instructed the child to remember the color was phrased “green”. The child intimated understanding by nodding his head. The mother instructed the child to point to the blue and red crayon/ The child inquired which crayons met this criteria and the mother gestured to the correct color. The child then pointed the side, and used an interrogative marker for “blue” in Chinese. The mother asked the child to vocalize blue in English and to name the additional crayon in English, which was red. The child employed repetition and rephrasing to name the crayons “red” and “blue” in English. The child is presented an upside down dual colored crayon. The child was asked to point to the red side. The child inquired if a given side is yellow and gestured in that direction. The child gestured to the purple side of a crayon, and requested the name of this color. The mom responded the color was “purple” to which the child responded “bubble”. The child made a connection between purple and grape to distinguish it from bubble. This revealed conceptual and practical knowledge, relating an attribute to the real world. The child pointed to the pink side of the crayon and inquired if it was orange, incorrectly. The mother confirmed it was not orange. The child used repetition to inquire if the color was red, which was also incorrect. The mother revealed it was pink and requested the child ponder explaining the pink color. The mother conveyed the Chinese translation equated to powdered red. The child used an interrogative marker to confirm the pink color was in fact powdered red in Chinese. The child noted a particular visual was pink and black. The mother confirmed the visual was pink and black. The child employed repetition and re-affirmed these color names.

The results of Transcription 02 revealed the following findings ([Appendix A](#)). The instructor enabled the child to distinguish between fruit and vegetables. This was achieved through rephrasing on the part of the instructor. The child used interrogative reasoning to determine if apple and banana were fruit. The child was instructed to identify more fruit. These fruits included pear, grape, and peach. The aforementioned fruits were identified in English. However, the child struggled to identify papaya. The child was informed the unknown fruit was a papaya and instructed to point in its direction. The subject then identified papaya in Chinese by name. This child also vocalized water melon in Chinese. The child then inquired if watermelon is a fruit, to which the instructor responded yes. The instructor asked the child to identify an unknown vegetable. The child pointed in the direction of the potato. The child struggled to enunciate the word “potato”. An interrogative marker was used to distinguish the pronunciation between potato in English and Chinese, by the subject. When the child is asked is he/she likes potatoes, this is followed by silence. This implies a lack of understanding of the question. The child is asked if it is fruit or vegetable, and responds it is a vegetable.

The results of Transcription 03 revealed the following findings ([Appendix A](#)). The mother asked the subject to identify a healthy food, after which the child gestured toward an apple. The mother proceeded to inquire of another healthy food, after which the child gestured to a carrot. The mother revealed chocolate to assess the child’s differentiation between healthy and unhealthy food. The child responded with yes, followed by rephrasing with “no”. The mother confirmed this response, and associated “no” with the wiggle of the left index finger. The mother proceeded to permit a small piece of chocolate per day. After splitting a piece and passing it to Thomas, she reinforced the rule of unhealthy food. For further reinforcement, she inquired of the daily frequency child was permitted to consume chocolate. The child is asked if lollipops are healthy, to which the mother responds with no.

The results of Transcription 04 revealed the following findings ([Appendix A](#)). In this context, the child distinguished among one, two, and three and completed basic addition (one plus one). The child identified an imitation elephant by abridging its name to Eli. The mother requested the full name of the animal, to which the child responded “Elephant”. The mother placed three flashcards of elephants together and inquired how many



were present, presenting the problem what is “one plus two”. The child initially responded with two, showing limitations in quantitative reasoning (normal for this age). The mother requested the child count the present elephants to reinforce the mathematical equation, to which the child responded three. The mother proceeded to reinforce the numerical value of one plus two. The mother introduced the child to the next animal, which the child identified as a cat. She requested the child identify the number of cats by inquiring what is “two plus two”, placing four cards together. The child responded incorrectly with “three” after which they proceeded to count the individual cards. After reinforcement, the child answered four.

The results of Transcription 05 revealed the following findings (Appendix A). This trial uncovered the child’s quantitative reasoning. The child calculated one plus four correctly. The child also demonstrated the capacity for subtraction. The child demonstrated these qualities by gesturing toward books.

## CONCLUSION, DISCUSSION, AND RECOMMENDATIONS

The following findings were uncovered, as per the hypothesis. This study determined that early age toddlers were capable of assimilating STEM knowledge. Children demonstrate conceptual faculties which enable this process, and assure the transfer of STEM knowledge. This study also confirmed the ease of transmission this knowledge, in spite of linguistic barriers. Early childhood toddlers were capable of making complex conceptual connections. In Transcription 03, a child was asked to identify a healthy food, and responded by selecting an apple. This implies children inculcate knowledge of nuanced ideas (e.g. healthy), the cause-and-effect impact on the human body, and how those results are achieved. This cause and effect knowledge forms the basic foundations of empirical thought. Empirical thought, of course, guides STEM knowledge.

In addition to visual recognition, and conceptual dynamics, this study examined quantitative reasoning. Using a visual appeal, the confederate in the study reinforced quantitative knowledge in the subject. This implies both visual and technological tools, suited for early development toddlers, can inculcate STEM knowledge in early stages. Quantitative reasoning can be achieved in ways accessible to toddlers. Technology and visual aids can stimulate comprehension when embedded in the proper format. The study also compels one to reconsider traditional teaching roles. Firstly, parents can initiate the transfer of STEM concepts through technological means. Accordingly, learning is more than a passive process, but rather, a collective and interactive one.

A few limitations arose in the course of this study. The study results are not generalizable to populations. The sample size was too small to account for cognitive trends in the general population. In order to reproduce these trends, and verify the generalizable effective of these methods, a large sample size is needed in the future. Another limitation is the lack of definable variable and empirical measures of that variable.

This has massive implications for future studies in regards to STEM knowledge for early developmental stages. Researchers can utilize these findings to facilitate the science and engineering gap in Westernized nations. Western children lag considerably in comparison to Chinese children in STEM education. Mitigating this gap, in early developmental years, can bypass discrepancies in the future.

## REFERENCES

- Al Musawi, A. S. (2011). Redefining technology role in education. *Creative Education*, 2(2), 130-135. <https://doi.org/10.4236/ce.2011.22018>
- Aladé, F., Lauricella, A. R., Beaudoin-Ryan, L., & Wartella, E. (2016). Measuring with Murray: Touchscreen technology and preschoolers’ STEM learning. *Computers in Human Behavior*, 62, 433-441. <https://doi.org/10.1016/j.chb.2016.03.080>
- Aronin, S., & Floyd, K. K. (2013). Using an iPad in inclusive preschool classrooms to introduce STEM concepts. *Teaching Exceptional Children*, 45(4), 34-39. Retrieved from [https://www.researchgate.net/publication/259383269\\_Ms\\_Using\\_an\\_iPad\\_in\\_Inclusive\\_Preschool\\_Classrooms\\_to\\_Introduce\\_STEM\\_Concepts](https://www.researchgate.net/publication/259383269_Ms_Using_an_iPad_in_Inclusive_Preschool_Classrooms_to_Introduce_STEM_Concepts). <https://doi.org/10.1177/004005991304500404>
- Basham, J. D., & Marino, M. T. (2013). Understanding STEM education and supporting students through universal design for learning. *Teaching Exceptional Children*, 45(4), 8-15. <https://doi.org/10.1177/004005991304500401>
- Becker, K., & Park, K. (2011). Effects of integrative approaches among science, technology, engineering, and mathematics (STEM) subjects on students’ learning: A preliminary meta-analysis. *Journal of STEM Education: Innovations and Research*, 12(5/6), 23.
- Belland, B. R., Walker, A. E., Kim, N. J., & Lefler, M. (2017). Synthesizing results from empirical research on computer-based scaffolding in STEM education: A meta-analysis. *Review of Educational Research*, 87(2), 309-344. <https://doi.org/10.3102/0034654316670999>



- Breiner, J. M., Harkness, S. S., Johnson, C. C., & Koehler, C. M. (2012). What is STEM? A discussion about conceptions of STEM in education and partnerships. *School Science and Mathematics, 112*(1), 3-11. <https://doi.org/10.1111/j.1949-8594.2011.00109.x>
- Brenneman, K. (2011). Assessment for Preschool Science Learning and Learning Environments. *Early Childhood Research & Practice, 13*(1), n1.
- Chen, H. R., & Tseng, H. F. (2012). Factors that influence acceptance of web-based e-learning systems for the in-service education of junior high school teachers in Taiwan. *Evaluation and program planning, 35*(3), 398-406. <https://doi.org/10.1016/j.evalprogplan.2011.11.007>
- Chesloff, J. D. (2013). STEM education must start in early childhood. *Education Week, 32*(23), 27-32.
- Clabaugh, C., Ragusa, G., Sha, F., & Matarić, M. (2015, August). Designing a socially assistive robot for personalized number concepts learning in preschool children. In *Development and Learning and Epigenetic Robotics (ICDL-EpiRob), 2015 Joint IEEE International Conference on* (pp. 314-319). IEEE. <https://doi.org/10.1109/DEVLRN.2015.7346164>
- Corlu, M. S., Capraro, R. M., & Capraro, M. M. (2014). Introducing STEM education: implications for educating our teachers for the age of innovation. *Egitim ve Bilim, 39*(171).
- DeJarnette, N. (2012). America's children: Providing early exposure to STEM (science, technology, engineering and math) initiatives. *Education, 133*(1), 77-84. Retrieved from [https://www.researchgate.net/profile/Nancy\\_DeJarnette/publication/281065932\\_America%27s\\_Children\\_Providing\\_early\\_exposure\\_to\\_STEM\\_Science\\_Technology\\_Engineering\\_Math\\_Initiatives/links/56e8a01208ae166360e52647/Americas-Children-Providing-early-exposure-to-STEM-Science-Technology-Engineering-Math-Initiatives.pdf](https://www.researchgate.net/profile/Nancy_DeJarnette/publication/281065932_America%27s_Children_Providing_early_exposure_to_STEM_Science_Technology_Engineering_Math_Initiatives/links/56e8a01208ae166360e52647/Americas-Children-Providing-early-exposure-to-STEM-Science-Technology-Engineering-Math-Initiatives.pdf)
- Land, M. H. (2013). Full STEAM ahead: The benefits of integrating the arts into STEM. *Procedia Computer Science, 20*, 547-552. <https://doi.org/10.1016/j.procs.2013.09.317>
- Langdon, D., McKittrick, G., Beede, D., Khan, B., & Doms, M. (2011). *STEM: Good Jobs Now and for the Future*. ESA Issue Brief# 03-11. US Department of Commerce.
- Leveson, N. (2011). *Engineering a safer world: Systems thinking applied to safety*. MIT press.
- Marginson, S., Tytler, R., Freeman, B., & Roberts, K. (2013). *STEM: country comparisons: international comparisons of science, technology, engineering and mathematics (STEM) education*. Final report.
- Mundkur, N. (2005). Neuroplasticity in Children. *Indian Journal of Pediatrics, 72*. <https://doi.org/10.1007/BF02731115>
- Quang, L. X., Hoang, L. H., Chuan, V. D., Nam, N. H., Anh, N. T. T., & Nhung, V. T. H. (2015). *Integrated Science, Technology, Engineering and Mathematics (STEM) Education through Active Experience of Designing Technical Toys in Vietnamese Schools*. arXiv preprint arXiv:1509.03807.
- Robelen, E. W. (2011). STEAM: Experts make case for adding arts to STEM. *Education week, 31*(13), 8.
- Stohlmann, M., Moore, T. J., & Roehrig, G. H. (2012). Considerations for teaching integrated STEM education. *Journal of Pre-College Engineering Education Research (J-PEER), 2*(1), 4. <https://doi.org/10.5703/1288284314653>

## APPENDIX A

## Transcription 01: Colors

Context	Drawing with oval shaped bicolor crayons
Time	06/01/2018 afternoon
Duration	5 minutes
*MOM:	okay, what's the color ?
*TOM:	Chengse@ch (orange) .
*MOM:	chengse@ch (orange) yingyu@ch (English) jiao@ch (Call) shenme@ch (what)
*TOM:	orange
*MOM:	orange ?
*TOM:	Orange! Orange!
*MOM:	YES, orange, very good.
*MOM:	And, only orange?
*TOM:	hai@ch (still) you@ch (have) lvse@ch (green) .
*MOM:	lvse@ch (green), in English?
%act:	point to the green side of the crayon
*TOM:	It [/] it's g& [/] g&, green.
*MOM:	this is green, right.
*MOM:	Remember! yingyu@ch (English) jiao@ch (call) green.
*TOM:	Ah.
%act:	Nod his head.
*MOM:	right then how about this crayon?
%act:	point to the blue and red crayon.
*TOM:	Nayige@ch (which one)
*MOM:	This one, this one.
%act:	point to the blue side.
*TOM:	Lanse@ch (blue) de@ch (of) ma?@ch (interrogative marker)
*MOM:	In English.
*TOM:	Blue.
*MOM:	Blue and ?
*TOM:	<Blue and> [/] <Blue and> [/] Blue and red
%act:	Upside down the oval shaped bicolor crayon
%act:	point to the red side
*MOM:	Yes, good job.
*TOM:	huangse@ch (yellow) shi@ch (be) yellow ma?@ch (interrogative marker)
%act:	point to the yellow side of another crayon
*MOM:	Yes, it's yellow.
*TOM:	Eh...
*TOM:	Zhege@ch (this) jiao@ch (call) shenme@ch (what)
%act:	point to the purple side of another crayon
*MOM:	Purple
*TOM:	Bubble?
*MOM:	Not water bubble for bath, it's purple
*TOM:	Purple grape?
*MOM:	Yeah! Purple grape
*TOM:	orange too?
%act:	point to the pink side of another crayon
*MOM:	It's not orange.
*TOM:	Red [/] hongse@ch (red)?
*MOM:	It's not so red [/] it's a little red [/] it's pink
%act:	Think about how to explain the pink color
*TOM:	Pink shi@ch (shi) shenme@ch (shenme) yanse@ch (color)
*MOM:	shi@ch (be) fenhong@ch (pink, literally it means "powdered red") se@ch (color)
*EDW:	fenhongse@ch (powdered red color) jiushi@ch (be) pink ma?@ch (interrogative marker)
*MOM:	Yes, Thomas.
*TOM:	Eh, it's pink and [/] and [/] black.
*MOM:	Great! Clap for Thomas!
%act:	Clap hands
*TOM:	Eh.
%act:	Smile with teeth and run quickly to find toys.

## Transcription 02: Fruit and Vegetables

<b>Context</b>	<b>In the kitchenette designed for children with plastic fruit and vegetables</b>
<b>Time</b>	<b>10/01/2018 morning</b>
<b>Duration</b>	<b>4 minutes</b>
*TOM:	fruit is vegetable?
*MOM:	Well, no, fruit is fruit and vegetable +// is vegetable
%act:	Apple in the left hand and cabbage in the right hand
*TOM:	apple is fruit?
%act:	Take the plastic apple from mother's hand
*MOM:	Yeah, apple is fruit
*MOM:	And more fruit?
*TOM:	Banana is fruit?
%act:	take a banana from the basket
*MOM:	Yes, it is and find more fruit.
*TOM:	Pear, grape, peach and zhege@ch (this one) jiao@ch (call) shenme@ch (what)
*MOM:	Papaya.
%act:	point to the plastic fruit which seems to be a papaya
*TOM:	Papaya zhongwen@ch (in Chinese) shi@ch (be) shenme@ch (what)
*MOM:	mugua@ch (papaya, literally it means "wooden melon" )
*TOM:	Na@ch (then) xigua@ch (watermelon, literally it means "west melon") yingyu@ch (in English) jiao@ch (call) shenme@ch (what)
*MOM:	Watermelon.
*TOM:	Shui@ch (water) gua@ch (melon)?
*MOM:	Yes, watermelon is melon of water. Limian@ch (inside) you@ch (have) xuduo@ch (a lot of) shui@ch (water)
*TOM:	Waterlemon is fruit?
*MOM:	Yes, of course.
*MOM:	And What's this?
%act:	Point to the potato
*TOM:	patata@sp (potato)
*MOM:	Sí@sp (yes), ¿en@sp (in) inglés@sp (English)?
*TOM:	Pa& pa& p&
*MOM:	Po-ta-to.
*TOM:	Potato shi@ch (shi) yingyu@ch (English) ma?@ch (interrogative marker)
*MOM:	Yes, so Potato in English, Patata@sp (Potato) en@sp (in) inglés@sp (English), zhongwen@ch (Chinese) jiao@ch (call) shenme@ch (what)
*TOM:	Tudou@ch (potato)
*MOM:	Do you like potatos?
*TOM:	...
%act:	Keep silent, it seems he doesn't understand the question.
*MOM:	Te@sp (to you), gustan@sp (like), patatas@sp (potatos)? (This spanish sentence means "do you like potatos".)
*TOM:	Sí@sp (yes)
*MOM:	Thomas, is it fruit or vegetable?
*TOM:	Vege&
%act:	Try to find other items in the basket

### Transcription 03: Healthy Food

Context	In the kitchenette designed for children with plastic fruit and vegetables
<b>Time</b>	<b>10/01/2018 morning</b>
<b>Duration</b>	<b>4 minutes</b>
*MOM:	Thomas, find one food that is healthy for us.
*TOM:	Apple?
%act:	Grab an apple in his right hand
*MOM:	And more healthy food.
*TOM:	This.
*MOM:	Is carrot healthy food?
*TOM:	Eh.
*MOM:	Ok. And, is this healthy food?
%act:	Take out a bar of chocolate from the pocket
*TOM:	Yes +//. No, No, No. wo@ch (I) yao@ch (want) chi@ch (eat) qiaokeli@ch (chocolate) [/]wo@ch (I) yao@ch (want) chi@ch (eat) qiaokeli@ch (chocolate) [/]wo@ch (I) yao@ch (want) chi@ch (eat) qiaokeli@ch (chocolate)
*MOM:	Chocolate is not healthy, not good.
%act:	Wiggle left index finger to show the meaning of "no"
*TOM:	wo@ch (I) yao@ch (want) chi@ch (eat) qiaokeli@ch (chocolate) [/]wo@ch (I) yao@ch (want) chi@ch (eat) qiaokeli@ch (chocolate) [/]wo@ch (I) yao@ch (want) chi@ch (eat) qiaokeli@ch (chocolate)
%act:	Tend to cry
*MOM:	So only one chocolate a day, okay?
%act:	Split a little piece of chocolate and pass it to Thomas
*MOM:	So, how many time a day?
*TOM:	...
%act:	Show his right index finger to express the number "one"
*MOM:	So, how many time a day?
*TOM:	One. No, two!
*MOM:	One!
*TOM:	Okay, one. Dangao@ch (cake) ne? @ch (interrogative marker)
*MOM:	One cake a day
*TOM:	Lollipop?
*MOM:	No lollipops.
*TOM:	You@ch (have) [/] You@ch (have), bingxinag@ch (refrigerator) limian@ch (inside) you@ch (have)
*MOM:	Is lollipop healthy food? Is lollipop good?
%act:	Thumb up
*TOM:	Not good
*MOM:	So one lollipop a week.
*TOM:	Yi@ch (one) zhou@ch (week) yi@ch (one) ge@ch (item) ma?@ch (interrogative marker)
*MOM:	Yes, one week.

### Transcription 04: Counting Animals

<b>Context</b>	<b>Playing with toy animals after lunch</b>
<b>Time</b>	<b>5/02/2018 afternoon</b>
<b>Duration</b>	<b>4 minutes</b>
*MOM:	One two and?
*TOM:	Three.
*MOM:	Ok, so next question, one....
%act:	Index finger form one
*MOM:	one plus one?
*TOM:	two .
*MOM:	what's this animal?
*TOM:	Eli. (Elephant, an imitation of the cartoon titled Pocoyo)
*MOM:	Full name.
*TOM:	Elephant.
*MOM:	right, one plus two ? how many elephants right now?
%act:	Put three flashcard together
*TOM:	Two.
*MOM:	one plus two, look.
%act:	Show one figure with left hand and two fingers with the right hand
*TOM:	Dengyu@ch (equal to) san@ch (three) ma?@ch (interrogative marker)
*MOM:	Yes. So one plus two is ?
*TOM:	Three.
*MOM:	Ok what's the next, which animal? Moew, Moew
*TOM:	Cat moew.
*MOM:	Yes.
*MOM:	So how many moew moew cats can you see?
%act:	Show four flashcards of cats. Two cards with left hand and two with right hand
*MOM:	Two plus two?
*TOM:	Three.
*MOM:	Let's count, one, two, three, four. How many?
*TOM:	Meow, Meow, Meow, Meow.
*MOM:	So how many meows?
*TOM:	Sige@ch (four items).
*MOM:	what's the animal ?
*TOM:	...
%act:	Wiggle his head
*MOM:	Oh, John the ra& (lyric of a kid song "John the Rabbit")
*TOM:	Ra&, Ra&, Rabbit.
*MOM:	Great. How many rabbits?
*TOM:	Xiao@ch (little) tuzi@ch (rabbit) yao@ch (will) shujiao@ch (go to sleep) le@ch (accomplishment aspectual marker)
%act:	Run quickly to another room.

### Transcription 05: Plus and Minus

<b>Context</b>	<b>Playing before sleep</b>
<b>Time</b>	<b>8/02/2018 night</b>
<b>Duration</b>	<b>5 minutes</b>
*MOM:	Thomas, one plus three?
*TOM:	one y@sp (and) three, four.
*TOM:	Sí@sp (yes)?
%act:	point to himself
*MOM:	Yes ,it's four. Very good.
*MOM:	And I have two books and you have two books. How many books now?
*TOM:	Mama@ch (mother) you@ch (have) liangge@ch (two items), wo@ch (I) you@ch (have) liangge@ch (two items).
%act:	Try to count with fingers but fail to find solution
*MOM:	So how many books?
*TOM:	No.
%act:	Wiggle his head
*MOM:	Look, one book, two books, three books and?
%act:	show four small picture books
*TOM:	siben@ch (four) shu@ch (books)
*MOM:	Yes, in English?
*TOM:	Four ks& [/] four books.
*MOM:	So I take one book away, how many left now ?
%act:	Take a book and place it behind her
*TOM:	One, two, three.
*MOM:	So how many?
%act:	Point to the tree books on the table
*TOM:	Three.
*MOM:	Then four minus one is ?
%act:	Point to the tree books on the table
*TOM:	Three.
*MOM:	Then three minus one?
%act:	Take a book and place it behind her
*TOM:	One two. And two.
*MOM:	Ok, then two minus one ?
%act:	Point to the only book left on the table
*TOM:	Mama@ch (mother) Zhi@ch (only) sheng@ch (leave) yiben@ch (one volume) le@ch (accomplishment aspectual marker)
%act:	Show kind of afraid of the reduction of number

<http://www.ejmste.com>



# Monitoring of the Educational Process with the Use of Information and Communication Technologies: A Case Study in Computer Science

Natalia Barinova <sup>1\*</sup>, Venera Zakirova <sup>2</sup>, Daniya Akhmetova <sup>3</sup>, Lyudmila Lysogorova <sup>4</sup>

<sup>1</sup> Bashkir State Pedagogical University named after M. Akmullah, Ufa, RUSSIA

<sup>2</sup> Kazan (Volga region) Federal University, Kazan, RUSSIA

<sup>3</sup> Kazan Innovative University named after V.G. Timiryasov, Kazan, RUSSIA

<sup>4</sup> Samara State University of Social Sciences and Education, Samara, RUSSIA

Received 8 June 2017 • Revised 24 October 2017 • Accepted 25 November 2017

## ABSTRACT

The main goal of the present paper is to get a feedback of the Computer Science lessons in order to introduce consecutive changes in Computer Science curriculum for enhancing the efficiency of the educational process. One of the prospective ways of solving such a problem is the use of information and communication technologies that help searching for an option for enhancing the efficiency. The aim of the current research is to develop monitoring of the educational process at the Computer Science lessons with the use of information and communication technologies and the implementation of the process concerning teachers' deliberate acquirement of monitoring skills. The essential method is monitoring that can improve the state of schooling at the Computer Science lessons by means of identifying problems and deliberate individual work. The paper deals with the step-by-step algorithm of the monitoring implementation at the Computer Science lessons. This algorithm includes the following stages: introductory and motivational, reproductive self work, productive self work and final stage. The peculiarity of monitoring is its traceability of the educational process, a phased examination and progress assessment at the Computer Science lessons. The implementation of phased monitoring at the Computer Science lessons aims at classroom management, the development of educational work and impartial progress assessment.

**Keywords:** monitoring, monitoring of the educational process, information and communication technologies

## INTRODUCTION

### The Timeliness of the Research

Modern graduates must have sufficient fundamental education to be able to build on this foundation new knowledge in accordance with the new conditions. Computer Science is one of the foundations that are laid at school (Lebedeva et al., 2018). Limits of the use of information and communication technologies in our life and human activities are constantly expanding. That means that the requirements to the quality of teaching have been increasing. At the same time, the rapidly increasing information flows in the modern world and the need for its processing require the introduction of new information technologies into the educational process at the Computer Science lessons not only at the training stage, but also at the stage of academic performance rating. However, during the teaching process teachers and students do not have a complete picture of students' progress despite the comprehensive facilities. Traditional assessment system of students' knowledge because of its organizational

© 2018 by the authors; licensee Modestum Ltd., UK. This article is an open access article distributed under the terms and conditions of the Creative Commons Attribution License (<http://creativecommons.org/licenses/by/4.0/>).

✉ [nataliinf@mail.ru](mailto:nataliinf@mail.ru) (\*Correspondence) ✉ [zakirovav-2011@mail.ru](mailto:zakirovav-2011@mail.ru) ✉ [ahmetova@ieml.ru](mailto:ahmetova@ieml.ru)

✉ [lasogorova@gmail.com](mailto:lasogorova@gmail.com)

#### **Contribution of this paper to the literature**

- There is phased monitoring of the Computer Science lessons intending diagnostics, analysis of successfulness of the implementation of every stage at classes and a timely correction of all its components. Teaching activities in monitoring allow implementing a qualitative approach to the educational process.
- A plan for the use of information and communication technologies based on the objectives of each stage of monitoring at the Computer Science lessons and at the whole lesson with the aim of individualization and differentiation of training is proposed in the article.
- Educational program is designed for teachers to understand the content of monitoring of the educational process with the use of information and communication technologies involving teachers in interactive communication for creating their own trajectories during methodological work is developed.

capabilities and technological features cannot supply the needs of the community (Rozhina & Baklashova, 2018). The results are not complete and they are very difficult to be used for getting objective quantitative and qualitative indicators allowing controlling the quality of education. Computer Science is an exact science and has a clear algorithmic construction and possibility of reasonably accurate measurement of knowledge, abilities and practical skills of the students.

The effectiveness of Computer Science teachers depends on the way they perform the functions of controlling the results and provide objective feedback which is expressed in the structural orderliness and direct all activities and all participants of the educational process to the achievement of certain results and making operational decisions on the training situation. The use of information and communication technologies will contribute to change control methods towards actuation of the educational activity, developing their consciousness, independence, individualization and interactivity.

Phased monitoring of the educational process at the Computer Science lessons with the use of information and communication technologies must be implemented for realizing this approach. Monitoring of the educational process at the Computer Science lessons is the procedure of traceability of educational results with the use of information and communication technologies throughout the system of control, information gathering and its processing. This system is a set of indicators analyze and role play the educational process which is aimed to the achievement of specific goals.

The use of information and communication technologies for implementation of monitoring the educational process at the Computer Science lessons gives the opportunity of immediate feedback. It reduces the time spent on unproductive mechanical work, gives time for teachers' to work in a creative way, allows to monitor students' are mastering basic knowledge and skills. It corrects the learning process at the same time personalizing it. The use of information gives opportunity to automatize a major part of the processes ensuring assessment activity - from preparing and measuring materials to assessing the students' learning results. (Kaptelinin, 1999; Mayer & Moreno, 2003; Schunk, 1982; Sorden, 2005; Tuninga & Seinen, 1995). Getting information concerning the progress of the educational process using communication technologies gives us understanding of its essence way better, giving us a chance to make adjustments if needed. Thus, monitoring provides a timely opportunity to interfere in the mechanisms and regularities of the educational process or personal development.

### **Goals and Objectives of the Research**

The main goal of this article is to develop phased monitoring of the educational process at the Computer Science lessons with the use of information and communication technologies. The main objectives would be the following: to study the possibilities of information and communication technologies for monitoring of the educational process; to implement appropriate stages of organization and to implement monitoring of the educational process at the Computer Science lessons with the use of information and communication technologies; to study pedagogical experience of teachers, revealing their relations to the systematic traceability of the educational process and their belief in the need for its implementation; to go through new ways of the theory of pedagogical monitoring, the use of information and communication technologies in the methodical activity of a teacher.

## **MATERIALS AND METHODS**

### **Methods of the Research**

Monitoring of the educational process at the Computer Science lessons has been used as the main method. The implementation of this method includes such stages as introductory and motivational, reproductive and productive independent work of students. The effectiveness of implementing phased monitoring at the Computer Science

lessons is determined by the degree of the use of information technologies and implementation of joint monitoring activities of teachers and their students ensuring the co-evolution of their monitoring abilities.

Phased monitoring involves diagnostics, analysis of successful implementation of training classes and timely correction of all structural components (Pyl, 1989). Pedagogical expedience of the use of information and communication technologies at each stage of monitoring of the educational process at the Computer Science lessons is determined by the aims and contents of each stage and is based on the methodological purpose of this or that software (PC). Teaching activities in monitoring at the Computer Science lessons with the use of information and communication technologies allow implementing a qualitative approach to the educational process.

At each stage of monitoring of the educational process the most important methodological goals during the effective use of information and communication technologies would be the following:

1. Individualization and differentiation of process of training (for example, using the individual educational trajectory).
2. Feedback control and problem solving as a result of the study (to state the causes of erroneous actions of the student and to represent some of them on the computer screen) and assessment progress.
3. Self-monitoring and self-correction.
4. Perform trainings during the process of learning and students' self-study.
5. The release of study time due to the doing computationally-intensive tasks and activities associated with the computational analysis on the computer.
6. Computer visualization of educational information (first, the studied object (a visual representation of the object, its parts or its models, and if necessary, showing it from all angles, in detail with the ability to show the internal relationships of the constituent parts on the screen); second, the investigated process (a visual representation of the process or its model on the screen including some hidden elements in the real world, and if necessary, in development, in temporal and spatial motion, graphical representation of interpretation of the patterns of the studied process).
7. Modeling and simulation of studied or investigated objects, processes or phenomena.
8. The laboratory work in the simulated conditions via the computer program of real experience or experiment.
9. The creation and usage of databases required in training activities and providing access to information network.
10. Enhancing learning motivation (e.g., by visual means or game situations).
11. Introducing a training strategy to the students.
12. The development of a certain kind of thinking (visual-imaginative, theoretical, etc.).
13. Formation of skills to make the best decision or alternative decisions in a difficult situation.
14. The formation of culture of training activities and information culture (for example, by means of systematic work on texts, databases, presentations, integrated custom packages).

The didactic potential is taken into account whenever we select information and communication technologies. ICT is used comprehensively in accordance with the content of the training material, objectives of the monitoring phase of the training process individually and in general. The teacher also carries out the selection of software used in the classroom. In the absence of the required ICT learning, the teacher creates new learning tools that enhance the effectiveness of learning.

The use of monitoring at the Computer Science lessons allows the teacher to perform as a facilitator and as a consultant based on objective information through the direct management of the process of students' acquirement of the educational material using information and communication technologies. The use of monitoring allows implementing a qualitative approach to the educational process, working in subject-subject relations (Asadullin, 2016; Louie, Drevdahl, Purdy, & Stackman, 2003), eliminating the psychological barrier of uncertainty in own forces while working on the PC, generating the willingness and the need to analyze and evaluate own activities as well as to apply information technology for solving professional and personally important problems (Bundick, Quaglia, Corso, & Haywood, 2014; Shaffer, Nash, & Ruis, 2015).

The main goal of the educational process is to master knowledge and skills not lower than at a predetermined level. The difference in educational results will take place outside the requirements for obligatory learning results.

The process of learning is not simply the result of teachers' work and students' reactions but a complex of combined efforts, their unification for achieving joint objectives and solving co-joint tasks. Striving to the rational activity and economical actions of the students is the strategic intent that underpins the plan of the learning process in the framework of monitoring of the educational process using information and communication technologies.

The set of methods for students' influence, searching modes of their work, selection of options, the conversion of an educational material into an accessible one for perception, understanding and appreciation of the elements (Edmunds, 2008), the organization of the gradual formation of the cognitive activity are provided by phased monitoring of the lessons.

### **The Research Phases**

The organization of monitoring the educational process at the Computer Science lessons with the use of information and communication technologies was set to solve three main sets of tasks.

The first set includes the formation of various groups according to the intellectual and practical skills that are necessary for the successful implementation of each stage of the educational process at the Computer Science lessons with the use of information and communication technologies. This set of tasks was also aimed at updating of professional experience and teachers' creative potential.

The second set is designed in such a way that teachers, who acquainted with foreign and Russian experience in monitoring of educational process at the Computer Science lessons. This way the results of national and international comparative studies such as (PISA, TIMSS, etc.) will gain personal, motivational-valued attitude to the systematic tracking of the educational process using information and communication technologies and become convinced of the necessity of its implementation.

The third set is connected to the system of knowledge that reveals the essence, structure, functions and methods of implementation of pedagogical activity in e-learning and also the essence of monitoring and its role in professional activity of the teacher, methods and forms of its implementation in remote collaborative activities with students.

## **LITERATURE REVIEW**

The analysis of psychological and pedagogical literature gave us an idea that there was a certain amount of knowledge that was necessary for the formulation and solution to the problem being studied in modern science. In this research we analyzed local and foreign experience in the use of information and communication technologies in professional activity of the teacher.

The use of information and communication technologies in professional activity of the teacher is explained by the fact that they provide not only high-level visibility and allow organizing various forms of pedagogical interaction. They transfer the necessary complex of didactic materials in electronic form that enriches traditional forms of educational activities, improve the efficiency of educational systems, the quality of training students in general (Chen, 2011; Khan, Bibi & Hasan, 2016; Pange, 2004; Robertson, 2003). The quality of students' training characterizes the result of educational activity – the level of readiness, but also the factors of this result, which depends on the purpose of education, content and methodology of organization and technology. All of the mentioned characteristics are the characteristics we consciously influence on and that are necessary to be managed (Burbules, 2004; Cochran-Smith, 2003; Csapo, 2007; Hollins, 2011; Hsieh, Law, & Shy, 2011; Nair, Webster, & Mertova, 2010; Wang, Lin, Spalding, Klecka, & Odell, 2011). Development and foundation of monitoring as a system for tracking the educational process and improving its quality, objectives, tasks, implementation mechanisms and indicators are disclosed in the works written by Richards (1988), Bedesem and Dieker (2013), Ghatala (2011), Ballou and Springer (2015). The establishment of a system of educational monitoring provides an objective assessment of the level of training and quality of students' knowledge. Analysis of the results of educational activity makes it possible to identify ways of overcoming results that have to be improved in education quality (Näykki, Järvenoja, Järvelä, & Kirschner, 2017; Seo, McGrane & Taherbhai, 2015; Usova, 2002).

## **RESULTS**

### **Phased Monitoring of the Educational Process**

In this part we will discuss the monitoring system of the educational process at the Computer Science lessons.

All learning activities are normally divided into 4 main stages: introductory and motivational stage (questionnaires, goal-setting, regulation, organization, independent work); reproductive independent work of students; productive independent work of students; the final stage. Each of these stages use information and communication technologies.

The progress of the classes has been defined with the help of a qualitative implementation of each stage that had been monitored, diagnosed, predicted and adjusted in a certain way. Information about each stage at the training sessions allowed the teacher to analyze the way the tasks that had been developed at different stages of

**Table 1.** Indicators of implementation of each stage

Stages	Steps	Teachers'/students' activities	Indicators
I stage	1 step	Questionnaire, presentation of the goal, objectives and structure.	Positive attitude to the process of learning, students' judgments about the upcoming activities, they are interested in the studied subject.
	2 step	Goal-setting and regulation.	Students take up the goals: mainstreaming them into the activity.
	3 step	Presentation of the topic to the students, explanation of the algorithm of their independent work.	The questions, difficulties, inaccuracies among students concerning the implementation of independent work.
II stage	4 step	Management of students' independent work/ their independent work itself at the reproductive level.	Difficulties in doing tasks at the reproductive level, the total number of done obligatory assignments.
III stage	5 step	Management of students' independent work/ their independent work itself at the productive level.	Difficulties in doing tasks at the productive level, the total number of done assignments during a certain period of time.
IV stage	6 step	The regulation and assessment, analysis of the results through the category of educational goals in cognitive area/regulation and assessment.	The number of points in accordance with each module; the mark of a 5-point scale; discussion of results, aftereffect.

the educational process corresponding to the goals. At the same time it gave us opportunity to test the level of knowledge and depth of proficiency in skills based on the testing at the reproductive and productive levels. Some changes have been made in the case of deviations. The ability to design a system of monitoring at the Computer Science lessons, to define the place of each lesson in achieving joint goals and objectives, to communicate effectively with students, to use information and communication technologies effectively provided the achievement of high quality education.

We pointed out indicators of successful implementation of each stage of the lesson to make it possible for teachers to work with monitoring data of each stage (Table 1).

The first step of the introductory and motivational stage is a questionnaire survey with the purpose of obtaining information about the needs, attitudes, motives, i.e., willingness of students to study Computer Science.

Students can have a look at the program of the subject at the beginning of their independent work, its structure and main tasks on their e-mails or on a personal site of the teacher in order to orient themselves on the sequence of the problem study and the plan of their individual learning activity.

The second step "Goal-setting and normalization of the educational process" is necessary for the complete planning, task performance and independent work assessment.

The most important element of the monitoring structure of the educational process of the Computer Science lessons is to specify the objectives of the school subject through the levels of learning. In our work we formulated the goals of the process of learning as the results of the mentioned process expressed in the students' activity. The goals formulated in such a way meet diagnostic requirements.

A clear system of educational objectives in the cognitive area is used to implement this idea in the theory of educational monitoring. The hierarchy of levels of learning by Bloom (1956): knowledge, comprehension, usage, analysis, synthesis, and estimation - is a most effective to use. This approach to goal-setting allows us to finalize the results of students learning, organizing flexible learning process, allocating the required levels of mastering the content of the subject by all the students and taking into account the individual needs of students.

The content of the school subject "Computer Science" was concretized through the learning objectives according to the levels of learning (Bloom, 1956) (Table 2).

**Table 2.** Goal-setting and normalization of educational activity of students at Computer Science

The levels of learning of educational goals	Students' activities	Points (the range of estimated figures)
Knowledge	Name the possibilities of the PC as a means of information, communication, organization, professional activity, leisure	Up to 2
	Name the rules of working on the PC	Up to 1
	Name basic PC devices	Up to 1
	Enumerate the order of turning the PC on	Up to 1
	Start a necessary program	Up to 1
	Finish work with the program	Up to 2,5
	Turn the PC off	Up to 1
	Save a document in a personal folder, on the flash drive	2-6
	Name the need for utility key	3-8
	Find various symbols on the keyboard	1-4
	Use the cursor	2-6
	Use the computer mouse	2-6
	Name the functions of the left and right buttons of the mouse	2-6
	Recognize the necessary command according to its icon	1-4
	Name the rules of text entering	2-5
Name the basic rules of drawing	2-5	
Comprehension	Recognize and responds to computer messages	2-5
	Create a text document in different ways	4-10
	Create a graphic document in different ways	4-10
	Save information in different ways	4-10
	Open the program for working with a necessary document	2-7
	Open text and graphic documents	2-5
	Edit text and graphic documents	4-10
	Interpret teacher's task before doing it on the PC	5 -11
	Show different possibilities of PC to do a particular task	7-12
	Explain why he/she worked in a certain order	2-7
Usage	Help another student in doing task	3-8
	Follow the rules of working on the PC	3-8
	Use various formatting attributes of symbols and paragraphs when editing documents	11-17
	Carry out the most rational number of actions while doing a task	11-17
	Prepare enumerated, marked and multilevel lists	11-17
	Create and complete a table	11-17
	Demonstrate various options for preparing tabular data	11-17
	Print the document	1-4
	Use graphics of the text editor when creating schemes and charts	11-17
	Use ready graphic objects of the text editor when editing documents	11-17
Analysis	Use objects created in other applications while preparing documents	11-17
	Enumerate the capabilities of the text editor	1-4
	Enumerate the capabilities of the graphics editor	1-4
	Name the advantages and disadvantages of the graphics editor in certain situations	9-13
	Compare graphics capabilities of a word processor with the capabilities of the graphics editor	9-13
Synthesis	Suggest some options of preparing documents using various effects	10-14
	Suggest different ways of presenting information	10-14
	Combine different actions on the PC while preparing a new document from various documents on the proposed structure	11-15
	Complete a task in the graphics editor	11-17
	Complete a task in the text editor	11-17
Estimation	Complete a task using graphics, text editors and spreadsheet	19-25
	Consider the significance of using a computer in professional activity	9-13
	Discuss the prospects of computer application both in professional and personal life	17-23
	Consider the computer as a source of information, communication, means of recreation, i.e. from the point of personal needs	19-25
	Discuss the importance of using the computer in professional activity and personal life	17-23

The optimization of the educational process has been made taking into account the following goals:

- educational modules have been developed from the point of view of regulation time as well as in points. :  
 "Information and information processes" - 4 hours (22 points); "PC key information " - 4 hours (25 points);  
 "Paint" - 6 hours (40 points); "Word" - 20 hours (55 points); " Software System " - 4 hours (30 points);  
 "Windows graphic environment" - 4 hours (25 points); "MS-Excel spreadsheet " - 10 hours (45 points);  
 "Creating PowerPoint presentations" - 14 hours (25 points); "Computer communications" - 4 hours (20 points);



- electronic textbooks, reference materials, handouts have been developed, textbooks and reference books that students needed for independent work had been selected for the informational support of the educational process;
- training exercises that help to organize the students' work at reproductive and productive levels have been developed to practice skills on the PC.

The teacher is not enough to develop goal-setting tools. It is of a vital importance to achieve adoption of the goals and standards between students. Discussion of goals, methods and forms of work, opportunities of PC for the formation of needs and motivations among students have been introduced at this stage for the adoption of goals and standards. The discussion was held on the problem of goals and standards and their adoption in the form which they had been offered by the teacher. We should mention the fact that the quality of the whole educational process depends on the quality of this very important step.

The teacher goes over to the third step - introducing the topic of the lesson - as soon as students understand the objectives and norms. Students have been provided with the necessary information and handouts in electronic form with the major theoretical lay outs on the topic, exercises based on this theoretical material, control tasks.

After the discussion in a form of a dialogue the algorithm of personal work that students had to comprehend for completing the task. The discussion presupposes "good" students until everybody understands "what?", "what for?", and "why?" they should do it. This discussion continues until all the issues and difficulties are sorted out and only after that the teacher can pass on to the second phase of monitoring. This discussion gives us a chance to identify all the difficulties and mistakes between the students before they start their personal work.

At the second stage - the stage of personal work, the activities are designed so that to control personal work by teachers (the fourth step). We considered teaching activities at this stage as a good help and support to students in order to complete their tasks successfully. Online or off-line consultations can be provided.

Students activity is reproductive by nature, they do their task according to the algorithm based on the information received as well as the basic skills PC practice. Tasks at this level correspond to knowledge, comprehension and usage.

As soon as the task is complete, students have an opportunity to conduct self-monitoring and self-checking procedures. They are to compare the results with the model presented in the electronic handouts. The problems can occur even if one follows the algorithm, so the teacher assists and consults those students who have difficulties and helps them in their personal work. Students are provided with a new task to complete as soon as all the problems or difficulties are sorted out.

The teacher admits those students who managed to complete the tasks without any difficulty to the current control/self-control. The teacher and students find out using the categories of educational objectives in the cognitive area whether students developed their PC skills and whether they can complete a more complicated tasks. If students are unable to complete the task, they are to return to the revision of the material.

Understanding the control tasks means that the teacher allows students to work independently at productive level (third stage, fourth step). The teacher controls personal work implementing tiered differentiation through ranking tasks according to the categories of educational objectives in cognitive area - analysis, synthesis and estimation.

At this stage mistakes can be avoided with the help of a teacher, the number of tasks that student can complete is unlimited. Time is the only parameter that we have to take in to consideration. That's why this help and consultation allow student to return to personal work only within given period of time. After tackling problems he/she gets a new task of productive level and continues to work personally until he/she satisfies the needs of the assessment.

As soon as a task is completed students present their work to the teacher. Students analyze the task and make corrections together with the teacher.

The main task here is to analyze completed work thoroughly and do a short-term forecasting: give the student the same task on the PC or give a student a more difficult task.

Students analyze the task and make corrections together with the teacher. Students can do an extra task to get some extra points if they are not satisfied with the results. The key factor is time. Teachers can offer students to complete different tasks encouraging their personal work in case they have extra time.

Teacher passes over to the final control as soon as the time is over. The student works personally without any help from the teacher or other students. After completing the task the student sums up his/her points and calculates the rating after learning the topic.

Together with the teacher students find out which topics are left. In case they have any, the student returns to the first step and do all these tasks on the new topic again. If there are no topics left and time is out, the student and the teacher pass on to the final stage.

**Table 3.** Regulation of educational activity

Type of activities	Points
Answering the question	3
Giving an answer with the use of additional information	4
Analysis	5-15
Abstract, summary, review, report	7
Solving the task in a written form as in an example	4
Independent work	8
Test	11
The student noticed a mistake and offer the possible answer	2
Solving a problematic task	12
Homework	2
Preparing visual materials	5-15
Taking part in Computer Science competitions	15
Making addition	2
Assistance to a student	2
Making a report based on the material	11
Making a crossword	3
Reflection	5
Making a report based on the information which was practically reviewed	10
Making a plan	5

**Table 4.** Coefficients which are used while assessing practical work and oral survey

Practical work	
Correct and early completing the task	1,2
The task is completed without any remarks and not lately than a deadline	1
The task is completed in time with 1 remark	0,9
The task is completed in time with several unimportant drawbacks	0,8
The task is completed in time with 2-3 remarks, additions or out-of-time without any remarks	0,5
Uncompleted task	0
Oral answer	
Answer without any remarks and with the use of additional information	1,2
Answer without any remarks	1
Answer with an unimportant drawback	0,9
Answer with several unimportant drawbacks	0,8
Answer is quite correct but there are several drawbacks which don't influence the understanding of the issue	0,7
There are some elements of the correct answer	0,5
No answer or wrong answer	0

The aim of the final control is to identify the level of acquisition of skills while working on PC.

The teacher checks how the results coincided with the goals through the categories of educational goals in the cognitive area. The comparison was made on the basis of information after current and final controls. The final figure is calculated on the regulatory basis summing up all the points while checking additional tasks, final control task and the system of coefficients that allow organizing not only quantitative but also qualitative control can be seen (Tables 3, 4).

The final point transforms in to the grade of a 5-scale basis. All the results are collected in a database and shown in the table of learning achievement for each student. The minimal point for each learning module is an obligatory level of learning this module. The regulation and assessment have been discussed with students. It is more important for those students who didn't manage to get minimal points. The teacher discussed with students the results of the regulation of the educational process, mistakes, time spent in order for the students to continue this work during the off-school hours. Students understand their final grade because they can monitor their results during the whole educational process and reflect on the regulatory basis.

Teacher makes corrections during the educational process. Teacher analyses the information during the whole process of education, monitors the difficulty of completing tasks. Teacher forecasts variable blocks which students can learn further on, forecasts the organization of the educational course for the next group taking into account the difficulties that have been disclosed in the previous assessments. He corrects the goals, regulations, tasks for self-work, methodology and forms of the educational process to increase the effectiveness of Computer Science learning.

That's why passing on the first stage of monitoring means the beginning of the new cycle of monitoring where teacher defines norms, tasks, difficulties, time etc.

### **Usage of Information and Communication Technologies**

Let's move over to the usage of information and communication technologies (ICT). Due to the fact that the realization of each stage of the educational process happens at Computer Science, the plan to use ICT is made according to the goals of each stage and the whole lesson.

The development of monitoring at the Computer Science lessons with the use of ICT includes the following stages:

1. Preparatory stage. At this stage a didactic goal is determined with the orientation to achieving the results (formation, consolidation, generalization or improvement of knowledge; formation of skills; learning control, etc.).

The need for ICT or Internet in the educational process is based on the pedagogical objectives of the lesson. The main objectives of ICT use: the possibility of presenting unique information materials in a multimedia form (movies, models, tables, charts, etc.); visualization of the studied phenomena, processes and relationships between objects; formation of skills of information search activities; the need to work with models of the studied objects, phenomena or processes in order to research them online, the use of ICT as an additional source of information.

Informative stage. Multivariate analysis and selection of electronic educational resources are based on the formulated requirements for the electronic educational resources on the didactic goals and methodic assignment. The form of the lesson and the key structural elements of the lesson are selected. More detailed analysis (improvement or upgrading) of electronic resources is conducted at this stage, the accompanying documentation is studied, the efficiency of the resource is predicted, the method of conducting a lesson is determined and principal activities of working with the resources in the educational process are developed.

Operational stage. Specification of functions of ICT and ways of their realization have been made at this stage. Different ways students interaction with electronic resources have been chosen; a detailed planning of the lesson has been carried out.

The purpose of ICT usage; the duration of the particular stage; a form of organization of students' activity using ICT; functions of the teacher and teacher's principal activities; form of the intermediate control with the use of ICT are determined for each of the stages of realization of monitoring of the educational process at the Computer Science lessons.

At the stage introduction and motivation (questioning, goal-setting, regulation, organization, independent work), one of the goals is to organize students to implement productive work, to consolidate knowledge that was used previously. The main ICT tools being used would be the following- presentations, e-learning resources (audio and videos) and interactive exercises for material assessments.

The main ICT for personal work of the students would be interactive presentations and discussions, Internet access (for getting additional information); diagrams, tables, interactive exercises, simulators, virtual labs with special software tools or modeling in MS Excel, computer experiment, computer simulations, problem solving, development of a short-term project using MS Power Point, MS Publisher, MS Word, Notepad.

At the final stage the main activity of ICT is a test implementation in order to consolidate the knowledge and develop the ability use it in professional work.

During this process students work using the computer with various educational software installed (supervising, coaching, demonstrative, learning), complete tasks with the use of text and graphics editors, calculate and recalculate using spreadsheets, use databases and a database management system, use electronic textbooks and manuals. Thus all students will have a great opportunity to work at the lesson at their own pace and the teacher can work with each student individually.

### **The Structure and Content of the Educational Program for Teachers**

"Monitoring of the educational process at the Computer Science lessons with the use of information and communication technologies" education program for teachers has been developed for successful implementation of the above mentioned blocks.

For successful implementation of the program it is highly recommended for teachers to have practical experience of (teaching and (or) managerial) activities with the use of ICT, understand the need for changes in the modern education, have PC skills and know how to search information in the Internet. They should be ready to accept new ideas and implement them.

The above mentioned program is designed to assist teachers in adapting to new conditions of professional activity in the field of education. The program is focused on the development of monitoring of the educational

process at the Computer Science lessons in the educational establishment. The program includes a number of lectures where the minimum of necessary theoretical information (definitions, approaches, international experience) is discussed. Seminars with specific examples and situations (from the teachers' practice) aimed at the gradual development of the program of monitoring of the quality of education in the system of e-learning by each teacher have been presented as well. Teachers provide students with everyday practice to clarify certain issues. The program can be mastered by any teacher because it is written on a modular principle where each module represents a complete unit of information, including training objective, guidelines, indicative framework for action and means of control (self-control).

Teachers who understand this program successfully:

- a) gain an impression of:
  - the monitoring as the informative basis of making decisions in educational management and of contemporary practice of education quality monitoring;
  - possibilities of monitoring as a leading means for managing education quality and choosing the strategy to develop pedagogical activities with the use of ICT;
- b) learn how:
  - to formulate the problem of analysis of development trends in pedagogical activities with the aim of designing an optimal monitoring program for the educational process at the Computer Science lessons;
  - to determine the sequence and content of steps in the development of program of monitoring of educational process with the use of information and communication technologies in practice;
  - to develop a methodology of monitoring, analyze results, and present the resulting information in the appropriate forms;
  - to determine the content and field of managerial decisions which are made using information obtained during the monitoring of the educational process at the Computer Science lessons;
- c) develop:
  - the sequence of managerial decisions made in conditions of transformation of pedagogical activities using ITC in education quality management on the basis of reliable information obtained during the monitoring;
  - the program of monitoring of the educational process in educational establishments taking into account the specific conditions of educational activity;
  - methodological package for monitoring of the educational process with the use of ITC including the tools and methodology of analyzing the results, local projects, information materials.

During the program development teachers are offered the following typical tasks: to analyze information; to prepare methods of monitoring; analyze practical experience of educational establishments, presentation of the results.

Personal oriented technologies that allow us to take all the teachers' requests are necessary to use during the program mastering. The main organizational forms would be lectures and practical lessons in the form of seminars, "round tables", group work and debates. Teachers work with the information personally during the task completion. The main mechanism of achieving the objectives of the program is to work with the cases which include professional orientations of teachers of different categories.

Duration of the program is 64 hours. Contact hours 30. Self work- 34. Computers and access to the Internet are necessary for successful mastering of the program.

The final control of the learning system is carried out through the presentation and public expertise.

### **Implementation of Educational Programs for Teachers**

Teachers use the materials and make presentations on the main routes of search and achievements in Russian and foreign pedagogy, in the field of education quality and e-learning during the academic year. Teachers analyze publications in magazines and materials in the Internet, participate in conferences, systematize their own experience, identify reserves of improving quality of education creating their own methods of monitoring federal state educational standards.

During the work on this program teachers were engaged in interactive communication. Lessons have been organized by the methodists and colleagues who wish to share their positive educational experience. Teachers who participate in distance learning and implement tests systematically. There were teachers who had already mastered the monitoring of the quality of education in e-learning and they were involved as developers of the lessons for their colleagues. They have been offered to work according to their own plan and sometimes they share the results

of activities with their colleagues. Teachers organize creative meetings, presentations, seminars, problem solving sessions ("Let's reflect..."), business and role games, trainings on different issues raised, "round tables" with different experts as speakers. This will provide any teacher with the possibility to improve and enhance its knowledge and skills through experience, understanding of the material on quality monitoring of education and using ICT. It will give opportunity to express their opinion, to share new knowledge and values, go through methodological findings with their colleagues.

Interaction created the atmosphere of goodwill and mutual support that contributed to the development of cognitive activity of teachers turning it into higher levels of cooperation.

Interactive forms of work allowe teachers to choose educational route (Khuziakhmetov & Sytina, 2016) in a certain direction (of adaptive type, educational and creative orientation) depending on the level of readiness of implementing the quality monitoring of educational process using e-learning technologies and the implementation of step-by-step algorithm of pedagogical interaction. This was also possible with the help of the methodical service that studied the educational needs for teacher. The implementation of monitoring activities in the system of e-learning evaluated together the resources of the educational establishment. It also formed a system of personal relations of the teacher to the development of e-learning technologies. Methodists provided methodological support of each trajectory of the teachers development.

## DISCUSSIONS

During the study of the educational process we pointed out disadvantages in methodical service's work with teachers on the organization of monitoring the educational process. We talk about the level of the object related to the passive learning methods which didn't allow us to create our own educational trajectory. Teachers do not associate the achievement of the results with the quality of the educational process. Teachers give priority while assessing the objective result of the learning activities of students. The subjective result expresses itself in the significance of the outcome for the learner's subjective satisfaction with the result, his/her psychological efforts (the cost of its efforts, the ratio of the capabilities of the student and his/her real success, matching the student's ability and efforts when performing this task).

Monitoring of educational process involved teachers in interactive communication, to create its own educational trajectories during a methodological work. Implementation of the step-by-step algorithm of pedagogical interaction allows each teacher to choose educational route in a certain direction (of adaptive type, educational and creative orientation) depending on the level of readiness to use monitoring systems during the lessons.

Phased monitoring of the lesson presupposes diagnosis, analysis of successful implementation of the stages and time correction of all structural components. Teaching activities in monitoring of the lessons allow us to implement a qualitative approach to the educational process. The effectiveness of the lessons was defined with a qualitative implementation of each stage that was monitored, diagnosed, predicted and adjusted. Joint monitoring activities of the teacher and the student provided a parallel evolution (co-evolution) of skills monitoring of the teacher and the student.

New questions and issues appeared during the research. The problem monitoring skills formation using e-learning technologies among future teachers at high school is of a great importance. It is necessary to continue the research of developing methods for the implementation of monitoring of the educational process using e-learning technologies in training and postgraduate education.

## CONCLUSION

Multiple use of monitoring of the educational process at the Computer Science lessons with the use of information and communication technologies can improve the learning process in a very good way. It can develop educational activities and contribute to the objectiveness of the assessment of learning results. Analysis of the obtained results during the monitoring at the Computer Science lessons help us to solve several important tasks: we talk about the tasks that are difficult for students; priorities in the work of the teacher with this or that student; working with individual data gives the opportunity to monitor the percentage of the task completion.

At the same time the monitoring of the educational process at the Computer Science lessons gives us a chance to asses: dynamics of the formation of the student during a certain period of learning, possibility to constantly adjust the work of the teacher based on the analysis of the dynamics; the opportunity for the teacher to know and to influence the strengths and weaknesses of the student and the whole class; systematic control of the quality of knowledge acquired by students taking into account individual abilities of students. An organized joint monitoring activity of the teacher and students will set parallel evolution of skills monitoring leads to the formation of adequate self-appraisal through self-examination. Learning process teachers can predict the success of the exam on the subject with the use of the training classes in preparation for the state exam and control tasks of A, B, C levels. The

use of information and communication technologies during the implementation of monitoring of educational process makes the process of learning more comfortable for students. Usage of the technologies such as animation, video and sound make studying events and phenomena more visible and therefore available for students. The use of ICT in monitoring of educational process allows teachers and students to arrange their working time in the classroom the way they want. Pre-prepared information for the lesson appears in the right time and in the aesthetic form. The saved time in the classroom can be used to increase the amount of information or training exercises. There is a need in the training of teachers for this activity during the introduction into the educational process and step-by-step monitoring. The educational program "Quality monitoring of education with the use of information and communication technologies" has been designed to assist teachers to adapt themselves to new era of professional activity in the field of education. The program is focused on the development of monitoring of the educational process at the Computer Science lessons in the educational establishment.

## ACKNOWLEDGEMENT

The work is performed according to the Russian Government Program of Competitive Growth of Kazan Federal University.

## REFERENCES

- Asadullin, R. (2016). *Pedagogics of the subject-oriented education*. Ufa: M. Aknulla BSPU.
- Ballou, D., & Springer, M. G. (2015). Using Student Test Scores to Measure Teacher Performance. *Educational Researcher*, 44(2), 77-86. <https://doi.org/10.3102/0013189X15574904>
- Bedesem, P. L., & Dieker, L. A. (2013). Self-Monitoring with a Twist. *Journal of Positive Behavior Interventions*, 16(4), 246-254. <https://doi.org/10.1177/1098300713492857>
- Bloom, B. S. (1956). *Taxonomy of educational objectives: The classification of educational goals*. New York: Longman.
- Bundick, M. J., Quaglia, R. J., Corso, M. J., & Haywood, D. E. (2014). Promoting Student Engagement in the Classroom. *Teachers College Record*, 116(4), 1-34.
- Burbules, N. (2004). Ways of Thinking about Educational Quality. *Educational Researcher*, 33(6), 4-10. <https://doi.org/10.3102/0013189X033006004>
- Chen, L. L. (2011). Improving Teachers' Teaching with Communication Technology. *Journal of Educational Technology Systems*, 40(1), 35-43. <https://doi.org/10.2190/ET.40.1.d>
- Cochran-Smith, M. (2003). Assessing Assessment in Teacher Education. *Journal of Teacher Education*, 54(3), 187-191. <https://doi.org/10.1177/0022487103054003001>
- Csapo, B. (2007). Research into learning to learn through the assessment of quality and organization of learning outcomes. *The Curriculum Journal*, 18(2), 195-210. <https://doi.org/10.1080/09585170701446044>
- Edmunds, J. A. (2008). Using Alternative Lenses to Examine Effective Teachers' Use of Technology with Low-Performing Students. *Teachers College Record*, 110(1), 195-217.
- Ghatala, E. S. (2011). Strategy-Monitoring Training Enables Young Learners to Select Effective Strategies. *Educational Psychologist*, 21(2), 43-54.
- Hollins, E. R. (2011). Teacher Preparation for Quality Teaching. *Journal of Teacher Education*, 62(4), 395-407. <https://doi.org/10.1177/0022487111409415>
- Hsieh, F. J., Law, C. K., & Shy, H. Y. (2011). Mathematics Teacher Education Quality in TEDS-M: Globalizing the Views of Future Teachers and Teacher Educators. *Journal of Teacher Education*, 62(2), 172-187. <https://doi.org/10.1177/0022487110390819>
- Kaptelinin, V. (1999). Learning Together: Educational Benefits and Prospects for Computer Support. *Journal of the Learning Sciences*, 8(3), 499-508. [https://doi.org/10.1207/s15327809jls0803&4\\_6](https://doi.org/10.1207/s15327809jls0803&4_6)
- Khan, M. S., Bibi, S., & Hasan, M. (2016). Australian Technical Teachers' Experience of Technology Integration in Teaching. *SAGE Open*, 6(3), 1-12. <https://doi.org/10.1177/2158244016663609>
- Khuziakhmetov, A. N., & Sytina, N. S. (2016). Educational Process Navigator as Means of Creation of Individual Educational Path of a Student. *International Journal of Environmental and Science Education*, 11(9), 2255-2264.
- Lebedeva, O., Bykova, S., Masalimova, A. R., Sokolova, N. L., & Kryukova, N. I. (2018). Peculiarities of developing high school students' lexical skills by means of the programmed learning technology. *XLinguae*, 11(1), 186-202. <https://doi.org/10.18355/XL.2018.11.01.16>



- Louie, B. Y., Drevdahl, D. J., Purdy, J. M., & Stackman, R. W. (2003). Advancing the Scholarship of Teaching through Collaborative Self-Study. *The Journal of Higher Education*, 74(2), 150-171. <https://doi.org/10.1080/00221546.2003.11777194>
- Mayer, R. E., & Moreno, R. (2003). Nine ways to reduce cognitive load in multimedia learning. *Educational psychologist*, 38(1), 43-52. [https://doi.org/10.1207/S15326985EP3801\\_6](https://doi.org/10.1207/S15326985EP3801_6)
- Nair, C. S., Webster, L., & Mertova, P. (2010). Leadership and Management of Quality in Higher Education. Oxford: Chandos Publishing. <https://doi.org/10.1533/9781780630373>
- Näykki, P., Järvenoja, H., Järvelä, S., & Kirschner, P. (2017). Monitoring makes a difference: quality and temporal variation in teacher education students' collaborative learning. *Scandinavian Journal of Educational Research*, 61(1), 31-46. <https://doi.org/10.1080/00313831.2015.1066440>
- Pange, J. (2004). How often do Pre-School Teachers in Greece Use Nt and ICT in Their Classrooms? A Study of Continuing Education Needs. *Journal of Adult and Continuing Education*, 10(1), 57-65. <https://doi.org/10.7227/JACE.10.1.6>
- Pyl, S. J. (1989). Diagnostic reports as bases for decisions on teaching. *Teaching and Teacher Education*, 5(1), 69-79. [https://doi.org/10.1016/0742-051X\(89\)90020-6](https://doi.org/10.1016/0742-051X(89)90020-6)
- Richards, C. E. (1988). A Typology of Educational Monitoring Systems. *Educational Evaluation and Policy Analysis*, 10(2), 106-116. <https://doi.org/10.3102/01623737010002106>
- Robertson, H. J. (2003). Teacher Education and Information and Communications Technology. *Journal of Teacher Education*, 54(4), 280-296. <https://doi.org/10.1177/0022487103255499>
- Rozhina, V.A., & Baklashova, T.A. (2018). Teaching English language to young school-age children while making projects, playing games and using robotics. *XLinguae*, 11(1), 102-113. <https://doi.org/10.18355/XL.2018.11.01.10>
- Schunk, D. H. (1982). Progress Self-Monitoring. Effects on Children's Self-Efficacy and Achievement. *The Journal of Experimental Education*, 51(2), 89-93. <https://doi.org/10.1080/00220973.1982.11011845>
- Seo, D., McGrane, J., & Taherbhai, H. (2015). The Role of Student Growth Percentiles in Monitoring Learning and Predicting Learning Outcomes. *Educational Assessment*, 20(2), 151-163. <https://doi.org/10.1080/10627197.2015.1028621>
- Shaffer, D. W., Nash, P., & Ruis, A. R. (2015). Technology and the New Professionalization of Teaching. *Teachers College Record*, 117(12), 1-30.
- Sorden, S. D. (2005). A cognitive approach to instructional design for multimedia learning. *Informing science journal*, 8, 263-279. <https://doi.org/10.28945/498>
- Tuninga, R. S., & Seinen, I. B. (1995). *The Supply and Demand of Distance Education in Russia*. Washington: The World Bank, Bureau Cross.
- Usova, A. V. (2002). How to Make Learning Interesting and Successful. *Russian Education & Society*, 44(2), 65-72. <https://doi.org/10.2753/RES1060-9393440265>
- Wang, J., Lin, E., Spalding, E., Klecka, C. L., & Odell, S. J. (2011). Quality Teaching and Teacher Education. *Journal of Teacher Education*, 62(4), 331-338. <https://doi.org/10.1177/0022487111409551>

<http://www.ejmste.com>



<http://www.ejmste.com>



<https://twitter.com/ejmste>



<https://www.facebook.com/ejmste>



<http://modestum.co.uk/>



[publications@modestum.co.uk](mailto:publications@modestum.co.uk)

## Promoting Education Equity in Rural and Underdeveloped Areas: Cases on Computer-Supported Collaborative Teaching in China

Harrison Hao Yang<sup>1,2\*</sup>, Sha Zhu<sup>3</sup>, Jason MacLeod<sup>1</sup>

<sup>1</sup> School of Educational Information Technology, Central China Normal University, Wuhan, CHINA

<sup>2</sup> State University of New York at Oswego, New York, USA

<sup>3</sup> Wuhan Huada National E-learning Technologies Co. Ltd., Wuhan, CHINA

Received 21 February 2018 • Accepted 25 March 2018

### ABSTRACT

In addition to the 37 million students attending rural schools, China operates ~67,000 one-teacher schools in remote and mountainous regions. Much research has concluded that these rural students are educationally disadvantaged in comparison to their urban peers, with impaction toward social stratification. Consequently, national policies have targeted such issues and begun implementing information and communication technology (ICT) initiatives to universalize the quality of educational services. However, it is well known that imbalanced or improperly utilized ICT resources may expand, rather than contract inequities. Therefore, our research examines two cases of uniquely large-scale educational ICT applications to showcase computer-supported collaborative teaching models with high potential from an equity perspective. Improved access in the quality of students' education and teachers' professional development opportunities among rural areas are the main benefits observed. Other developing countries with similar issues may replicate these technological approaches for balancing access to high quality educational opportunities.

**Keywords:** information and communication technology, collaborative teaching, rural-urban disparity, open online teaching units, remote synchronous classroom

### INTRODUCTION

Education equity<sup>1</sup> refers to fairness and justice in educational opportunity (Gillborn & Deborah, 1990). Much research has shown that inadequate educational opportunities have both negative individual and societal consequences (Buchmann & Hannum, 2001; Campos, Ren, & Petrick, 2016). Such consequences have led the United Nations' toward coordinating international remediation efforts that generate capacity for universal educational opportunity over the past 70 years (United Nations, 1941; UNESCO, 1990, 2000, 2015a). However, despite much progress, inequity within education persists. UNESCO (2015a) stated that, "policy has often been distanced from implementation" (p. 56). Therefore, the conceptualization and benchmarking of large-scale solutions that promote education equity remain in high demand throughout the world.

In China, the question of how education equity can be promoted also remains a critical issue. The initial discussion focused on inequity of circumstance between eastern and western development. However, rural disparity has more recently emerged in research as the most prominent factor driving inequity (Gan, Meng, & Xie, 2016; Golley & Kong, 2016; Hallinger & Liu, 2016; Li & Ranieri, 2013; Normile, 2017; Rao & Ye, 2016; Wang, Wang,

<sup>1</sup> Gillborn and Youdell (1990) further described education equity to include four aspects: (1) access, a complete lack of availability or explicit denial of education services due to some basis of identity; (2) circumstance, participation barriers in education systems due to inequalities of personal living situations; (3) treatment, typical daily interaction and processes of education systems that affect individuals differently; and (4) outcomes, the result of educational processes (pp. 2-3). This study emphasizes the circumstance aspect of education equity between rural and urban regions.

### Contribution of this paper to the literature

- Education equity is a critical global issue that is expected to be positively influenced by ICT applications; however, ICT policy is often cited as being distant from actual practice and no large-scale ICT solutions have been widely adopted as successful in balancing education equity.
- This paper reviews the extant literature of education equity in China and ICT-supported collaborative teaching approaches to add conceptual information and qualitative evaluation from an education equity perspective.
- Cases highlighting implementation of 'Open Online Teaching Units' and 'The Remote Synchronous Classroom' are presented and discussed to expedite adoption and direct future research on this topic.

Li, Li, 2017; Wu, 2013; Yang & Wan, 2015; Zhou et al., 2015), describing the issue as a more serious dilemma affecting both eastern and western regions of China.

The deployment of technology has become a key component in government mitigation efforts, because the integration of information and communication technology (ICT) can provide many benefits to education quality. For example, improving access, personalization, and flexibility for learning processes. However, when access or usage of ICT is unbalanced, as is seen among rural-urban Chinese settings (Li & Ranieri, 2013), the resulting digital divide can widen inequity in education. That is to say, appropriate ICT integration further improves the already higher standard of urban education conditions, while the inaccessible or underutilized ICT applications of rural areas may only maintain existing conditions. This notion of the digital divide has recently been highlighted as a critical issue reshaping the boundaries of universal accessibility research, which more commonly has focused on disparity issues affecting smaller fractions of people (Abascal, Barbosa, Nicolle, & Zaphiris, 2016). Therefore, in order to prevent worsening conditions of education equity, ensuring balanced access and utilization of educational resources is an issue of immediate importance. This research examines two cases of computer-supported collaborative teaching models to support governments in providing universal access to high quality educational resources.

## THEORETICAL FRAMEWORK

During the period of opening up and reform, China underwent a complete expansion in access to primary and secondary education. The *National Bureau of Statistics of China* shows that near universal enrollment in primary and secondary education systems was achieved in 2006; and the corresponding 'national average years of schooling' crossed the nine-year threshold in 2013. In recognition of universal enrollment, research indicates that the current status of education equity in China is most accurately explained by the effectively maintained inequality (EQI) hypothesis (Yang & Wan, 2015), which suggests that after a society achieves universal enrollment, inequity may continue to exist within the provision of differing qualities of education (Lucas, 2001). This theoretical perspective provides a foundation for the present study when examining the education equity-circumstantial quality-between rural and urban education systems.

## HISTORICAL REVIEW: EDUCATION EQUITY IN CHINA

The two primary mechanisms that affect education quality are intergenerational persistence and the provision of educational services (Golley & Kong, 2016). Intergenerational persistence describes the indirect factors that influence education quality, such as socioeconomic status and the relationship of family support for educational opportunity and attainment of their children (Hertz et al., 2007). The provision of educational services describes direct factors which influence education quality such as the human and technological resources of education systems.

### Intergenerational Persistence

Much research has explored intergenerational persistence in China and supported the notion that higher levels of parents' education typically correlate with greater educational attainment by their children (Golley & Kong, 2013). This is significant given that individuals' per capita disposable income and average years of schooling are both higher in urban areas<sup>2</sup>. Research has also suggested that modern family structures are changing differently, according to whether the setting is rural or urban (Normile, 2017; Wang, 2010). Due to the economic pull of

---

<sup>2</sup> National Bureau of Statistics of China 2015 data shows rural-urban per capita disposable income is ~11,000 to ~31,000, respectively. Meanwhile, 2010 data shows rural-urban average years of schooling of households is 7.6 to 10.5, respectively.

**Table 1.** Comparison of teachers with advanced degrees <sup>1</sup>

	2012	2013	2014	2015
Rural	78%	81%	83%	85%
Primary	77%	80%	84%	86%
Regular junior secondary	63%	66%	69%	73%
Regular senior secondary	95%	96%	96%	97%
Suburban	84%	86%	88%	89%
Primary	87%	91%	91%	93%
Regular junior secondary	68%	72%	75%	77%
Regular senior secondary	95%	96%	96%	97%
Urban	92%	93%	94%	95%
Primary	94%	95%	96%	97%
Regular junior secondary	84%	86%	88%	89%
Regular senior secondary	98%	98%	98%	98%

<sup>1</sup> Primary school teacher data describes the proportion of degrees above 3 years of college; Junior and senior secondary school teacher data describes the proportion of degrees above bachelors.

Source: Authors' calculation from *Educational Statistical Yearbook of China 2013-2016* data.

urbanization, China has experienced a complete shift of population composition and these migration trends<sup>3</sup> have reduced the number of nuclear families in rural areas, which in turn weakens the foundations for supporting educational success among rural students. Such factors of intergenerational persistence offer representative descriptions of rural disparity and should not be overlooked when discussing this topic. However, since intergenerational persistence is indirectly influential toward the quality of one's education, intergenerational persistence is not the primary focus of the study. Rather, the directly influential factors of educational services are the main focus of this study.

## Provision of Educational Services

The access to quality educational services can typically be described by two main factors of impact: (1) *human resources*, which primarily refers to teachers and (2) *technological resources*, which primarily describes the physical and digital learning content and tools that support educational processes. To describe the status of education equity, this section reviews the human and technological resources present in Chinese education.

### Human resources

Teacher and teaching quality can be assessed in several ways. The most common measures explore teachers' educational attainment, the organizational processes that shape teacher development, and the scope of teacher responsibilities which impact their teaching effectiveness. Analysis of 2016 data from the *Educational Statistics Yearbook of China*, published by the Ministry of Education of China, suggests equity of teacher quality based on the proportion of full-time teachers with advanced degrees, is less favorable among rural areas. As shown in **Table 1**, rural students are 11% less likely to have access to a teacher with an advanced degree after accounting for the number of students enrolled in each level of education. More specifically, the data show that rural junior secondary students have the weakest access to teacher quality, with only 73% of full-time teachers possessing advanced degrees.

The organizational processes of teacher training and collaboration are also important factors that influence education equity between rural and urban regions. Hallinger and Liu (2016) suggested that organizational processes of school leadership and teacher learning are important to sustaining students' performance improvement. By examining teachers in both urban and rural settings, findings identified significantly less on-the-job learning among the rural teachers, which indicated that the engagement of school-level processes may result in different patterns of growth that increase inequity overtime (Hallinger & Liu, 2016).

This notion of organizational processes being critical to instructional capacity was also examined. The results showed rural-urban inequity in relation to Teaching and Research Groups (TRG), whereby rural TRG processes were found to be less engaging and rigorous (Wang et al., 2017). Critical educational processes such as peer class observation, collective lesson planning, and novice teacher mentorship programs were found to be much less frequent among rural schools. To supplement this comparison with western research on teacher learning, research analyzed more than one million student-year observations over a ten-year time period in the USA and identified a variety of educational influences (Jackson & Bruegmann, 2009). For example, first year teachers were seen as being

<sup>3</sup> The National Bureau of Statistics of China shows the demographic composition of the population has shifted from ~83% rural residency in 1975 to ~44% rural residency in 2015.

detrimental to student learning, meanwhile, having a collaborative network of teachers with more than one year of teaching experience was significantly positive. Additionally, students showed greater achievement gains in mathematics and reading when their teachers were involved with colleague observations and on-the-job learning (Jackson & Bruegmann, 2009). In essence, the results suggested that even ineffective or underqualified teachers were malleable and teaching quality was better when teachers' peers were stronger. Therefore, organizational processes are well recognized as being beneficial for education quality regardless of individual teacher qualifications, and such processes have been identified as weaker within the rural education settings of China.

The scope of teacher responsibilities may contribute even more significantly to disparities in rural Chinese education systems. An example is the many rural one-teacher schools, where a single individual is required to address all course subjects in a multi-grade teaching capacity. In these settings the teacher must assume all roles and responsibilities for managing the school, such as cooking, cleaning, and maintaining the facilities, with only a minimal level of infrastructural support and typically an inadequate level of educational training. Such conditions constitute the most severe cases of education inequity, particularly within specialized academic disciplines that are often unfamiliar to the teachers (e.g. music, art, foreign languages). While the exact number of remaining one-teacher schools has not been officially reported in the wake of the Rural School Mapping Adjustment<sup>4</sup>, which has greatly consolidated the number of rural schools over the past decade, recent literature suggests that as many as 67,000 one-teacher schools exist in rural areas of China (Zhang, Yang, Fan, & Huang, 2015). In these settings, the level of teacher qualifications, the capacity of teachers to teach specialized subjects, the minimal influence of peer networks on teacher learning, and the inadequate amount of time for lesson preparation make education quality difficult to achieve.

In summary, the relevant literature strongly describes a human resource disparity among rural educational settings, whereby there are not enough qualified teachers. In addition, research suggests that without processes to balance teacher quality between rural and urban settings, education equity may worsen over time.

### *Technological resources*

Technological resource inequity can result in *digital divide*, which refers to ICT usage that expands education inequity due to the developmental advantage provided by ICT being used in an imbalanced way (Van Dijk, 2005). Research suggests that digital divide involves two layers: first-level issues (e.g., resulting from the shortage of resource availability) and second-level issues (e.g., resulting from the difference in resource usage) (Hargittai, 2002). That is to say, the most common measures of technological resources relate to the degree of resource access and the capabilities or procedure of resource integration.

In alignment with UNESCO's (2015a) recommendation for ICT policies to focus on integration that *serves* rather than *drives* strategic advantage in education (p. 56), national initiatives have made considerable advances in balancing access and developing the capability to connect educational resources between urban and rural settings. For example, since 2000, a series of *Modern Distance Education (MDE) Projects* (Wang & Li, 2010; Ying, 2007) directed over 11 billion yuan toward educational ICT initiatives, which included the investment in over 440,000 DVD players, 41,000 computer labs, and 275,000 satellite receivers for establishing school internet access throughout China. In addition, the MDE Projects and several others, such as the *National Program for Rural Teachers through Summer Vacation* (Shi, 2007), began training teachers to use the newly provided technological resources, as well as compiling a digital archive of high quality teaching resources that is freely available for integration in any location. These national initiatives all have been driven by a vision to balance education quality between regions and have greatly contributed to balancing the first layer of digital divide, technological resource access.

To illustrate national development over the past decade, regional exploration of technological resources shows that the current status of infrastructure supporting schools' internet access is near complete. **Table 2** shows that the proportion of schools without internet access is greater among rural areas (11%) as compared to urban areas (3%), which equates to 6% and 1% of total schools without internet, respectively. While illustrating rural disparity, this data suggests that the capacity to share resources between schools is now available for the majority of disadvantaged students inhabiting rural areas of China.

---

<sup>4</sup> A comparison of 2003 and 2015 *Educational Statistical Yearbook of China* data shows the total number of rural primary and secondary schools have been reduced by 241,985 and 21,000, respectively.



**Table 2.** Distribution of internet connectivity, by region

	Student enrollment <sup>1</sup>	Total schools		Schools without internet access	
	(national %)	(1000s)	(%)	(regional %)	(national %)
Rural	23	~136 <sup>2</sup>	53	11	6
Suburban	43	~76	30	5	1
Urban	34	~44	17	3	1
Total	100	~256	100	-----	8

<sup>1</sup> Total student enrollment = 163,785,323; Includes primary and regular secondary schools

<sup>2</sup> Excludes the total number of one-teacher schools, which is estimated at greater than 67,000 schools.

Source: 2015 data from the *Educational Statistical Yearbook of China*.

**Table 3.** National Distribution of ICT resources, by region

	Computers (%)	Computers used for instruction (%)	Tablets (%)	Networked multimedia classrooms (%)
Rural	20	20	15	20
Suburban	37	38	31	40
Urban	43	42	54	40
Total	100	100	100	100

Source: Authors' calculation from 2016 data in the *Educational Statistical Yearbook of China*.

Further analyses of technological resources show similar access patterns with an urban-skewed distribution. **Table 3** shows that the rural-urban distribution of resources is relative to the percentage of the total population inhabiting each area. However, when considering that the percentage of rural student enrollment is spread across greater than three times more schools than urban student enrollment (as shown in **Table 2**), it is clear that rural students have much weaker access to technological resources for learning. It is also worth noting that these statistics do not consider the students attending the greater than 67,000 one-teacher schools, which are conceptually the most disadvantaged from this perspective.

The use of technological resources is a separate and more serious issue in China. Li and Ranieri (2013) showed that regardless of the type of internet usage (e.g., personal or academic), urban children used the internet more frequently than rural children. Additionally, Li and Ranieri's study showed that students of rural and migrant schools displayed lower scores on all levels of internet inequality indicators (digital access, autonomy of use, social support, internet use, and self-efficacy) than their urban counterparts. Similarly, basic computer awareness and literacy education is more common in urban, as opposed to rural areas (Yang et al., 2013). Therefore, rural students are not only disadvantaged in access, but also by the process of technological resource integration in China when compared to students inhabiting urban areas.

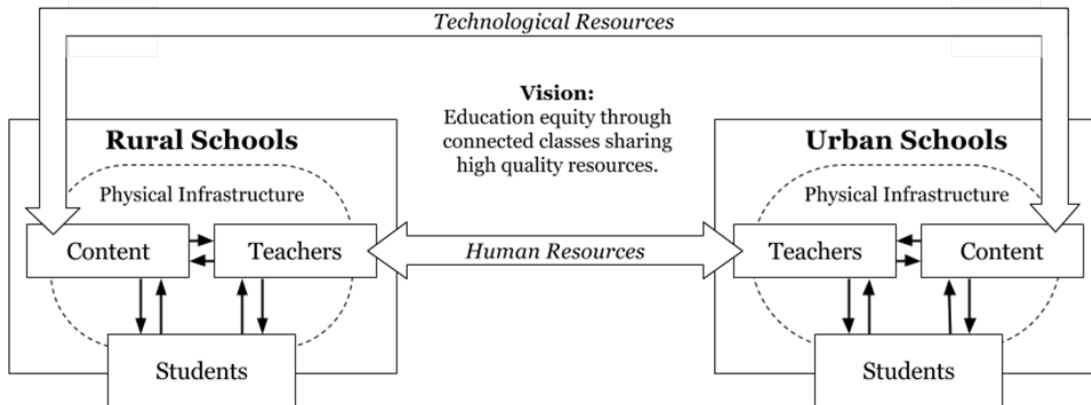
### Summary of educational resources

To synthesize the related topics of human and technological resources in education, research suggests that rural students are disadvantaged in comparison to urban students in many ways. However, the most serious threat to education equity seems not to be the basic access to technological resources, because the statistics show high percentages of school internet connectivity in all areas. Rather, the human factors of teaching quality and technological utilization are the issues. Furthermore, teaching quality and technology utilization are also issues that are more complicated to resolve. If such problems are not addressed, education equity between rural and urban students is very likely to worsen rather than improve, as a result of educational ICT and the digital divide.

## CASE EXAMINATIONS: COMPUTER-SUPPORTED COLLABORATIVE TEACHING MODELS

The overarching goal of ICT mitigation strategies in China has been to leverage capacity for sharing human and technological resources to improve education quality among disadvantaged students in rural areas<sup>5</sup>. The main factor that sets China's implementation strategy apart from other exemplary projects (e.g., South African Department of Education, 2004; UNESCO, 2015b) is the scope of initiatives. To our knowledge, China is the first large nation to implement an ICT strategy that attempts to standardize quality across the entire country. **Figure 1** illustrates the direction of this national ICT strategy connecting rural and urban regions. Of the various strategies that exist for sharing resources through ICT, two computer-supported collaborative teaching approaches (Yang,

<sup>5</sup> 2016 data from the *Educational Statistical Yearbook of China* reports greater than 37 million students are enrolled in rural education which was the equivalent of ~23% of total student enrollment within primary, regular junior secondary, and regular senior secondary education levels.



**Figure 1.** Direction of unique nation-wide educational ICT strategy in China

Zhu, & MacLeod, 2016) have been showcased in China to provide the greatest potential: (1) *the on-site leadership model*, in which an underqualified teacher indirectly connects with an experienced teacher through ICT to improve their personal teaching quality for students; (2) *the off-site leadership model*, in which an underqualified teacher directly connects with an experienced teacher for on-the-job training while the off-site experienced teacher improves teaching quality for students in the disadvantaged area. In both situations, computer-supported collaborative teaching refocuses the traditional purpose of ICT integration from personalizing learning processes for individuals to improving learning quality for large populations. This section describes a case for each of the two approaches (on-site and off-site leadership models) based on real scenarios from an education equity perspective.

### Case 1: The On-site Leadership Model

#### Overview

The on-site leadership model represents a computer-supported collaborative teaching approach where the on-site teacher of a rural disadvantaged school facilitates the educational process for students through a combination of traditional and digital content delivery (Yang et al., 2016). By integrating high quality technological resources (e.g., pre-recorded instructional videos) provided by experienced off-site teachers, on-site rural teachers are able to customize instruction for rural students. In this model, the off-site teacher is only an asynchronous instructional figure. Furthermore, there is typically no direct communication between on-site and off-site teachers in this model.

#### Open online teaching units

Open online teaching units are freely accessible educational lessons that can provide formal ICT-supported instruction (e.g., Coursera, n.d.; Kahn Academy, n.d.) and represent a case for describing the on-site leadership model. In China, a massive archive or open online teaching units have been universally provided as a result of educational ICT initiatives and the off-site leadership model teaching approach began gaining popularity in 2014, due to the implementation of the *One Teacher One Lesson Program*<sup>6</sup> (National Center for Educational Technology, 2017a). As part of this program, experienced teachers throughout China have recorded the instructional delivery of their best classroom lesson. Recordings are then reviewed for quality, archived, and openly shared via the National Public Service Platform for Educational Resources (National Platform) (National Center for Educational Technology, 2017b).

As of June 2017, greater than 7,000,000 lessons have been shared on the National Platform, including instructional delivery of lessons for 21 primary school subjects, 26 junior secondary school subjects, and 24 senior secondary subjects (National Center for Educational Technology, 2017a). On-site teachers in disadvantaged areas may now search and select from a huge database of high quality lessons to integrate into their classroom in ways that compliment or replace their traditional instruction for the purpose of improving quality.

<sup>6</sup> This name is translated from the Chinese title “一师一优课、一课一名师.”

## *Examining the effects*

### *Universalizing access to experienced teachers*

As a result of open online teaching units, rural students are digitally connected to the best instructional delivery of experienced teachers working within the qualifications of their educational specialization. That is to say, educational ICT is providing conditions for teaching quality to become location independent. From an education equity perspective, this computer-supported collaborative teaching approach is the most advantageous in the disadvantaged environments of one-teacher schools. In these disadvantaged areas, teachers' time and qualifications are serious issues (Zhang et al., 2015). To manage a multi-grade classroom, teachers choose between two less than ideal options. They can divide their time between individual students, which leaves young students partially without teacher direction, or, they can simultaneously teach students with vastly differing academic proficiencies, which provides sub-optimum learning opportunities. Open online teaching units have supported a shift in teachers' roles from class lecturer to side-by-side student learning facilitator (Yang et al., 2016). In this case, the teachers' lesson planning and delivery time can be redirected toward 1:1 student-to-teacher interaction, which offers more customized educational opportunities to students. In addition, it allows teachers to account for the individual differences and academic proficiencies of their students. These factors greatly improve the access to quality education among rural students.

### *Universalizing access for teacher development*

Open online teaching units are supporting the growth of teachers working in rural areas. As a result of remarkable rural-urban population differences (Ministry of Education, 2016; National Bureau of Statistics of China, 2016), rural teachers simply operated in circumstances with smaller peer support networks. However, open online teaching units have provided vast access for new asynchronous forms peer observation, which can expand their content and pedagogical knowledge. Through self-reflection over time, this emerging process supports the growth of rural teachers in ways that will continuously raise the quality of rural teaching capabilities.

### *Improving teacher interest for ICT integration*

The development and sharing of open online teaching units has vastly increased teachers' perceived usefulness of ICT integration in the classroom. The second layer of digital divide is a human-derived problem (Abascal et al., 2016; Hargittai, 2002). That is to say, it is caused by the improper use or neglect of available ICT. After technological resources are accessible, the only way to narrow the second level of digital divide is to increase technological awareness, encourage technology acceptance, and then provide training to develop teachers' digital literacies and technical pedagogical content knowledge. Simply providing technology is not enough to solve the digital divide that is creating inequity between rural and urban students. Instead, the how technology is used, and how can teachers be convinced that there is value in using technology for teaching purposes are the critical issues. Thus, initiatives perceived as very useful, such as open online teaching units through the on-site leadership approach, offer much opportunity for motivating the proper forms of ICT integration in education.

## **Case 2: The Off-site Leadership Model**

### *Overview*

The off-site leadership model represents a computer-supported collaborative teaching approach in which an experienced off-site teacher, usually from an urban area, assumes an interactive leadership role in the instructional process of a disadvantaged rural school (Yang et al., 2016). In this approach, the experienced off-site teacher is fully responsible for choosing learning content, organizing the course schedule, and delivering instruction to students via one-way or two-way teleconferencing technology. The less experienced on-site teacher contributes in a supportive role that primarily assists with the organization and maintenance of students in the remotely connected rural class. Unlike the on-site leadership model, where no direct communication exists between teachers, the off-site leadership model requires regular communication between teachers throughout the duration of the course. For example, to account for geographic separation, the rural teacher must communicate student progress to the more experienced urban teacher. Meanwhile, the urban teachers provide mentorship to the less experienced rural teachers to ensure their continued professional development.

### *The Remote Synchronous Classroom (RST)*

The RSC refers to the connection of geographically distant classrooms through ICT for parallel instructional delivery of lessons to multiple locations simultaneously. The RSC provides an example for describing the off-site leadership model and has largely become possible to support education equity due to nation-wide educational ICT initiatives. The deficit of teaching capabilities in rural areas for specialized subjects like art, music, and English, has contributed to RSC's popularity.

The most common form of RSC connects instructional delivery between two classes. However, the RSC has been documented in some cases to connect greater than two classes at once. From an education equity perspective, the RSC has primarily been used under three sets of conditions: (1) the complete RSC, where everything is shared between classes (e.g., Yang, 2014); (2) the partial RSC, where only instruction is shared between classes (e.g., Audio-visual Station of Enshi, 2013); (3) the exclusive RSC, where instruction is remotely delivered to only the disadvantaged group(s) of students (e.g., Song Education, 2015).

The cities of Enshi in Hubei Province and Xian'an in Shanxi Province provide a good opportunity to showcase the emerging use of RSC for education equity in China. In Enshi, there are 655 primary and secondary schools, including 569 rural schools and 526 one-teacher schools. To date, 22 urban schools and 22 one-teacher schools have teamed together and built remote synchronous classrooms (Yang, 2016). In Xian'an, there are 128 primary and secondary schools, including 28 one-teacher schools. Over the past three years, Xian'an has established seven experimental groups of collaborative teaching communities, which have benefited over 600 students and 40 teachers in 31 rural schools (Liao, Cheng, & Wu, 2017). In the following section, real examples of RSC usage are described from Enshi and Xian'an. Examples of the complete RSC and partial RSC will be illustrated from Enshi data, while the exclusive RSC will be illustrated from Xian'an data.

### *Examining the effects*

#### *Universalizing access for curriculum offerings*

A primary benefit of implementing the off-site leadership model is the capabilities it provides to expand curriculum offerings in rural areas, as is particularly in high demand among many one-teacher schools (Zhang et al., 2015). In situations where teachers are unqualified or underqualified to teach courses, students' learning suffers. In the worst scenarios, courses may simply be omitted from students' academic schedules due to the lack of specialized knowledge necessary for instruction. This is not only an issue of education equity, but in some cases also a national policy violation (cf. State Council of the People's Republic of China, 2017). National policy mandates the training of students in Chinese, mathematics, art, music, and ideological and moral subjects starting in first grade. However, many specialized subjects such as music and the arts tend to be overlooked without implementation of technological solutions like the RSC.

To illustrate the depth of the RSC in supporting curriculum expansion, Mr. Hu, a teacher in Mao Batang Primary School, which is a one-teacher school located in a rural area of Enshi stated, "I have not studied English or music, so it is difficult for me to deliver the content of these courses to my students. However, with the help of the remote synchronous classroom, my students can now learn from [other] teachers when studying outside of my specialization" (China Education News, 2015). In addition, a student representative of the Caiqiao One-teacher School in Xian'an, stated that, "Since the RSC has become available, I can now study art and music classes. I think the content of the RSC classes are very rich, and I like them very much" (Xiong, 2016). Both of these testimonials describe a situation where the availability of curriculum has been expanded for students of rural areas, providing a positive force toward universalizing education quality. That is to say, the RSC has improved the quality of rural instruction through (1) connecting rural students with more experienced urban teachers, as well as (2) balancing basic opportunities to learn the same array of curriculum that is a well-recognized standard in urban areas.

#### *Universalizing access for teacher development*

The RSC provides considerable advantages for addressing the issue of less engaging school-level processes contributing toward the growth of inequity between regions over time (Hallinger & Liu, 2016). Prior to the RST, organizational processes and on-the-job training of rural schools was suggested as less engaging and rigorous (Wang et al., 2017). This phenomenon may be explained by population influence, which is significantly less dense among rural areas. That is to say, organizational structures with less teachers relate to less mentorship, collaboration, and competition. However, through the introduction of an experienced off-site teacher through the RST, rural teachers now have new opportunities to experience critical educational processes such as peer class observation and novice teacher mentorship, which are processes shown to positively influence student achievement (Jackson & Bruegmann, 2009).

#### *Forming student-to-student intercultural connection*

The RSC is increasing the level of engagement and widening the perspective of student thinking in the classroom. To describe this effect, a student representative from a one-teacher school in Hupo stated, "Although I could only see the teacher on the screen, she taught us dancing and interesting songs. The music class was more interesting than ever before" (Gong, 2015). Furthermore, a representative student from the Cuiba Town Primary School of Enshi said:

This kind of class is like a video chat and it lets me feel the power of education information technology. I think that the RSC is interesting and challenging. Students of two classes are now learning at the same time, so we could

**Table 4.** Technical implementation criteria

Description	On-site leadership	Off-site leadership
Collaboration type	Asynchronous	Synchronous
Visual/audio components	√	√
Teleconferencing components		√
High-speed internet	Intermittent is okay	Stable and required

learn from each other, and compete with each other, which really inspires our interests for learning (People's Daily Online, 2016).

In addition, Mr. Liu, the director of the one-teacher school, reported that "through the RSC, students in Hupo One-teacher School have widened their horizon, which has caused them to become more active. The RSC has opened a wonderful door for the students, and let the outside world into our school" (Gong, 2015). Both of these representative quotes illustrate the depth of opportunity for increasing engagement that can be offered through the RSC. This is critical for balancing education equity because regardless of education quality, the perspective of students from areas of different populations varies greatly. Opportunities like this, to learn under conditions that widen the vantage point for understanding, both in rural and urban settings, are critical for improving the quality and balance of education equity in China.

#### *Stimulating a trend of reverse migration*

The several decade trend of decreases in rural school enrollment is not only due to economically driven migration (e.g., National Bureau of Statistics of China, 2016; Wu, 2013), but also largely influenced by the known differenced in education quality between rural and urban regions (Gu, 2016; Li & Ranieri, 2013). In recognizing that ICT can impart educational quality that is universal, many migrant families are now opting to return their children to the schools in their home residency. To describe this phenomenon of reverse migration, Mrs. Wang stated:

The hardware facilities in our village school are not bad in comparison to urban schools. In addition, the village school is near home and convenient. After careful consideration, the whole family agreed to let my child return to the village school (Ke & Chen, 2016).

In this scenario, Mrs. Wang has described how national ICT initiatives have elevated the quality of learning conditions in rural schools. This is particularly true within the one-teacher school in the Xiangzhou district of Xiangyang to which her child reverse-migrated (Ke & Chen, 2016). The Wang family's decision to allow their child's reverse migration is not unique. In fact, it has been reported that the student enrollment of 23 out of 25 one-teacher schools in Xian'an have increased from 352 to 481 students between the fall of 2014 and the spring of 2016 (Cen, 2016). This snapshot of reverse migration represents a notable turning point for education equity, as to the best of our knowledge, this is among the first evidences suggesting migration toward rural areas in several decades.

### **Discussion of Implementation Criteria and Strategies**

To synthesize the two computer-supported collaborative teaching approaches (Yang et al., 2016), a comparison of the required implementation criteria, as well as a proposal of implementation strategy are discussed. As seen in **Table 4**, the main difference between the two models is the synchronous versus asynchronous nature of collaboration. Both models require some type of audiovisual ICT components. However, the synchronous nature of the off-site leadership model also requires more advanced teleconferencing components and stable high-speed internet in order to be effective. Due to this, the on-site leadership model is best in situations where technological infrastructure is limited and may not yet be capable of delivering smooth synchronous computer-mediated communication. The off-site leadership model should be employed only where the reliability of technological infrastructure is capable of supporting effective collaboration.

From the perspective of education equity, each computer-supported collaborative teaching approach should be strategically used to maximize desired benefits. As shown in **Table 5**, the on-site leadership model should be used to improve provisional quality where teachers are unqualified to teach a class, or constrained by time in multigrade teaching environments. This model does not provide a dynamic professional development opportunity for the teacher. However, the on-site leadership model does provide opportunities for rural teachers to observe high quality peer teaching. In addition, the on-site leadership model can be implemented very quickly and used for long durations to address the lack of quality curriculum, lack of teacher time, or lack of appropriate curriculum that matches students' individual academic proficiencies.

**Table 5.** Recommended implementation strategy

<b>Description</b>	<b>On-site leadership</b>	<b>Off-site leadership</b>
Implementation speed	Fast	Slow
Duration of use	Long term	Medium term
Teacher workload	Increases efficiency	Maintains schedule
Professional development	Low quality	High quality
Teacher type	Unqualified teacher	Developing teacher
Type of quality improvement	To account for weakness	To expedite mastery

Conversely, the off-site leadership model should be used to balance access to quality instruction of specialized subjects. In addition, the off-site leadership model should be used to provide high quality and dynamic teacher mentorship opportunities for less experienced teachers. With this model, the implementation time period should be longer, as organizational arrangements are required for implementation, and teacher mentorship should not be a one-time experience. However, the duration of off-site leadership model implementation should not be permanent, as on-site teachers are learning from an off-site teacher with the intent to independently manage the class after their skills improved.

In summary, both computer-supported collaborative teaching approaches leverage the capacity of nation-wide educational ICT initiatives to balance education equity by universalizing the quality opportunities for disadvantaged rural students and teachers. The main difference between the two approaches is that the off-site leadership model provides more dynamic instructional delivery (for students) and professional development (for teachers). In contrast, the on-site leadership model provides greater opportunities for increasing the efficiency of rural teachers. Due to the mentorship component of the off-site leadership model, workload efficiency should not be expected to increase. However, that is because the teachers' developmental opportunities can be more personalized and beneficial.

## CONCLUSION

Education equity is one of this century's most significant problems (UNESCO, 1990, 2000, 2015a), although there are currently no effective large-scale solutions. Particularly in China, the rapid pace of social transformation has created rural vulnerabilities in education which remain an important but unsolved challenge. However, this challenge brings opportunity. The study presented here highlights innovations in Chinese primary and secondary education which emerged through nation-wide educational ICT initiatives over the past decade.

By reviewing the human and technological resources of the compulsory nine-year education system, this study supports the EQI hypothesis (Lucas, 2001; Yang & Wan, 2015) and its theoretical justification of inequality post-universal enrollment of students in education, as rural students continue to appear disadvantaged by circumstance. This is particularly true in relation to teachers' educational attainment (Ministry of Education, 2016), the organizational processes that shape teacher development (Hallinger & Liu, 2016; Wang et al., 2017), and the scope of teacher responsibilities which impact their teaching effectiveness (Zhang et al., 2015). When considering all of the remote one-teacher schools, more than 200,000 schools are critically affected by all of these issues in rural and underdeveloped areas. However, educational ICT offers great potential for remedying this dilemma. The issue of a digital divide (Hargittai, 2002; Van Dijk, 2005) now appears to be less related to access, and more related to utilization. Therefore, much emphasis should be placed on teacher training and assessment of ICT integration, to support more appropriate utilization of ICT resources in rural areas. Our examination of two cases suggests that computer-supported collaborative teaching (Yang et al., 2016) is a positive method for beginning addressing this issue.

By examining two cases that highlight collaborative teaching in China, this study assesses the large-scale potential of policies for national ICT implementation in addressing matters of education equity. Open online teaching units provide a representative example of how the on-site leadership model is being implemented. Strategically, this model should be used to address curriculum deficits for long term durations, particularly in situations where teachers are unqualified, implementation must be fast, or technological infrastructure may still be developing. In contrast, the RSC offers a representative example of how the off-site leadership model is being implemented. This model is conceptually similar to the on-site leadership model. However, the synchronous nature offers a more dynamic student learning experience and supports a higher quality professional development opportunity. In either case, collaborative teaching provides opportunities to universalize access to quality education for students and teachers in rural and underdeveloped areas.

Education equity (Gillborn & Deborah, 1990) is a complex social issue that requires multifaceted attention. It is important to note that this study qualitatively described the most promising opportunities of educational ICT utilization in China from an equity perspective at the primary and secondary level of education. Much additional



research is needed to further explore the specific pedagogy of these computer-supported collaborative teaching approaches, as well as to develop professional training strategies, and assess the real impact of collaborative teaching on student learning. In addition, future research should explore student and teacher perceptions of these approaches to guide the improvement of teaching and learning effectiveness.

To conclude, much research and policy, particularly that of the United National Sustainable Development Goals, have recognized education equity as a critical global issue and noted the lack of large-scale ICT solutions to support the execution of policy agendas. The same applies to China; however, the large population, mountainous geography, and fast-paced rate of economic development has made the issue much more prominent. Computer-supported collaborative teaching models emerged in China as a nation-wide innovation that offers large-scale potential for promoting education equity (Yang et al., 2016). To our knowledge, few nations have attempted such an approach at this scale. All efforts to refine understanding of such approaches are likely to strengthen educational benefits and increase teachers' acceptance of education modernization in China and throughout the world.

## REFERENCES

- Abascal, J., Barbosa, S. D. J., Nicolle, C., & Zaphiris, P. (2016). Rethinking universal accessibility: a broader approach considering the digital gap. *Universal Access in the Information Society*, 15(2), 179–182. <https://doi.org/10.1007/s10209-015-0416-1>
- Audio-visual Station of Enshi (2013, December 19). Enshi seizes opportunities to actively promote education informatization [In Chinese]. Retrieved from <http://www.caigou.com.cn/news/20131219135.shtml>
- Buchmann, C., & Hannum, E. (2001). Education and stratification in developing countries: A review of theories and research. *Annual Review of Sociology* 27, 77–102. <https://doi.org/10.1146/annurev.soc.27.1.77>
- Campos, B.C., Ren, Y., & Petrick, M. (2016). The impacts of education on income inequality between ethnic minorities and Han in China. *China Economic Review*, 41, 253–267. <https://doi.org/10.1016/j.chieco.2016.10.007>
- Cen, Y. (2016, April 15). The causes of reverse migration in one-teacher school of Xian'an [In Chinese]. Retrieved from <http://news.cnu.edu.cn/shendu/tebiebaodao/2016/0309/15127.html>
- China Education News (2015, March 24). Teaching challenges of synchronous classroom in Enshi [In Chinese]. Retrieved from <http://www.eduyun.cn/ns/njyxxhzixundongtai/20150324/22649.html>
- Coursera. (n.d.). Retrieved from <https://www.coursera.org/>
- Gan, Y., Meng, L., & Xie, J. (2016). Comparison of school readiness between rural and urban Chinese preschool children. *Social Behavior and Personality*, 44(9), 1429–1442. <https://doi.org/10.2224/sbp.2016.44.9.1429>
- Gillborn, D., & Deborah, Y. (1990). *Rationing education: Policy, practice, reform, and equity*. UK: McGraw-Hill Education.
- Golley, J., & Kong, S. T. (2013). Inequality in intergenerational mobility of education in China. *China & World Economy*, 21(2), 15–37. <https://doi.org/10.1111/j.1749-124X.2013.12013.x>
- Golley, J., & Kong, S. T. (2016). Inequity of opportunity in China's educational outcomes. *China Economic Review*. <https://doi.org/10.1016/j.chieco.2016.07.002>
- Gong, Y. (2015, May 16). Cloud platform enable to students of one-teacher school to enjoy high quality class [In Chinese]. *Huizhou Daily*.
- Gu, Y. (2016, March 9). Analyzing the perspective of rural teaching [In Chinese]. Retrieved from [http://www.sohu.com/a/62604265\\_176210](http://www.sohu.com/a/62604265_176210)
- Hallinger, P., & Liu, S. (2016). Leadership and teacher learning in urban and rural schools in China: Meeting the dual challenges of equity and effectiveness. *International Journal of Educational Development*, 51, 163–173. <https://doi.org/10.1016/j.ijedudev.2016.10.001>
- Hargittai, E. (2002). Second-level digital divide: Differences in people's online skills. *First Monday*, 7(4), e19.
- Hertz, T., Jayasundera, T., Piraino, P., Selcuk, S., Smith, N., & Verashchagina, A. (2007). The inheritance of educational inequality: International comparisons and fifty year trends. *The B.E. Journal of Economic Analysis and Policy*, 7(2), 1–46. <https://doi.org/10.2202/1935-1682.1775>
- Jackson, C.K., & Bruegmann, E. (2009). Teaching students and teaching each other: the importance of peer learning for teachers. *American Economic Journal: Applied Economics*, 1(4), 85–108. <https://doi.org/10.1257/app.1.4.85>
- Kahn Academy. (n.d.). Retrieved from <https://www.khanacademy.org/>
- Ke, J., & Chen, M. (2016, June 20). Education transformation on 'nerve endings'. *China Education Daily*. In Chinese.

- Li, Y., & Ranieri, M. (2013). Educational and social correlates of the digital divide for rural and urban children: A study on primary school students in a provincial city of China. *Computers & Education*, 60(1), 197-209. <https://doi.org/10.1016/j.compedu.2012.08.001>
- Liao, W., Cheng, Y., & Wu, Q. (2017). Strategies and approaches for the construction of network schools in rural one-teacher schools: taking Xian'an Digital School construction as an example [In Chinese]. *China Educational Technology & Equipment*, 1, 41-42. <https://doi.org/10.3969/j.issn.1671-489X.2017.01.041>
- Lucas, S. R. (2001). Effectively maintained inequality: Education transitions, track mobility, and social background effect. *American Journal of Sociology*, 106, 611-60. <https://doi.org/10.1086/321300>
- Ministry of Education. (2004-2016). *Educational Statistical Yearbook of China* [In Chinese].
- National Bureau of Statistics of China. (2009-2016). *China Statistical Yearbook*. Retrieved from <http://www.stats.gov.cn/enGLiSH/>
- National Center for Educational Technology. (2017a). One teacher one lesson program. Retrieved from <http://1s1k.eduyun.cn/portal/html/1s1k/index/1.html>
- National Center for Educational Technology. (2017b). National Public Service Platform for Educational Resources. Retrieved from <http://www.eduyun.cn/>
- Normile, D. (2017). China's childhood experiment. *Science*, 357(3657), 1226-1230. <https://doi.org/10.1126/science.357.6357.1226>
- People's Daily Online - Hubei Channel (2016, April 28). Remote synchronous classroom in a primary school of Enshi [In Chinese]. Retrieved from <http://www.ceiea.com/html/201603/201603281118487818.shtml>
- Rao, J., & Ye, J. (2016). From a virtuous cycle of rural-urban education to urban-oriented rural basic education in China: An explanation of the failure of China's rural school mapping adjustment policy. *Journal of Rural Studies*, 47, 601-611. <https://doi.org/10.1016/j.jrurstud.2016.07.005>
- Shi, B. (2007). Review of National Training Plan for Rural Teachers in summer vocation [In Chinese]. *Primary and Secondary Teacher Training*, 10, 5-7. <https://doi.org/10.3969/j.issn.1005-1058.2007.10.002>
- Song Education. (2015, November 24). The 1-to-2 synchronized class approach helping the city of Xian'an deliver quality [In Chinese]. Retrieved from [http://www.sohu.com/a/43863901\\_284516](http://www.sohu.com/a/43863901_284516)
- South African Department of Education. (2004). White paper on e-education: Transforming learning and teaching through information and computer technologies (ICTs). Retrieved from <https://www.education.gov.za/Portals/0/Documents/Legislation/White%20paper/DoE%20White%20Paper%207.pdf?ver=2008-03-05-111708-000>
- State Council of the People's Republic of China (2017, Sept). Govt releases guidelines to lower school dropout rates. Retrieved from [http://english.gov.cn/policies/latest\\_releases/2017/09/05/content\\_281475838269118.htm](http://english.gov.cn/policies/latest_releases/2017/09/05/content_281475838269118.htm)
- UNESCO. (1990). *World declaration on education for all*. New York, NY: UNESCO Publishing. Retrieved from [http://www.unesco.org/education/pdf/JOMTIE\\_E.PDF](http://www.unesco.org/education/pdf/JOMTIE_E.PDF)
- UNESCO. (2000). *The Dakar framework for action: Education for all meeting our collective commitments*. Paris, France: UNESCO Publishing. Retrieved from <http://unesdoc.unesco.org/images/0012/001211/121147e.pdf>
- UNESCO. (2015a). *The EFA global monitoring report 2015. Education for all 2000-2015: Achievements and challenges*. Paris, France: UNESCO Publishing. Retrieved from <http://unesdoc.unesco.org/images/0023/002322/232205e.pdf>
- UNESCO. (2015b). Digital services for education in Africa. Retrieved from <http://unesdoc.unesco.org/images/0023/002318/231867e.pdf>
- United Nations (1941). Universal Declaration of Human Rights. Retrieved from [http://www.ohchr.org/EN/UDHR/Documents/UDHR\\_Translations/eng.pdf](http://www.ohchr.org/EN/UDHR/Documents/UDHR_Translations/eng.pdf)
- Van Dijk, J. A. G. M. (2005). *The deepening divide: Inequality in the information society*. Thousand Oaks, CA: Sage Publications. <https://doi.org/10.4135/9781452229812>
- Wang, D., Wang, J., Li, H., & Li, L. (2017). School context and instructional capacity: A comparative study of professional learning communities in rural and urban schools in China. *International Journal of Educational Development*, 52, 1-9. <https://doi.org/10.1016/j.ijedudev.2016.10.009>
- Wang, Y. (2010). An analysis of changes in Chinese family structure between urban and rural areas: On the basis of the 2010 national census data. *Social Sciences in China*, 35(4), 100-116. <https://doi.org/10.1080/02529203.2014.968349>
- Wang, Z., & Li, X. (2010). Chinese schools modern distance education project in rural areas. *British Journal of Educational Technology*, 41(4), 612-613. <https://doi.org/10.1111/j.1467-8535.2010.01073.x>

- Wu, Y. (2013). Educational opportunities for rural and urban residents in China, 1978-2008: Inequality and evolution. *Social Sciences in China*, 34(3), 58–75. <https://doi.org/10.1080/02529203.2013.820555>
- Xiong, D. (2016, April 1). The Xian'an remote synchronous classrooms attracts experts from Central China Normal University [In Chinese]. Retrieved from [http://szb.xnnews.com.cn/newb/html/2016-03/01/content\\_159332.htm](http://szb.xnnews.com.cn/newb/html/2016-03/01/content_159332.htm)
- Yang, B., & Wan, M. (2015). Changes in urban-rural social structure and distribution of high school educational opportunities-an analysis based on middle school graduation education tracking in Q County, Gansu. *Chinese Education & Society*, 48, 433–452. <https://doi.org/10.1080/10611932.2015.1119509>
- Yang, C. (2016). Three ways to establish synchronous classroom [In Chinese]. *Hubei Education: General Information*, 8(45). <https://doi.org/10.3969/j.issn.1003-4390.2016.08.029>
- Yang, X. (2014, April 17). The development community of urban and rural school in Enshi shows progress [In Chinese]. *China Selenium Network*. Retrieved from <http://www.ienshi.gov.cn/zxdt/20140417/2226.html>
- Yang, Y., Hu, X., Qu, Q., Lai, F., Shi, Y., Boswell, M., & Rozelle, S. (2013). Roots of tomorrow's digital divide: Documenting computer use and internet access in china's elementary schools today. *China & World Economy*, 21(3), 61–79. <https://doi.org/10.1111/j.1749-124X.2013.12022.x>
- Yang, H.H., Zhu, S., & MacLeod, J. (2016, July). Collaborative teaching approaches: Extending current blended learning models. In S. K. S. Cheung et al. (Eds.), *International Conference on Blended Learning* (pp. 49–59). Cham, Switzerland: Springer. [https://doi.org/10.1007/978-3-319-41165-1\\_5](https://doi.org/10.1007/978-3-319-41165-1_5)
- Ying, L. (2007). Implementing modern distance education project for poverty alleviation, carrying out the western development decisions [In Chinese] *China's satellite radio and television technology seminar*.
- Zhang, J., Yang, J., Fan, L., & Huang, R. (2015). Innovation Scale-Up of ICT in Education in China. In C. K Looi & L. Teh (Eds.) *Scaling Educational Innovations* (pp.179–195). Singapore: Springer. [https://doi.org/10.1007/978-981-287-537-2\\_9](https://doi.org/10.1007/978-981-287-537-2_9)
- Zhou, C., Sylvia, S., Zhang, L., Luo, R., Yi, H., ... Rozelle, S. (2015). China's left-behind children: Impact of parental migration of health, nutrition, and educational outcomes. *Health Affairs*, 34(11), 1–9. <https://doi.org/10.1377/hlthaff.2015.0150>

<http://www.ejmste.com>



For print copies of this issue or articles please send an e-mail to:

[print@modestum.co.uk](mailto:print@modestum.co.uk)

# Teachers' Transformed Subject Matter Knowledge Structures of the Doppler Effect

Mpho Mosabala <sup>1\*</sup>

<sup>1</sup> School of Education, University of the Witwatersrand, SOUTH AFRICA

Received 1 August 2017 • Revised 10 January 2018 • Accepted 10 January 2018

## ABSTRACT

The pupils' poor performance in science in South African secondary schools is well documented. Therefore, it is deemed necessary to conduct a study that would portray knowledge structures for teaching a science topic. This is an empirical qualitative interpretive multiple case study looking at four physical science teachers teaching Doppler Effect to Grade 12 pupils. The data was collected through classroom observations and teacher interviews. Data analysis was done using concept maps. The results show that teachers' knowledge as portrayed during the teaching lack coherence and to some extent the correctness that is expected of teachers. The weaknesses are considered likely to compromise their pupils' conceptual understanding of the topic.

**Keywords:** concept maps, connectedness, correctness, pedagogical content knowledge, subject matter knowledge

## INTRODUCTION

It is a standard practice to measure teachers' professional proficiency in order to comprehend, appreciate and determine the quality of their teaching. This practice is centred partially on the notion that teachers are key intermediaries of any educational activities and that; they have major influence on the quality of teaching and learning (Juttner, Boone, Park, & Neuhaus, 2013). Since teacher thinking plays an important role in influencing teaching process, teachers' professional knowledge especially its structure and quality has taken a centre stage in research. Among others the focus has been on pedagogical content knowledge (PCK) and subject matter knowledge (SMK) of teachers. The assumption is that the way teachers conceptualise the subject matter they teach has influence on how they transform it (Bartos & Lederman, 2014). The transformation is made possible not only by the amount of teacher's subject matter but also how such knowledge is structured (Koponen & Pehkonen, 2010).

This study draws on the theoretical idea of Pedagogical Content Knowledge (PCK) that gives distinction to Subject Matter Knowledge (SMK) transformation (Shulman, 2015; Kind, 2009; Wood, 2003). The transformative PCK framework indicates SMK as one of the teacher knowledge domains from which teachers draw the knowledge they use in teaching. During the teaching process the teachers transform their raw SMK into forms that will be easily understood by their pupils (Geddis & Wood, 1997; Mavhunga & Rollnick, 2013). The SMK that is observed during the teaching has therefore been transformed taking into consideration the curriculum, the pupils and their prior knowledge, what is difficult to teach and conceptual teaching strategies (Pitjeng, 2014). This study focuses on such teachers' transformed SMK which emanates during teaching.

The research has shown that structuring of subject matter differs according to the level of teacher's expertise. The expert teachers have subject matter structure that is more complex with more cross-links, interconnections and chunks (Kinchin, Hay & Adams, 2010). These structural differences have been found to have manifold influence on classroom practice. Teachers with sophisticated complex structure tend to teach in ways that portray such coherence and integration of concepts which is important for conceptual understanding of pupils (Bartos & Lederman, 2014). Pupils' knowledge structures have also been found to resemble those of their teachers, an indication of the influence teacher knowledge has on pupils' understanding (Rutledge & Mitchell, 2002).

### Contribution of this paper to the literature

- This study contributes to the limited literature on creating concept maps from subjects' observations and interview responses.
- This study also suggests the alternative way of portraying knowledge gaps of subjects who cannot construct concept maps themselves.
- The study also highlights the teachers' knowledge structure for teaching Doppler Effect which has not been done before.

The poor performance in physical science in South Africa is well documented. In the past few years the physical science average pass rate at matric has been around 60%. These were pupils who got 30% and above while only around 37% scored above 40% (Department of Basic Education, 2015). This low pass rate has been attributed to various factors among which are teaching strategies (Brodie, Lelliott & Davis, 2002), pupils' interest and motivation (Makgato and Mji, 2006), teachers' subject matter knowledge (Pitjeng, 2014), lack of resources (Legotlo, Maaga, Sebego, van der Westhuizen, Mosoge, Nieuwoudt & Steyn, 2002) and media of instruction (Probyn, 2008). This poor performance has been persistent even though teachers are often taken for workshops by Department of Education. Even though science teachers' subject matter knowledge has been studied in South African context only how much of such knowledge teachers have was researched. The way such knowledge is structured is one area that is still under researched.

The purpose of this study was to find out the structure of teachers' transformed SMK about the Doppler Effect. The topic was chosen because it was one of the few new topics included in the revised South African curriculum. One way of portraying teachers' knowledge structure is through the use of concepts maps. Concept maps are graphical representation of the relationships among concepts indicated with linking lines and phrases which define such relationships (Nakiboglu & Ertem, 2010). The concept maps can be constructed by the subjects or the researcher from subjects' responses, the latter being the case in this study.

The use of subjects' responses to construct the concept maps is not a new idea. Some researchers (Daley, 2004; Iuli & Hellden, 2004; Kinchin, Hay & Adams, 2010; Novak & Canas, 2006; Novak & Musonda, 1991; Rye & Rubba, 2002) have constructed concept maps from either the verbal expressions (interviews) or texts that the subjects have written or even observation transcripts (Daley, 2004). Novak and Canas (2006) constructed concept maps from interview transcripts and the text from a book to represent the author's knowledge. They further suggest that while there is high expectation that methods like interviews, critical incident analysis, case study analysis and others are likely to extract and represent individual knowledge, the use of concept maps is more likely to be the best way to represent knowledge gathered through any of those (Novak & Canas, 2006). Daley (2004; p1) argues, "the maps allow the researcher to see participants' meaning, as well as, the connections that participants discuss across concepts or bodies of knowledge".

The concept maps are normally scored to indicate the level of understanding of an individual. The rubric used have constructs; Complexity, connectedness and correctness (Rollnick, 2014). Complexity is used to describe the teacher's knowledge structures. It is a product of width, depth and cross links (Hough, O'Rode, Terman & Weissglass, 2007). The depth and width of the concept map are used to depict the complexity of teachers' understanding. This is an evaluation of the knowledge structure portrayed. It takes into account the number of concepts on the same level, the number of links in the longest chain and the cross-links. Cross-links are connections between two nodes that are on either same or different levels.

Connectedness on the other hand indicates the number of chunks and the cross-links the map contains. In this case only the correct chunks and cross-links are counted. A chunk is a group of linked concepts for which the leading concept has at least two correct successors ([Appendix A](#)). A successor is a linked word one level down from a node. On the other hand correctness assists in assessing the teachers' level of accuracy of their content. It looks at the number of correct links between the concepts.

## METHODOLOGY OF RESEARCH

### General Research Background

This was an empirical and interpretive qualitative case study focusing on four teachers teaching Doppler Effect to Grade 12 pupils. The focus was on the in-depth analysis of teachers' knowledge about Doppler Effect.



## Research Sampling

Purposive sampling was used to select the participants for this study to maximise the richness of information collected (Guba & Lincoln, 2005). The study was carried out in schools situated in Gauteng Province, South Africa. The four teachers were selected from four schools that have been performing well (75% and above) in physical sciences in the last seven years. The selected teachers held post graduate degrees from the universities in Gauteng Province as it was anticipated that they were likely to provide rich data due to their research experience. These were teachers with more than ten years of science teaching experience who were also willing to participate in the study. These teachers were also given pseudonyms (Mr Libele, Mr Liephe, Mr Tseki and Mr Skeby) in this study.

## Data Collection and Instruments

Doppler Effect is taught during the second school term in the curriculum, which runs from April to June. The three participants (teachers) taught the topic within the stipulated time. However, one of the participants informed the researcher in advance that the school cluster decided that the topic (Doppler Effect) would be covered during the third school term (in August). Therefore the data collection process took place over a period of five months.

The schools were visited before the data collection. These visits gave an insight into the ways the classes were conducted at different schools and context of each school as a whole. The classes were run as normal during the data collection period. The data collection took place in three stages: pre-observation interviews; classroom observation and post-observation interviews. The Interviews were conducted at each teacher's school which took around twenty minutes and were audiotaped. The observation of two lessons was done with each teacher and with each lesson taking about fifty minutes. The observation (videotaped) was meant to capture the transformed SMK as it manifested through teachers' explanations of the concepts during the teaching. Semi-structured interview was employed due to its flexibility as it enables the researcher to probe for more insight in an idea (Opie, 2004). The interviews probed on some unclear statements or explanations done by the teachers during the teaching and their reasons behind some incidents observed during the lesson. Both the audio and video recordings were then transcribed and analysed.

## DATA ANALYSIS

### Data Analysis Background

The study addressed the research question: What is the teachers' transformed knowledge structure of Doppler Effect? In attempting to answer this question concept maps were constructed from teachers' classroom observation and interviews transcripts. The concept maps therefore represented the transformed knowledge of the teachers for teaching Doppler Effect. The concept maps were then analysed in order to identify the structure of teacher knowledge and the knowledge gaps and misconceptions that the teachers could have. The concept maps in this study were not used as data collection method as normally used, but as data analysis tool and this is described in details in the sections that follow.

### Construction of Concept Maps

The concept maps in this study were constructed from teacher interviews, any writing that the teachers made (mainly on chalk board) and from the observation transcriptions. As described in the previous paragraph and under literature review, this was regarded the best way to represent teachers' transformed knowledge about Doppler Effect. The concept maps also assisted in reducing the amount of transcribed data into what Kinchin, Streatfield and Hay (2010; p53) call "structural summaries of knowledge" (information held and the way in which knowledge is structured and individual concepts connected to each other)".

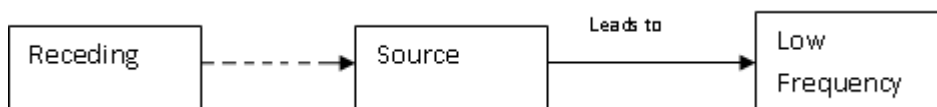
The procedure followed in constructing the concept maps in this study was adapted from Novak and Musonda (1991), Kinchin et al. (2010) and Iuli and Helldén (2004). In their study Novak and Musonda (1991) began the concept map construction by first identifying the statements that represented the participants' ideas about the objects or events picked from the verbatim transcriptions. The starting point is always the most inclusive or general concept covered during the interview or observation.

In this study the concept maps were constructed by the researcher with the help of concept map expert who was also a physical science specialist working at the university. The process started with verbatim transcripts of interviews and observations. The concepts within Doppler Effect were first identified. These were the main ideas that were covered within the interviews or lesson observation as observed from transcripts. These main concepts were later represented as nodes on the concept maps. Subsequently the way in which the teacher linked the

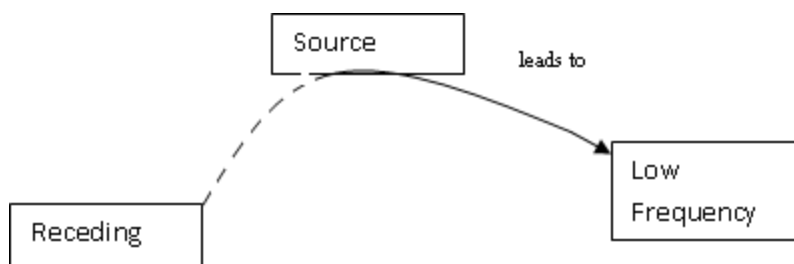
concepts was identified and used to construct the propositions which eventually led to the structure of the whole map. The propositions represented the teacher's ideas about the Doppler Effect.

As a guideline from Novak and Musonda (1991) suggested, a first draft was constructed and revised by going through the transcriptions, video tapes, and voice recorder that contained original records of data. The adjustments were then made to the concept maps to the satisfaction of both the researcher and the expert. In cases where there were disagreements between a researcher and the expert, the propositions were reviewed until the consensus was reached.

During the concept map construction the researcher realised that teachers mostly used different words to refer to the same idea. For an example, the teachers would use the words like a car, siren, an ambulance, a police car to refer to the source of sound or frequency. All these words or terms were represented with a one word 'source' on the concept maps. Furthermore, there were situations where the two concepts would not need a linking word. In such cases a dotted line was used. For instance, one teacher used the concepts receding, low frequency and source. The connection made between the concepts was as follows;



The dotted lines were also used where the arrows crossed each other or went through some nodes because of complication of the concept map. In cases where there were many arrows connecting several nodes to one, it was important to show the propositions with continuous bending arrows. For instance, the propositions below would read as; receding source leads to low frequency.



The propositions like this one were done where the node like 'source' in this case was linked to many other nodes.

### Experts' Map as Point of Reference

The scores obtained from concept maps become meaningless if there is no comparison or some sort of point of reference. Normally concept maps are compared with an expert map which is taken as a reference. Then, the similarity index is calculated (Chang, Sung, Chang and Lin, 2005), or closeness index (Goldsmith, Johnson and Acton, 1991). The starting point in most studies is the expert map. However, in this study the expert concept map was constructed using nodes from teachers' concept maps. This was done to accommodate different nodes used by different teachers. For an example; Mr Libele used terms such as 'produced frequency', 'perceived frequency' while other teachers used terms such as 'increasing frequency', 'decreasing frequency', 'higher frequency', 'lower frequency' and others. These terms could not be represented by a single term because that would change the meaning altogether. For instance, 'increasing frequency' is totally different from 'higher frequency' in the context of Doppler Effect.

In addition to using teachers' existing nodes for construction of expert's concept maps, nodes from new concepts were added. These were the concepts that the researcher and the high school physics expert who was also a researcher found to be necessary according to physical science school curriculum. For instance, when Mr Tseki discussed the applications of Doppler Effect, only redshift was mentioned. The national curriculum statement clearly states that the applications should include both redshift and blue shift; therefore blue shift was added on the expert map. Moreover, nodes and links that were found to be incorrect were replaced with correct one so that the concept map propositions could be correct. For an example, Mr Liephe had node 'distance' where the proposition read as follows "Doppler Effect is caused by distance between listener and source". Distance was then

**Table 1.** Concept maps scores

Teacher	Number of nodes	Number of links with no linking words	Number of incorrect links	Number of superficial links	Number of scientific links	Number of all Cross-links	Number of correct cross-links	Number of chunks	Number of chunks links	Width	Depth
Mr Libele	26	3	2	0	22	1	1	2	8	7	6
Mr Tseki	18	0	2	3	18	6	1	3	13	7	6
Mr Liephe	24	2	5	2	21	6	2	6	12	8	8
Mr Skeby	25	4	0	0	20	2	2	6	19	5	8

**Table 2.** Teacher concept map scores

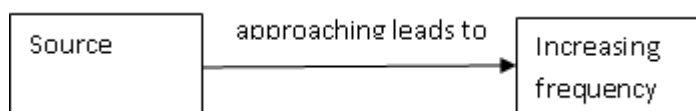
Teacher	Complexity	Connectedness	Correctness
Mr Libele	42	11	365
Mr Tseki	252	17	455
Mr Liephe	384	20	375
Mr Skeby	80	27	336

substituted with ‘relative movement’ which made the proposition to be correct. Furthermore, there were instances where teachers did not make links between concepts that appeared on their lesson. In cases like that the researcher and physics expert made such links where possible. For instance, Mr Skeby did not link the nodes ‘longer wavelength’ and ‘lower pitch’ which were considered related. Subsequently the expert maps were scored for correctness, complexity and connectedness.

### Analysis of Concept Maps

The concept maps were scored using rubric first developed by Novak and Gowin (1984) and adapted by Rollnick, Mundalamo and Booth (2009), Pitjeng and Rollnick (2010) and later Pitjeng (2011). This rubric used the constructs; complexity, connectedness and correctness.

The concept map scores were validated by two colleagues who were physics specialists and researchers. Prior to scoring the concept maps three of us discussed the way the rubric would be used. Then each of us took the four concept maps and scored them independently. The team then came together for comparisons of scores and discussed why each of us scored each map the way it was scored. There were some disagreements about certain aspects of scoring in some cases. In such cases three of us would engage in discussion about the best possible way of scoring such an aspect until a consensus was reached. For an example, two of the colleagues had classified the link between the two concepts shown below as correct.



However, after intense discussion the trio then decided that this was an incorrect link.

## RESULTS AND DISCUSSIONS OF SCORING CONCEPT MAPS

A closer look at the concept maps yielded the information that is presented on the **Table 1**. This information was then used to come up with the scores for the concept map using different constructs.

The scoring of the concept maps using the information in **Table 1** yielded the figures that are shown in **Table 2**.

### Complexity

It can be seen from **Table 2** that the two teachers’ complexity scores were very low while the other two had high scores. Mr Libele had the lowest complexity score while Mr Liephe had the highest one. All four teachers had almost the same value of width and depth. Therefore the large difference observed on their complexity scores was due to cross-links. Novak (1998) argues that cross-links show the creativity hence the higher the number of cross-links the more creative the teacher is. Two teachers had 6 cross-links; one had two while one had one cross-link. The two teachers who had lowest number of cross-links were the ones who had two lowest scores on complexity.

This therefore means teachers ability to make cross-links between concepts was responsible for the difference in the scores observed. According to Safayeni, Derbentseva and Canas (2005) being able to show the relationship between the concepts is associated with insight of topic involved. Hence teachers with high number of cross-links had a better understanding of how to teach Doppler Effect while those with low number of cross-links have less understanding for teaching the topic.

Concept maps structures are normally classified as spokes, chain and network. The spokes and chain concept maps are taken to reflect less complicated knowledge structure (Kinchin, Hay & Adams, 2010; Hay & Kinchin, 2006). On the other, network structures are taken to be the evidence of deep, integrated and holistic understanding of the topic (Kinchin et al., 2010; Kinchin, 2008). The network structures are associated with cross-links between concepts. Therefore, the teachers (Mr Tseki and Mr Liephe) with more cross-links had concept maps which were more of network than chain or spoke. On the other side few cross-links meant concept maps being either more linear (chain) or spoke. This was the case with the other two teachers (Mr Libele and Mr Skeby). Based on this observation alone Mr Tseki and Mr Liephe were supposed to have a better understanding of Doppler Effect than Mr Libele and Mr Skeby.

### Connectedness

Connectedness is calculated by counting the number of chunks, their correct links and the number of correct cross-links. These are then added together to get connectedness. Connectedness was meant to show how good the teachers were in terms of recognizing the relationship between concepts by making links between them. Kinchin et al (2010) and Safayeni et al. (2005) argue that a sophisticated understanding and high quality teachers knowledge is revealed in concept maps that are strongly connected. Thus, high connectedness score reflected good understanding of a topic.

The four teachers had a wide range of connectedness (**Table 2**) with Mr Libele getting the lowest score while Mr Skeby had the highest score. These results therefore indicate that Mr Skeby had a better knowledge of Doppler Effect while Mr Libele had a relatively weak knowledge compared to the four other teachers. The teachers' connectedness difference was mainly caused by difference in the number of chunks and their links since there was only small difference in terms number of cross-links (**Table 1**). Teachers' concept maps had more chunks compared to the number of cross-links. The chunks alone (without cross-links) would give the overall concept map structure that would be described as spoke. This type of concept map structure is an indication of low level of understanding of a topic (Doppler). Therefore considering the number of cross-links for the teachers' concept maps it is possible that teachers did not have enough knowledge regarding the relationship between the concepts they used.

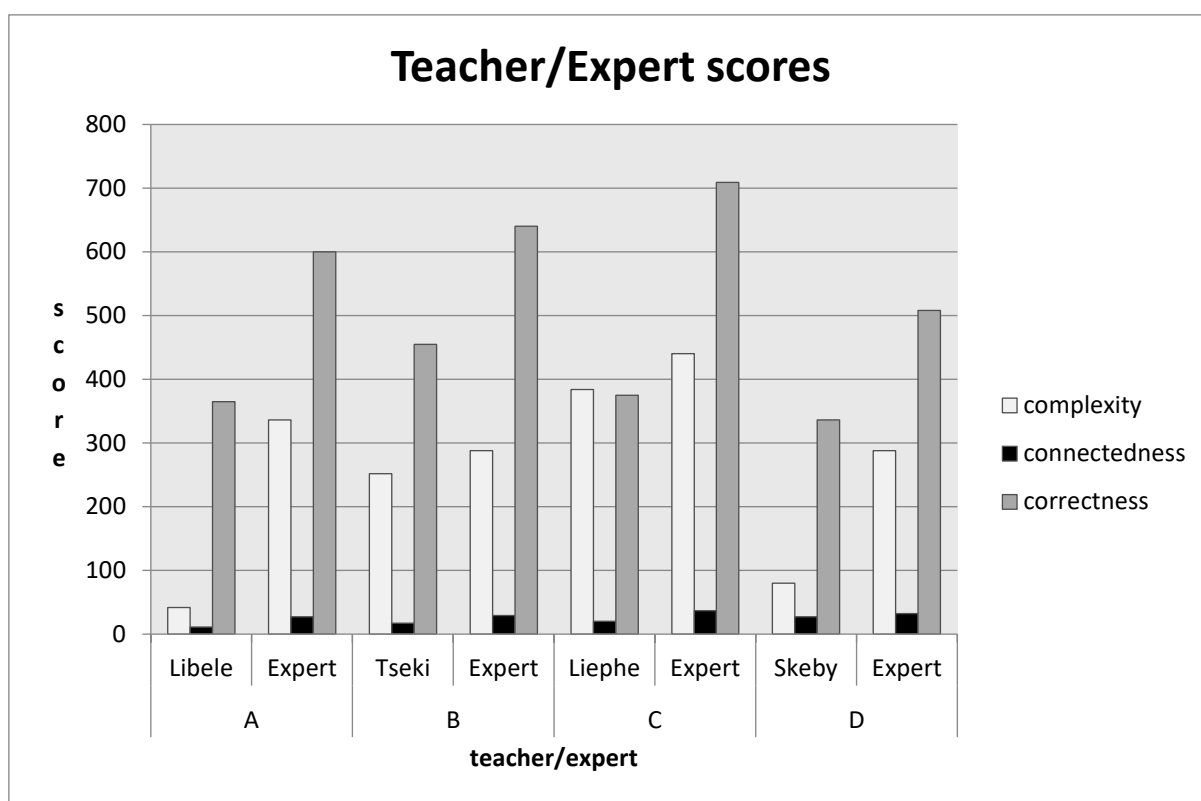
### Correctness

Correctness of the concept map is calculated by counting the number of links and cross-links. The links are then classified and given different scores. Incorrect links were given a score of 0. If the link did not have words it was given a score of 1. If the link represented superficial idea it was given a score of 2. Finally, the link that represented a detailed and sophisticated understanding or what could be described as scientifically rich link was given a score of 4.

**Table 2** correctness scores show that teachers had relatively good understanding of Doppler Effect. This can be seen from the fact that there were few incorrect and superficial links that the teachers made between concepts. Only one teacher (Mr Skeby) did not have what could be described as incorrect link or superficial link, an indication that he had a good understanding of the topic. A small number of nodes, high number of incorrect links and few superficial links between nodes could suggest that Mr Liephe's knowledge of Doppler Effect was limited. Mr Libele and Mr Tseki had high number of links that represent scientifically rich links between the concepts. That could mean they had a good understanding of Doppler Effect. However, the presence of incorrect links between the concepts could mean that there were some aspects of Doppler Effect that they did not understand the way the teachers are expected to understand. The knowledge of the three teachers with incorrect links could therefore be classified as limited.

### Content Experts as a Yardstick for Teachers' Knowledge

The inconclusive nature of using complexity, connectedness and correctness individually to determine the structure hence knowledge of teachers deemed it necessary to make a comparison with experts' concept maps. The teachers' scores for complexity, connectedness and correctness were compared to that of experts. This was done to gauge the highest possible scores that each teacher could have got. **Figure 1** shows such scores. It is however important to note that this figure was not meant to compare the scores among the teachers.



**Figure 1.** Teacher/expert concept map scores

The difference in terms of complexity, connectedness and correctness between the teachers and experts (**Figure 1**) was an indication that teachers' knowledge of Doppler Effect lacked in terms of its accuracy, structure and quality (Safayeni et al., 2005). The lower teachers' correctness scores were mostly a result of teachers either using concepts that were considered unscientific and incorrect, an indication of superficial understanding of the topic (Lachner & Nuckles, 2014). However, Mr Skeby's lower score was attributed to lack of links between some concepts which were deemed necessary by the researcher and as demanded by the curriculum. It is however important to highlight that there was no evidence to indicate that such links were omitted because the teacher did not know that the concepts could be linked. However, the omission of such links was likely to deny pupils to develop a complete and coherent understanding of the topic.

Generally there was some difference between the teachers and the expert in terms of connectedness. This is an indication that teachers lacked the understanding of the relationships between the concepts hence lack of deep understanding of the topic as a whole. However, unlike with 3 other teachers, there was an insignificant difference between Mr Skeby's and the expert's score (**Figure 1**). This could be attributed to the higher number of chunks and the links between them indicating a good understanding of concepts involved.

The complexity was meant to show the depth and width of teachers' knowledge structure. However, the fact that its scoring did not exclude incorrect links and concepts, meant higher scores even for the teachers with superficial understanding of the topic. For instance, **Figure 1** shows Mr Liepche with the highest complexity score hence well-structured knowledge of the topic while the same structure has been mainly contributed by incorrect concepts and links (as shown on **Table 2**). The complexity scores are therefore only reliable where correct concepts and links are used.

## CONCLUSIONS

Based on the analysis of the teachers' and expert's maps it can be concluded that teachers showed lack of coherent knowledge. The lack of such coherence as Koponen and Pehkonen (2010) put it, is unlikely to help pupils create organised knowledge themselves necessary for deep understanding of Doppler Effect. As this incoherence emanates from teachers' raw SMK it is highly likely that such knowledge is also incoherent (Bartos & Lederman, 2014). The lack of links and coherence among some concepts which was also likely to hinder the conceptual understanding of such concepts by pupils was found to be the low key point for the teachers. Teachers' low correctness scores, a result of using incorrect or not scientifically accepted notions and ideas, was a common feature

for the case teachers. Only one teacher, Mr Skeby was found to have scientifically acceptable ideas about Doppler Effect and related concepts. His lower score was therefore attributed to failure to link some of the concepts which would improve the coherence of the topic as whole. However, it was not established whether such failure was because of lack of knowledge regarding existence of such links or not.

Furthermore it was established in this study that even though the use of construct complexity was a common feature when scoring concepts among researchers its inclusion of incorrect cross-links is a limitation. Hence, it might be appropriate that incorrect cross-links are omitted to improve the reliability of the scoring. This limitation is also an indication that the constructs (complexity, connectedness and correctness) cannot be used in independent of each other.

Even though the case teachers in this study had long teaching experience the fact that their transformed knowledge structures did not match that of experts could be an indication that there is an improvement needed with regard to their teaching. Teachers are normally taken through few days (2-5 days) workshops by the Department of Basic Education to be prepared for new curriculum content. However, the findings of this study, though small sample was used, deem more workshops or training on how to teach new topics a necessity.

## REFERENCES

- Bartos, S., & Lederman, N. (2014). Teachers' knowledge structures for nature of science and scientific inquiry: Conceptions and classroom practice. *Journal of Research in Science Teaching* 51(9), 1150-1188. <https://doi.org/10.1002/tea.21168>
- Brodie, K., Lelliott, A., & Davis, H., (2002). Forms and Substance in learner-centred teaching: Teachers' take-up from an in-service programme in South Africa. *Teaching and Teacher Education*, 18, 541-559. [https://doi.org/10.1016/S0742-051X\(02\)00015-X](https://doi.org/10.1016/S0742-051X(02)00015-X)
- Chang, K., Sung, Y., Chang, R., & Lin, S. (2005). A new assessment for computer based mapping. *Educational Technology and society*, 8(3), 138-148.
- Daley, B. J. (2004). Using concept maps in qualitative research. In A. J. Cañas, J. D. Novak, & F. M. González (Eds.), *Concept maps: Theory, methodology, technology: Proceedings of the First International Conference on Concept Mapping (Vol. 1, pp. 191-197)*. Pamplona, Spain: Universidad Pública de Navarra.
- Department of Basic Education. (2015). *Report on the National Senior Certificate examination results*. Pretoria: Department of Basic Education.
- Geddis, A., & Wood, E. (1997). Transforming subject matter and managing dilemmas. *Teaching and Teacher Education*, 13, 611-626. [https://doi.org/10.1016/S0742-051X\(97\)80004-2](https://doi.org/10.1016/S0742-051X(97)80004-2)
- Goldsmith, T., Johnson, P., & Acton, W. (1991). Assessing structural knowledge. *Journal of Educational Psychology*, 83(1), 88-96. <https://doi.org/10.1037/0022-0663.83.1.88>
- Guba, E. G., & Lincoln, Y. S. (2005). Paradigmatic controversies, contradictions, and emerging influences. In N. K. Denzin & Y. S. Lincoln (Eds.), *The Sage Handbook of Qualitative Research* (pp. 191-215). Thousand Oaks, CA: Sage.
- Hay, D. B., & Kinchin, I. M. (2006). Using concept maps to reveal conceptual typologies. *Education & Training*, 48, 127-142. <https://doi.org/10.1108/00400910610651764>
- Hough, S., O'Rode, N., Terman, N., & Weissglass, J. (2007). Using concept maps to assess change in teachers' understandings of algebra: A respectful approach. *Journal of Mathematics Teacher Education*, 10(1), 23-41. <https://doi.org/10.1007/s10857-007-9025-0>
- Iuli, R. J., & Helldén, G. (2004). Using concept maps as a research tool in science education research. In A. J. Cañas, J. D. Novak, & F. M. González (Eds.), *Concept maps: Theory, methodology, technology: Proceedings of the First International Conference on Concept Mapping (Vol. 1, pp. 367-374)*. Pamplona, Spain: Universidad Pública de Navarra.
- Jüttner, M., Boone, W., Park, S., & Neuhaus, B. J. (2013). Development and use of a test instrument to measure biology teachers' content knowledge (CK) and pedagogical content knowledge (PCK). *Educational Assessment, Evaluation and Accountability*, 25(1), 45-67. <https://doi.org/10.1007/s11092-013-9157-y>
- Kinchin, I. (2008). Using concept mapping to locate the tacit dimension of clinical expertise: towards a theoretical framework to support critical reflection on teaching. *Learning in Health and Social Care*, 7(2), 93-104. <https://doi.org/10.1111/j.1473-6861.2008.00174.x>
- Kinchin, I. M., Hay, D.B., & Adams, A. (2010). How a qualitative approach to concept map analysis can be used to aid learning by illustrating patterns of conceptual development. *Educational Research*, 42(1), 43-57. <https://doi.org/10.1080/001318800363908>



- Kinchin, I., Streatfield, D., & Hay, D. (2010). Using concept mapping to enhance the research interview. *International Journal of Qualitative Methods*, 9(1), 52-68. <https://doi.org/10.1177/160940691000900106>
- Kind, V. (2009). Pedagogical content knowledge in science education: perspectives and potential for progress. *Studies in Science Education*, 45(2), 169-204. <https://doi.org/10.1080/03057260903142285>
- Koponen, I. T., & Pehkonen, M. (2010). Coherent Knowledge Structures of Physics Represented as Concept Networks in Teacher Education. *Science & Education*, 19, 259-282. <https://doi.org/10.1007/s11191-009-9200-z>
- Lachner, A., & Nuckles, M. (2014). Bothered by Abstractness or Engaged by Cohesion? Experts' Explanations Enhance Novices' Deep-Learning. *Journal of Experimental Psychology Applied*, 21(1), 1-50.
- Legotlo, M., Maaga, M., Sebego, M., Van der Westhuizen, P., Mosogo, M., Niewoudt, H., & Steyn, H. (2002). Perceptions of stakeholders on causes of poor performance in Grade 12 in a province in South Africa. *South African Journal of Education*, 22, 113-118.
- Makgato, M., & Mji, A. (2006). Factors associated with high school learners' poor performance: a spotlight on mathematics and physical science. *South African Journal of Education*, 26(2), 177-319.
- Mavhunga, E., & Rollnick, M. (2013). Improving PCK of chemical equilibrium in pre-service teachers. *African Journal of Research in Mathematics, Science and Technology Education*, 17(1-2), 113-125. <https://doi.org/10.1080/10288457.2013.828406>
- Nakiboglu, C., & Ertem, H. (2010). Comparison of the Structural, Relational and Proposition Accuracy Scoring Results of Concept Maps about Atom. *Journal of Turkish Science Education*, 7(3), 60-77.
- Novak, J. D. (1998). *Learning, creating and using knowledge: Concept maps as facilitative tools in schools and corporations*. Hillsdale, NJ: Lawrence Erlbaum.
- Novak, J., & Musonda, D. (1991). A twelve-year longitudinal study of science concept learning. *American Educational Research Journal*, 28, 117-153. <https://doi.org/10.3102/00028312028001117>
- Novak, J. D., & Cañas, A.J. (2006). Theoretical Origins of Concept Maps, How to Construct Them and Uses in Education. *Reflecting Education*, 3(1), 29-42.
- Novak, J. D., & Gowin, D. B. (1984). *Learning how to learn*. Cambridge: Cambridge University Press. <https://doi.org/10.1017/CBO9781139173469>
- Opie, C. (2004). *Doing educational research*. Thousand Oaks, CA: Sage.
- Pitjeng, P., & Rollnick, M. (2010). Learning to teach the Chloralkali Industry to Grade 12- In Mudaly, V. (Ed.) *Proceedings of the 18th Annual Meeting of the Southern African Association for Research in Mathematics, Science and Technology Education Durban: SAARMSTE*, 3, 143-152.
- Pitjeng, P. (2014). Novice unqualified graduate science teachers' topic specific pedagogical content knowledge and their beliefs about teaching. In H. Venkat, M. Rollnick, M. Aksew, & J. Loughran (Eds.), *Exploring mathematics and science teachers' knowledge: Windows into teacher thinking* (pp.65-83), Abingdon: Routledge.
- Pitjeng, R. J. (2011). *Developing pedagogical content knowledge through a self-study: a case of teaching "chloralkali industry"* (Unpublished MSc Research Report). Johannesburg, South Africa: University of Witwatersrand.
- Probyn, M. (2008). Policy, practice and power: Language ecologies of South African classrooms. In A. Creese, P. Martin & N. H. Hornberger (Eds.), *Encyclopaedia of 246 Language and Education: Volume 9: Ecology of language* (pp. 207-223). New York: Springer.
- Rollnick, M. (2014). Using self-study to learn new topics in chemistry- A case of three practicing teachers. In H. Venkat, M. Rollnick, M. Askew, & J. Loughran (Eds.), *Exploring mathematics and science teachers' knowledge: Windows into teacher thinking* (pp.147-162), Abingdon: Routledge.
- Rollnick, M., Mundalamo, F., & Booth, S. (2009). Teachers' meanings and intentions in constructing concept maps while learning to teach semiconductors. Paper presented at the *National Association for Research in Science Teaching*, Garden Grove, CA.
- Rutledge, M. L., & Mitchell, M. A. (2002). Knowledge structure, acceptance, and teaching of evolution. *The American Biology Teacher*, 64(1), 21-27. [https://doi.org/10.1662/0002-7685\(2002\)064\[0021:HSBTKS\]2.0.CO;2](https://doi.org/10.1662/0002-7685(2002)064[0021:HSBTKS]2.0.CO;2)
- Rye, J. A., & Rubba, P. A. (2002). Scoring Concept Maps: an Expert Map-Based Scheme Weighted for Relationships. *School Science and Mathematics*, 102(1), 33-44. <https://doi.org/10.1111/j.1949-8594.2002.tb18194.x>
- Safayeni, F., Derbentseva, N., & Canas, A. (2005). A theoretical note on concepts and the need for cyclic concept maps. *Journal of research in science teaching*, 42(7), 741-766. <https://doi.org/10.1002/tea.20074>

- Shulman, L. (2015). PCK: Its genesis and its exodus. In A. Berry, P. Friedrichsen, & J. Loughran (Eds.), *Re-examining pedagogical content knowledge in science education* (pp. 3-13). New York, NY: Routledge.
- Wood, E. (2003). Pedagogical Content Knowledge: An Example from Secondary School Mathematics. *The Mathematics Educator*, 7(1), 49-61.

## APPENDIX A

### Rubric (Rollnick, Mundalamo & Booth, 2008)

#### Definitions

**Node** – a word/concept linked to one or more other words/concepts

**Link** – a direct connection between two nodes on successive levels

**Cross-link** – a connection between two nodes on either the same level or other levels

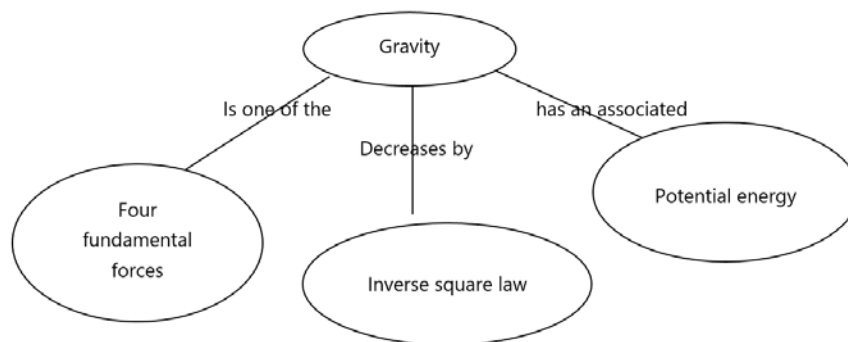
**Successor** – a linked word one level down from a node

**Width** – the greatest number of concepts at one particular level on the map

**Depth** – the length of the longest chain on the map

**Chunk** – a group of linked concepts for which the leading concept has at least two correct successors

In an example below *gravity* is a chunk because it has 3 successors with correct links.



#### Analysis

##### A. Correctness

1. All links are assessed for correctness (cross-links and links)
2. The following rating is provided for each link :
  - 0 = the link is missing or incorrect
  - 1 = a link is present, but there are no words or propositions on the link
  - 2 = the link is represents a basic or superficial idea that while acceptable shows limited or “scientifically thin” knowledge.
  - 4= the link shows a detailed and sophisticated understanding that is “scientifically rich”
3. All of the scores are added for each link and cross-link, and the final score is divided by the number of nodes. This corrects for the fact that some teachers chose to add extra nodes. The formula is:  $(L1) + (L2) \dots / \text{total number of nodes} \times 100 = \text{Correctness}$

### B. Connectedness

1. The correct chunks are determined and the number of correct links (do not include cross links in this count) for each chunk are counted (CNL). A chunk is a group of linked concepts for which the leading concept has at least two *correct* successors.

**Procedural note: in cases where links can be assigned to more than one node always select the link that creates a chunk if applicable**

2. The correct cross-links are determined (CCL).
3. A score for the connectedness is:  
 $nCNL + nCCL = \text{connectedness}$

### C. Complexity

**Procedural note: when redrawing the map in hierarchical form nodes are assigned to a hierarchical level based on their distance from the overarching concept.**

1. The width of the concept map is assessed (W). This is the greatest number of concepts at one particular level on the map.
2. The depth of the concept map is assessed (D). This is the length of the longest chain on the map.
3. The numbers of cross-links are counted (CCL).
4. The formula:  $(W \times D) \times CCL = \text{complexity}$

<http://www.ejmste.com>



<http://www.ejmste.com>



<https://twitter.com/ejmste>



<https://www.facebook.com/ejmste>



<http://modestum.co.uk/>



[publications@modestum.co.uk](mailto:publications@modestum.co.uk)

## Based on Statistical Education to Study Innovative Service and Relationship Quality of University Library under Big Data

Ruiyi Gong<sup>1</sup>, Kaijun Yu<sup>1</sup>, Hongmei Tang<sup>2\*</sup>

<sup>1</sup> Library, Shanghai University of Medicine & Health Sciences, Shanghai, CHINA

<sup>2</sup> School of Nursing and Health Management, Shanghai University of Medicine & Health Sciences, Shanghai, CHINA

Received 21 November 2017 • Revised 2 February 2018 • Accepted 23 March 2018

### ABSTRACT

Along with the evolution of information technology, libraries have become network libraries and virtual libraries, and major technological revolution has changed the management and service of libraries. When providing users with information service, a library should apply statistical education to accurately analyze user needs and habits, enhance the library by designing diverse information service functions, and provide users with an information integration platform. In addition to more convenience for users utilizing library resources, the practice of statistical education would optimize the management process of a library. Aiming at librarians and users of Shanghai university of medicine and health sciences library, the membership database is applied to collect big data. With online questionnaire, total 500 copies of questionnaire are distributed and 387 valid copies are retrieved, with the retrieval rate 77%. The research results show significantly positive effects of 1.statistical education on innovative service, 2.innovative service on relationship quality, and 3.statistical education on relationship quality. Finally, suggestions, according to the results, are proposed, expecting to have libraries constantly create innovative management and service, facilitate users in the utilization of library resources, and integrate systems for optimizing the library management process.

**Keywords:** statistical education, big data, university library, innovative service of library, relationship quality

### INTRODUCTION

The life after 10 years might appear technologies and computers being the major parts of daily life. Nevertheless, people transfer the attention to the human nature and the real effectiveness of technology; technology present perfect balance between virtual and real worlds and people would develop towards "life automation" in the future. Along with the evolution of information technology, the system of a library changes from paper library and automated library to network library and virtual library. Regardless the paper-based era or the digitalized time, the core value lies in "service", which accompanies major technology revolution and changes the management and service of libraries to enhance service quality. Since the establishment of library automation systems, traditional management is changed into reader-need oriented service pattern. The approach of network era has reader needs become diversified. The cooperation of librarians and system staff also creates distinct innovative management and service. However, the real value of a library is not the hardware facilities or the quantity of archives, but is the utilization of archives and the interaction with users. Especially, a university library, in order to integrate academic service, should take reader needs into the service account.

Regarding the information delivery, a library has been considering to effectively provide information for users. For instance, users are not clear of the library resources when new archives are purchased in the library. Moreover, some archives in a library present higher reputation or are arranged being more easily acquired that users cannot easily borrow them because of high use rate. In fact, there are lots of archives with the same categories and of users' interests in the library not being borrowed. A library therefore has to apply statistical education to accurately

#### Contribution of this paper to the literature

- The application of innovative service should take the existing system structure of a library and the technical resources into account so that the library could more smoothly develop innovative service.
- A library could reinforce the cooperative relationship with users by providing customized services to enhance user trust and establish deeper commitment on the relationship quality.
- A library should reinforce the statistical education, enhance the statistical analytical ability, and understand users' use situations, according to demographic variables, behavioral variables, and geographical variables.

analyze user needs and habits, when providing users with information service, to enhance the library by designing diverse information service functions and provide users with the information integration platform. Based on statistical education, this study intends to discuss the innovative service of university libraries under big data and apply big data in Internet of things to discuss the application of innovative service. In addition to providing users with convenient utilization of library resources, the integration of systems could optimize the management process of a library.

## LITERATURE REVIEW

### Statistical Education

Cox (2013) stated that statistics was used for dealing with data, which were composed of numbers; however, they were not simply numbers, but the numbers with contents. Statistics therefore was to find out information from data and make conclusions. Heyne, Boettke, and Prychitko (2013) indicated that statistics aimed to find out the implied information in data through analyses and organization for explaining certain phenomena or making predictions. The so-called statistics was to explain the essence of various social or natural phenomena through descriptive data and organize and analyze data for understanding the meaning of phenomena. The process of statistics contained four points of data collection, data organization and analysis, data characterization, and data explanation. Armstrong and Kotler (2014) indicated that a complete statistical teaching should contain dynamic activities allowing students' actual participation and developing necessary insight or enhancing the level of understanding from relevant data collection. The content of statistics course design therefore was a series of processes to deal with an actual problem, including problem formation, data collection, and data organization, calculation, presentation, and explanation. Rosell, Lakemond, and Wasti (2014) mentioned that statistical education contained the understanding of mean and mode being the representatives of population and the abstract meaning of statistical terms, the realization of phenomena with the information expressed in statistical charts or statistical numbers, the ability to extract meaningful information from statistical charts, the understanding of changes in life through the explanation of statistical charts, and the reasonable prediction of uncertain situations (Gomez & Ballard, 2013).

Referring to Kang and Kang (2014), statistical education in this study includes the following dimensions.

- (1) Process approach: A complete teaching activity should start from forming problems and transforming into statistical problems, collecting data aiming at the problems (including the decision of sample size and the way of sampling), establishing representative data, classifying and organizing data with diagrams or tables for analyses, and describing and explaining the data content, i.e. interpreting the implications of diagrams and tables.
- (2) Basic concept: Concept learned from the designed materials, covering knowledge concepts in the statistics process, according to data organization, data presentation, data explanation, production and report, and statistical chart interpretation.
- (3) Analytical ability: Referring to data organization, data presentation, and data explanation to further understand phenomena, extract meaningful information, analyze, explain, and criticize the information, and reasonably predict or infer uncertain situations according to organized information.

### Innovative Service

Javkhuu (2014) regarded innovation as the process from fuzzy to specific. From the aspect of knowledge creation, Salunke, Weerawardena, and McColl-Kennedy (2013) defined innovation as the process creating related knowledge and information of new affairs. Accordingly, the broad definitions of innovation focused on concepts and regarded innovation as a concept or process with value (Jeong, Jang, Day, & Ha, 2014). Aziz and Omar (2013) pointed out innovative service as the process of a company adding value to business philosophy, culture, and operation process to enhance the profit of served objects from products or services. Wei, Miao, and Huang (2013)



mentioned Kelly and Storey's definition of new products of a service enterprise in 2000 that the products were new for a company or first created in the world and the products could improve existing products and present value-added service (de Farias, Aguiar, & Melo, 2014). Innovative service could be the product, process change, or the outcome of the production process of products with high intangibility, simultaneity, and heterogeneity (Tang, 2013). Gremyr et al. (2014) considered that innovative service showed the characteristics of intangible essence and high customization that closeness was the key of the innovative development of new service. Successful service innovation would constantly create, design, and provide package service, within the bearable risks, to match customers' urgent and general needs (Kindström, Kowalkowski, & Sandberg, 2013).

Referring to Ho and Ganesan (2013), innovative service in this study is divided into the following dimensions.

- (1) Novelty: The difference between new service processes and existing service processes.
- (2) Know-how: The difference in required skills and knowledge between new services or new systems and existing services or systems
- (3) Facility & environment: The changes of service environment with new services or systems, such as place decoration and smooth traffic flow and personnel.

### Relationship Quality

Solomon (2014) pointed out intangibility, complexity, lack of service familiarity, and long time horizon of delivery as the factors in service that the high uncertainties would affect service, while good relationship quality could reduce uncertainties. Batnasan (2014) regarded relationship quality as the quality of interaction between a company and customers which could have customers experience the meaning of quality and enhance the development of long-term relationship. Josiam and Henry (2014) referred relationship quality as the reduction of consumers' perceived anxiety, doubt, and uncertainty after contacting with businesses. Domenico et al. (2014) defined relationship quality as the high-order construct containing various positive relations, reflecting the total intensity of relationship and the satisfaction of interested parties' needs and expectations. Relationship quality referred to the overall evaluation of relationship intensity (Yan, Wang, & Chau, 2013), i.e. customers' attitudes towards services provided by a company; the measurement of the overall evaluation was relationship quality. Nevertheless, relationship quality would determine the continuous interaction in the future. Grönroos and Voima (2013) considered that relationship quality, similar to product quality, could be regarded as the appropriateness to satisfy customer needs for relationship.

Referring to Tsai and Hsu (2014), relationship quality contains the dimensions of trust, satisfaction, and commitment. Customers' satisfaction with service providers' businesses, trust of service providers, and commitment to the relationship with service enterprises are the key elements of relationship quality (Yu et al., 2013).

- (1) Satisfaction: Homme and Raymond (2013) defined customer satisfaction in relationship quality as customers' cognition of overall services and influential evaluation in the service process, according to personal experiences.
- (2) Trust: Tseng and Lee (2014) defined trust as a party believing that another party would be responsible for satisfying the needs, meaning that customers, when facing service suppliers, believed that the service provided by service suppliers would satisfy the needs.
- (3) Commitment: It is generally regarded as a situation, in which the party with relationship tends to certain behaviors and the successive attitudes also tend to the continuous interaction (Namkung & Jang, 2013).

### Research Hypothesis

Zhang and Wu (2013) proposed that innovative service should be developed from new concepts to acquire knowledge for market needs and develop new concepts and creativity through statistical education; with service design and internal/external tests, the new services were invested in the market and improvements were continuously made. Rosell et al. (2014) indicated that, when proceeding service innovation, the conditions of industrial environment should be analyzed with statistical education to filter and select new opportunities conforming to the overall strategies and resources of an enterprise. Armstrong and Kotler (2014) indicated that after confirming the innovation direction, customer needs should be deeply understood at the next stage; statistical education could help an enterprise accurately analyze customer needs, aiming to thoroughly understand customers' problems, pursued experiences, and the reasons for such needs. Kang and Kang (2014) developed innovative service based on customers, which appeared higher probability of success than technology-oriented innovative service to develop multiple effect of customer resources, effectively analyze customers' psychological difficulty and the shortage of market and knowledge with the accurate statistical analysis of statistical education, and allow customers participating in innovation process. In addition to reducing service development costs, it

could ensure the development of innovative service better conforming to the market and customer needs (Gomez & Ballard, 2013). The following hypothesis is therefore proposed in this study.

**H1:** Statistical education shows significantly positive effects on innovative service.

Gremyr et al. (2014) considered that innovative service could maintain the advantages of an enterprise or an organization and could assist in adjusting the provided service to satisfy customer needs. A company or an organization could conform to customer needs and enhance customer satisfaction by developing better innovative service (de Farias et al., 2014). Ho and Ganesan (2013) regarded relationship quality as the relationship between customers and an enterprise, and such relationship was determined by the degree of the innovative service satisfying customer needs; the higher relationship quality on the relationship between customers and an enterprise could better satisfy customer needs. Aziz and Omar (2013) indicated that the value of innovative service provided for customers would affect customer satisfaction and trust, which would influence relationship quality. Accordingly, the following hypothesis is proposed in this study.

**H2:** Innovative service reveals remarkably positive effects on relationship quality.

Domenico, Francis, and Daniela (2014) pointed out the intangibility and changeability characteristics of service that customers perceived high uncertainties when facing complicated and unfamiliar services, and those with longer deliver time; such uncertainties would enhance the possibilities of service failure and negative results. Good statistical education could definitely analyze the service required for customers and provide service for customer satisfaction to reduce uncertainties and affect the relationship quality of continuous interaction in the future (Yan et al., 2013). In the survey of five-star hotels in Seoul, South Korea, Batnasan (2014) indicated that high-quality service would result in high relationship quality. Apparently, definitely analyzing customer needs with statistical education to provide high-quality service could enhance relationship quality (Tsai & Hsu, 2014). In this case, the following hypothesis is proposed in this study.

**H3:** Statistical education presents notably positive effects on relationship quality.

## SAMPLE AND MEASURING INDICATOR

### Research Sample and Object

Aiming at university libraries in Shanghai, China, the librarians and users of Shanghai University of medicine and health sciences are studied. The membership database is applied to collect big data and 500 copies of online questionnaire are distributed. Total 387 valid copies are retrieved, with the retrieval rate 77%. Shanghai University of medicine and health sciences library has the multi-subject, multi-language, and multi-device archives adapted to university teaching and required for scientific research. Besides, it is gradually forming a literature information resource center with rich resources, seamless connection, school coverage, and Innovational service.

### Reliability and Validity Test

The questions applied in this study are referred to domestic and international researchers, and a pretest is preceded before the distribution of formal questionnaire that the questionnaire presents certain content validity. Statistical education, innovative service, and relationship quality are tested the causal relationship in this study. The analysis with Linear Structural Relations model reveals the overall model fit achieving the reasonable range that it presents good convergent validity and predictive validity. Item-to-total correlation coefficients are used for testing the construct validity of questionnaire content, i.e. reliability analysis. The acquired item-to-total correlations coefficients are used for judging the questionnaire content. The item-to-total correlation coefficients of the dimensions in this study are above 0.7, showing certain degree of construct validity of the dimensions in this study.

Reliability analysis is proceeded to further understand the reliability of questionnaire. The formal questionnaire is developed according to the standards, and the measured Cronbach's  $\alpha$  appears in 0.72~0.91, obviously conforming to the reliability range.

## ANALYSIS OF EMPIRICAL RESULT

### LISREL Indicator

LISREL (linear structural relation) model promises Factor Analysis and Path Analysis in traditional statistics and includes simultaneous equations in econometrics that it is the research tool to calculate multiple factors and multiple causal paths. Regarding the evaluation of model fit, preliminary fit criteria, overall model fit, and fit of internal structure of model are evaluated.

**Table 1.** Overall analysis of Linear Structural Model

Evaluation item	Parameter/evaluation standard	result	t	
preliminary fit	statistical education	process approach	0.683	9.63**
		basic concept	0.667	8.87**
		analytical ability	0.696	9.92**
	innovative service	novelty	0.702	10.61**
		know-how	0.711	10.89**
		facility & environment	0.723	11.76**
	relationship quality	satisfaction	0.718	11.43**
		trust	0.731	12.38**
		commitment	0.744	12.67**

Note: \* stands for  $p < 0.05$ , \*\* for  $p < 0.01$ , and \*\*\* for  $p < 0.001$

**Table 2.** Overall analysis of Linear Structural model

Evaluation item	parameter/evaluation standard	result	t
internal fit	statistical education→innovative service	0.825	22.73**
	innovative service→relationship quality	0.851	29.55**
	statistical education→relationship quality	0.837	26.21**

Note: \* stands for  $p < 0.05$ , \*\* for  $p < 0.01$ , and \*\*\* for  $p < 0.001$

**Table 3.** Overall analysis of Linear Structural Model

overall fit	X2/Df	1.682
	GFI	0.974
	AGFI	0.912
	RMR	0.005

Note: \* stands for  $p < 0.05$ , \*\* for  $p < 0.01$ , and \*\*\* for  $p < 0.001$

The data in this study are organized as below. The preliminary fit, internal fit, and overall fit of the model are explained as followings.

**Table 1** shows the complete analysis results of the model. The dimensions of statistical education (process approach, basic concept, analytical ability) achieve significant explanations to statistical education ( $t > 1.96$ ,  $p < 0.05$ ), the dimensions of innovative service (novelty, know-how, and facility & environment) reach the remarkable explanation to innovative service ( $t > 1.96$ ,  $p < 0.05$ ), and the dimensions of relationship quality (satisfaction, trust, commitment) achieve the notable explanation to relationship quality ( $t > 1.96$ ,  $p < 0.05$ ). Accordingly, the model in this study presents good preliminary fit.

From **Table 2**, statistical education shows positive and remarkable correlations with innovative service (0.825,  $p < 0.01$ ), innovative service reveals positive and notable correlations with relationship quality (0.851,  $p < 0.01$ ), and statistical education also appear positive and significant correlations with relationship quality (0.837,  $p < 0.01$ ) that H1, H2, and H3 are supported.

From **Table 3**, the overall model fit standards  $\chi^2/DF=1.682$ , smaller than the standard 3, and RMR=0.005, revealing the proper results of  $\chi^2/DF$  and RMR. What is more, chi-square value is sensitive to sample size that it is not suitable for directly judging the fit. Nevertheless, the overall model fit standards GFI=0.974 and AGFI=0.912 are larger than 0.9 (the closer GFI and AGFI to 1 shows the better model fit) that the model presents better fit indicators.

## CONCLUSION

The research results show that a library could enhance the relationship with users by providing services conforming to user needs to further enhance the trust and relationship commitment. The combination of daily necessities with the Internet, particularly the interaction between sensors and tags, could trace users' movement and any data could be mutually connected to expose users' habits and preference. Statistical education therefore could be applied to accurately analyze big data to enhance the relationship quality between a library and users. However, how to effectively prevent information safety is extremely important. The major challenge of new technology lies in persuading the use of users. Libraries are entering digital libraries, in which information technology is integrated with various automated services and big data are utilized for promoting libraries' statistical analytical ability through statistical education to accurately analyze user needs and understand user opinions for promoting innovative service closer to user needs.

## RECOMMENDATIONS

From the research results and findings, practical suggestions are proposed as below.

1. The automation system management in each library is different. The entire automation system is purchased from an external manufacturer that a library would not modify the internal frame of the system, but think of developing innovative value-added services. For this reason, the application of innovative service should take the existing system structure of a library and the technical resources into account so that the library could more smoothly develop innovative service.
2. A library could reinforce the cooperative relationship with users by providing customized services to enhance user trust and establish deeper commitment on the relationship quality. In this case, it could achieve the benefit of relationship marketing. Aiming at different user groups, a library should utilize information technology for designing distinct innovative services. Different user group, and even the same user group, might have various needs that a library should provide suitable services for users.
3. A library should reinforce the statistical education, enhance the statistical analytical ability, and understand users' use situations, according to demographic variables, behavioral variables, and geographical variables. Innovative service could help a library effectively understand user groups and needs and create more accurate strategies for innovative service to provide unique services, satisfy user needs, and further enhance users' relationship quality of the library.

## REFERENCES

- Armstrong, G., & Kotler, P. (2014). *Marketing: An introduction (GE)* (12th ed.) England: Pearson Education.
- Aziz, N. A., & Omar, N. A. (2013). Exploring the Effect of Internet Marketing Orientation, Learning Orientation and Market Orientation on Innovativeness and Performance: SEM (Exporters) Perspectives. *Journal of Business Economics and Management*, 14(S1), 257-278. <https://doi.org/10.3846/16111699.2011.645865>
- Batnasan, J. (2014). *Exploring relationships among service innovations, customer satisfaction and customer value in airport*. Asia University.
- Cox, R. (2013). *Environmental Communication and the Public Sphere* (3rd ed.). California: Sage.
- deFarias, S. A., Aguiar, E. C., & Melo, F. V. S. (2014). Store atmospherics and experiential marketing: A conceptual framework and research propositions for an extraordinary customer experience. *International Business Research*, 7(2), 87.
- Domenico, D., Francis, E., & Daniela, S. (2014). The Impact of Public R&D on Marketing and Supply Chains on Small Farms' Market Sensing Capability: Evidence from the Australian Seafood Industry. *International Food and Agribusiness Management Review*, 17(1), 37-82.
- Gomez, L. F., & Ballard, D. I. (2013). Communication for the Long Term: Information Allocation and Collective Reflexivity as Dynamic Capabilities. *Journal of Communication*, 50(2), 208-220. <https://doi.org/10.1177/0021943612474992>
- Gremyr, I., Witell, L., Lofberg, N., Edvardsson, B., & Fundin, A. (2014). Understanding New Service Development and Service Innovation through Innovation Modes. *Journal of Business and Industrial Marketing*, 29(2), 123-131. <https://doi.org/10.1108/JBIM-04-2012-0074>
- Grönroos, C., & Voima, P. (2013). Critical service logic: Making sense of value creation and co-creation. *Journal of the Academy of Marketing Science*, 41(2), 133-150. <https://doi.org/10.1007/s11747-012-0308-3>
- Heyne, P., Boettke, P. J., & Prychitko, D. L. (2013). *The economic way of thinking* (13th ed.) New York: Prentice Hall.
- Ho, H. D., & Ganesan, S. (2013). Does Knowledge Base Compatibility Help or Hurt Knowledge Sharing Between Suppliers in Co-competition? The Role of Customer Participation. *Journal of Marketing*, 77(6), 91-107. <https://doi.org/10.1509/jm.11.0570>
- Homme, B. P., & Raymond, L. (2013). Sustainable development practices in the hospitality industry: An empirical study of their impact on customer satisfaction and intentions. *International Journal of Hospitality Management*, 34, 116-126. <https://doi.org/10.1016/j.ijhm.2013.03.003>
- Javkhuu, B. (2014). *Exploring relationships among service innovations, customer satisfaction and customer value in airport*. Asia University, Department of Business Administration, Taiwan.
- Jeong, E. H., Jang, S. C., Day, J., & Ha, S. (2014). The impact of eco-friendly practices on green image and customer attitudes: An investigation in a café setting. *International Journal of Hospitality Management*, 41, 10-20. <https://doi.org/10.1016/j.ijhm.2014.03.002>

- Josiam, B. M., & Henry, W. (2014). Entertainment: Utilitarian and hedonic motivations for patronizing fun experience restaurants. *Procedia-Social and Behavioral Sciences*, 144, 187-202. <https://doi.org/10.1016/j.sbspro.2014.07.287>
- Kang, K. H., & Kang, J. (2014). Do External Knowledge Sourcing Modes for Service Innovation? Empirical Evidence from South Korean Service Firms. *Journal of Product Innovation Management*, 13(1), 176-191. <https://doi.org/10.1111/jpim.12087>
- Kindström, D., Kowalkowski, C., & Sandberg, E. (2013). Enabling service innovation: a dynamic capabilities approach. *Journal of Business Research*, 66(8), 1063-1073. <https://doi.org/10.1016/j.jbusres.2012.03.003>
- Namkung, Y., & Jang, S. (2013). Effects of restaurant green practices on brand equity formation: Do green practices really matter? *International Journal of Hospitality Management*, 33, 85-95. <https://doi.org/10.1016/j.ijhm.2012.06.006>
- Rosell, D. T., Lakemond, N., & Wasti, S. N. (2014). Integrating Knowledge with Suppliers at the R&D-Manufacturing Interface. *Journal of Manufacturing Technology Management*, 25(2), 240-257. <https://doi.org/10.1108/JMTM-12-2013-0171>
- Salunke, S., Weerawardena, J., & McColl-Kennedy, J. R. (2013). Competing through service innovation: The role of bricolage and entrepreneurship in project-oriented firms. *Journal of Business Research*, 66(8), 1085-1097. <https://doi.org/10.1016/j.jbusres.2012.03.005>
- Solomon, M. R. (2014). *Consumer behavior: Buying, having, and being* (10th ed.). New Jersey, USA: Pearson Education Inc.
- Tang, T.-W. (2013). Competing Through Customer Social Capital: The Proactive Personality of Bed and Breakfast Operators. *Asia Pacific Journal of Tourism Research*, ahead-of-print, 1-19.
- Tsai, K. H., & Hsu, T. T. (2014). Cross-Functional Collaboration, Competitive Intensity, Knowledge Integration Mechanisms, and New Product Performance: A Mediated Moderation Model. *Industrial Marketing Management*, 43, 293-303. <https://doi.org/10.1016/j.indmarman.2013.08.012>
- Tseng S. M., & Lee, P. S. (2014). The Effect of Knowledge Management Capability and Dynamic Capability on Organizational Performance. *Journal of Enterprise Information Management*, 27(2), 158-179. <https://doi.org/10.1108/JEIM-05-2012-0025>
- Wei, W., Miao, L., & Huang, Z. (2013). Customer engagement behaviours and hotel responses. *International Journal of Hospitality Management*, 33, 313-330. <https://doi.org/10.1016/j.ijhm.2012.10.002>
- Yan, X., Wang, J., & Chau, M. (2013). Customer revisit intention to restaurants: Evidence from online reviews. *Information Systems Frontiers*, 1-13.
- Yu, Y., Dong, X. Y., Shen, K. N., Khalifa, M., & Hao, J. X. (2013). Strategies, Technologies, and Organizational Learning for Developing Organizational Innovativeness in Emerging Economies. *Journal of Business Research*, 66, 2507-2514. <https://doi.org/10.1016/j.jbusres.2013.05.042>
- Zhang, J., & Wu, W. P. (2013). Social Capital and New Product Development Outcome: The Mediating Sensing Capability in Chinese High-Tech Firms. *Journal of World Business*, 48, 539-548. <https://doi.org/10.1016/j.jwb.2012.09.009>

<http://www.ejmste.com>



For print copies of this issue or articles please send an e-mail to:

[print@modestum.co.uk](mailto:print@modestum.co.uk)



## Didactic Value of Gamification Tools for Teaching Modeling as a Method of Learning and Cognitive Activity at School

Elena V. Soboleva <sup>1\*</sup>, Elvira G. Galimova <sup>2</sup>, Zhumagul A. Maydangalieva <sup>3</sup>,  
Khalimat Khadzhi-M. Batchayeva <sup>4</sup>

<sup>1</sup> Vyatka State University, Kirov RUSSIA

<sup>2</sup> Kazan (Volga region) Federal University, Kazan, RUSSIA

<sup>3</sup> S. Baishev Aktyubinsk University, Aktobe, REPUBLIC OF KAZAKHSTAN

<sup>4</sup> Karachay-Cherkessian State University named after U.D. Aliev, Karachaevsk, RUSSIA

Received 1 August 2017 • Revised 14 December 2017 • Accepted 13 February 2018

### ABSTRACT

The relevance of this article is determined by the possibility to increase the efficiency of teaching modeling at schools by means of involving modern gaming and educational platforms in students' cognitive activity. The problem of the study results from the contradiction between the broad potential of the gamification tools to motivate and involve students in modeling, to improve their skills, and the ideas of the general methodology about gamifying the educational process as well as the lack of well-designed techniques and methods of using the appropriate software to teach modeling at school. The purpose of the study is to define the didactic value of the gamification tools used to teach modeling at school and to develop a methodological approach to the structured lesson planning using computer game instruction technology. The article describes the types of schoolchildren activities, which allow the use of gamification tools for modeling, to develop schoolchildren's research skills and the ability to use modern tools to solve theoretical and experimental problems. It describes methodological methods and recommendations on organizing information and pedagogical interaction between the participants of the educational process by applying educational programs available on gaming platforms both at the level of personal communication between the teacher and the student, and at the level of the tripartite "teacher-student-computer" interaction. The results of the study can be used, firstly, to change the techniques and methods of teaching modeling at school; secondly, to improve conventional training programs included in the curriculum for university students of pedagogical departments and faculties; thirdly, to develop and improve specific educational programs in various subjects on the gaming platforms for schools in order to improve the quality of education, social integration, and career orientation.

**Keywords:** computer game, gamification, tools of gamification of education, teaching modeling at school, activity-based approach to the educational process

## INTRODUCTION

### Relevance of the Research

The most important condition for the effective organization of the educational process, as it is stated in the works of outstanding teachers and psychologists such as Vygotsky (1999), Galperin (2005), Granitskaya (1991), Rubinstein (2002), Kholodnaya (2015) is creating conditions for students' personal growth, training their cognitive skills and

---

© 2018 by the authors; licensee Modestum Ltd., UK. This article is an open access article distributed under the terms and conditions of the Creative Commons Attribution License (<http://creativecommons.org/licenses/by/4.0/>).

✉ [sobolevaelv@yandex.ru](mailto:sobolevaelv@yandex.ru) (\*Correspondence) ✉ [elyagalimowa@yandex.ru](mailto:elyagalimowa@yandex.ru) ✉ [maydangalieva@mail.ru](mailto:maydangalieva@mail.ru)

✉ [halimat56@mail.ru](mailto:halimat56@mail.ru)

#### Contribution of this paper to the literature

- The study has identified possible ways of applying modern gaming platforms and educational programs to gamify teaching modeling as a methodological tool which can contribute to improving the efficiency of the training process.
- Specific materials which can improve the content and technologies for teaching modeling at school by means of computer educational games (training programs on gaming platforms) are suggested.
- The methodology of gamification in teaching modeling is suggested; it motivates students to become more active in the cognition process, develop their research skills taking into account the specifics of the procedure component of the training process in which computer educational games are used in conditions of forming a new gaming style.
- The study has identified the peculiarities of the preparation process, of conducting modeling lessons which apply gamification tools, the problems connected with assessment of the developed projects by the teacher, as well as the difficulties the teacher may face while using specific gamification tools.

abilities, that is, creating conditions for cognitive development in terms of its value, worldview, intellectual, and activity-methodological aspects.

Studies by modern Russian scientists Leontiev, Lebedeva, and Kostenko (2017), Robert (2014), Trofimov (2017), Tyumeneva and Shklyakina (2016), Potaturov (2015), Aleshchanova et al. (2017) describe the role and influence of modeling as a training method on the development of the child's thinking. Different systems, methods, techniques, and pedagogical technologies are based on the above idea; they allow the educational process to be organized in such a way that knowledge acquisition and skills acquiring are not its ultimate goal, but serve as instruments for personal development, the child's becoming a cognizing subject, capable of enriching the accumulated intellectual resources throughout life, adapt them to the changing life conditions, and use them to achieve different goals (Ursul & Ursul, 2015). Nenashev, Okulov and Yulov (2012) define modeling as a type of learning and cognitive activity (during which schoolchildren analyze the text of the task, translate information from one representation of language into another, build a model and explore its properties, work with the model to make it more detailed). According to their studies, learning to model creates conditions for intellectual development of an individual:

- didactic potential for a pupil to be active in cognition;
- a possibility to implement the activity-based approach;
- higher level of independence of cognitive activity;
- convergence of the learning process with the process of real cognition.

Pedagogical ideas and technologies for teaching modeling have received a lot of attention in nowadays in the scientific world, when the computer and different information and communication technologies have become included as educational tools in the educational process (Robert, 2014).

Vasenina and Soboleva (2013) have shown that it is possible to combine practical transformational activity (manipulating an object, examining the model) and theoretical activity (mental actions) when teaching modeling, since the examined object is of the informational type: it is a model which is being developed, the computer program (software), the information environment, or the information product created in this environment, i.e. a text document, an electronic table, an electronic database and others. Although these are cyber objects and models, the cognizing individual can influence them, manipulate them, create certain conditions for them, watch the reaction and the changes that occur. What is more, such activities are based on a serious theory, fundamental science, and the more fundamental the knowledge necessary for transformation of the object and obtained in the course of work is, the more interesting and valuable experience it is to work with the object (Yakimanskaya, 2011). On the one hand, transforming information objects and working with the model requires performing complex mental operations, thus close relation of informatics to mathematics and language is manifested. On the other hand, the computer makes it possible to take practical actions, manipulate the object and experiment on the model, which brings informatics closer to practice-oriented disciplines (Chubik et al., 2013).

Synthesis of studying fundamental concepts, principles, and regular patterns with the activity approach to teaching modeling produces the best results if the research model corresponds to the fundamental knowledge which should be acquired in the process of studying the universe associated with the information processes (Mayer, 2016; Rozhina & Baklashova, 2018). A computer program is the most appropriate object in this respect. This information object has a quality of complexity and a high level of abstraction, therefore to develop it, it is necessary to know some fundamental informatics concepts (object, system, structure, model, algorithm, etc.) and methods of scientific knowledge (modeling, experiment). While creating a computer program, the pupils acquire such intellectual skills as structuring, planning, forecasting the results of their activities, searching for information, classifying, reasoning, etc. (Beshenkov et al., 2016).

Gamification is seen as one of the innovative technologies which are going to have a significant impact on education in the most technologically developed countries of the world (Dichev, 2017; Lebedeva et al, 2018), and it is considered one of the new approaches which can bridge the gap between the generation of teachers and the generation of students (Kapp, 2007). It is in these contexts that experts appreciate the universal character of gaming used in the classroom, as homework or final testing, or used as the main learning activity to motivate students, improve their skills and quality of education, including when teaching modeling (McVey, 2013).

Let us highlight the opportunities provided by gamification tools when working with the model which can be useful in training:

- reasonable, strategic and appropriate use of gamification elements when training modeling can create a learning situation characterized by increased student participation, which, in turn, leads to positive changes in the cognitive, emotional and social fields (Brull & Finlayson, 2016);
- gamification elements can actually increase the level of internal motivation, since they help to make boring tasks interesting (Cakiroglu, Basibuyuk & Guler, 2017);
- gamification in working with the model makes it possible to increase the student's engagement in the modeling process. The engagement is seen as the student's attention to the task and the student's absorption in the task, although the tasks are given by the teacher (Maloshonok, 2016; Su, 2017);
- gamification develops problem solving skills by means of a complex system of rules that encourages active research and discovery while learning modeling (Polyakova & Kozlov, 2015);
- gamification makes it possible to "reconsider making mistakes as a necessary part of learning" because a mistake provides an opportunity to try, to practise and improve the model (Sokolowski, Yalvac & Loving, 2011);
- repeated failures in studying the model allow one to learn something different and new (Chou, 2017);
- the social character of gamification environments that allows students to socially identify themselves, increase social activity, and appreciate the achievements which otherwise might have remained unnoticed (Borisenko, Yatsenko & Chernykh, 2016).

Each of these attributes can bring not only undeniable advantages contributing to achieving the goals of the educational process, but they can also have a significant negative impact on the educational process (Grigoriev, 2016). It is important to note that the opportunities provided by the new tool are not created by themselves. It is necessary to select appropriate instructional methods, to change the structure of the lesson in favor of activating the cognition process, implementing the experiment, and organizing the cognitive activity of students on gaming platforms and educational services.

At present, most of the existing games do not meet the requirements of teaching modeling at school, so they can be only partially included in the educational process: at a particular stage of working with the model, or to develop mental processes: thinking, memory, attention and imagination (Aykac, 2015; Duvanov, 1989; Luchenkov, 2016). It should also be mentioned that software developers of programs having the potential for learning modeling, in most cases, do not discuss the form and content of the resources with their end-users: school and university teachers (Babintsev et al., 2016).

The analysis of domestic and foreign studies indicates weakness of the psychological and pedagogical principles of the development and implementation of gamification tools in educational and cognitive activities in modeling. This leads to a problem that manifests itself in the necessity to implement the didactic potential of gaming tools for motivating and involving the students in the modeling task and improving their skills. It is important to expand the understanding of the general methodology for gamifying the educational process and develop the gamification techniques used to teach modeling at school.

## Research Goal and Tasks

The goal of this research is to elicit the didactic potential of gamification tools for teaching modeling at school and to suggest a methodical approach to the structured planning of a lesson using the computer game technology.

The main tasks of the research are the following: studying the experience of incorporating the tools for gamifying education into educational and cognitive activities in modeling at school; identifying the types of schoolchildren activities which allow applying gamification tools to teach modeling, developing research skills and abilities to use modern tools when solving theoretical and applied problems; suggesting methodological techniques and recommendations on the organization of information and pedagogical interaction between the participants of the educational and cognitive activity in modeling applying educational programs available on gaming platforms both at the level of personal communication between the teacher and the student, and at the level of the tripartite "teacher-student-computer" interaction.

## LITERATURE REVIEW

Many outstanding educators and psychologists, such as Vygotsky (1999), Galperin (2005), Kholodnaya (2015), Yakimanskaya (2011) acknowledge an important role of modeling as an educational and cognitive activity in shaping the skills of identifying the main relations and patterns, manipulating with the properties and characteristics of the object, and combining them as a whole. Robert (2014), Borisenko, Yatsenko and Chernykh (2016) also argue that it is well-developed creative thinking that can enable individuals to easily adapt to the changing conditions and successfully identify themselves and realize their potential in the modern information environment.

Polyakova and Kozlov (2015) as well as Potuturov (2015) demonstrated that the school information-educational environment, rich in computer technologies and software, has a rich didactic potential for the formation of personal qualities and skills mostly required in the modern society. At the same time, many scientists like: Vasenina and Soboleva (2013), Luchenkov (2016), Maloshonok (2016) highlighted an important fact that is, new technical training tools should be used for transition from the empirical type of training based on passive perception of the material to the developmental type of training, in which the main role in the educational process is played by the active cognitive activity of the student.

Modeling as a kind of educational activity receives breakthrough instructional tools in such conditions (Vasenina & Soboleva 2013): as well as software, virtual laboratories, computer constructors and simulators, etc. Robert (2014), Trofimov (2017), Tyumeneva and Shkلياeva (2016) took a close look at the use of information and communication technologies to increase the efficiency of teaching modeling at schools.

Employing the ICT tools for modeling as a method of scientific knowledge makes it possible to enrich and expand the range of objects of study: the computer as technical equipment and a model, the software itself, computer networks, programs, graphics, tables, etc. Robert (2014), Chubik et al. (2013) place a special emphasis on new types of independent educational and cognitive activity which make the essence of modeling: analyzing the text of the task, acquiring information and transforming it from one form of representation into another; creating an information model and working with it, etc.

It is worth mentioning that in teaching modeling with ICT tools, it is necessary to distinguish between the procedure and content components of organization of this educational and cognitive activity (Robert, 2014).

According to Vasenina and Soboleva, (2013), the procedure component of an educational and cognitive activity means that students:

- can identify specific properties of the object of modeling that are essential for the purpose of modeling (the object is understood to be any object, process or phenomenon);
- create a model, which reflects the essential properties of the object;
- test the model in real and artificial conditions;
- find out if the model corresponds to the object of modeling;
- assess the extent to which the purpose of modeling has been achieved.

The content component is determined by the object of modeling which can be represented as:

- an activity as a series of actions which can be formalized (the model is an algorithm described in a natural or formal language);
- economic relations, mathematical patterns (the model is an electronic spreadsheet with formulas and functions, or a database);
- information on an electronic medium in the form of files (the model is a structured system of files and folders on the disk drive);
- events and facts (the model is represented as expressions composed of logical statements and truth tables).

In addition, the right choice of an appropriate software tool is also quite important for developing skills of designing and studying the model. Text processing programs, spreadsheet graphic editors, presentation creation tools, different programming languages and environments are used in teaching modeling at school (Robert, 2014).

At the same time, the requirements of the society, the state and the education system are changing, which is reflected in the educational standards. New challenges require the learning process to be more focused on the personality of the learner and the changes that occur to it during the learning process, but not just on the accumulation of knowledge (Robert, 2014). In practice, however, these challenges are faced in conditions of the traditional classroom lesson system, though enriched with new tools, methods and forms of instruction, but aimed at giving the children a fixed amount of information within 45 minutes of the lesson (Soboleva, Karavaev, & Perevozchikova, 2017). Therefore, there are studies which urge to reorient the process of providing educational information to solve the fundamental task of individualizing the learning process (Grigoriev, 2016; Soboleva et al.,

2017; Ursul & Ursul, 2015). To achieve this, computer games and online game format services are now included in the school system of education (Grigoriev, 2016). For example, the "Uchi.ru" resource in Russia is used to work with numerical information; the gamification tools on the "Yotx.ru" website gives a possibility to work with function graphs, to design mathematical models in the form of formulas; iSpring provides tools to carry out an independent research activity in teaching modeling (Maloshonok, 2016; Soboleva et al., 2017).

Although there are quite a lot of study aids and software packages Soboleva and Karavaev (2017) aimed at employing game elements in educational activities, "Robotlandia" is one the best elaborated resources from the point of view of methodology, gamified modeling teaching, and the formation of appropriate skills (Duvanov, 1989). This training complex offers training at two methodologically worked out levels. A computer, a text, a picture, a text, a graphic and music editor, information interaction space (for example, a chess field) serve as models at the first level. At the second level, children work with more complex information objects: labyrinths, algorithms, programs, black boxes (Bukvoed). Then one can proceed with "AziInformatiki" (Basics of Informatics), an electronic interactive platform for schoolchildren, where cognitive reading is combined with working on numerous simulators, performers, testers and constructors, it is also accompanied by controlling and testing in test rooms, and all these within a single hypertext browser. However, the drawback of this resource is that it is based only on the basic course of computer science; it cannot be applied to teach other school subjects. And unfortunately, it does not meet modern requirements (Grigoriev, 2016).

The revolutionary idea of Papert (1980) that a computer is only a tool which can make teaching (or more precisely, learning) more interesting, fast, and simple allows us to consider the learning environment as a concept of microcosms which are, in fact, models of the real world which children create themselves in a more or less detailed degree (Soboleva, Karavaev, & Perevozchikova, 2017). This idea justifies the necessity to use computers in teaching the humanities at school. Logo environment has been developed to support this idea. The didactic potential of this resource cannot be overestimated: there are tools to model physical phenomena, processes of interaction and activities of several objects, etc. Logo helps to visualize historical events, geographical discoveries, and biological connections. And the most surprising thing is that the gaming resource helps to study such important fundamental concepts as: performer, instruction code, algorithm, method, magnitude. The most valuable idea, in the context of this research, is that this environment allows us to teach children by studying artificial intelligence (Kholodnaya, 2015). The latter is especially important as it helps students to vividly imagine their own thinking processes.

These ideas have been developed in other software educational tools, used in teaching modeling in the game format. Scratch should be mentioned in the first instance (Soboleva, Karavaev & Perevozchikova, 2017). This visual object-oriented programming environment was originally developed to be used in teaching junior and middle school students, but Scratch potentialities are so diverse that it allows teachers to create comprehensive educational programs (Soboleva & Perevozchikova, 2017). The didactic potential of Scratch in teaching modeling can also be realized at any school subject. One can create virtual worlds in literature, physics, music, etc. designing game educational projects (Soboleva, Karavaev, & Perevozchikova, 2017).

The necessity to integrate gamification tools in educational and cognitive activities in order to develop research skills of an individual is discussed in the works by Koroleva (2016), Maloshonok (2016), Polyakova and Kozlov (2015), however the issue still does not have a comprehensive methodological solution.

The first problem faced by a particular subject teacher who intends to incorporate the gaming technology in the educational and cognitive activity is choosing a software tool that satisfies gamification requirements and has the maximum effect in terms of achieving the learning objectives. The solution to this problem is suggested in the work by Soboleva and Karavaev (2017). A detailed analysis of computer services and platforms has been carried out. The following criteria have been taken into consideration: whether it is easy to master (for subject teachers who are not specialists in the technical aspect of the program) and easy to use in teaching; if it has a Russian interface; if the service is paid or free; what is the range of functional capacities of the community. The analysis has identified some gamification platforms and services which more or less correspond to the gamification principles; they are Scratch, Kodu, Quandary, and some others.

Another methodological problem is the necessity for appropriate teacher training with regard to mastering the functional capacities of gamification tools. The solution to this problem is suggested by Soboleva and Perevozchikova (2017) who illustrated it with the case of developing a game educational project in the Scratch programming environment. However, surveys and questionnaires conducted with schoolchildren and students of teacher training faculties have shown that a possibility to work in a software environment with the 3D-game developing tools is of greater interest and a better incentive for modeling (78% of respondents). The results of questioning demonstrate that such modeling environment presupposes realization of the creative potential of students, development of their thinking abilities, a higher disposition to analyze the situation and to a non-standard approach to solving various problems. "Kodu" turns out to be of the greatest interest (64% of respondents) for students. One of the reasons for choosing this gamification tool for teaching modeling is that Kodu Game Lab is a

3D gaming modeling environment that meets the students' needs (<https://www.kodugamelab.com>). The latter can be used to correctly set the motivation task, to design a system of educational problems. Another reason, as we see it, is that systems of lessons or series of lessons devoted to the solution of a specific modeling problem are inadequately designed from the point of view of methodology.

In Russia, the studies on this issue often only enumerate the main potentialities of the program and discuss some assumptions regarding the use of the visual constructor in the learning process, for example that "learning based on Kodu Game Lab can contribute to the achievement of the educational results" (Chubik et al., 2013). It is also worth mentioning that in the works discussed, Kodu is supposed to be used in out-of-class activities.

Thus, this study is focused on the methodological peculiarities of gamification of the learning process with Kodu Game Lab tools. The developed parts of the lessons are aimed at teaching modeling during lessons at school; therefore they include monitoring of how well the material is learnt through follow-up questions and individual tasks.

Emerson, English, and McGoldrick (2016), Papert (1980), Rogoff and Morelli (1989) highlighted in their works the importance of educational and cognitive activity in modeling in the development of the child's thinking. Different approaches to teaching modeling at school, the didactic problems and methodological experience in different school subjects are discussed in the studies by Akwee, Toili, and Palapala (2012), Edwards & Head (2016), Kubiato et al. (2010), Manz (2012), Sokolowski, Yalvac, and Loving (2011).

There are interesting developments devoted to learning based on "experimental fumbling", independent discovery by Freinet (1950). Foreign scientists, such as Denning et al. (1989), Papert (1980), Scanlon (2010) and others, have made a great contribution to the description of the influence of education computerization on the intellectual development of schoolchildren, on their cognitive activity. Studies by Kuznetsov and Beshenkov (2005), Papert (1980), Husen and Tuijnman (1991) are of significant importance for understanding the role of the computer used as a learning tool to develop creative thinking; they also stress the importance of developing research skills, admit the didactic potential of training based on working with information models.

In modern learning methodology, a lot of attention is also paid to the description of trends in teaching modeling, studying the changes in the learning process which occur when computer technology is introduced, and the conditions for improving the efficiency of the learning process (Kelly, Koates, & Naylor, 2016). For example, the didactic potential of web-based tools and computer simulations used to teach modeling is described (Aykac, 2015; Jacobson, 2006; Mayer, 2017). A special attention is given to the possibilities created by Internet technologies for organizing the research activities, working with information (Robert, 2014). Information systems which take into account the principles of personalized learning have been worked out. For example, an interactive educational environment paying special emphasis to different cognitive styles is presented in the paper by Hamada and Hassan (2017).

Faiella (2015), Hasegawa, Shibasaki, and Ito (2015) highlighted the necessity to modify the learning process in line with the new challenges to the education system. One of the options suggested is gamification of the educational and cognitive activities (Deterding, Kahled, Nacke, & Dixon, 2011).

Analyzing various definitions of the term "gamification" in foreign studies Deterding et al. (2011), Llorens-Largo, Gallego-Duran, and Villagra-Arnedo (2016), Marti-Parreno, Mendez-Ibanez, and Alonso-Arroyo (2016), one can see the agreement among the scientists who consider gamification as an approach employing gaming functions (elements, mechanics, frames, aesthetics, thinking, metaphors) in non-gaming situations. The term gamification is used in relation to many aspects - the ubiquity or universal character of the computer and video games in everyday life; the necessity to arouse and support students' interest in learning - in order to attract the users and encourage them to achieve more ambitious goals, to follow the rules, and to entertain. Gamified modeling activity is accompanied by active students' involvement in the task, their higher motivation (Su, 2017). In addition, all stages of modeling have a visual representation, so knowledge, skills, thinking of students are developed through the gradual development of the gaming space.

Thus, the use of the described software provides the possibility to incorporate gaming elements into a non-gaming context if there is appropriate methodological support (Deterding et al., 2011). In other words, the teachers get at their disposal a range of tools to enhance the users' engagement; it consists of gaming elements and techniques, and there is no need to change the modeling learning activity itself (Semenov, 2017). In fact, it is gamification of the educational process. Thus, we have determined the potential value of gamification tools in teaching modeling.

Cózar-Gutiérrez and Sáez-López (2016), McVey (2013) gave examples of successful projects of gamification in education. For example, Cózar-Gutiérrez and Sáez-López (2016) describe in detail the methodological experience of using the *MinecraftEdu* constructor. Pennington and McComas (2016) emphasize the positive aspects of computer games which can be used to: train the skills of solving practical tasks, create conditions to develop independence in cognitive activities while modeling, enhance the teacher-student relationship, expand the range of tools for



constructing and studying information models, improving decision-making, and obtaining immediate feedback. Dichev and Dicheva (2017) emphasized the problems of methodological support of gamification of the educational and cognitive activities in the information environment, the necessity to take into account its negative impact on the content component of training (shifting the emphasis from the incentive to acquire new knowledge to the desire to score more points). They considered it important to use a wide range of methods balancing external and internal motivators (Bodnar & Clark, 2017; Dichev & Dicheva 2017) and develop the gamification methodology to ensure that all students in class can acquire and develop the research skills in comfortable conditions (Cakiroglu, Basibuyuk & Guler, 2017; Brull & Finlayson, 2016).

In addition, summarizing the results of numerous surveys and questionnaires, Cózar-Gutiérrez and Sáez-López (2016), made a conclusion that the main methodological problem for subject teachers is selecting a gamification tool, understanding the technical peculiarities of working with computer platforms and services, working out fundamentally new lesson plans (for example, designing the scoring system, looking for methods preventing distraction of students' attention). At the same time, the teachers are insufficiently trained to actively use all the methodological capabilities of modern services and facilities (Dichev & Dicheva, 2017; Kapp, 2007). Since this study thoroughly considers the methodological peculiarities of gamification in teaching modeling by means of "Kodu Game Lab", we should note that most of the articles devoted to the use of this visual designer in the training process contain methodological recommendations on using "Kodu" in extracurricular activities or working with video lessons (Kelly, 2013).

To maximize the didactic potential of gamification tools for teaching modeling at school, it is necessary to improve the methodology of gamifying learning, taking into account that it is primarily important to focus on those thinking qualities and skills that develop most effectively when working with the text of the task, transforming information from one language representation into another, creating a model, studying its properties and perfecting it.

This approach to teaching modeling will contribute to the development of the following skills of schoolchildren: being able to change the future outcome of the simulated situation depending on the efforts made; thinking of various options for the scenario development, as each scenario is not influenced by the past but depends only on the decisions of the participants of the situation.

## MATERIALS AND METHODS

### Theoretical and Empirical Methods

The method of analysis of the psychological, pedagogical, methodological and technical literature by foreign and domestic authors whose authority and scientific reputation are recognized by the scientific community has been used to determine the significance of modeling as a method of educational and cognitive activity. To determine the role of ICT tools in improving the efficiency of teaching modeling at school, the method of analyzing the projects developed by subject teachers in the field of teaching modeling at school, as well as scientific and methodological literature on the use of ICT tools in teaching modeling has also been employed.

The method of analysis of gaming platforms and educational services used to gamify the educational process in the context of the state and society requirements, and individual needs has been used to formulate the problems of gamification of education and to describe the specifics of the use of gaming computer technology based on modern software.

The method of systematization and generalization of facts and concepts has provided the possibility to formulate the main ideas of the method of gamification of teaching modeling, to suggest specific recommendations for teachers. The forecasting method helped to determine the didactic potential of modern gamification tools in school education, and to formulate a hypothesis regarding qualitative changes in learning outcomes. The method of mental experiment has been used to verify the ideas of methodology, practical ways and techniques of gamification of teaching modeling as a method of educational and cognitive activity of schoolchildren.

At the stage of the pedagogical experiment, empirical methods were employed: involved observation, questioning, testing, analyzing the outcome of the students' learning and cognitive activity. These methods have allowed the obtaining of information about real changes in schoolchildren motivation, their involvement in the modeling task, an increase in students' activity in cognition, development of research skills and skills of independent work with the model.

## **Research Base**

The results of the research have been verified, generalized and implemented by:

- delivering the course in Technology of Creating Training Programs for students trained in the field of 02.04.01 Mathematics and Computer Sciences (first year of the Master's Degree) based on the materials developed by the authors; the course has been run since 2012, first at the Vyatka State University (Russia) and Kazan (Volga region) Federal University (Russia), Karachay-Cherkessian State University named after U. D. Aliev (Russia), S. Baishev Aktyubinsk University, Aktobe (Republic of Kazakhstan) (since 2016);
- delivering the course in Theory and Methodology of Teaching Computer Science for students trained in the field of Pedagogical Education (Informatics and English, 3-4 years of studies) based on the materials developed by the authors; the course has been run since 2010, first at the Vyatka State University (Russia) and Kazan (Volga region) Federal University (Russia), Karachay-Cherkessian State University named after U.D. Aliev (Russia), S. Baishev Aktyubinsk University, Aktobe (Republic of Kazakhstan) (since 2016).

## **Research Stages**

There were three stages in the research.

At the first stage, an ascertaining experiment was carried out: the state of the problem of using modern gaming platforms, educational services for gamification of educational and cognitive activity in modeling at school was studied taking into account the state, society, and individual requirements. To do this, we carried out the analysis of psychological, educational, methodological and technical literature, computer educational games, gamification software in order to identify possible organizational forms of employing the gaming services and platforms in school education. In addition, the analysis of the methodological experience of teaching modeling at school, of using ICT tools to organize modeling activities was conducted to determine the didactic potential of the gamification tools in regard to teaching modeling.

The second stage was devoted to the development of methodological recommendations on the organization of information and pedagogical interaction between the participants of educational and cognitive activities in learning modeling in which training programs on gaming platforms are used, both at the level of personal communication of the teacher and the student, and at the level of tripartite "teacher-student-computer" interaction. The instruments that have a didactic effect and are mostly consistent with the idea of gamification of teaching modeling at school were selected. The discussion of the research results has been carried out in the form of reports at conferences and seminars at various levels, which provides for consistent improvement of teaching methods in computer science, physics and mathematics in practice.

The third stage was run in parallel with the second one; during it the experimental teaching was conducted according to the suggested methodology of gamification of teaching modeling, which takes into account the positive experience of domestic and foreign designers, serves as their development and aims at eliminating various methodological, technological and practical contradictions. In addition, a pedagogical experiment is being carried out, the results of which have already confirmed the efficiency of the developed methodology in improving the quality of the practice-transformational (manipulating an object, studying the model) and theoretical activities (developing mental actions).

## **RESULTS**

### **The Fundamental Principles of the Methodology**

Most often, the following logic of exploring the gamification tools in regard to teaching modeling is observed: students are asked to perform a series of tasks that are not connected by a common idea. The main goal of such classes is studying the interface, getting to know the basic concepts of the environment, mastering the tools and their functional capacities. This allows one to create a general understanding of the modeling environment, gain experience in creating a model and implementing it by means of the program, and develop the skills of working with the ready-made models with a quite large number of various tasks (Soboleva, 2012).

At the same time, the drawback of this approach is that students can experience considerable difficulties in developing their own game space due to lack of relevant experience. This results from the fact that the student cannot combine various practical skills obtained in solving the set of unrelated tasks, as they solve each set of tasks in isolation.

The methodological recommendations on creating one's own game space are suggested to help students acquire experience in educational and cognitive activities in order to develop the modeling skills. The key idea is to conduct a series of lessons in which students develop and implement an interactive video game in a particular school

subject. The study describes a series of lessons that can be used to teach modeling in the school courses of both Mathematics and Physics. Methodological recommendations are formulated without going deep into the programming process, without giving the detailed instructions and descriptions of the properties of objects. This approach is explained by the fact that the aim of the study is to disclose the didactic potential of gaming tools for teaching modeling, but not to study the programming characteristics of the “*Kodu Game Lab*” environment. The subject teachers can develop independently a detailed guide for preparing the lesson notes for the series of lessons taking into account their own experience and resources.

The idea is as follows: there are 5 race tracks on the playing field, and there is an object in each field. When the game starts, the racer have to cover a certain distance, then stop; the player is asked to calculate the parameters of each racer’s movements and take a small test.

So, the students have to create a game in which 5 objects will compete in speed, and the players will compete in the knowledge of the Physics laws and the correctness of mathematical calculations. The students are offered a ready-made idea of the world, aimed at gaining the modeling skills while studying the motion characteristics (trajectory, speed, time, measurement units). The theoretical concepts which are being worked at in the process of modeling the world are fundamental for understanding the scientific reality. Moreover, the students get acquainted with the basic concepts of the visual modeling environment, the gamification principles; the didactic potential for the development of creative thinking and research activities is realized in the process of implementing this project.

## The Lesson Series

### *Lesson 1. Getting acquainted with Kodu visual environment*

Step 1. Studying the main terms

Step 2. Starting to model a new gaming world

At the first lesson, the basic terms and the environment interface are studied, and examples of the ready-made worlds are explored. The students get registered at the start of the application and try to create their own game space (landscape). They create a model of the terrain of a suitable size, and they also simulate the race tracks.

After some of the features of *Kodu Game Lab* have been investigated: the interface has been studied, the skills of adding a character have been acquired, and peculiarities of the movement control and of turning to a certain side have been learnt, the following questions can be offered for discussion:

What are the characteristics of the path / the landscape?

How can you choose the landscape type? How can you delete a part of the landscape? How can you change the material type used to design the landscape? Perform each of the above commands.

How many material types are there?

How are the paths along which the objects move displayed? In which environment mode can you see the paths?

How can you make the object perform certain actions?

How can you add another landscape type to the terrain you already have without changing it? Perform this command.

How can you change the terrain you already have without modifying its size and borders? Perform this command. Assess the results you have.

### *Lesson 2. Filling in the gaming space*

Step1. Adding the game characters/objects

Step 2. Modeling the controlled motion of the objects

Step 3. Working with the timer

Once the paths are ready, one can add the objects. Not all the characters can move in *Kodu Game Lab*, and all moving characters have quite different movement speed.

After adding a character and setting the characteristics (color, speed), the students start the game, and observe the movement of the object. At the first step of the lesson, the object moves along the preliminarily indicated paths, so the students cannot control it.

At the second step, students begin to model the movement of the objects. According to the task, they have to work so that the characters begin moving along their paths immediately after the game starts. To do this, the user should gain the skills of modeling the conditions (“when”) under which the character must perform certain actions (“do”).

After that, the students start the game again and in the process of studying the model they find out that it is necessary to limit the time of the characters’ movement. The timer is used for this purpose in the *Kodu Game Lab*

environment. It starts at the moment the game starts, which is quite consistent with the conditions of the task. This way of controlling the movement is called "rule". When working with the model, students can set several rules for each object. After that the following questions can be offered to students for consolidation:

Which instrument helps to set the object trajectory?

How many colours can you set for a character?

Can I change the speed of the character? If so, how can it be done? What other settings can you change?

What instrument is used to program time? How to set the time, which is not defined in the corresponding menu item? Perform this command.

*Lesson 3. Adding the scorekeeper*

Step 1. Making the scoring rules for one object

Step 2. Modeling the game strategy

The timer, which was studied at the previous lesson, will help in designing the scoring system for each racer. To do this, students come up with a rule, write it in the environment language and examine the resulting model.

When the model is verified, it turns out that the racers pass a certain distance during the set time and stop, and the score changes. For example, for some characters 5 seconds are enough to reach the end of the path, turn back and start moving back. While working with the model, the students understand that this situation needs to be corrected to simplify the calculation. It may be necessary to expand the terrain in the game and increase the length of the paths. While studying the model, it may also be useful to understand that after changing the size of the game space and the path length, you can add a landscape, fences and other elements of the environment to the game. The importance of the second step is in the fact that students in practice come to the conclusion of the necessity of the score keeper as a way to determine the end of the game which can have two possible outcomes: winning and losing.

To consolidate, the following questions can be discussed:

Why should scoring be made in the program only once?

Why is it necessary to specify the colour of the path in the program of the object? Change the program so that there are two paths of the same colour. What happens to the movement model in this case?

In combination with what element of the environment can the timer become a stopwatch? What do you need to set to do this in a computer model? Perform this command.

Can you make the racers move exactly 5 seconds?

What instruments do you have to use to finish the game at a certain score? Devise your own rule and set the score value.

Are the same rule elements used in the cases when the player wins or loses in the game?

*Lesson 4. Making a dialogue with the player in the form of a test*

Step 1. Creating additional conditions for the convenience of calculations

Step 2. Holding a dialogue with the player

Step 3. Calculation of the test results

The logic of research at the first step may start with the following problem: to calculate the speed, it is necessary to know the time and the distance the object covers during this time. We have made the racers move exactly 5 seconds. But what distance do they cover during this time? To find this out, using the environment tools you have to devise a scale with divisions to calculate the distance. Then, in the process of working with the model, you have to start the game to calculate all the values on the basis of which a test for the player will be made up. After the necessary calculations are made, one can proceed with the second step –making up a test which will help to assess the achievement level of the students. When the player is ready for testing, he presses the space bar, after which the test starts. Each answer influences the total number of points, and, depending on the result, the game ends with either a victory or a defeat, and for the student this is a corresponding mark for the lesson.

The idea is to add a new object to the gaming field (revising what was learned earlier) and select (analysis, comparison, reasoning) the appropriate location. It is also necessary to consider the condition added in the previous lesson –the racers stop 5 seconds after they start to move. This fact will make it possible to make the transition from demonstration to calculation. The test starts to run immediately after the player presses a specific key (for example, the spacebar).

In order not to complicate the task, only two options can be offered to answer each question: true and false. When you click the number corresponding to the correct answer, the game adds a point to the score and offers the next question; when the wrong answer is given, one point is subtracted and the next question is offered too. It is not difficult to implement this.

The next step in the study is to refine the model so that the game responds to the player's answers in the appropriate way.

Thus, it is possible to continue an independent dialogue between the player and the game. It is useful to ask a problematic question to continue studying the model: can the same keys be used when answering different questions?

Case study:

Biker moves along the brown path. What is his speed if the distance between the red marks is 10 m and the width of each red mark is 2 m?

24.4 km/h

6.8 km/h

How many meters per second is the speed of the Plate (black path) less than the speed of the Puck (green path)?

20 m/sec

24.8 m/sec

As one can see, each new answer option should have a new key. In this case, it can be either a digit key or a letter key; the main thing is not to get mixed up when describing the reaction of the game to pressing a particular key. After the game is finished, the procedure for evaluating the test results is simulated. The students can be offered to model this stage of the task themselves. For example, the information model might look like this: if a player gets more than 101 points (or exactly 101 points), then he has answered correctly at least three questions out of five, which is a satisfactory result. The result of less than 100 points indicates that there have been two out of five correct answers at maximum. And this result is unsatisfactory, so the player has to make motion recalculations.

The following questions can be offered to consolidate the material:

- Why shouldn't the same key be assigned to several answers to different questions?
- Try to predict the actions in the game in the situation when an interval of 20-30 points is taken to evaluate the result.
- Trace this section of the program. What will happen to the score after the introduction of these lines?
- At what point does the timer start counting time? In what units is the time measured?
- What is the difference between "above" and ">=" in the "score" selector? In which cases should the item "above" be used?
- Change the colours of the paths in the computer models of all the characters. What happens in this case? Cancel the changes.
- Why is 5 seconds an optimal time interval for this game?

### Other Variants of the Game Space to Teach Computer Modeling

At present, unfortunately, schoolchildren, starting with primary school children, show a rapid decline in the interest in literary reading. To solve this problem, teachers use various non-traditional teaching technologies to improve motivation and cognitive interest in the subject (Koroleva, 2016). Introduction of software tools will be especially effective for primary school children if it is combined with play activities. Thus, modeling skills can also be obtained within the framework of a humanitarian subject course. There is an example to gamified simulation training of 2-4 grade schoolchildren by means of the game "Wise Apples" in the "Kodu Game Lab" environment.

The game is quite simple: there are two characters on the playing field, *Plate* and *Kodu*, and the player controls the movements of the latter. *Plate* flies along its own trajectory and produces apples of red and green colours at regular intervals. At the beginning of the game, the player is asked the question: "Why do you think the sea is salty?" And he is offered to read a fairy tale to answer this question. The task of the player is to collect apples, thus increasing the score, and every other ten points of the game open a new fragment of the tale.

The idea of the world "Columbus's Odyssey" can be suggested for History (Geography) lessons. The game simulates Columbus's traveling when he discovered America. The information model should simulate the activity of the Player controlling the Ship. At the beginning of the game the ship is located on the water near some island. During the game, the traveler collects the coins, following the route. When a certain amount of coins has been collected, the player gets a story about the adventures of Columbus, or a story describing some discoveries.

Biology (Environmental Studies) lessons can be accompanied by a game that involves modeling the movement of characters through a forest and its surrounding areas. Initially an object is situated in a forest surrounded by trees. Controlling the object, the player finds small nonmoving things which are randomly scattered – "garbage"

(broken branches, dry leaves, household waste). Students get information about the Red Book plants and animals after they have collected a certain amount of “garbage”.

### **Pedagogical Support of the Gamifying Educational Environment**

Having finished the work with the world designed by the teacher, the students should devise and implement their own educational project by means of the Kodu environment. The project is understood as designing and creating a computer model of the game space, developing the landscape of the world according to the plot and adding characters to it. The world is modeled for educational purposes. The main methodological problem is to come up with one's own idea of a game educational video that could be modeled. The greatest difficulties are experienced at the initial stage, when the authors have to create an image – a model of the future game world. We offer several instruction techniques to trigger creative thinking:

It is possible to take a ready-made plot and use it in a fictional world. For example, you can study the laws of Physics working on the Earth with X-Men comic book characters.

It is possible to use the plot and the game world of a fairy tale or some other literary work. For example, geometric objects can be studied while going through the twelve labors of Hercules.

Nevertheless, even after such work, some students may still experience difficulties in formulating the modeling project tasks. Therefore, the teacher should have variants of possible plots and ideas of the worlds so that the students have the right to choose.

### **Problems Connected with Assessment of the Game Space**

The next methodological problem is connected with the necessity to evaluate the modeled game world. The fact is that it is very difficult to unambiguously evaluate the creative activity, aesthetic taste, creative thinking, and imagination.

The approach offering a solution to this problem is described in the article by Soboleva and Perevozchikova (2017). The authors suggest a methodology for assessing the whole process of creating a game world from coming up with the idea of an information model of the project plot to implementing the computer model by means of the software environment. The following categories are used as criteria: idea of the game world, information model, computer model, design and educational potential.

In the context of this research, the most valuable are the criteria associated with formalizing the task (information model) and implementing the computer model by means of the environment tools.

The following criteria can be singled out in the category of “Creating an information model of objects and processes to solve the problem”: defining the goal of modeling, identifying the properties of the objects which are essential with regard to the goal of modeling, sufficiency of the objects to design the model, and description of the information model in a formalized language. Each criterion is described in [Table 1](#).

The next category is “Implementation of the computer model by means of the environment tools”; the following criteria can be taken into consideration here: efficiency of the model, implementation of certain objects and their actions through a system of rules, interactivity, and rationality. Each criterion is described in [Table 2](#).

The described variant of evaluating the game world, created to acquire the modeling skills by means of gamification, is one of the attempts to solve the methodological problem of the teacher to give an appropriate mark for creative work of the educational and cognitive character. Of course, the complexity of the plot, the multilayer character of the world may require more criteria. The value of this variant lies in the desire to offer a holistic approach (from the plot to the result), as the learning and cognitive activity in modeling starts with inventing the idea of the world, which is then formalized and implemented with the tools of the environment in the form of the game space.

Thus, the suggested approach to the structured organization of educational and cognitive activity in teaching modeling at school using the computer game technology is a reflection of the structure of students' cognitive activity and, in turn, is reflected in the structure of the lesson (lesson series) which is based on students' experimental and practical-transformational activity with information objects. It makes the basis for the accumulation of theoretical knowledge, and is focused on developing a new way of thinking, finding not just a non-standard solution but the one that is strategically verified and suitable to be applied in the real world.

Each lesson always starts with revision and includes a series of tasks and exercises that help students to establish a link between the previously studied material and the new one. They also contain questions that enhance thinking activity. The structure of each lesson consists of several steps, completing which, the students create a finished video game.



**Table 1.** Creating an Information Model of Objects and Processes to Solve the Problem

Criterion	Value	Description
Defining the goal of modeling	Low	The goal of modeling is not correctly defined
	Medium	The goal of modeling is defined correctly in general, but there is some misunderstanding in respect of the result of the problem solution (for example, restrictions on the result)
	High	The goal of modeling is correctly defined and the results of the task are clearly understood
Identifying the properties of the objects which are essential with regard to the goal of modeling	Low	There is no understanding of which properties of the given objects and phenomena are essential to achieve the goals
	Medium	Not all the properties of the objects and phenomena essential for achievement of the goals are identified
	High	All the essential properties of the objects and phenomena are identified and correctly described
Sufficiency of the objects to design the model	Low	Not all the objects and processes essential for achievement of the goals are identified
	Medium	There are more objects than necessary to design a model
	High	All the objects necessary to design a model are identified and correctly described in accordance with the task requirements
Description of the information model in a formalized language	Low	There are three gross errors: - violations in the sequence of the steps of the activity and their representation in natural language; - not all the dependencies between the original data and the result are represented; - inaccuracies in the representation of a statement or a Boolean expression
	Medium	There is one or two of the errors described above
	High	All separate steps which constitute the activity are represented as a sequence of actions in the natural language (an algorithm as a model of the activity) All dependencies between the initial data and the result of the solution of the problem are represented as a statement or a Boolean expression

**Table 2.** Implementation of the Computer Model by Means of the Environment Tools

Criterion	Value	Description
Efficiency of the model	Low	There are gross errors in the description of the model properties and characteristics of the objects by means of the environment tools.
	Medium	The program on the whole runs well, however there are some inaccuracies in the model implementation.
	High	The computer model is implemented without mistakes.
Implementation of certain objects and their actions through a system of rules	Low	The objects are added but their properties are not set. The player cannot control the movement of the object.
	Medium	The rules are only set for some objects. Some rules are incorrectly set. The range of conditions is limited to 2-3 rules.
	High	All blocks and operators, environments are reasonably used. The set of objects is optimal. Working with the rules and the timer is correctly organized. Various conditions are used. Control is transferred in a proper way.
Interactivity	Low	The user cannot influence the characters' actions and their movement.
	Medium	The user can control the game world, but his influence is limited.
	High	The model is completely interactive
Rationality	Low	The commands are in general correct, but their choice is not optimal.
	Medium	On the whole, the commands and their sequence are given correctly but some algorithms should be improved.
	High	All the commands, objects, and rules correspond to the information model and the conditions of the task.

The new methodology of the use of play technologies in teaching modeling takes into account the ways of providing the pedagogical support of the cognitive activity of students aimed at their intellectual development and implemented by means of computer educational games via improvement of information and pedagogical interaction between the participants of the educational process and organization of the cognitive activity in the course of a computer game.

## DISCUSSIONS

As the literature review has shown, modeling is both an efficient instructional method and one of the most important methods of scientific knowledge. Due to new requirements of the state and society to the education system, mastering methods of solving practice-oriented tasks involving the information resources of the society have become one of the main tasks of education. The problem solution always starts with modeling: constructing or selecting a number of models. It can be a model of the content of the problem, a model of the object, a model of the solution, or a model of the problem solution process. The use of computers and other technical means has not only enriched the didactic potential of the modeling method with regard to enhancing students' cognitive activity, but also increased the significance of information models in the scientific description of reality.

The gamification tools used in education can successfully integrate into the interactive school educational environment, and in particular in training modeling. The literature review shows that the studies on teaching modeling at school using ICT tools consider only some aspects of the problem discussed. The efficiency of using computer services and platforms is manifested in the fact that new tools enrich modern education with tools for implementing new types of educational activities and supporting the functioning of the traditional types of educational activity at a whole new level. For example, practical-transformational and experimental activity with an information object in the game space at a lesson performs a motivating role and increases the visual expression, which is important in studying abstract theoretical concepts. Employing gamification services in independent research will provide the educational and cognitive activities with the tools for consolidating knowledge in the game format, for deepening and expanding the understanding of the information object. All this can happen when you employ the technology, which is based on schoolchildren's needs. But the most important thing to remember is that the nature and content of educational and cognitive activities should not be changed.

The results of the research can be used:

- to develop the methodological system of training teachers to use the gamification tools in teaching modeling at school;
- to continue working on methodological concepts of teaching modeling as a method of educational and cognitive activity making use of other gamification tools;
- to improve the traditional teaching techniques included in the compulsory curriculum of pedagogical departments at universities.

## CONCLUSION

The tested and evaluated application of gamification platforms and services, based on the analysis and the experience of using didactic computer games, the practice of their creation, has made it possible to suggest a methodological approach to realizing the didactic potential of gamification tools in teaching modeling at school. The study has made it possible to give valuable methodological recommendations for organizing a structured lesson (a lesson series has been developed) using computer game technology. The suggested technology for the use of computer games in educational and cognitive activities in modeling:

- 1) contributes to the process of systematization and generalization of the results of previous studies on teaching modeling at school, supports the use of ICT tools to improve the quality of education;
- 2) takes into account the didactic potential of the new generation game software services and platforms: expanding the educational content; supporting individualization of learning; offering new types of educational activities; offering new tools to enhance the cognitive activity and involvement; changing the direction and quality of interaction between the participants of the educational process.

The article also describes methodological methods and recommendations for organizing information and pedagogical interaction between the participants of the educational process via educational programs on gaming platforms, both at the level of personal communication between the teacher and the student, and at the level of the tripartite teacher-student-computer interaction. These methods and recommendations can help to individualize the influence on the intellectual development of the student by means of the precise diagnosis of its condition and selective control measures.

The paper suggests recommendations regarding the logic of teaching modeling. The didactic potentialities of the use of gamification tools in teaching modeling at school to activate cognitive activity of students are described in a specific context. They are: increasing the cognitive interest; organizing the students' activity when acquiring different action modes; offering opportunities for active experimentation, implementing research and creativity elements; enhancing independence of an individual in cognition; individualizing the pedagogical guidance for the intellectual development of an individual.

Thus, the suggested methodological approach reflects the specifics of the procedure component of teaching with the use of computer educational games in the conditions of developing a new game style of thinking and recognizing the intellectual development of an individual as a priority objective in determining the strategy and tactics of education. The findings presented in the article can be of practical use for school teachers who employ computer games to teach modeling.

The research results can also be used in teaching students whose future professional activity is connected with information technologies, as gamification of educational and cognitive activities can serve as an integrative approach combining didactic potential for improving the quality of education, social integration, and providing career guidance. It is confirmed by not only the increase of motivation and involvement of students in solving modeling tasks and developing educational game projects, but also the fact that students themselves initiate research activities offering their topics of interdisciplinary projects for modeling and gamification tools to implement them.

## ACKNOWLEDGEMENT

1. The study is made within the framework of scientific project № 17-36-01026 "Improving the methodology of gamification of the educational process" supported by the Russian Foundation for Basic Research (Project director – N.L. Karavaev).
2. The work is performed according to the Russian Government Program of Competitive Growth of Kazan Federal University.

## REFERENCES

- Akwee, P. E., Toili, W. W., & Palapala, V. A. (2012). Effectiveness of computer based technology integration in teaching and learning gene concept among high school students, Kenya. *European Journal of Health and Biology Education*, 1(1), 31-52. <https://doi.org/10.20897/lectito.201203>
- Aleshchanova, I. V., Frolova, N. A., Morozova, E. V., & Zheltukhina, M. R. (2017). Psychological and Acmeological Aspect of Educational Cognitive Competence Development, in Proceedings of the 7th International Scientific and Practical Conference Current Issues of Linguistics and Didactics: The Interdisciplinary Approach in Humanities (CILDIAH 2017). *Advances in Social Science, Education and Humanities Research (ASSEHR)*, 97, 19-24.
- Aykac, V. (2015). An application regarding the availability of mind maps in visual art education based on active learning method. *Procedia – Social and Behavioral Sciences*, 174, 1859-1866. <https://doi.org/10.1016/j.sbspro.2015.01.848>
- Babintsev, V. P., Sapryka, V. A., Serkina, Ya. I., & Ushamirskaya, G. F. (2016). Reform of higher education in Russia: habitus conflict. *European Journal of Contemporary Education*, 17(3), 284-294.
- Beshenkov, S. A., Mindzaeva, E. V., Beshenkova, E. V., Shutikova, M. I., & Trubina, I. I. (2016). *Information Education in Russia*. Cham: Springer.
- Bodnar, Ch., & Clark, R. (2017). Can Game-Based Learning Enhance Engineering Communication Skills? *IEEE transactions on professional communication*, 60(1), 24-41.
- Borisenko, I. G., Yatsenko, M. P., & Chernykh, S. I. (2016). Information policy in the education system as a reflection of the society problems. *Philosophy of education*, 1(64), 51-60.
- Brull, S., & Finlayson, S. (2016). Importance of Gamification in Increasing Learning. *The Journal of Continuing Education in Nursing*, 47(8), 372-375. <https://doi.org/10.3928/00220124-20160715-09>
- Cakiroglu, U., Basibuyuk, B., & Guler, M. (2017). Gamifying an ICT course: Influences on engagement and academic performance. *Computers in human behavior*, 69, 98-107. <https://doi.org/10.1016/j.chb.2016.12.018>
- Chou, C. (2017). An Analysis of the 3D Video and Interactive Response Approach Effects on the Science Remedial Teaching for Fourth Grade Underachieving Students. *EURASIA Journal of Mathematics, Science and Technology Education*, 13(4), 1059-1073. <https://doi.org/10.12973/eurasia.2017.00658a>
- Chubik, P. S., Chuchalin, A. I., Soloviev, M. A., & Zamyatina, O. M. (2013). Training of high-class technicians and technologists. *Voprosyobrazovaniya/Educational Studies*, 2, 188-208.
- Cózar-Gutiérrez, R., & Sáez-López, J.M. (2016). Game-based learning and gamification in initial teacher training in the social sciences: an experiment with MinecraftEdu. *International Journal of Educational Technology in Higher Education*, 13, 12-24. <https://doi.org/10.1186/s41239-016-0003-4>
- Denning, P., Comer, D., Gries, D., Mulder, M., Tucker, A., Turner, J., & Young, P. (1989). Computing as a discipline. *Communications of the ACM*, 32, 1, 9-23. <https://doi.org/10.1145/63238.63239>

- Deterding, S., Kahled, R., Nacke, L., & Dixon, D. (2011). *Gamification: Toward a Definition*. Retrieved from [https://www.researchgate.net/profile/Sebastian\\_Deterding/publication/273947177\\_Gamification\\_Toward\\_a\\_definition/links/5515c8a20cf2d70ee272d21d/Gamification-Toward-a-definition.pdf](https://www.researchgate.net/profile/Sebastian_Deterding/publication/273947177_Gamification_Toward_a_definition/links/5515c8a20cf2d70ee272d21d/Gamification-Toward-a-definition.pdf)
- Dichev, Ch., & Dicheva, D. (2017). Gamifying education: what is known, what is believed and what remains uncertain: a critical review. *International journal of educational technology in higher education*, 14, 9-16. <https://doi.org/10.1186/s41239-017-0042-5>
- Duvanov, A. (1989). Robotolandia: course of Informatics for junior schoolchildren. *Informatics and Education*, 5, 37-45.
- Edwards, A., & Head, M. (2016). Introducing a culture of modeling to enhance conceptual understanding in high school chemistry courses. *Journal of Chemical Education*, 93, 1377-1382. <https://doi.org/10.1021/acs.jchemed.6b00125>
- Emerson, T. L. N., English, L., & McGoldrick, K. M. (2016). Cooperative learning and personality types. *International Review of Economics Education*, 21, 21-29. <https://doi.org/10.1016/j.iree.2015.12.003>
- Faiella, F. (2015). Gamification and learning: a review of issues and research. *Journal of e-Learning and Knowledge Society*, 11, 3-17.
- Freinet, C. (1950). *Essai de psychologie sensible appliquée à l'éducation*. Retrieved from <http://www.icem-freinet.fr/archives/educ/65-66/12-13/57.pdf>
- Galperin, P. Ya. (2005). *Lectures on Psychology*. Moscow: KDU.
- Granitskaya, A. S. (1991). *Teaching to think and act*. Moscow: Prosveshchenie.
- Grigoriev, I. S. (2016). Foreign Experience of Usage of Computer Games in Teaching Children. *Psychological Science and Education*, 8(4), 33-40.
- Hamada, M., & Hassan, M. (2017). An Interactive Learning Environment for Information and Communication Theory. *EURASIA Journal of Mathematics Science and Technology Education*, 13(1), 35-59. <https://doi.org/10.12973/eurasia.2017.00603a>
- Hasegawa, H., Shibasaki, S., & Ito, Y. (2015). Shape and Layout Understanding Method Using Brain Machine Interface for Idea Creation Support System. *Procedia Computer Science*, 60, 1205-1214. <https://doi.org/10.1016/j.procs.2015.08.183>
- Husen, T., & Tuijnman, A. (1991). The contribution of formal schooling to the increase in intellectual capital. *Educational Researcher*, 20(7), 17-25. <https://doi.org/10.3102/0013189X020007017>
- Jacobson, E. (2006). Computer homework effectiveness in developmental mathematics. *Journal of Developmental Education*, 29(3), 2-8.
- Kapp, K. M. (2007). Tools and techniques for transferring know-how from boomers to gamers. *Global Business and Organizational Excellence*, 2(5), 22-37. <https://doi.org/10.1002/joe.20162>
- Kelly, J. F. (2013). *Kodu for Kids: The Official Guide to Creating Your Own Video Games*, Que. Retrieved from [https://www.mtvernoncsd.org/cms/lib/NY01913181/Centricity/Domain/461/kodu\\_for\\_kids\\_the\\_official\\_guide\\_to\\_creating\\_your\\_own\\_video\\_games2017.pdf](https://www.mtvernoncsd.org/cms/lib/NY01913181/Centricity/Domain/461/kodu_for_kids_the_official_guide_to_creating_your_own_video_games2017.pdf)
- Kelly, P., Koates, H., & Naylor, R. (2016). Leading Online Education from Participation to Success. *Educational Studies*, 3, 34-58. <https://doi.org/10.17323/1814-9545-2016-3-34-58>
- Kholodnaya, M. A. (2015). Intelligence, creativity, learning capability: resource approach. *Psychological Journal*, 36(5), 5-14.
- Koroleva, D. O. (2016). Always online: using mobile technologies and social media at home and at school by modern teenagers. *Voprosyobrazovaniya/Educational Studies*, 1, 205-224.
- Kubiatko, M., Usak, M., Yilmaz, K., & Tasar, M. F. (2010). A cross-national study of Czech and Turkish university students' attitudes towards ICT used in science subject. *Journal of Baltic Science Education*, 9(2), 119-134.
- Kuznetsov, A. A., & Beshenkov, S. A. (2005). *Russian Educational Standards of Informatics and Informatics Technologies*. Berlin: Springer.
- Lebedeva, O., Bykova, S., Masalimova, A. R., Sokolova, N. L., & Kryukova, N. I. (2018). Peculiarities of developing high school students' lexical skills by means of the programmed learning technology. *XLinguae*, 11(1), 186-202. <https://doi.org/10.18355/XL.2018.11.01.16>
- Leontiev, D. A., Lebedeva, A. A., & Kostenko, V. Yu. (2017). Pathways of Personality Development: Following Lev Vygotsky's Guidelines. *Voprosyobrazovaniya/Educational Studies*, 2, 98-112. <https://doi.org/10.17323/1814-9545-2017-2-98-112>

- Llorens-Largo, F., Gallego-Duran, F., & Villagra-Arnedo, C. (2016). Gamification of the Learning Process: Lessons Learned. *IEEE revistaiberoamericana de tecnologías del aprendizaje-ieeeerita*, 11(4), 227-234. <https://doi.org/10.1109/RITA.2016.2619138>
- Luchenkov, A. V. (2016). Age-Oriented High School Model: Implementation Outcomes. *Voprosyobrazovaniya/Educational Studies*, 1, 191-204. <https://doi.org/10.17323/1814-9545-2016-1-191-204>
- Maloshonok, N. G. (2016). How Using the Internet and Multimedia Technology in the Learning Process Correlates with Student Engagement. *Voprosyobrazovaniya*, 4, 59-83. <https://doi.org/10.17323/1814-9545-2016-4-59-83>
- Manz, E. (2012). Understanding the codevelopment of modeling practice and ecological knowledge. *Science Education*, 96(6), 1071-1105. <https://doi.org/10.1002/sce.21030>
- Marti-Parreno, J., Mendez-Ibanez, E., & Alonso-Arroyo, A. (2016). The use of gamification in education. *Journal of computer assisted learning*, 32(6), 663-676. <https://doi.org/10.1111/jcal.12161>
- Mayer, R. V. (2016). Computer model of the empirical knowledge of physics formation: coordination with testing results. *European Journal of Contemporary Education*, 16(2), 239-247.
- Mayer, R. V. (2017). Training Modeling Based on Representation of the Meaningful Information as a System of Connected Elements. *Scientific research and development. Social and Humanitarian Research and Technology*, 2(19), 325-334.
- McVey, M. (2013). Changing spaces of education: New perspectives on the nature of learning. *International Review of Education*, 59(6), 805-807. <https://doi.org/10.1007/s11159-013-9394-9>
- Nenashev, M. I., Okulov, S. M., & Yulov, V. F. (2012). About children Intellectual Development in the Process of Studying Informatics. *Herald of Vyatka State University*, 3(3), 64-68.
- Papert, S (1980). *Mindstorms. Children, Computers, and Powerful Ideas*. Retrieved from <http://worrydream.com/r-efs/Papert%20-%20Mindstorms%201st%20ed.pdf>
- Pennington, B., & McComas, J. (2016). Effects of the good behavior game across classroom contexts. *Journal of applied behavior analysis*, 50(1), 176-180. <https://doi.org/10.1002/jaba.357>
- Polyakova, V. A., & Kozlov, O.A. (2015). Impact of gamification on information and educational environment of school. *Modern problems of science and education*, 5, 425-431.
- Potaturov, V. A. (2015). Informatization of education as a problem of culture. *Man and Culture*, 3(3), 1-40.
- Robert, I. V. (2014). Didactics in the context of informatization of education. *NauchnyiPoisk*, 2, 37-42.
- Rogoff, B., & Morelli, G. (1989). Perspectives on children's development from cultural psychology. *American Psychologist*, 44, 343-348. <https://doi.org/10.1037/0003-066X.44.2.343>
- Rozhina, V. A., & Baklashova, T. A. (2018). Teaching English language to young school-age children while making projects, playing games and using robotics. *XLinguae*, 11(1), 102-113. <https://doi.org/10.18355/XL.2018.11.01.10>
- Rubinstein, S. L. (2002). *Fundamentals of general Psychology*. St. Petersburg: Piter.
- Scanlon, E. (2010). Technology enhanced learning in science: interactions, affordances and design based research. *Journal of Interactive Media in Education*, 2, 8-19. <https://doi.org/10.5334/2010-8>
- Semenov, A. (2017). Seymour Papert and Us. Constructionism as the Educational Philosophy of the 21st Century. *Educational Studies*, 1, 269-294. <https://doi.org/10.17323/1814-9545-2017-1-269-294>
- Soboleva, E. V., Karavaev, N. L., & Perevozchikova, M. S. (2017). Improving the content of teacher training for the development and application of computer games in learning process. *Novosibirsk State Pedagogical University Bulletin*, 6, 54-70. <https://doi.org/10.15293/2226-3365.1706.04>
- Soboleva, E. V., Sokolova, A. N., Isupova, N. I., & Suvorova, T. N. (2017). Use of training programs based on gaming platforms for improving the effectiveness of education. *Novosibirsk State Pedagogical University Bulletin*, 4, 7-25. <https://doi.org/10.15293/2226-3365.1704.01>
- Soboleva, E. V., & Karavaev, N. L. (2017). Analysis of software services and platforms that have the potential for gamification of educational process. *Concept scientific and methodological electronic journal*, 8, 14-25.
- Soboleva, E. V., & Perevozchikova, M. S. (2017). The problem of evaluation of a game educational project. *Naukaibrazovanie: novoyevremya*, 5(22), 170-176.
- Sokolowski, A., Yalvac, B., & Loving, C. (2011). Science modelling in pre-calculus: How to make mathematics problems contextually meaningful. *International Journal of Mathematical Education in Science and Technology*, 42(3), 283-297. <https://doi.org/10.1080/0020739X.2010.526255>

- Su, C. (2017). The effects of students' learning anxiety and motivation on the learning achievement in the activity theory based gamified learning environment. *EURASIA Journal of mathematics, science and technology education*, 13(5), 1229-1258. <https://doi.org/10.12973/eurasia.2017.00669a>
- Trofimov, V. M. (2017). About the mathematical nature of acumen. *Novosibirsk State Pedagogical University Bulletin*, 4, 151-170. <https://doi.org/10.15293/2226-3365.1704.10>
- Tyumeneva, Yu. A., & Shklyeva, I. V. (2016). Two Approaches to the Concept of Knowledge Application: Transfer and Modeling. Overview and Criticism. *Educational Studies*, 3, 8-33. <https://doi.org/10.17323/1814-9545-2016-3-8-33>
- Ursul, A. D., & Ursul, T.A. (2015). Education for Sustainable Development: The First Results, Problems and Prospects. *Sociodynamics*, 1(1), 11-74.
- Vasenina, E. A., & Soboleva, E. V. (2013). *Interaction between the participants of the educational process in informatics in the context of information technology application*. Kirov: VyatSU.
- Vygotsky, L. S. (1999). *Thinking and speech*. Moscow: Labirint.
- Yakimanskaya, I. S. (2011). *Fundamentals of personality-oriented education*. Moscow: BINOM, Laboratoriaznaniiy.

**<http://www.ejmste.com>**



# A Study of the Effect of Implementing Intellectual Property Education with Digital Teaching on Learning Motivation and Achievements

Aimin Qi<sup>1,2\*</sup>

<sup>1</sup> Law School, Chongqing University, Chongqing, CHINA

<sup>2</sup> Director of Intellectual Property Research Center for Collaborative Innovation of Chongqing, Chongqing, CHINA

Received 18 November 2017 • Revised 3 March 2018 • Accepted 23 March 2018

## ABSTRACT

The emergence of e-learning created new education and diverse environment, conforming to the rapid change in modern society. The high acquisition characteristic breaks through the restrictions to time and space of traditional teaching, and the international emphasis on the problem and development of intellectual property is thoroughly presented on various international conferences and international conventions. The practice on education promotion could enhance the understanding of intellectual property and present the mission to practice intellectual property law, i.e. effectively transforming learners to further enhance the concept of intellectual property. Taking a university in Guangxi as the research object, total 198 students in four classes are proceeded the 16-week (3 hours per week for total 48 hours) experimental teaching study. The research results conclude the effects of 1.Digital Teaching on motivation to learn, 2.Digital Teaching on learning outcome, 3.motivation to learn on learning effect in learning outcome, and 4.motivation to learn on learning gain in learning outcome. According to the research results, suggestions are proposed, expecting to cultivate students understanding the full chain of intellectual property and realizing the property and legal norms behind intellectual property problems and the applicable approaches.

**Keywords:** digital teaching, intellectual property, motivation to learn, learning outcome

## INTRODUCTION

Under e-generation, technology has made new changes of everything and explosively changed people's living habits. Information technology is closely related to people's daily life. Along with the rapid advance of information technology, the rapid popularity of global information network has changed the operation of global organizations, and even work, lifestyles, and education are developed new appearance. People increase the acquisition of distinct Internet information and the pursuit of e-life. Under the advance of technology and the high popularity of the Internet, the far-reaching characteristic of network forms the channel for rapid information flow that the knowledge access and communication are no longer restricted to time and space. Under such space-time environment, traditional education model is led to a new level, learning activity is transferred from classrooms to virtual network environment, and learning materials are transformed from paper-based textbooks to digital contents. The emergence of e-learning creates new education and diverse environment, conforming to the rapid change in modern societies. The high acquisition characteristic breaks through the restriction to time and space of traditional teaching and creates the autonomous and individual e-learning space for easily implementing the idea of lifelong learning.

#### Contribution of this paper to the literature

- When applying intellectual property Digital Teaching, teachers should make visualized Digital Teaching processes, rather than simply projecting texts.
- When proceeding intellectual property Digital Teaching, teachers could first make a mini teaching research team to discuss the methods, aiming at the class resources and student interests.
- Teachers with intellectual property profession should develop the function of seed teachers to lead teachers with other subject background applying Digital Teaching to the material edition and practice of intellectual property education.

International emphases on the problem and development of intellectual property have been thoroughly presented on various international conferences and international conventions. The correlation lies in the acquisition of development through human thoughts, and the development path and results could be promoted by the establishment of intellectual property rules. Making intellectual property law and regulations could confirm correct behaviors and correct wrong behaviors for immediate effects. At the time when intellectual property is emphasized, the analysis and discussion of intellectual property issues could enhance the acquaintance of intellectual property and the mission to practice intellectual property in education promotion, i.e. to effectively transform learners to further enhance the intellectual property concepts and facilitate the effective and peaceful development of human society. The development of intellectual property education in a country should face the world, adapt to the requirement for globalization, and constantly update. Education circle in China therefore has to cope with the global trend, consider how to popularize intellectual property education in the society, and teach students not in the department of intellectual property understanding intellectual property. To have students understand intellectual property related systems, interpretation of intellectual property, and the practicability, as well as judicial practice, intellectual property and the policy could be applied to achieve the goal when solving the problems emerged in the development. For this reason, students should be cultivated the application of intellectual property, especially through e-learning, to enhance the sensitivity to intellectual property when facing intellectual property problems and to understand the logic behind intellectual property problems and the applicable approaches in the intellectual property problem understanding process.

## LITERATURE AND HYPOTHESIS

### Intellectual Property Education

Huang and Chuang (2016) stated that, under the conditions of commodity economy or market economy, intellectual achievement in China presented commodity and property attributes as other tangible products, like labor creation, after the economic reform and should be rewarded when being used or transferred. Lee and Hao (2015) regarded the idea of intellectual property law in China as the intellectual property norms to adjust the social relationship generated by the acquisition, use, and protection of intellectual achievement of citizens, legal people, or other organizations. Cai, Wang, and Chiang (2014) indicated that Intellectual Property Law adjusted social relationship, i.e. intellectual property relationship. It specifically referred to the social relationship which was confirmed and adjusted by intellectual property law, was induced among citizens, legal people, and other organizations based on the creation, utilization, and transfer of intellectual achievement, and had rights and obligation as the contents. Jin, Zhao, Chow, and Pecht (2014) mentioned that intellectual property education did not simply aim to cultivate excellent judges and lawyers, but to cultivate intellectual property professions with mission and justice personalities and being able to contribute to the society (Maeng & Lee, 2015). However, it has been argued whether intellectual property education is mass education or elitist education, general education or vocational education. The currently formed trend is that intellectual property education is the combination of academic education of intellectual property and professional training of intellectual property (Woo, 2014). The core is the cultivation of intellectual property education, including school education of law, formative education of judges, and education of general law.

The intellectual property education module in this study instructs students with intellectual property, which is a non-fundamental jurisprudence subject in school education of law. However, general students do not have the background of intellectual property that professional intellectual property law knowledge might be difficult to absorb for students. In this case, professional law lessons for general school education of intellectual property are not taught in this study, but the fundamental introduction to intellectual property or general lessons of law, as for students not in the department of intellectual property, is established so that students present basic concepts of intellectual property and further understand domestic and international intellectual property systems.

## Digital Teaching

Howard and Navarro (2016) pointed out distinct comprehension and interpretation of “Digital Teaching” at different development stages. It was earlier explained as “electronic teaching”, “electronic media teaching”, or “technology-oriented teaching”, as teaching various knowledge or skills through electronic media, like computers and network equipment. Later on, the so-called “online teaching”, “network teaching”, and “distance teaching” were also equivalent to Digital Teaching, but the key point was changed into teaching contents that teaching activity through the assistance of information communication technology did not simply exceed the restriction to time and space but could be continuously proceeded for diverse development, sharing, and innovation. Agarwal and Mittal (2014) regarded Digital Teaching as the process of instructors teaching with digital media, which contained Internet, Intranet, computers, satellites, broadcast, audio tapes, video tapes, interactive computers, and CDs. The application covered networking teaching, computerized teaching, virtual classrooms, and e-team teaching. Ibáñez, Serio, Villarán, and Kloos (2014) utilized the Internet as the teaching methods, including the elements of multi-format content delivery, management of teaching experience, network community for increasing learners’ exchange, and content developers or experts. Atenas and Havemann (2014) indicated that learners and instructors were no longer restricted to fixed time and location in traditional face-to-face instruction but could precede interactive teaching and learning through networks; learners could flexibly adjust the learning process according to personal learning environment and states, and instructors could adjust the teaching process, depending on learners’ situations, to develop the effect as one-to-one teaching. Jude, Kajura, and Birevu (2014) covered the research and development of e-learning tools, the establishment of network environment for e-learning and the development of digital material contents, and the design of e-learning activity in e-learning industry to reduce the barrier of time and space for instructors’ material contents, enhance knowledge and performance solutions, and provide diverse learning.

## Motivation to Learn

Clark and Mayer (2016) regarded motivation to learn as the inner psychological process to induce students’ learning activity, maintain learning activity, and lead the learning activity to the goal set by teachers. Jude, Kajura, and Birevu (2014) revealed that motivation to learn was the inner psychological process to induce students’ learning activity, maintain learning activity, and have the learning activity approach the goal set by teachers to achieve teaching goals and effective teaching of teachers. Alickovic and Subasi (2016) considered that motivation to learn was the inner belief to lead individual learning goals, induce learning behaviors and continuous efforts, reinforce cognition process, and strengthen and improve learning results. Molaee and Dortaj (2015) proposed motivation to learn as the psychological factors in encouraging students proceeding learning activity; it was the internal motive directly promoting students’ learning as well as to start and arouse learning behaviors. According to value-expectation model proposed by Huang and Chuang (2016), ability belief, expected success, and work value are the critical variables of motivation to learn in students’ self-adjusted learning process. Ability belief referred to students’ perceived personal ability when engaging in learning.

According to the research of Huang and Chuang (2016), students’ motivation to learn in this study is divided into learners’ interior motivation to learn and exterior motivation to learn, which are explained as below.

- (1) Interior orientation: The contents contain favoring challenging lessons, regarding learning as the interest and hobby, considering that learning could expand the view, being actively to learn new lessons, and regarding learning as to develop self-potential, goal fulfillment, and life value.
- (2) Exterior orientation: The contents cover that learning is to receive others’ affirmation, acquire better performance, pass examinations or evaluation, show off to others, compete with classmates, be praised and noticed by seniors or the opposite sex, avoid punishment and scolding, avoid the shame of failure, and enter ideal schools and cross levels in the future.

## Learning Outcome

Bartholomew (2015) indicated that, in a teacher’s teaching process, students’ self-affirmation to the learning ability and learning outcome were the indicators to measure the instructor’s results and teaching quality as well as the indicators of learners’ learning results. Subasi, Alickovic, and Kevric (2017) mentioned that the indicators to evaluate students’ learning results were the major items to evaluate teaching quality. Learning outcome would be affected by curriculum design, teaching methods, and learning behaviors. Students’ learning aimed to monitor self-learning, reflect the learned knowledge, and learn how to learn. Accordingly, learning outcome was the direct presentation of learning results. Students’ learning results were a major indicator to measure learning outcome as well as the major item to evaluate teaching quality (Atenas & Havemann, 2013). In this case, effectiveness aimed to test the achievement of learning or teaching goals for making timely correction or feedback as the reference or guidance to improve the next lesson. Valerie (2015) pointed out the indicators to evaluate students’ learning results

as the major items to evaluate teaching quality. Learning outcome would be affected by curriculum design, teaching methods, and learning behaviors, and students' learning aimed to monitor self-learning, reflect the learned knowledge, and learn how to learn. Learning outcome therefore was the direct presentation of learning results. Conejeros and Mansilla (2014) regarded the indicators to evaluation students' learning results as the major items to evaluate teaching quality. Learning outcome would be influenced by curriculum design, teaching methods, and learning behaviors, and students' learning was to monitor self-learning, reflect the learned knowledge, and learn how to learn so that learning results were directly presented by learning outcome.

According to Cai et al. (2014), learning outcome includes two dimensions in this study.

- (1) Learning effect - containing test performance, time for completing process, and term performance.
- (2) Learning gain - covering learning satisfaction, achievement, and preference.

Learning effect and learning gain are therefore regarded as the dimensions to measure teaching effect in this study.

## Research Hypothesis

Khalid, Khalil, and Nasreen (2014) indicated that learners presented high autonomy on e-learning management platforms to precede learning tests through the interactive function of the system and according to individual learning step and select suitable learning paths and learning contents to largely enhance the motivation to learn. Huang and Chuang (2016) stated that e-learning, according to students' individual needs and learning processes, could proceed individualized learning without being restricted to space and time and could trace the learning results to enhance learners' motivation to learn. With experimental teaching, Rawson and McCool (2014) indicated that applying good and positive teaching strategies to e-learning lessons could induce students' motivation to learn and learning interests, establish students' confidence and expression, reinforce students' problem-solving abilities, and promote teaching efficacy and learning achievement to further achieve the best e-learning effect. The following hypothesis is therefore proposed in this study.

**H1:** Digital Teaching would affect motivation to learn.

Conejeros and Mansilla (2014) mentioned that the digitalization of learning contents and learning processes was expected to enhance learning outcome with the rapid, efficient, and far-reaching characteristics. Mortara et al. (2014) argued that e-learning was regarded as a more efficient learning method because of the good accessibility, excellent adaptability, high interactivity, and self-paced. Cai et al. (2014) considered that e-learning had become a broadly used learning model, but network technology applied e-learning enhanced teaching efficiency and made up "repeated learning" which was short in traditional education; and, e-learning could effectively promote motivation to learn or learning outcome. Saelao, Tubsree, and Markwardt (2016) concluded that applying and integrating technology to teaching and learning could actually promote motivation to learn or learning outcome. Accordingly, the following hypothesis is proposed in this study.

**H2:** Digital Teaching would influence learning outcome.

Uysal and Gunal (2014) proposed that meaningful and effective learning and skillfully grasping the concepts relied on students' intrinsic psychological motivation when students expected to acquire certain knowledge with e-learning. Clark and Mayer (2016) pointed out the value of e-learning, such as receiving good performance or praise, presenting intrinsic motivation, and students being able to contact broader professional competence to enhance the learning outcome. Niknejad and Rahbar (2015) found out the positive effect of students' motivation to learn on learning outcome. Surjono (2015) mentioned that students with high motivation to learn presented more definite goals and strong desire to learn learning contents, higher expectation of results, and better self-efficacy. Alickovic and Subasi (2016) also found out better effect caused by high motivation to learn. Sanjay (2016) discovered that students with high motivation to learn showed better performance and students with intrinsic motivation outperformed those with extrinsic motivation. In this case, the following hypotheses are proposed in this study.

**H3:** Motivation to learn presents significantly positive effects on learning effect in learning outcome.

**H4:** Motivation to learn shows remarkably positive effects on learning gain in learning outcome.

## RESEARCH METHOD

### Measurement of Research Variable

#### *Motivation to learn*

Referring to Huang and Chuang (2016), motivation to learn contains two dimensions of 1. interior orientation and 2. exterior orientation.

**Table 1.** Variance analysis of Digital Teaching on motivation to learn

	Variable	F	P	Scheffe post-hoc
Digital Teaching	interior orientation	10.233	0.000*	Digital Teaching (3.96) > general teaching (3.62)
	exterior orientation	12.451	0.000*	Digital Teaching (4.22) > general teaching (3.71)

\* stands for  $p < 0.05$

**Table 2.** Variance analysis of Digital Teaching on learning outcome

	Variable	F	P	Scheffe post-hoc
Digital Teaching	learning effect	14.583	0.000*	Digital Teaching (4.06) > general teaching (3.52)
	learning gain	15.417	0.000*	Digital Teaching (4.37) > general teaching (3.87)

\* stands for  $p < 0.05$

### *Learning outcome*

Referring to Cai et al. (2014), it is divided into 1. learning effect and 2. learning gain.

### **Research Object and Sampling Data**

Taking a university in Guangxi as the research object, 198 students in 4 classes are proceeded the 16-week (3 hours a week for total 48 hours) experimental teaching research. The retrieved questionnaire is analyzed the data with SPSS, and Factor Analysis and Reliability Analysis, Regression Analysis, as well as Analysis of Variance are utilized for testing hypotheses.

### **Analysis Method**

Analysis of Variance is used in this study for discussing the difference of Digital Teaching in motivation to learn and learning outcome, and Regression Analysis is further applied to understand the relationship between motivation to learn and learning outcome.

## **ANALYSIS RESULT**

### **Reliability and Validity Analysis**

With Factor Analysis, motivation to learn is extracted two factors of "interior orientation" (eigenvalue=2.826,  $\alpha=0.81$ ) and "exterior orientation" (eigenvalue=2.247,  $\alpha=0.85$ ). The accumulative covariance explained achieves 76.283%.

Learning outcome, with Factor Analysis, is extracted two factors of "learning effect" (eigenvalue=2.182,  $\alpha=0.87$ ) and "learning gain" (eigenvalue=1.844,  $\alpha=0.88$ ). The accumulative covariance explained reaches 81.135%.

### **Effects of Teaching Methods on Motivation to Learn and Learning Outcome**

#### *Difference analysis of teaching methods in motivation to learn*

Applying Analysis of Variance to discuss the difference of teaching methods in motivation to learn, various teaching methods appear significant differences on interior orientation in motivation to learn, **Table 1**, and Digital Teaching (3.96) shows higher interior orientation than general teaching (3.62). Distinct teaching methods present remarkable differences on exterior orientation in motivation to learn, and Digital Teaching (4.22) reveals higher exterior orientation than general teaching (3.71). H1 is therefore supported.

#### *Difference analysis of teaching methods in learning outcome*

Using Analysis of Variance for discussing the difference of teaching methods in learning outcome, **Table 2**, various teaching methods show notable differences on learning effect, and Digital Teaching (4.06) reveals higher general teaching (3.52) than learning effect. Distinct teaching methods present significant differences on learning gain, and Digital Teaching (4.37) appears higher learning gain than general teaching (3.87). In this case, H2 is supported.

**Table 3.** Analysis of motivation to learn to learning outcome

Dependent variable→	Learning outcome			
Independent variable↓	Learning effect		Learning gain	
motivation to learn	β	Beta	β	Beta
interior orientation	2.046**	0.192	2.463**	0.238
exterior orientation	2.177**	0.204	2.287**	0.216
F	24.731		29.285	
Significance	0.000***		0.000***	
R2	0.238		0.267	
Adjusted R2	0.213		0.236	

Note: \* stands for  $p < 0.05$ , \*\* for  $p < 0.01$

## Correlation Analysis of Motivation to Learn and Learning Outcome

### *Correlation analysis of motivation to learn and learning effect*

To test H3, the analysis results, **Table 3**, reveal remarkable effects of interior orientation ( $\beta=2.046^{**}$ ) and exterior orientation ( $\beta=2.177^{**}$ ) on learning effect that H3 is supported.

### *Correlation analysis of motivation to learn and learning gain*

To test H4, the analysis results, **Table 3**, reveal notable effects of interior orientation ( $\beta=2.463^{**}$ ) and exterior orientation ( $\beta=2.287^{**}$ ) on learning gain that H4 is supported.

## CONCLUSION

The research findings prove that applying Digital Teaching to intellectual property education could enhance students' learning outcome and induce the motivation to learn as well as allow teachers teaching with interesting and diverse methods in classes. In addition to careful planning for the design of digital multimedia materials, intellectual property Digital Teaching materials integrating intellectual property practice and presenting teaching contents with large amount of cases and definite teaching goals would show the teaching meaning; otherwise, they might simply be funny, but ignore the learning goal and process. The design of intellectual property Digital Teaching materials should pay attention to visible factors, highlight viewing and hearing factors, reduce reading proportion, and highlight aesthetic characteristics, image, styles & preference, and art as well as graphing techniques in computers. Besides, too much stimulation of sound and light effect should be avoided, or it might result in visual fatigue and bad learning outcome to cause student attention being attracted by images and funny things but ignoring professional problems. Rich media combination could easily distract attention or be too late for dealing with information to cause cognitive burden; besides, students might pay attention to unrelated materials and pay less attention to materials which could establish the link with intellectual property concepts. For this reason, when applying Digital Teaching to intellectual property education, better and proper aesthetic images based on visualization and audibility could attract students' attention as well as focus the attention on professional contents.

## RECOMMENDATIONS

Aiming at above research results, the following suggestions are proposed in this study.

1. When applying intellectual property Digital Teaching, teachers should make visualized Digital Teaching processes, rather than simply projecting texts. Digital Teaching processes are the basic tool for Digital Teaching of law, including two elements. One is visualization to perform abstract ideas of brief introduction, key points, and systems with visualized operation. The other is audibility to include audio functions, e.g. sound effect, background music, and interpretation in the Digital Teaching process to really implement e-multimedia and avoid visual fatigue caused by single visualization.
2. Teachers are lack of the abilities of programming and animation design in the teacher training process, and professional designers and sound-effect staff do not understand intellectual property education theories, student traits, and teaching strategies. In this case, the best material design should have the match of teachers, designers, sound-effect staff, and game designers. The authorities therefore have to provide cooperation opportunities between businesses and education for instructors learning the production and



application of Digital Teaching materials to intangibly enhance the professional growth and pursue the technology and excellence of intellectual property education quality.

3. When proceeding intellectual property Digital Teaching, teachers could first make a mini teaching research team to discuss the methods, aiming at the class resources and student interests. Teachers could mutually observe and discuss in the Digital Teaching activity, review the application of Digital Teaching to intellectual property education, share individual teaching experiences, propose the difficulties in the teaching, and share the self-made teaching materials. The cooperation could induce more ideas, and sharing materials could share the burden on making materials. It could be the reference for the future application of Digital Teaching to intellectual property education.
4. A teaching team should be made for intellectual property education. Teachers with intellectual property profession should develop the function of seed teachers to lead teachers with other subject background applying Digital Teaching to the material edition and practice of intellectual property education. The information literature, course integration, and related teaching knowledge of the teacher team could be enhanced with specialty division. Besides, digital software operation guidance could be offered for the development of teaching and learning to have the application of Digital Teaching to intellectual property education be more lively and effective as well as to complement each other.

## REFERENCES

- Agarwal, B., & Mittal, N. (2014). Text classification using machine learning methods-a survey. In *Proceedings of the Second International Conference on Soft Computing for Problem Solving (SocProS 2012)*, December 28-30, 2012 (pp. 701-709). Springer, New Delhi. [https://doi.org/10.1007/978-81-322-1602-5\\_75](https://doi.org/10.1007/978-81-322-1602-5_75)
- Alickovic, E., & Subasi, A. (2016). Medical decision support system for diagnosis of heart arrhythmia using DWT and random forests classifier. *Journal of medical systems*, 40(4), 1. <https://doi.org/10.1007/s10916-016-0467-8>
- Atenas, J., & Havemann, L. (2013). Quality assurance in the open: an evaluation of OER repositories. *INNOQUAL-International Journal for Innovation and Quality in Learning*, 1(2), 22-34.
- Atenas, J., & Havemann, L. (2014). Questions of quality in repositories of open educational resources: a literature review. *Research in Learning Technology*, 22(1), 20889. <https://doi.org/10.3402/rlt.v22.20889>
- Bartholomew, S. (2015). My journey with self-directed learning. *Techniques: Connecting Education & Careers*, 90(2), 46-50.
- Cai, S., Wang, X., & Chiang, F. K. (2014). A case study of Augmented Reality simulation system application in a chemistry course. *Computers in Human Behavior*, 37, 31-40. <https://doi.org/10.1016/j.chb.2014.04.018>
- Clark, R. C., & Mayer, R. E. (2016). *E-learning and the science of instruction: Proven guidelines for consumers and designers of multimedia learning*. John Wiley & Sons. <https://doi.org/10.1002/9781119239086>
- Conejeros, A. L., & Mansilla, C. B. (2014). Evaluation of a rural self-learning English program in Chile. *Enjoy Teaching Journal*, 2(2).
- Howard, T., & Navarro, O. (2016). Critical Race Theory 20 Years Later: Where Do We Go From Here? *Urban Education*, 51(3), 253-273. <https://doi.org/10.1177/0042085915622541>
- Huang, Y. H., & Chuang, T. Y. (2016). Technology-assisted sheltered instruction: instructional streaming video in an EFL multi-purpose computer course. *Computer Assisted Language Learning*, 29(3), 618-637. <https://doi.org/10.1080/09588221.2014.1000933>
- Ibáñez, M., Serio, Á. D., Villarán, D., & Kloos, C. D. (2014). Experimenting with electromagnetism using augmented reality: Impact on flow student experience and educational effectiveness. *Computers & Education*, 71, 1-13. <https://doi.org/10.1016/j.compedu.2013.09.004>
- Jin, X., Zhao, M., Chow, T. W., & Pecht, M. (2014). Motor bearing fault diagnosis using trace ratio linear discriminant analysis. *IEEE Transactions on Industrial Electronics*, 61(5), 2441-2451. <https://doi.org/10.1109/TIE.2013.2273471>
- Jude, L. T., Kajura, M. A., & Birevu, M. P. (2014). Adoption of the SAMR Model to Asses ICT Pedagogical Adoption: A Case of Makerere University. *International Journal of e-Education, e-Business, e-Management and e-Learning*, 4(2), 106-115. <https://doi.org/10.7763/IJEEEE.2014.V4.312>
- Jude, L. T., Kajura, M. A., & Birevu, M. P. (2014). Adoption of the SAMR Model to Asses ICT Pedagogical Adoption: A Case of Makerere University. *International Journal of e-Education, e-Business, e-Management and e-Learning*, 4(2), 106-115. <https://doi.org/10.7763/IJEEEE.2014.V4.312>

- Khalid, S., Khalil, T., & Nasreen, S. (2014). A survey of feature selection and feature extraction techniques in machine learning. In *Science and Information Conference (SAI), 2014* (pp. 372-378). <https://doi.org/10.1109/SAI.2014.6918213>
- Lee, L. C., & Hao, K. C. (2015). Designing and Evaluating Digital Game-Based Learning with the ARCS Motivation Model, Humor, and Animation. *International Journal of Technology and Human Interaction, 11*(2), 80-95. <https://doi.org/10.4018/ijthi.2015040105>
- Maeng, U., & Lee S. M. (2015). EFL teachers' behavior of using motivational strategies: The case of teaching in the Korean context. *Teaching and Teacher Education, 46*, 25-36. <https://doi.org/10.1016/j.tate.2014.10.010>
- Molaei, Z., & Dortaj, F. (2015). Improving L2 Learning: An ARCS Instructional-motivational Approach. *Procedia - Social and Behavioral Sciences, 171*, 1214-1222. <https://doi.org/10.1016/j.sbspro.2015.01.234>
- Mortara, M., Catalano, C. E., Bellotti, F., Fiucci, G., Houry-Panchetti, M., & Panagiotis, P. (2014). Learning cultural heritage by serious games. *Journal of Cultural Heritage, 15*(3), 318-325. <https://doi.org/10.1016/j.culher.2013.04.004>
- Niknejad, S., & Rahbar, B. (2015). Enhancing EFL learners' reading comprehension ability through multimedia-based visualization. *Journal of Applied Linguistics and Language Research, 2*(6), 119-127.
- Rawson, C. H., & McCool, M. A. (2014). Just Like All the Other Humans? Analyzing Images of Scientists in Children's Trade Books. *School Science and Mathematics, 114*, 10-18. <https://doi.org/10.1111/ssm.12046>
- Saelao, S., Tubsree, C., & Markwardt, R. A. (2016). The effect of online language learning on the English achievement of first-year undergraduate students. *HRD JOURNAL, 6*(2), 104-116.
- Sanjay, G. (2016). A Comparative Study on Face Recognition using Subspace Analysis. In *International Conference on Computer Science and Technology Allies in Research-March* (p. 82).
- Subasi, A., Alickovic, E., & Kevric, J. (2017). Diagnosis of Chronic Kidney Disease by Using Random Forest. In *CMBEIH 2017* (pp. 589-594). Springer, Singapore. [https://doi.org/10.1007/978-981-10-4166-2\\_89](https://doi.org/10.1007/978-981-10-4166-2_89)
- Surjono, H. D. (2015). The Effects of Multimedia and Learning Style on Student Achievement in Online Electronics Course. *Turkish Online Journal of Educational Technology - TOJET, 14*(1), 116-122.
- Uysal, A. K., & Gunal, S. (2014). The impact of preprocessing on text classification. *Information Processing & Management, 50*(1), 104-112. <https://doi.org/10.1016/j.ipm.2013.08.006>
- Valerie, C. B. (2015). Self-Directed Learning and Technology. *Education Digest, 80*(6), 42-44.
- Woo, J. C. (2014). Digital Game-Based Learning Supports Student Motivation, Cognitive Success, and Performance Outcomes. *Journal of Educational Technology & Society, 17*(3), 291-307.

<http://www.ejmste.com>

# Investigating the Effects of Flipped Learning, Student Question Generation, and Instant Response Technologies on Students' Learning Motivation, Attitudes, and Engagement: A Structural Equation Modeling

Chien-Yuan Su<sup>1</sup>, Cheng-Huan Chen<sup>2\*</sup>

<sup>1</sup> Department of Curriculum and Learning Science, College of Education, Zhejiang University, Hangzhou, CHINA

<sup>2</sup> Graduate Institute of Information and Computer Education, National Taiwan Normal University, Taipei, TAIWAN

Received 4 December 2017 • Revised 13 February 2018 • Accepted 30 March 2018

## ABSTRACT

In recent years, flipped learning has grown in popularity and been more widely adopted as a mechanism of enabling active learning, which is used in different educational scenarios. This paper describes a novel extension of flipped learning by integrating student question-generation and an instant response system into the higher education curriculum and examining the impacts of this extension on students' learning motivation, attitudes, and engagement. Data were obtained from 54 sophomores at Zhejiang University, China, and the data were tested using the partial least squares structural equation modeling approach. The results indicated that this research model predicted 47.3% of the variance of learning motivation, 78.6% of the variance of attitudes toward learning, and 62.4% of the variance of learning engagement. Also, the results showed that the constructs of flipped learning and student question generation have a positive impact on the students' learning motivation, attitudes, and engagement. In contrast, though the instant response system also has a positive impact on students' engagement, it does not influence motivation or attitudes. Instructional implications and research suggestions are provided based on the results of the study.

**Keywords:** flipped learning, instant response system, structural equation modeling, student question generation

## INTRODUCTION

Flipped classroom, an alternative pedagogical approach focusing on student-centered instruction that reverses the traditional classroom environment, has recently gained much attention and has become more widely adopted in higher education. The flipped classroom approach is to "introduce students to course content outside of the classroom so that students can engage that content at a deeper level in the classroom" (Strayer, 2012, p. 171). The flipped classroom is grounded in student-centered learning, which is a set of theories and methods including constructivism, active learning, and peer-assisted learning (Bishop & Verleger, 2013). Hamdan, McKnight, McKnight, and Arfstrom (2013) also considered active learning and peer instruction as foundations of the flipped classroom. Active learning and peer instruction shift the focus and responsibility of learning from educators to students (Sohrabi & Iraj, 2016). Bergmann and Sams (2012) argued that the success of a flipped classroom is closely related to students' attitudes and engagement in learning and, to maintain or nurture their learning, teachers should provide more participation opportunities for students. However, some researchers have made comparisons between active learning in the flipped classroom versus traditional instruction, reporting similar learning gains (Davies, Dean, & Ball, 2013; Jensen, Kummer, & Godoy, 2015; Strayer, 2012). Kim, Kim, Khera, and Getman (2014) pointed out that the flipped classroom might lead to student frustration and low learning motivation if the support of students is not sufficiently structured. Yilmaz (2017) also asserts that it is important to maintain students' motivation and attitudes, describing how to engage the student in in-class activities of the course to ensure the

#### Contribution of this paper to the literature

- This study proposes an innovative flipped learning approach that integrates a student question generation strategy and instant response system for a college curriculum.
- The effects of the flipped learning strategy, student question generation, and instant response system on students' learning motivation, attitudes, and engagement were examined using partial least squares structural equation modeling.
- The flipped learning and student question generation strategies can positively affect the learning motivation, attitudes, and engagement of Chinese college students, whereas the instant response system can only positively affect the students' engagement.

efficiency of the flipped classroom. With the flipped classroom, rather than relying on a singular model, the instructor should apply multiple approaches, such as group discussion, mini-lectures for review, or student questioning (Ogden & Shambaugh, 2016).

Many proponents of active, student-centered learning suggest that flipped classroom activities should be designed to maximize the opportunities of learners to construct meaningful personal knowledge and cultivate a higher level of cognitive skills (such as applying, analyzing, and evaluating) (Hwang, Lai, & Wang, 2015) or higher-order thinking abilities (Coley, Hantla & Cobb, 2013; Mok, 2005). As such, students can determine whether they understood the course content and are able to relate it to their prior knowledge, making it their own by being able to question it in their own words (Rifai, 2010). "Students are generating their own questions" has been proven as an effective approach that could stimulate students into higher thinking and engage conceptual understanding in classroom activities (Yu, 2011). When students were involved in making decisions as to what questions were to be generated, it allowed them to better understand the subject matter (Tu & Conover, 2010). Yu (2011) further pointed out that learners need to generate questions based on material they have studied; they need to reflect on whether there are any parts of the material that seem important, but which they do not comprehend, in addition to how the core concepts can be understood. This process triggers many metacognitive processes, thus aiding learning, with learners becoming more intellectually active and engaged in the learning process (Yu, 2005, 2011). Song, Oh, and Glazewski (2017) indicated that student-generated questioning engages students with the learning topic, thereby increasing their understanding and promoting their interactions; the positive effect on student achievement has been investigated in several domains, including reading, science, and mathematics.

Strayer (2012) posits that "the regular and systematic use of interactive technology" could make the flipped classroom model unique. Some instant, interactive technologies, such as instant response systems (IRSs), can be regarded as educational facilitators because they provide not only platforms for collecting students' responses, but also support stronger communication, sharing, and socializing (Bruff, 2009; Caldwell, 2007; El-Rady, 2006; Kay & Lesage, 2009; Simpson & Oliver, 2007). IRSs can instantly tally and graphically display student responses, which can be summarized simultaneously on a classroom projector (Han & Finkelstein, 2013). By this means, every student in the classroom can express his/her thoughts instantly, and the teacher can get a rough picture of student learning progress in real-time (Chien, Lee, Li, & Chang, 2015). In recent years, numerous studies have examined the effects of IRSs in education and have reported positive learning outcomes (Caldwell, 2007; Han & Finkelstein, 2013; Kay & Lesage, 2009; Lantz, 2010; Latessa & Mouw, 2005; Moredich & Moore, 2007).

Tasks and activities incorporated in higher education teaching are based on pedagogies and supported technologies that might increase student motivation and engagement and improve their attitudes toward learning. Based on the above-cited work, this study chose flipped learning, student question generating, and the adaption of IRS as the major pedagogical approaches. This paper proposes that, if college students have more opportunities to become involved in a flipped learning activity and are encouraged to generate their own questions and to engage in deep thinking and discussion supported by using IRSs, curricula might be constructed differently. As Wang (2017) mentioned, there are only a few conceptual frameworks that can elicit 'how-to' list-associated factors with the design of an effective flipped classroom, and exactly how these factors are contributing to learning. Solutions to the issue require an understanding of what design factors entice student motivation, attitudes, and engagement in the flipped classroom environment. Therefore, this study created an innovative flipped instructional design that incorporated a flipped learning approach, student question generation (SQG), and adapted IRS into the college curriculum. The impact of these factors on college students' learning motivation, attitudes, and engagement was examined. A questionnaire was developed to evaluate the effectiveness of the approaches, and a partial least squares structural equation modeling (PLS-SEM) technique was carried out to analyze the data.

---

## LITERATURE REVIEW

### Flipped Learning

In recent years, the flipped learning model of instruction has drawn global attention. The flipped learning approach reverses the role of homework and classroom activities, with students engaged in pre-class tasks for the acquisition of knowledge, such as viewing instructional videos or doing related requirements, and furthermore is involved in practicing acquired knowledge or skills in class discussions or project work in the classroom (Chen Hsieh, Huang, & Wu, 2017). Hamdan et al. (2013) explained the key concept of the flipped learning, using the word FLIP, with the four components being a flexible learning environment, where the method is learner-centered with intentional content, and the where the teachers must have a professional knowledge and attitudes. Chi (2009) pointed out that flipped learning is an alternative to conventional pedagogy, requiring students to acquire information by viewing instructional videos ahead of physical class meetings, and allowing students to apply that knowledge in the classroom, thus engaging students in higher order active, constructive, and interactive activities. A substantial body of research has documented a variety of benefits of the flipped classroom model for teaching and learning processes in various disciplines (Abeysekera & Dawson, 2015; Bergmann & Sams, 2014; Bishop & Verleger, 2013; Chao, Chen, & Chuang, 2015; Lee, 2017; Ogden & Shambaugh, 2016; Sohrabi & Iraj, 2016; Yang, 2017). However, few studies have explored the relationships between students' learning motivation, attitudes, and engagement and the flipped learning model applied in some of China's higher education institutions.

### Student Question Generation

SQG is an essential cognitive strategy, as the act of composing questions focuses the attention of students on content and main ideas, checking whether the content is adequately comprehended (Rosenshine, Meister, & Chapman, 1996). Pizzini and Shepardson (1991) classified three types according to the cognitive level of student questions: input, processing, and output. The input-level questions demand students to recall information from sense data; the processing-level questions require students to draw relationships among the data; and the output-level questions need students to go beyond the data to hypothesize, create, and evaluate. Student questions indicate that students have thought about the presented ideas and have tried to link them with other things they know. In addition, the questions can reveal much about the quality of students' thinking and understanding (Watts, Gould, & Alsop, 1997), their confusion about various concepts (Maskill & Pedrosa de Jesus, 1997b) and reasoning (Donaldson, 1987), and what students would like to know (Harlen, Elstgeest, & Jelly, 2001). Asking students to generate questions (along with the answers) based on the learning content could help students develop skills by consciously directing their attention to the target knowledge (Yu, Chang, & Wu, 2015). Previous literature has indicated that the SQG strategy has positive effects with regard to student performance (Chin & Brown, 2002; Chin & Osborne, 2008; Ikuta & Maruno, 2005; Song et al., 2017; Yu & Wu, 2012; Yu et al., 2015; Yu, Tsai, & Wu, 2013), such as comprehension (Drake & Barlow, 2007), learning motivation (Chin & Brown, 2002; Yu et al., 2015), positive attitudes toward subject matter (Perez, 1986), more diverse and flexible thinking (Brown & Walter, 2005), problem-solving abilities (Dori & Herscovitz, 1999), and cognitive and metacognitive strategy development (Yu & Liu, 2008). However, despite the growing awareness of the benefits of using SQG in the classroom, there is little empirical research addressing the incorporation of SQG in flipped classroom activities.

### Instant Response System

IRSs, also known as clickers, student response systems or classroom response systems, are used to collect student responses in the classroom, which have gradually become an integral part of classroom interactions (Bruff, 2009; Chien et al., 2015; Cubric & Jefferies, 2015; Kay & Lesage, 2009; Penuel, Boscardin, Masyn, & Crawford, 2007). IRSs can not only be used to engage students' participation and concentration in class, but also can enrich their learning experiences, and improve teaching. Multiple studies have demonstrated the various effects of IRSs on student learning experiences in technology-enhanced classrooms across many disciplines in higher education, such as increasing students' attention (Hung, 2015; Latessa & Mouw, 2005), positive emotion and participation (Stowell & Nelson, 2007), attendance (Bullock et al., 2002; Moredich & Moore, 2007), interaction (Hung, 2015), motivation (van Dijk, van der Berg, & van Keulen, 2001), engagement and metacognition (Campbell & Mayer, 2009; Cubric & Jefferies, 2015), and improving learning performance (El-Rady, 2006). Nevertheless, Trees, and Jackson (2007) pointed out that using an IRS requires more of students' cognitive energy and collaboration, and this extended effort might not be readily accepted by students who are accustomed to relatively passive lectures. Further work is required to determine whether college students accept the additional cognitive effort that may be required when using an IRS. However, related studies tend to focus on investigating the effects of adopting an IRS on student learning via traditional lectures or by teacher questioning, while in contrast relatively little research has shown that

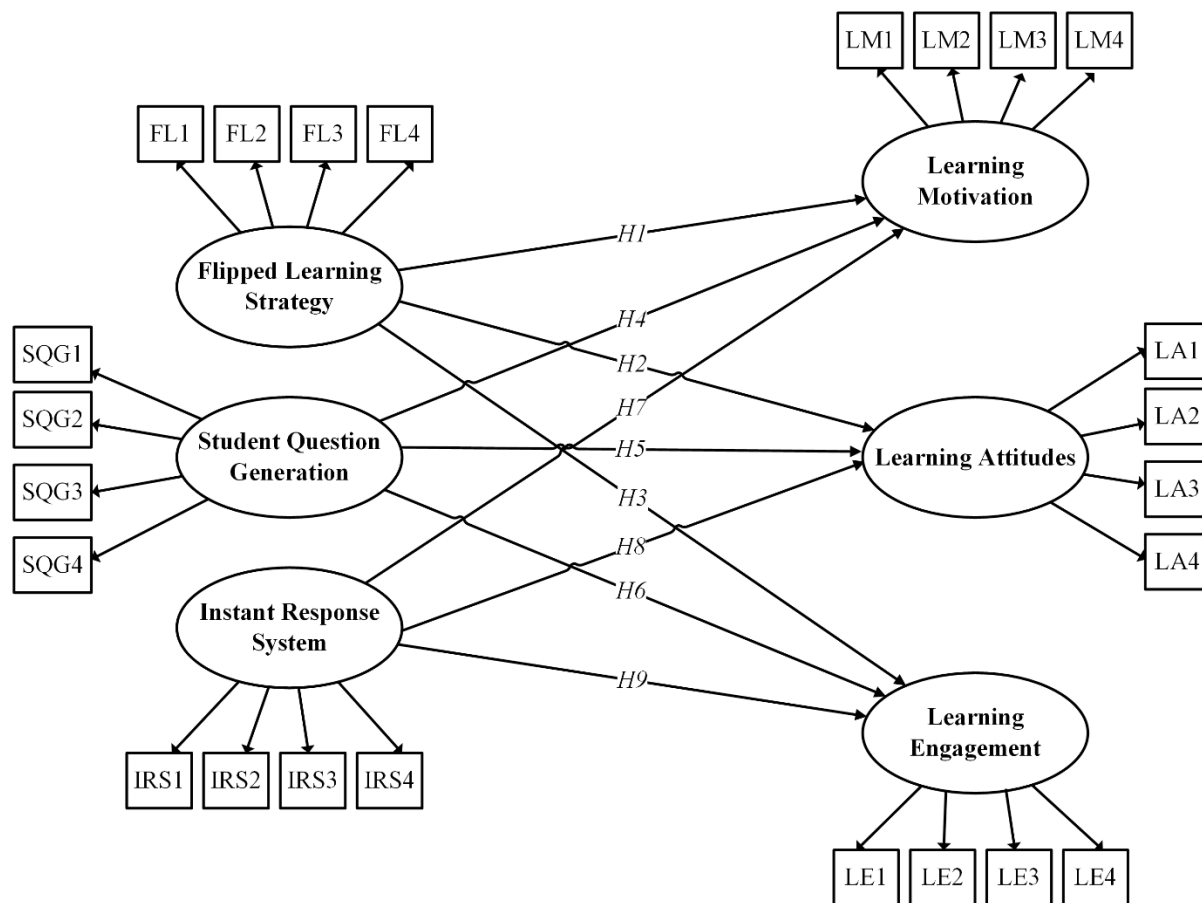


Figure 1. Research hypothesis model

IRSs increase the quantity and quality of student-centered learning (Beatty, 2005; Brewer, 2004; Kay & Lesage, 2009; Penuel et al., 2007), particularly when employed with SQG.

### RESEARCH MODEL AND HYPOTHESIS DEVELOPMENT

This study combines flipped learning strategy, SQG, and IRS into a college curriculum to investigate whether these factors have a significant impact on college students’ learning motivation, attitudes, and engagement. The proposed theoretical framework and hypotheses are depicted in Figure 1, where constructs are represented as ellipses, and observed variables are represented as rectangles. The arrows linking constructs denote the causal relationships (i.e., the hypotheses) among these, while the arrows linking constructs to observed variables symbolize measurement validity.

#### Flipped Learning Affects Students’ Learning Motivation, Attitudes, and Engagement

Compared to traditional teaching methods, positive effects on learning motivation have been reported for the flipped learning strategy (Chao et al., 2015; Chen, Wang, & Chen, 2014; Davies, Dean, & Ball, 2013; Strayer, 2012; Yilmaz, 2017), as well as on learning attitudes (Chao et al., 2015; Lin & Chen, 2016), and student engagement (Bergmann & Sams, 2014; Gilboy, Heinerichs, & Pazzaglia, 2015; Saulnier, 2015). Therefore, in line with previous research, the following hypotheses can be formulated: (H1) The flipped learning strategy has a positive impact on students’ motivation toward learning; (H2) The flipped learning strategy has a positive impact on students’ attitudes toward learning; and (H3) The flipped learning strategy has a positive impact on students’ engagement toward learning.



## Student Question Generation Affects Students' Learning Motivation, Attitudes, and Engagement

Some research has indicated that student-generated questions in the learning process have potential to guide student learning and knowledge construction (Chin & Brown, 2000; Chin & Osborne, 2008; Maskill & Pedrosa de Jesus, 1997a; Yu, 2009); facilitate their discussion and debate, thereby improving the quality of classroom discussion (Chen, Chiu, & Wu, 2012; Chin & Brown, 2002); help them to evaluate and monitor their self-understanding (Rosenshine et al., 1996); increase their learning motivation in a topic by inspiring their epistemic curiosity (Chin & Kayalvizhi, 2005; Chin & Osborne, 2008); and enhance their engagement in the course (Bates, Galloway, & McBride, 2012). Also, student-generated questions can "help create a positive attitude to classes" and benefit students "by helping them master the knowledge" (Madsen, 1983; Yu & Hung, 2006). Accordingly, the following hypotheses were proposed: (H4) SQG has a positive impact on students' motivation toward learning; (H5) SQG has a positive impact on students' attitudes toward learning; and (H6) SQG has a positive impact on students' engagement toward learning.

## Instant Response System Affects Students' Learning Motivation, Attitudes, and Engagement

A number of studies have offered quantitative and qualitative evidence of the positive effects of IRS-integrated instruction in the classroom (Caldwell, 2007; Kay & Lesage, 2009; Kennedy, Cutts, & Draper, 2006; Lantz, 2010; Simpson & Oliver, 2007). IRSs not only influence students' discussion processes and conceptual learning outcomes (Chien et al., 2015), but also have positive effects on students' emotional, motivational, and cognitive experiences in the classroom (Simpson & Oliver, 2007). In Kay and Lesage's (2009) review regarding attitudes toward IRSs, they reported that students in most previous studies had positive perceptions of the technology. Also, students are more engaged in learning and focused in classroom discussion when using an IRS (Cubric & Jefferies, 2015; Preszler, Dawe, Shuster, & Shuster, 2007; Simpson & Oliver, 2007). Therefore, this study presents the following hypotheses: (H7) IRSs have a positive impact on students' motivation toward learning; (H8) IRSs have a positive impact on students' attitudes toward learning; and (H9) IRSs have a positive impact on students' engagement toward learning.

## METHODOLOGY

### Instrument

A specific questionnaire was designed to examine students' motivation, attitudes, and engagement toward learning for a college curriculum design by combining the flipped learning strategy, SQG, and IRS. The items for the six constructs in the research model were mainly adapted from relevant items or validated instruments reported in related studies (see [Table 1](#) for the citations for each construct). The items were modified and reviewed by two university professors in China with rich teaching experience, to ensure their relevance to the flipped learning context of this study. As shown in [Table 1](#), the questionnaire consisted of 24 items to evaluate the six constructs, including the flipped learning strategy, SQG, IRS, students' learning motivation, attitudes, and engagement. Each statement was measured on a five-point Likert scale, with 1 point indicating "strongly disagree," to 5 points indicating "strongly agree."

**Table 1.** Questionnaire items used

Construct	Item	Description	Reference
Flipped learning strategy	FL1	I learned more from flipping, and I prefer the flipped class over conventional teaching.	Pierce and Fox (2012)
	FL2	I learned more by collaborating with others by sharing and commenting.	
	FL3	Flipped learning has reduced my dependency on the lecturer.	
	FL4	Flipped classroom learning has helped my personal development.	
Student question generation	SQG1	I tried to ask in-depth questions in my own words.	Yu and Wu (2012)
	SQG2	By generating questions, it can help me to think in-depth and explore the theme.	
	SQG3	I asked questions to make sure I understood the material.	
	SQG4	During the student question-generation activities, when I need to question, "I read textbooks and assigned readings over and over again."	
Instant response system	IRS1	When there are student discussions before or after answering the questions, IRS can effectively support peer instruction and discussions.	Briggs (2006); Murphy and Smark (2006)
	IRS2	IRS can increase the interactions between an instructor and the students.	
	IRS3	Using IRS can increase my participation.	
	IRS4	Using IRS can increase my class concentration.	
Learning motivation	LM1	I like the way the class is being taught.	Chang, Chung, and Huang (2016); Lin and Chen (2016)
	LM2	The way the class is taught draws my attention.	
	LM3	I have more understanding of the process involved in this curriculum.	
	LM4	I like the strengthening activity that helps me learn about the processes related to educational technology topics.	
Learning attitudes	LA1	I had to work harder in this course.	Lai and Wu (2006); Wei, Lin, and Lin (2016)
	LA2	Overall, I liked learning in this course.	
	LA3	Learning activities in this course are helpful for me.	
	LA4	I had sufficient ability to learn and comprehend the course content.	
Learning engagement	LE1	I am willing to spend more time to learn this course content well.	Hung (2015); Koballa (1988)
	LE2	I will keep my mind on listening to and looking at my teacher's or other students' explanation and demonstration.	
	LE3	I will answer the teacher's or other students' questions on my own initiative when participating in this course.	
	LE4	I can use my own initiative to collect the materials about this course content.	

## CloudClassRoom

To support student questioning and facilitate classroom interaction among students and the instructor, CloudClassRoom (CCR) (<http://www.ccr.tw>) was used in this study. CCR was developed by the Science Education Center at National Taiwan Normal University, Taiwan, and empowers teachers to initiate a series of interactive activities (e.g., exercises or peer discussion), and instantly collect or track students' learning responses in the classroom (Chien & Chang, 2015). CCR works on every Internet-capable device, without further software or plug-in installation. Using CCR, teachers and students can use textual responses to submit their content via their own devices, such as personal computers, laptops, smartphones or tablets (Chang, 2016). In this study, every student can deliver their questions instantly by CCR, and these questions can be automatically aggregated and projected in the classroom.

## Participants

The participants in the study were 54 undergraduate students from the College of Education at Zhejiang University in China. There were 16 males (29.6%) and 38 females (70.4%), and the majority (92.3%) of the participants were between 20- and 22-years-old. Convenience sampling was used in this study, and a written consent form was obtained from each of the participants before collecting data.

## Course Activity Design

This study was conducted primarily in a required introductory course, "Introduction to Educational Technology." This is a required undergraduate course in the College of Education at Zhejiang University. The activity procedure consisted of a few basic steps, as shown in Table 2. First, all students who participated formed different topic teams of five to seven with their classmates. Each team was required to prepare a different course subject report according to the textbook, as well as include an additional one-third of supplementary information to enrich the report content. In pre-class learning, the instructor provided instructional videos covering textbooks

**Table 2.** Weekly course activities

Activity type	Activity
Pre-class learning	<ul style="list-style-type: none"> <li>● Students read the theme of the textbook and access Blackboard to view course materials.</li> <li>● Each team was asked to prepare a different subject report, as well as include one-third additional supplementary information to enrich the report content.</li> </ul>
In-classroom learning	<ul style="list-style-type: none"> <li>● A team member made an oral presentation (about 50 min) related to a course topic.</li> <li>● Each student needed to generate a question by CCR.</li> <li>● A discussion focusing on questions that the students generated (about 20 min).</li> <li>● The team members attempt to answer the others' questions, and other students could express their opinions (about 20 min).</li> <li>● Teacher feedback, elaborating the different concepts and clarifying misconceptions, and supplementary micro-content (about 15 min).</li> </ul>

**Table 3.** The reliability of measures and convergent validity of the measurement model

Construct	Reliability		Convergent validity
	CR	Cronbach's $\alpha$	AVE
Flipped learning strategy	.886	.828	.660
Student question generation	.865	.797	.616
Instant response system	.872	.804	.631
Learning motivation	.879	.816	.646
Learning attitudes	.889	.832	.668
Learning engagement	.877	.813	.642

Note. CR = composite reliability; AVE = average variance extracted.

in the chosen units, and all students were required to complete pre-class text-reading and video-viewing. During the in-classroom learning activity, a team of students presented a report every week to offer details about a course subject. Other students generated their questions and sent these to the CCR using their mobile devices before the team report ended. The instructor showed these student-generated questions on the classroom's projector and helped to guide students in the class discussion. Later, the team partners attempted to answer other student-generated questions based on their understanding of the problem, and the instructor explained and elaborated upon the learning contents after the class discussion when necessary.

## Data Analysis

Data were collected on students' learning motivation, attitudes, and engagement, all measured by the self-report questionnaire. Students completed the questionnaire individually in pen-and-paper forms. This study performed the partial least squares (PLS) modeling method to analyze the data obtained from the questionnaire. PLS is a multivariate technique that is more powerful than the covariance-based structural equation modeling when dealing with small or abnormally distributed samples (Chin & Newsted, 1999; Hair, Hult, Ringle, & Sarstedt, 2017). The PLS method uses a two-stage approach, in which the first stage is to estimate the measurement model for examining both the reliability and the validity of the measurement, and the second stage is to estimate the structural model for testing the hypotheses and examining the relationships among the factors. In this study, the  $p$ -value threshold for statistical significance was set at .05. SmartPLS 3 software was used to estimate the measurement and structural models.

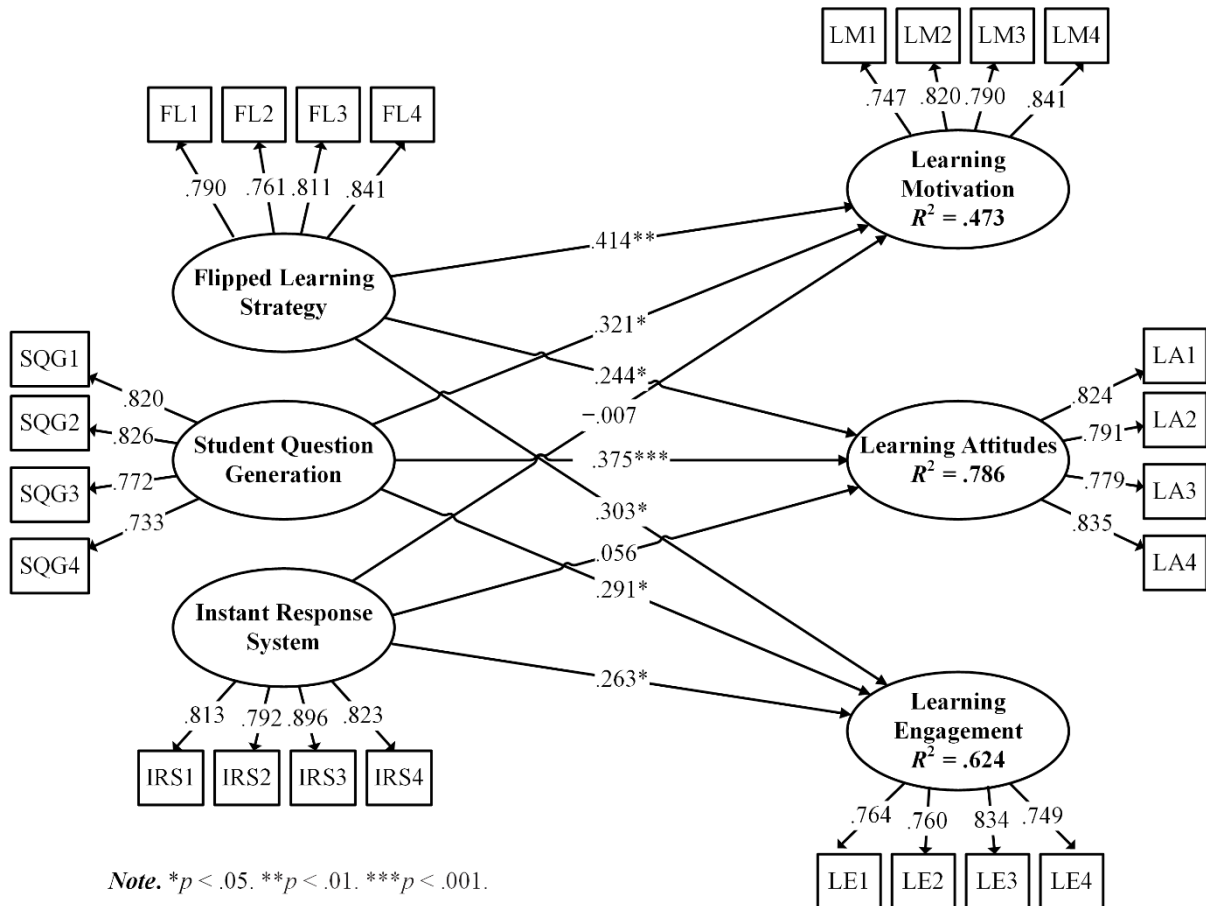
## RESULTS

### Measurement Model

This study assessed the measurement model by evaluating internal consistency reliability of measures, convergent validity, and discriminant validity. The reliability was examined using composite reliability and Cronbach's  $\alpha$ , and convergent validity was measured using average variance extracted (AVE). **Table 3** shows that the composite reliability (CR) of each construct exceeded .7; all factor loadings on their relative constructs also exceeded .7 (Hair, Tatham, Anderson, & Black, 1998); all AVE values ranged from .616 to .668, exceeding the recommended value of .5 (Hair et al., 1998). Discriminant validity was assessed by the Fornell-Larcker criterion. **Table 4** presents that all the square roots of the AVE values were greater than their relevant latent variable (i.e., construct) correlations. Therefore, the measurement model displayed an adequate internal consistency, convergent and discriminant validity (Fornell & Larcker, 1981; Hair et al., 2017).

**Table 4.** The discriminant validity of the measurement model

Construct	Discriminant validity						
	Latent variable correlations						
	1	2	3	4	5	6	
Flipped learning strategy	1	<b>.813</b>					
Student question generation	2	.778	<b>.875</b>				
Instant response system	3	.748	.779	<b>.795</b>			
Learning motivation	4	.659	.638	.559	<b>.804</b>		
Learning attitudes	5	.792	.817	.619	.756	<b>.817</b>	
Learning engagement	6	.726	.736	.522	.625	.709	<b>.801</b>



**Figure 2.** PLS path analysis results

### Structural Model

This study calculated the path coefficients, which are the coefficients linking constructs in the structural model, to serve as the indicators for the statistical significance of the hypotheses. Additionally, the  $R^2$  values (i.e., the coefficients of determination) were evaluated to understand the effectiveness of the structure model regarding its ability to explain the variations in the dependent constructs (Chin & Newsted, 1999); the values of .25, .50, and .75 for the constructs could be considered as weak, medium, and substantial, respectively (Hair et al., 2017). A bootstrapping procedure with 5,000 iterations, suggested by Hair et al., was performed to examine the statistical significance of the weights of subconstructs and the path coefficients. The values of  $R^2$  for the dependent constructs of our model showed 47.3%, 78.6%, and 62.4% of variances in learning motivation, attitudes, and engagement, respectively. Figure 2 and Table 5 show the structural relationships among constructs and the resulting values. The results rejected two hypotheses, H7 and H8, while confirming the others, H1 to H6.

**Table 5.** The hypotheses and results of the structural model

Hypothesis	Path	Path coefficient	t-value	Result
H1	Flipping learning strategy → learning motivation	.414**	2.600	support
H2	Flipping learning strategy → learning attitudes	.244*	2.572	support
H3	Flipping learning strategy → learning engagement	.303*	2.380	support
H4	Student question generation → learning motivation	.321*	2.276	support
H5	Student question generation → learning attitudes	.375***	4.204	support
H6	Student question generation → learning engagement	.291*	2.020	support
H7	Instant response system → learning motivation	-.007	0.059	not support
H8	Instant response system → learning attitudes	.056	0.728	not support
H9	Instant response system → learning engagement	.263*	2.307	support

\* $p < .05$ . \*\* $p < .01$ . \*\*\* $p < .001$ .

## DISCUSSION

According to the PLS structural analysis and hypotheses testing, this study yielded three major findings: (1) that the flipped learning strategy plays an essential role in the effect of students' learning motivation, attitudes, and engagement; (2) that SQG also has a positive effect on students' learning motivation, attitudes, and engagement; and (3) that IRS has a positive effect on students' engagement, but no positive effect on students' learning motivation and attitudes.

The first finding in this study was that the flipped learning strategy was significant in affecting the college students' learning motivation, attitudes, and engagement, aligning with prior research findings about how the flipped instruction approach can improve students' learning motivation, such as in Chao et al. (2015), Chen et al. (2014), Davies et al. (2013), Strayer (2012), and Yilmaz (2017); students held positive learning attitudes about the flipped learning strategy, which is in line with previous research (Chao et al., 2015; Lin & Chen, 2016). Also, a positive relationship between the flipped learning strategy and student engagement was detected, in accord with the findings from previous studies (Bergmann & Sams, 2014; Gilboy et al., 2015; Saulnier, 2015). The flipped approach provided the college students in China with ample opportunities to diverge from traditional teacher-directed instruction toward collaborative, student-centered learning, where students can take greater control and engage in active learning contexts. The second finding in this study was that SQG has a positive effect on college students' learning motivation, attitudes, and engagement. This result agrees with previous research, where SQG could positively affect motivation (Chin & Brown, 2002; Simpson & Oliver, 2007; Yu, 2009), attitudes (Perez, 1986; Yu & Hung, 2006; Yu & Wu, 2012), and engagement (De Jesus, Teixeira-Dias, & Watts, 2003; Pedrosa de Jesus, Neri de Souza, Teixeira-Dias, & Watts, 2005). Song et al. (2017) argued that student-generated questioning could foster students' collaborative interactions and engagement. Ikuta and Maruno (2005) also proposed that teachers should provide a classroom with more opportunities for students to comfortably express their feelings of uncertainty when any questions arise. Students could also develop deep explanations and reflections to enhance learning through answering their peers' questions in classroom discussions. Finally, the analyzed results showed that using IRS has a positive influence on students' engagement, but not on motivation or attitudes. This is also in line with findings reported in the literature (Han & Finkelstein, 2013; Song et al., 2017). The adoption of SQG with technology support may increase student engagement, foster classroom interactions and conversation among students and the teacher. However, it does not have a positive effect on students' learning motivation or attitudes. A potential reason for this lack of correlation lies in the fact that the students were already familiar with IRS. When a certain type of technology has frequently been utilized, it does not significantly affect students' learning motivation and attitudes, thus failing to generate a positive use-performance relationship (Chen Hsieh et al., 2017). On the other hand, some cognitive, emotional, and contextual factors (Berg, 2005; Volet, 2001) such as student cognitive levels, a person's belief, classroom atmosphere, teacher-student relationships, and existence within a complex interdependence that might affect students' learning motivation, attitudes or engagement, have not been considered in this study. Moreover, whether students completed reading textbooks or, conversely, viewing instructional videos in pre-class learning also needs to be further explored; a few studies (Bishop & Verleger, 2013; Heiner, Banet, & Wieman, 2014; Sohrabi & Iraj, 2016) indicated that, in general, college students do not complete reading assignments in pre-class learning. Finally, as Sohrabi and Iraj (2016) argued, the challenges of the flipped learning model include: how to successfully apply it in higher education; how to redesign college courses to dedicate in-class time to student-centered activities; and how the designed activities would help students better learn the course content. Instructors in higher education should come up with a variety of activities to incorporate theories, pedagogies, and technologies that are built to enhance student learning (Sabri, Khalid, & Li, 2016).



## CONCLUSION

This research describes a curriculum design that incorporates a flipped learning approach, SQG, and IRS into the college course, and examined their impact on students' learning motivation, attitudes, and engagement. This study found that both the flipped learning approach and student-generated questioning positively affected motivation, attitudes, and engagement. This study also found that IRS technology positively affected students' engagement, despite no significant influence on their motivation or attitudes. There are several limitations to this study that should be considered. First, this study included only the targeted students from the College of Education at Zhejiang University, China. Thus, it may be difficult to generalize the results of the study to other university students in other countries. Second, the study was conducted based on the students' general responses from the collected questionnaire. Some qualitative methods, such as unstructured interviewing and direct observation, should be used in future research. Third, this study focuses only on the flipped learning strategy, SQG, and IRS. It should be noted that different results may be obtained when combining additional or different strategies/technologies; future research might consider adding additional variables to run more levels in order to see deeper analysis and relationships related to the measurement model of this study. Strictly speaking, the use of flipped learning in China's higher education context is still in its early stages. Thus, this study provides some valuable insights that can be beneficial in explaining the potential of the flipped classroom and a combination of effective approaches and technologies in the higher education setting. The findings of the current study may assist academics, instructors, and practitioners to reach a deeper understanding from the college students' perspective.

## ACKNOWLEDGEMENTS

This research was supported by the Philosophy and Social Sciences Planning Project of Zhejiang Province, China (P.R.C.) under Grant No. 18NDJC026Z; and the teaching and scientific research project for liberal arts teachers in Zhejiang University.

## REFERENCES

- Abeyssekera, L., & Dawson, P. (2015). Motivation and cognitive load in the flipped classroom: Definition, rationale and a call for research. *Higher Education Research & Development*, 34(1), 1-14. <https://doi.org/10.1080/07294360.2014.934336>
- Bates, S. P., Galloway, R. K., & McBride, K. L. (2012). Student-generated content: Using PeerWise to enhance engagement and outcomes in introductory physics courses. In N. S. Rebello, P. V. Engelhardt, & C. Singh (Eds.), *AIP Conference Proceedings* (Vol. 1413, pp. 123-126). <https://doi.org/10.1063/1.3680009>
- Beatty, I. D. (2005). Transforming student learning with classroom communication systems. *EDUCAUSE Center for Analysis and Research*, 2004(3), 1-13.
- Berg, C. A. R. (2005). Factors related to attitude change toward learning chemistry among university students. *Chemistry Education Research and Practice*, 6(1), 1-18. <https://doi.org/10.1039/B4RP90001D>
- Bergmann, J., & Sams, A. (2012). *Flip your classroom: Reach every student in every class every day: International Society for Technology in Education* (1st ed.). Eugene, OR: International Society for Technology in Education.
- Bergmann, J., & Sams, A. (2014). *Flipped learning: Gateway to student engagement* (1st ed.). Eugene, OR: International Society for Technology in Education.
- Bishop, J. L., & Verleger, M. A. (2013, June). *The flipped classroom: A survey of the research*. Paper presented at the 120th ASEE Annual Conference & Exposition, Atlanta, GA.
- Brewer, C. A. (2004). Near real-time assessment of student learning and understanding in biology courses. *BioScience*, 54(11), 1034-1039. [https://doi.org/10.1641/0006-3568\(2004\)054\[1034:NRAOSL\]2.0.CO;2](https://doi.org/10.1641/0006-3568(2004)054[1034:NRAOSL]2.0.CO;2)
- Briggs, L. (2006, November). Response devices keep FSU students focused. *Campus Technology*, 19. Retrieved from <https://campustechnology.com/articles/2006/11/response-devices-keep-fsu-students-focused.aspx>
- Brown, S. I., & Walter, M. I. (2005). *The art of problem posing* (3rd ed.). Mahwah, NJ: Lawrence Erlbaum Associates.
- Bruff, D. (2009). *Teaching with classroom response systems: Creating active learning environments* (1st ed.). San Francisco, CA: Jossey-Bass.
- Bullock, D., LaBella, V., Clingan, T., Ding, Z., Stewart, G., & Thibado, P. (2002). Enhancing the student-instructor interaction frequency. *The Physics Teacher*, 40(9), 535-541. <https://doi.org/10.1119/1.1534821>
- Caldwell, J. E. (2007). Clickers in the large classroom: Current research and best-practice tips. *CBE – Life Sciences Education*, 6(1), 9-20. <https://doi.org/10.1187/cbe.06-12-0205>



- Campbell, J., & Mayer, R. E. (2009). Questioning as an instructional method: Does it affect learning from lectures? *Applied Cognitive Psychology*, 23(6), 747–759. <https://doi.org/10.1002/acp.1513>
- Chang, C.-Y. (2016). The marriage of interdisciplinary research: The old, the new, the borrowed, and the blue. *Journal of Science and Innovation*, 6(1), 29–39. <https://doi.org/10.6654/JSI.2016.0601.05>
- Chang, R.-C., Chung, L.-Y., & Huang, Y.-M. (2016). Developing an interactive augmented reality system as a complement to plant education and comparing its effectiveness with video learning. *Interactive Learning Environments*, 24(6), 1245–1264. <https://doi.org/10.1080/10494820.2014.982131>
- Chao, C.-Y., Chen, Y.-T., & Chuang, K.-Y. (2015). Exploring students' learning attitude and achievement in flipped learning supported computer aided design curriculum: A study in high school engineering education. *Computer Applications in Engineering Education*, 23(4), 514–526. <https://doi.org/10.1002/cae.21622>
- Chen Hsieh, J. S., Huang, Y.-M., & Wu, W.-C. V. (2017). Technological acceptance of LINE in flipped EFL oral training. *Computers in Human Behavior*, 70, 178–190. <https://doi.org/10.1016/j.chb.2016.12.066>
- Chen, C.-H., Chiu, C.-H., & Wu, C.-Y. (2012). Effects of shared note-taking and questioning review in elementary school computer classes. *Contemporary Educational Research Quarterly*, 20(2), 47–91. <https://doi.org/10.6151/CERQ.2012.2002.02>
- Chen, Y., Wang, Y., Kinshuk, & Chen, N.-S. (2014). Is FLIP enough? Or should we use the FLIPPED model instead? *Computers & Education*, 79, 16–27. <https://doi.org/10.1016/j.compedu.2014.07.004>
- Chi, M. T. H. (2009). Active-constructive-interactive: A conceptual framework for differentiating learning activities. *Topics in Cognitive Science*, 1(1), 73–105. <https://doi.org/10.1111/j.1756-8765.2008.01005.x>
- Chien, Y.-T., Chang, C.-Y. (2015). Supporting socio-scientific argumentation in the classroom through automatic group formation based on students' real-time responses. In M. S. Khine (Ed.), *Science education in East Asia* (pp. 549–563). Cham, Switzerland: Springer. [https://doi.org/10.1007/978-3-319-16390-1\\_22](https://doi.org/10.1007/978-3-319-16390-1_22)
- Chien, Y.-T., Lee, Y.-H., Li, T.-Y., & Chang, C.-Y. (2015). Examining the effects of displaying clicker voting results on high school students' voting behaviors, discussion processes, and learning outcomes. *EURASIA Journal of Mathematics, Science and Technology Education*, 11(5), 1089–1104. <https://doi.org/10.12973/eurasia.2015.1414a>
- Chin, C. & Kayalvizhi, G. (2005). What do pupils think of open science investigations? A study of Singaporean primary 6 pupils. *Educational Research*, 47(1), 107–126. <https://doi.org/10.1080/0013188042000337596>
- Chin, C., & Brown, D. E. (2000). Learning deeply in science: An analysis and reintegration of deep approaches in two case studies of grade 8 students. *Research in Science Education*, 30(2), 173–197. <https://doi.org/10.1007/BF02461627>
- Chin, C., & Brown, D. E. (2002). Student-generated questions: A meaningful aspect of learning in science. *International Journal of Science Education*, 24(5), 521–549. <https://doi.org/10.1080/09500690110095249>
- Chin, C., & Osborne, J. (2008). Students' questions: A potential resource for teaching and learning science. *Studies in Science Education*, 44(1), 1–39. <https://doi.org/10.1080/03057260701828101>
- Chin, W. W., & Newsted, P. R. (1999). Structural equation modeling analysis with small samples using partial least square. In R. Hoyle (Ed.), *Statistical strategies for small-sample research* (pp. 307–341). Thousand Oaks, CA: Sage Publications.
- Coley, K., Hantla, B., & Cobb, C. (2013, October). *Best practices for beginning a flipped classroom in the humanities*. Paper presented at the 2013 NAPCE Annual Conference, Rosemont, IL.
- Cubic, M., & Jefferies, A. (2015). The benefits and challenges of large-scale deployment of electronic voting systems: University student views from across different subject groups. *Computers & Education*, 87, 98–111. <https://doi.org/10.1016/j.compedu.2015.04.004>
- Davies, R. S., Dean, D. L., & Ball, N. (2013). Flipping the classroom and instructional technology integration in a college-level information systems spreadsheet course. *Educational Technology Research & Development*, 61(4), 563–580. <https://doi.org/10.1007/s11423-013-9305-6>
- De Jesus, H. P., Teixeira-Dias, J. J., & Watts, M. (2003). Questions of chemistry. *International Journal of Science Education*, 25(8), 1015–1034. <https://doi.org/10.1080/09500690305022>
- Donaldson, M. (1987). *Children's minds* (New ed.). New York, NY: Harper Perennial.
- Dori, Y. J., & Herscovitz, O. (1999). Question-posing capability as an alternative evaluation method: Analysis of an environmental case study. *Journal of Research in Science Teaching*, 36(4), 411–430. [https://doi.org/10.1002/\(SICI\)1098-2736\(199904\)36:4<411::AID-TEA2>3.0.CO;2-E](https://doi.org/10.1002/(SICI)1098-2736(199904)36:4<411::AID-TEA2>3.0.CO;2-E)
- Drake, J. M., & Barlow, A. T. (2007). Assessing students' levels of understanding multiplication through problem writing. *Teaching Children Mathematics*, 14(5), 272–277.

- El-Rady, J. (2006). To click or not to click: That's the question. *Innovate: Journal of online education*, 2(4), Article 6.
- Fornell, C., & Larcker, D. F. (1981). Evaluating structural equation models with unobservable variables and measurement error. *Journal of Marketing Research*, 18(1), 39–50. <https://doi.org/10.2307/3151312>
- Gilboy, M. B., Heinerichs, S., & Pazzaglia, G. (2015). Enhancing student engagement using the flipped classroom. *Journal of nutrition education and behavior*, 47(1), 109–114. <https://doi.org/10.1016/j.jneb.2014.08.008>
- Hair, J. F., Jr., Hult, G. T. M., Ringle, C. M., & Sarstedt, M. (2017). *A primer on partial least squares structural equation modeling (PLS-SEM)* (2nd ed.). Thousand Oaks, CA: Sage Publications.
- Hair, J. F., Jr., Tatham, R. L., Anderson, R. E., & Black, W. (1998). *Multivariate data analysis* (5th ed.). Upper Saddle River, NJ: Prentice Hall.
- Hamdan, N., McKnight, P., McKnight, K., & Arfstrom, K. M. (2013). *The flipped learning model: A white paper based on the literature review titled a review of flipped learning*. Arlington, VA: Flipped Learning Network. Retrieved from [https://flippedlearning.org/wp-content/uploads/2016/07/WhitePaper\\_FlippedLearning.pdf](https://flippedlearning.org/wp-content/uploads/2016/07/WhitePaper_FlippedLearning.pdf)
- Han, J. H., & Finkelstein, A. (2013). Understanding the effects of professors' pedagogical development with Clicker Assessment and Feedback technologies and the impact on students' engagement and learning in higher education. *Computers & Education*, 65, 64–76. <https://doi.org/10.1016/j.compedu.2013.02.002>
- Harlen, W., Elstgeest, J., & Jelly, S. (2001). *Primary science: Taking the plunge* (2nd ed.). London, England: Heinemann.
- Heiner, C. E., Banet, A. I., & Wieman, C. (2014). Preparing students for class: How to get 80% of students reading the textbook before class. *American Journal of Physics*, 82(10), 989–996. <https://doi.org/10.1119/1.4895008>
- Hung, H.-T. (2015). Flipping the classroom for English language learners to foster active learning. *Computer Assisted Language Learning*, 28(1), 81–96. <https://doi.org/10.1080/09588221.2014.967701>
- Hwang, G.-J., Lai, C.-L., & Wang, S.-Y. (2015). Seamless flipped learning: A mobile technology-enhanced flipped classroom with effective learning strategies. *Journal of Computers in Education*, 2(4), 449–473. <https://doi.org/10.1007/s40692-015-0043-0>
- Ikuta, J., & Maruno, S. (2005). Student question generation in the classroom: A review. *Kyushu University Psychological Research*, 6, 37–48. <https://doi.org/10.15017/15680>
- Jensen, J. L., Kummer, T. A., & Godoy, P. D. d. M. (2015). Improvements from a flipped classroom may simply be the fruits of active learning. *CBE – Life Sciences Education*, 14, 1–12. <https://doi.org/10.1187/cbe.14-08-0129>
- Kay, R. H., & Lesage, A. (2009). Examining the benefits and challenges of using audience response systems: A review of the literature. *Computers & Education*, 53(3), 819–827. <https://doi.org/10.1016/j.compedu.2009.05.001>
- Kennedy, G., Cutts, Q., & Draper, S. W. (2006). Evaluating electronic voting systems in lectures: Two innovative methods. In D. A. Banks (Ed.), *Audience response systems in higher education*. Hershey, PA: Information Science Publishing. <https://doi.org/10.4018/978-1-59140-947-2.ch011>
- Kim, M. K., Kim, S. M., Khera, O., & Getman, J. (2014). The experience of three flipped classrooms in an urban university: An exploration of design principles. *The Internet and Higher Education*, 22, 37–50. <https://doi.org/10.1016/j.iheduc.2014.04.003>
- Koballa, T. R., Jr. (1988). Attitude and related concepts in science education. *Science Education*, 72(2), 115–126. <https://doi.org/10.1002/sce.3730720202>
- Lai, C.-Y., & Wu, C.-C. (2006). Using handhelds in a Jigsaw cooperative learning environment. *Journal of Computer Assisted Learning*, 22(4), 284–297. <https://doi.org/10.1111/j.1365-2729.2006.00176.x>
- Lantz, M. E. (2010). The use of 'Clickers' in the classroom: Teaching innovation or merely an amusing novelty? *Computers in Human Behavior*, 26(4), 556–561. <https://doi.org/10.1016/j.chb.2010.02.014>
- Latessa, R., & Mouw, D. (2005). Use of an audience response system to augment interactive learning. *Family Medicine*, 37(1), 12–14.
- Lee, B. (2017). TELL us ESP in a flipped classroom. *EURASIA Journal of Mathematics, Science and Technology Education*, 13(8), 4995–5007. <https://doi.org/10.12973/eurasia.2017.00978a>
- Lin, P.-C., & Chen, H.-M. (2016). The effects of flipped classroom on learning effectiveness: using learning satisfaction as the mediator. *World Transactions on Engineering and Technology Education*, 14(2), 231–244.
- Madsen, H. S. (1983). *Techniques in Testing* (1st ed.) New York, NY: Oxford University Press.
- Maskill, R., & Pedrosa de Jesus, H. (1997a). Asking model questions. *Education in Chemistry*, 34(5), 132–134.
- Maskill, R., & Pedrosa de Jesus, H. (1997b). Pupils' questions, alternative frameworks and the design of science teaching. *International Journal of Science Education*, 19(7), 781–799. <https://doi.org/10.1080/0950069970190704>

- Mok, M. M. C. (2005, December). *A conceptual framework for the design of web-based self-directed learning curriculum*. Paper presented at the 2005 International Conference on Education and Information Technology, Keelung, Taiwan.
- Moredich, C., & Moore, E. (2007). Engaging students through the use of classroom response systems. *Nurse Educator*, 32(3), 113–116. <https://doi.org/10.1097/01.NNE.0000270225.76661.74>
- Murphy, B., & Smark, C. J. (2006). Convergence of learning experiences for first year tertiary commerce students—Are personal response systems the meeting point? *The Journal of American Academy of Business, Cambridge*, 10(1), 186–191.
- Ogden, L., & Shambaugh, N. (2016). Best teaching and technology practices for the hybrid flipped college classroom. In P. Vu, S. Fredrickson, & C. Moore (Eds.), *Handbook of research on innovative pedagogies and technologies for online learning in higher education* (pp. 281–303). Hershey, PA: IGI Global. <https://doi.org/10.4018/978-1-5225-1851-8.ch013>
- Pedrosa de Jesus, H., Neri de Souza, F., Teixeira-Dias, J. J. C., & Watts, M. (2005). Organising the chemistry of question-based learning: A case study. *Research in Science & Technological Education*, 23(2), 179–193. <https://doi.org/10.1080/02635140500266419>
- Penuel, W. R., Boscardin, C. K., Masyn, K., & Crawford, V. M. (2007). Teaching with student response systems in elementary and secondary education settings: A survey study. *Educational Technology Research and Development*, 55(4), 315–346. <https://doi.org/10.1007/s11423-006-9023-4>
- Perez, J. A. (1986). *Effects of student-generated problems on problem solving performance*. Unpublished doctoral dissertation, Teachers College, Columbia University, New York, NY.
- Pierce, R., & Fox, J. (2012). Vodcasts and active-learning exercises in a “flipped classroom” model of a renal pharmacotherapy module. *American Journal of Pharmaceutical Education*, 76(10), Article 196. <https://doi.org/10.5688/ajpe7610196>
- Pizzini, E. L., & Shepardson, D. P. (1991). Student questioning in the presence of the teacher during problem solving in science. *School Science and Mathematics*, 91(8), 348–352. <https://doi.org/10.1111/j.1949-8594.1991.tb12118.x>
- Preszler, R. W., Dawe, A., Shuster, C. B., & Shuster, M. (2007). Assessment of the effects of student response systems on student learning and attitudes over a broad range of biology courses. *CBE – Life Sciences Education*, 6(1), 29–41. <https://doi.org/10.1187/cbe.06-09-0190>
- Rifai, N. A. (2010). Attitude, motivation, and difficulties involved in learning the English language and factors that affect motivation in learning it. *Procedia - Social and Behavioral Sciences*, 2(2), 5216–5227. <https://doi.org/10.1016/j.sbspro.2010.03.849>
- Rosenshine, B., Meister, C., & Chapman, S. (1996). Teaching students to generate questions: A review of the intervention studies. *Review of Educational Research*, 66(2), 181–221. <https://doi.org/10.3102/00346543066002181>
- Sabri, M., Khalid, F. K., & Li, L. K. (2016). Assessing students engagement in an online student question-generation activity towards their learning motivation. *International Journal of Languages, Literature and Linguistics*, 2(1), 23–31. <https://doi.org/10.18178/IJLLL.2016.2.1.62>
- Saulnier, B. (2015). The flipped classroom in systems analysis & design: Leveraging technology to increase student engagement. *Information Systems Education Journal*, 13(4), 33–40.
- Simpson, V., & Oliver, M. (2007). Electronic voting systems for lectures then and now: A comparison of research and practice. *Australasian Journal of Educational Technology*, 23(2), 187–208. <https://doi.org/10.14742/ajet.1264>
- Sohrabi, B., & Iraj, H. (2016). Implementing flipped classroom using digital media: A comparison of two demographically different groups perceptions. *Computers in Human Behavior*, 60, 514–524. <https://doi.org/10.1016/j.chb.2016.02.056>
- Song, D., Oh, E. Y., & Glazewski, K. (2017). Student-generated questioning activity in second language courses using a customized personal response system: A case study. *Educational Technology Research and Development*, 65(6), 1425–1449. <https://doi.org/10.1007/s11423-017-9520-7>
- Stowell, J. R., & Nelson, J. M. (2007). Benefits of electronic audience response systems on student participation, learning, and emotion. *Teaching of Psychology*, 34(4), 253–258. <https://doi.org/10.1080/00986280701700391>
- Strayer, J. F. (2012). How learning in an inverted classroom influences cooperation, innovation and task orientation. *Learning Environments Research*, 15(2), 171–193. <https://doi.org/10.1007/s10984-012-9108-4>

- Trees, A. R., & Jackson, M. H. (2007). The learning environment in clicker classrooms: Student processes of learning and involvement in large university-level courses using student response systems. *Learning, Media and Technology*, 32(1), 21–40. <https://doi.org/10.1080/17439880601141179>
- Tu, K., & Conover, G. (2010, January). *Student participation in question generation*. Poster session presented at the 2010 Health Professions Educational Research Symposium, Fort Lauderdale, FL.
- van Dijk, L. A., van der Berg, G. C., & van Keulen, H. (2001). Interactive lectures in engineering education. *European Journal of Engineering Education*, 26(1), 15–28. <https://doi.org/10.1080/03043790123124>
- Volet, S. (2001). Understanding learning and motivation in context: A multi-dimensional and multi-level cognitive-situative perspective. In S. Volet & S. Järvelä (Eds.), *Motivation in learning contexts: Theoretical advances and methodological implications* (pp. 57–82). Elmsford, NY: Pergamon Press.
- Wang, F. H. (2017). An exploration of online behaviour engagement and achievement in flipped classroom supported by learning management system. *Computers & Education*, 114, 79–91. <https://doi.org/10.1016/j.compedu.2017.06.012>
- Watts, M., Gould, G., & Alsop, S. (1997). Questions of understanding: Categorising pupils' questions in science. *School Science Review*, 79(286), 57–63.
- Wei, C.-W., Lin, Y.-C., & Lin, Y.-T. (2016). An interactive diagnosis approach for supporting clinical nursing courses. *Interactive Learning Environments*, 24(8), 1795–1811. <https://doi.org/10.1080/10494820.2015.1057741>
- Yang, C. C. R. (2017). An investigation of the use of the 'flipped classroom' pedagogy in secondary English language classrooms. *Journal of Information Technology Education: Innovations in Practice*, 16, 1–20. <https://doi.org/10.28945/3635>
- Yilmaz, R. (2017). Exploring the role of e-learning readiness on student satisfaction and motivation in flipped classroom. *Computers in Human Behavior*, 70, 251–260. <https://doi.org/10.1016/j.chb.2016.12.085>
- Yu, F.-Y. (2005). Promoting metacognitive strategy development through online question-generation instructional approach. In C.-K. Looi, D. Jonassen, & M. Ikeda (Eds.), *Towards sustainable and scalable educational innovations informed by the learning sciences* (pp. 564–571). Amsterdam, The Netherlands: IOS Press.
- Yu, F.-Y. (2009). Scaffolding student-generated questions: Design and development of a customizable online learning system. *Computers in Human Behavior*, 25(5), 1129–1138. <https://doi.org/10.1016/j.chb.2009.05.002>
- Yu, F.-Y. (2011). Multiple peer-assessment modes to augment online student question-generation processes. *Computers & Education*, 56(2), 484–494. <https://doi.org/10.1016/j.compedu.2010.08.025>
- Yu, F.-Y., & Hung, C.-C. (2006). An empirical analysis of online multiple-choice question-generation learning activity for the enhancement of students' cognitive strategy development while learning science. In T. Simos & G. Maroulis (Series Eds.), *Lecture Series on Computer and Computational Sciences: Vol. 7A. Recent progress in computational sciences and engineering* (pp. 585–588). Boca Raton, FL: CRC Press.
- Yu, F.-Y., & Liu, Y.-H. (2008). The comparative effects of student question-posing and question-answering strategies on promoting college students' academic achievement, cognitive and metacognitive strategies use. *Journal of Education & Psychology*, 31(3), 25–52.
- Yu, F.-Y., & Wu, C.-P. (2012). Student question-generation: The learning processes involved and their relationships with students' perceived value. *Journal of Research in Education Sciences*, 57(4), 135–162. <https://doi.org/10.3966/2073753X2012125704005>
- Yu, F.-Y., Chang, Y.-L., & Wu, H.-L. (2015). The effects of an online student question-generation strategy on elementary school student English learning. *Research and Practice in Technology Enhanced Learning*, 10(1), Article 24. <https://doi.org/10.1186/s41039-015-0023-z>
- Yu, F.-Y., Tsai, H.-C., & Wu, H.-L. (2013). Effects of online procedural scaffolds and the timing of scaffolding provision on elementary Taiwanese students' question-generation in a science class. *Australasian Journal of Educational Technology*, 29(3), 416–433. <https://doi.org/10.14742/ajet.197>

<http://www.ejmste.com>



## Discussing the Effect of Service Innovation on Customer Satisfaction Based on Statistics Education – A Case on Qianjiangyue Leisure Farm

Shui-Sheng Fan<sup>1</sup>, You-Cheng Chen<sup>1\*</sup>, Lu Miao<sup>1</sup>

<sup>1</sup> Anxi College of Tea Science, Fujian Agriculture and Forestry University, Anxi County, Fujian Province, CHINA

Received 27 December 2017 • Revised 3 March 2018 • Accepted 23 March 2018

### ABSTRACT

Service innovation has been constantly emphasized domestically and internationally. The factors of globalization, changing lifestyles, and the transfer of industrial focus indirectly create business opportunities for leisure farms. To attract more customers for surpassing competitors, the cultivated service innovation capability must present uniqueness and match with customer needs. Based on statistics education, this study intends to discuss the effect of leisure farms' service innovation on customer satisfaction. Employees of Qianjiangyue Leisure Farm, as the research samples, are distributed 330 copies of questionnaire. Total 278 valid copies are retrieved, with the retrieval rate 84%. The research results conclude significant correlations between 1.service innovation and customer satisfaction, 2.statistics education and service innovation, and 3.statistics education and customer satisfaction. According to the results, suggestions are proposed, expecting to assist leisure farms in service innovation and the promotion of customer satisfaction.

**Keywords:** statistics education, leisure farm, service innovation, customer satisfaction

### INTRODUCTION

The public has stressed more on the quality of life in past years. The popularity of national tourism obviously increases the expenditure on tourism. People can easily acquire sufficient information of tourism and are favor of more characteristic and innovative locations and methods. Besides, the government positively marketing tourism has largely increased the demands that leisure farms are flourishing. Nevertheless, lots of unique and novel business opportunities have been derived in various industries. In face of the trend and challenge of merchandizing products and services, enterprises have to develop competition patterns different from the past. Leaders therefore cannot satisfy with current situations, but should constantly pursue innovation to reduce costs or enhance services. Positively improving existing products or services and even constantly developing new products or service could largely enhance customer satisfaction with such products or services. Service industry has gradually become the key branch of economy in various countries to come out with the idea of service innovation.

The focus of service lies in consumers' constantly updating experience, and enterprises have to provide better services to attract and satisfy consumers. The diverse consumer needs advance the development of service innovation. Such changes also result in distinct challenges for leisure farms. Leisure farms regard the quality of service as the basis, aiming to have the services and equipment achieve certain standard and promote the quality up to the same as international level. Nonetheless, a lot of industries do not simply pursue service quality, but regard service innovation as the goal at the next stage and enhance the competitiveness and surpass competitors through innovative strategies. Apparently, service innovation is relatively important for leisure farms. Based on statistics education, this study intends to discuss the effect of leisure farms' service innovation on customer satisfaction.

#### **Contribution of this paper to the literature**

- The sensitivity to statistical data should be reinforced in the statistics education so that leisure farms do not simply acquire the comprehensive statistical index, but discover key factors in customer satisfaction through statistical analyses in order to enhance customer satisfaction.
- Products and services offered by leisure farms are easily imitated by others in the same industry, as it is transparent and cannot be regulated with patents.
- To understand customer satisfaction with leisure farms, some businesses would request customers filling in satisfaction survey or directly inquire customers' satisfaction to acquire customers' true needs through statistical data.

## **LITERATURE REVIEW**

### **Service Innovation**

Tseng and Lee (2014) mentioned that everyone had the experience in service innovation, which could be driven by technology to widen the service coverage and reduce service costs; in other words, whatever different from the original forms could be regarded as new service. There were several types of service innovation. For instance, service staff in an airplane or a restaurant could better understand customer needs or preference. Cox (2013) pointed out service innovation as enterprises enhancing the product or service value to cope with customer needs for diverse products and services. In this case, market needs were the major factor in service innovation to correspond to the international development trend of Taiwan. Namkung and Jang (2013) proposed the definition of innovation as the behavior creating wealth with resources; as long as an organization being able to create value with existing resources, it was regarded as innovation. Innovation was the purposive and regular activity and could create higher added value; innovation did not necessarily involve in technology and might even not require a physical object. It was also considered that most successful innovation was achieved through changes to create novel and different value and satisfaction. Josiam and Henry (2014) explained service innovation as enterprises promoting the product or service value to cope with customer needs for diverse products and services, and market needs were the major factor in service innovation to correspond to the development trend of international industries faced by Taiwan. Armstrong and Kotler (2014) proposed that catering to different demands of time background and competition methods could help enterprises' business competition, keep with the time, and develop. Successful service innovation was achieved by listening to customers and understanding the needs. Solomon and Michael (2014) considered that innovation aimed to enhance market competitiveness in order to understand customer needs, improve existing service model, and eventually achieve targeted revenue and profits. Gremyr et al. (2014) indicated that service innovation was essentially the new services offered by enterprises for customers, i.e. customers as a part of service innovation. The major difference in service innovation between service innovation and traditional operation innovation did not simply involve in enterprises.

Referring to the most representative "three dimensions of service innovation" proposed by Ho and Ganesan (2013) for measuring enterprises' competitiveness, the model analyzes various patterns of service innovation.

- (1) Service concept: Service innovation could be delivered to customers through various tangible and intangible services, which were apparent (e.g. holiday banks) but often intangible and abstract, and a feeling or special agreement (e.g. concepts, ideas, and problem-solving methods).
- (2) Customer interface: Customer interface refers to transforming marketing processes into the interaction of continuous dialogues with customers to rapidly respond to customer needs, present tight connection with customers in the information exchange and interaction processes, and further enhance the relationship between enterprises and customers.
- (3) Service delivery: Intangible output of service should be delivered to customers through delicate service delivery system design.

### **Statistics Education**

Rosell, Lakemond, and Wasti (2014) mentioned that a modern person, in the information explosion society, should present the capability of "sorting and compressing large amount of information into simple and understandable patterns". Among various data arrangement methods, "statistics" was simple and convenient. Statistics explained the essence of various social or natural phenomena through described data which were organized and analyzed for understanding the meaning. The statistical process contains four points of data collection, data organization and analysis, data characterization, and data explanation. Aziz and Omar (2013)



indicated that statistics education aimed to find out the information implied in data through analyses and organization to explain certain phenomenon or make prediction. Trigo (2013) mentioned that a complete statistics teaching should contain dynamic activity for students' participation to develop the required insight or enhance the level of understanding from data collection. In this case, the curriculum design of statistics was a series of processes dealing with a real problem, including problem formation, data collection, and data sorting, calculation, presentation, and explanation. Batnasan (2014) described that statistics education was used for dealing with data, which were composed of numbers; but, it was not simply numbers, but numbers with contents. In this case, statistics found out information from data and make conclusions. Farias, Aguiar, and Melo (2014) indicated that current curriculum design of statistics education, i.e. data analysis process at various stages, contained the important processes of (1) observing the characteristics of all types of data, (2) integrating and calculating data, and (3) analyzing, presenting, and explaining data results. Stickdorn and Schneider (2013) considered that teaching activity of statistics education covered data collection, organization, analysis, presentation, and explanation, aiming to achieve the following points. (1) Selecting suitable data collection model, according to the classification of problems and data, to solve problems. (2) Cultivating the basic critical thinking habit and capability in the data analysis process. (3) Developing the capability of interpreting and producing charts and tables with distinct representation for communication. (4) Comprehending and grasping the meaning of information.

Referring to Kang and Kang (2014), the statistical literacy model contains knowledge elements and dispositional elements

- (1) Knowledge elements include elements of literacy skills, statistical knowledge, mathematical knowledge, context knowledge, and critical questions.
- (2) Dispositional elements cover two elements of beliefs & attitudes and critical stance

### **Customer Satisfaction**

The research of Jeong, Jang, Day, and Ha (2014) on consumer satisfaction induced successive researchers' definitions of customer satisfaction. Cardozo applied satisfaction to consumers and marketing and indicated that customer satisfaction would enhance the repurchase behavior of customers and the purchase of other products. Salunke, Weerawardena, and McColl-Kennedy (2013) considered that consumer satisfaction was resulted from the degree of delight or disappointment after comparing the expected product before purchase and the perceived product functions and characteristics after purchase. When the product functions and characteristics were not as expected, consumers would be dissatisfied; while they would be satisfied when the functions and characteristics exceeded the expectation. Batnasan (2014) explained customer satisfaction as customers' overall attitudes after consumption to reflect the degree of like or dislike. Kindström, Kowalkowski, and Sandberg (2013) pointed out the factors in customer satisfaction as customer being satisfied with products or services reaching the demanded and expected evaluation, which would be affected by the characteristics and quality of specific products or services in which personal and situational factors were also mixed. Grimaldi, Quinto, and Rippa (2013) pointed out customer satisfaction as the relative judgment which took customers' acquisition and benefits from the purchase as well as the costs and efforts for the purchase into account. Tsai and Hsu (2014) mentioned that customer satisfaction was caused by the comparison between customers' pre-expectation of products or services through past purchase experiences and the current purchase experience. Zhang and Wu (2013) regarded it as the attitude formed after the consumption process and the evaluation after purchasing products or receiving services to reflect the degree of customers' like and dislike about the consumption. Gomez and Ballard (2013) explained it as the comparison between customers' pre-expectation of products or services through past purchase experiences and the current purchase experience.

Referring to Tang (2013), customer satisfaction is divided into

- (1) Employee evaluation: Customers' satisfaction with the direct service staff, including professional knowledge and friendliness.
- (2) Merchandise valuation: Customer satisfaction with products, containing availability and freshness.

### **Research Hypothesis**

Taking consumers with purchase experiences in retail service industry as the research object, Yan, Wang, and Chau (2013) discussed the effect of service innovation drive and innovation patterns on performance. From the viewpoint of service dominant logic, the analysis results revealed that the mediation effect of "incremental innovation" could more easily highlight the relationship between "service innovation drive and service quality" as well as between "service innovation drive and customer satisfaction". Domenico, Francis, and Daniela (2014) explained service innovation as the innovation of service providers through service concepts or principles, the innovation of customer interface, the innovation of customer interface service delivery process and technology

selection, or the provision of better solutions for customers, as well as the enhancement of added value to exceed the expected experience and perception, and the constant promotion of innovation contents and value of services and products to increase customers' profits and satisfaction. Nanda, Kuruvilla, and Murty (2013) proposed that the role of service innovation was to ensure customer satisfaction and customer loyalty. Generally speaking, stores with higher customer satisfaction presented higher service innovation index, as the enhancement of income and consumption taste would receive customers' agreement and satisfaction (Gremyr et al., 2014). Solomon (2014) studied a famous five-star hotel in Taiwan and found out the significantly positive effect of service innovation on customer satisfaction, where new service innovation and new service effectiveness were the remarkable factors in the promotion of customer satisfaction. The following hypothesis is therefore proposed in this study.

**H1:** Service innovation shows significant correlations with customer satisfaction.

Yaşlıoğlu, Çalışkan, and Şap (2013) mentioned that the so-called service innovation should begin with customer needs; better expected products and services could be created merely when customers were understood and even the customers of customers were understood. Batnasan (2014) proposed that enterprises had to collect and analyze the data of demographic data and behaviors of consumers and potential customers through information technology to establish the customer database. Under long-term tracking, the database system could record the transaction information between enterprises and customers and enterprises could acquire customer needs through the database to improve the provided products or services so as to enhance the relationship between enterprises and customers. Grönroos and Voima (2013) indicated that service innovation should particularly stress on digging out the needs of targeted groups, as, without accurately grasping needs, the planning and design of following service process and service combination would deviate to result in service mistake and be hard to create customer value. Kang and Kang (2014) mentioned that there were beneficial tools for enterprises digging out customer needs, such as online click rate of products, data mining, membership keyword searching, and Factor Analysis. After finding out customer preference, enterprises could develop new service combination, aiming at customer needs, for the analysis with statistical tools and had to comprehend and grasp the meaning after the analysis. Employees' statistics education was therefore necessary to enhance the comprehension and analysis capabilities so as to accurately grasp the direction of service innovation. The following hypothesis is therefore established in this study.

**H2:** Statistics education reveals remarkable correlations with service innovation.

Zhang and Wu (2013) proposed that, to be active, enterprises had to regularly and irregularly survey customer satisfaction to understand the constantly changing customer needs and expectation and continuously improve products and product provision processes to be customer-centered. Heyne, Boettke, and Prychitko (2013) mentioned that customer satisfaction was used for measuring the degree of an enterprise or an industry satisfying or exceeding customer expectation of the purchased products. The customer satisfaction measuring process was the survey of customer satisfaction to find out key factors in customer satisfaction or dissatisfaction (it was sometimes called performance indicators when reflecting with statistical indicators). The statistical data were measured according to customers' opinions about such factors to further acquire the comprehensive customer satisfaction indicator. Tang (2013) indicated that the survey of customer satisfaction was essentially the process of quantitative analysis, i.e. reflecting customer attitudes towards the measured object with figures. In this case, it was necessary to precede quantitative analysis of the survey indicator. Yu et al. (2013) argued that an enterprise proceeding customer satisfaction survey was not simply for a comprehensive statistical indicator, but to find out key factors in customer satisfaction through statistical analyses in order to make effective customer satisfaction strategies in the process of enhancing customer satisfaction. Apparently, enterprises have to precede statistics education for employees comprehending and analyzing the survey result of customer satisfaction so as to definitely find out the direct key factors in customer satisfaction or dissatisfaction. Accordingly, the following hypothesis is proposed in this study.

**H3:** Statistics education presents notable correlations with customer satisfaction.

## EMPIRICAL RESEARCH DESIGN

### Research Object

Employees of Qianjiangyue Leisure Farm, as the research object, are distributed 330 copies of questionnaire. Total 278 valid copies are retrieved, with the retrieval rate 84%. Qianjiangyue Leisure Farm, a multi-functional agricultural park, with natural experience, tourism and recreation, and popular science education, is one of the earliest developed leisure farms as well as a mature recreational agricultural touring spot. The farm is equipped 5 ecological mountains and ponds, 2 streams, arable, forest, lawn, slope, reservoir, and streams. The stereoscopic climate in the farm is obvious with large temperature difference between day and night, outstanding biodiversity, and rich animal and plant species. There is a tourist service center in the farm, as well as areas of natural lawn, agricultural experience, popular science education, agricultural landscape, ecological barbecue, and green life. It

**Table 1.** Analysis of statistical education to service innovation

dependent variable →	service innovation					
	service concept		customer interface		service delivery	
	Beta	P	Beta	P	Beta	P
knowledge aspect	0.216**	0.005	0.231**	0.001	0.187*	0.013
affection aspect	0.211**	0.007	0.228**	0.003	0.243***	0.000
F	18.521		23.442		29.168	
significance	0.000***		0.000***		0.000***	
R2	0.173		0.212		0.269	
adjusted R2	0.156		0.178		0.245	

Note: \* stands for  $p < 0.05$ , \*\* for  $p < 0.01$ , \*\*\* for  $p < 0.001$ .

Data source: Self-organized in this study

presents the advantage of good resources when creating the agricultural production experience environment and constructing waterscape, geographic landscape, and biological landscape.

## Analysis Method

Regression Analysis is applied to understand the relationship among service innovation, statistics education, and customer satisfaction.

## ANALYSIS RESULT

### Reliability and Validity Analysis

The statistical education problems in this study are calculated with Likert 5-point scale. With Factor Analysis, two factors of “knowledge aspect” (eigenvalue=1.835,  $\alpha=0.80$ ) and “affection aspect” (eigenvalue=1.627,  $\alpha=0.82$ ) are extracted. The accumulative covariance explained achieves 74.663%.

The service innovation problems in this study are measured with Likert 5-point scale. Three factors of “service concept” (eigenvalue=2.577,  $\alpha=0.88$ ), “customer interface” (eigenvalue=2.218,  $\alpha=0.85$ ), and “service delivery” (eigenvalue=1.732,  $\alpha=0.81$ ) are extracted with Factor Analysis. The accumulative covariance explained reaches 78.236%.

The customer satisfaction problems are measured with Likert 5-point scale. With Factor Analysis, two factors of “staff evaluation” (eigenvalue=3.166,  $\alpha=0.89$ ) and “merchandise valuation” (eigenvalue=3.021,  $\alpha=0.90$ ) are extracted. The accumulative covariance explained achieves 82.743%.

### Correlation Analysis of Statistical Education and Service Innovation

Regression Analysis is applied in this study to test the hypotheses and the theoretical structure. The first regression tests the effect of statistical education on service concept. The results reveal positive effects of knowledge aspect and affection aspect on service concept (Beta=0.216,  $p=0.005$ ; Beta=0.211,  $p=0.007$ ). The second regression tests the effect of statistical education on customer interface. The results show positive and significant effects of knowledge aspect and affection aspect on customer interface (Beta=0.231,  $p=0.001$ ; Beta=0.228,  $p=0.003$ ). The third regression tests the effect of statistical education on service delivery. The results present positive and remarkable effects of knowledge aspect and affection aspect on service delivery (Beta=0.187,  $p=0.013$ ; Beta=0.243,  $p=0.000$ ) (Table 1). Accordingly, H2: statistical education shows notable correlations with service innovation is supported.

### Correlation Analysis of Service Innovation and Customer Satisfaction

Regression Analysis is utilized for testing the hypothesis and the theoretical structure. The first regression tests the effect of service innovation on staff evaluation, revealing positive effects of service concept, customer interface, and service delivery on staff evaluation (Beta=0.211,  $p=0.006$ ; Beta=0.203,  $p=0.008$ ; Beta=0.231,  $p=0.001$ ). The second regression tests the effect of service innovation on merchandise valuation showing positive and significant effects of service concept, customer interface, and service delivery on merchandise valuation (Beta=0.189,  $p=0.011$ ; Beta=0.214,  $p=0.004$ ; Beta=0.226,  $p=0.002$ ) (Table 2). H1: service innovation presents remarkable correlations with customer satisfaction is therefore supported.

**Table 2.** Analysis of service innovation and statistical education to customer satisfaction

dependent variable →	customer satisfaction			
independent variable ↓	staff evaluation		merchandise valuation	
service innovation	Beta	P	Beta	P
service concept	0.211**	0.006	0.189*	0.011
customer interface	0.203**	0.008	0.214**	0.004
service delivery	0.231**	0.001	0.226**	0.002
F	21.233		25.462	
significance	0.000***		0.000***	
R2	0.204		0.238	
adjusted R2	0.178		0.211	

Note: \* stands for p<0.05, \*\* for p<0.01, \*\*\* for p<0.001.  
Data source: Self-organized in this study

**Table 3.** Analysis of service innovation and statistical education to customer satisfaction

dependent variable →	customer satisfaction			
independent variable ↓	staff evaluation		merchandise valuation	
statistical education	Beta	P	Beta	P
knowledge aspect	0.227**	0.002	0.241***	0.000
affection aspect	0.237**	0.001	0.218**	0.003
F	32.155		35.289	
significance	0.000***		0.000***	
R2	0.312		0.338	
adjusted R2	0.280		0.306	

Note: \* stands for p<0.05, \*\* for p<0.01, \*\*\* for p<0.001.  
Data source: Self-organized in this study

### Correlation Analysis of Statistical Education and Customer Satisfaction

Regression Analysis is used in this study for testing the hypothesis and the theoretical structure. The first regression tests the effect of statistical education on staff evaluation, revealing positive effects of knowledge aspect and affection aspect on staff evaluation (Beta=0.227, p=0.002; Beta=0.237, p=0.001). The second regression tests the effect of statistical education on merchandise valuation, showing positive and notable effects of knowledge aspect and affection aspect on merchandise valuation (Beta=0.241, p=0.000; Beta=0.218, p=0.003) (Table 3). Apparently, H3: statistical education shows remarkable correlations with customer satisfaction is supported.

### CONCLUSION

Increasing domestic and international emphases on service innovation in past years and factors of globalization, changing lifestyles, and the transfer of industrial focus have indirectly created business opportunities for leisure farms. However, in order to attract more customers to surpass competitors, the cultivated service innovation capability must present the uniqueness and be able to match customer needs. From the research results, leisure farms mainly provide services for customers that it is the labor-intensive industry. In this case, service staff becomes the frontline object to contact customers. In addition to certain professional knowledge and skills, service staff' service attitudes are the core of customer service. Nevertheless, products and services offered by any industries require constant progress and follow the step and needs of the world. In addition to make efforts for customer needs and habits, leisure farms have to constantly and positively search for methods to provide customers value. "Continuously looking for methods to provide value" is the only way to satisfy customers and enhance profits. When leisure farms promote the products or services with service innovation, the "use difficulty" should be taken into account. No matter how good services or products are provided by leisure farms, it would be a pity when customers do not know how to use them. For this reason, an easy-operation interface allows customers easily enjoying the services or products provided by businesses and could change and attract new customers who are not appealed by traditional methods. Leisure farms therefore have to reinforce employees' statistics education in order to correctly dig out customer value and services or products, which customers really need, in the huge marketing survey data to enhance leisure farms' competitiveness.

### SUGGESTION

Aiming at above research results, the following suggestions are proposed in this study.

1. Leisure farms are suggested to stress on service staff's attitudes, rather than stopping investing resources in service staff's statistics education and professional training. Moreover, service staff's behaviors, service attitudes, and knowledge & skills should be well trained to effectively enhance the quality and have customers be better satisfied with the serviced offered. The sensitivity to statistical data should be reinforced in the statistics education so that leisure farms do not simply acquire the comprehensive statistical index, but discover key factors in customer satisfaction through statistical analyses in order to enhance customer satisfaction.
2. Products and services offered by leisure farms are easily imitated by others in the same industry, as it is transparent and cannot be regulated with patents. Leisure farms therefore have to attract customers with diverse equipment and services. In this case, the development of new products and services with "delicate package" becomes critical. Leisure farms are suggested to constantly come out with rich and delicate product and service packages, i.e. reinforcing product use, function, or aesthetic appearance, as well as provide various service combinations to enhance the width and depth of services and have customers appear satisfaction and loyalty to leisure farms.
3. To understand customer satisfaction with leisure farms, some businesses would request customers filling in satisfaction survey or directly inquire customers' satisfaction to acquire customers' true needs through statistical data. Businesses are suggested to contact customers with positive methods, such as inquiring customers' consumption orientation by phones, surveying satisfaction with questionnaire, or directly asking customer needs, to realize customer needs as well as to have customers understand the efforts made by the businesses. It would provide customers with different perception from the past.

### ACKNOWLEDGEMENTS

Funding project support by No: 612014020, "Beautiful Village", the building innovative experimental zone, Fujian high-level university construction projects.

### REFERENCES

- Armstrong, G., & Kotler, P. (2014). *Marketing: An introduction (GE)* (12th ed.) England: Pearson Education.
- Aziz, N. A., & Omar, N. A. (2013). Exploring the Effect of Internet Marketing Orientation, Learning Orientation and Market Orientation on Innovativeness and Performance: SEM (Exporters) Perspectives. *Journal of Business Economics and Management*, 14(S1), 257-278. <https://doi.org/10.3846/16111699.2011.645865>
- Batnasan, J. (2014). *Exploring relationships among service innovations, customer satisfaction and customer value in airport* (Masters Thesis). Asia University, Department of Business Administration, Taiwan.
- Cox, R. (2013). *Environmental Communication and the Public Sphere* (3rd ed.). California: Sage.
- Domenico, D., Francis, E., & Daniela, S. (2014). The Impact of Public R&D on Marketing and Supply Chains on Small Farms' Market Sensing Capability: Evidence from the Australian Seafood Industry. *International Food and Agribusiness Management Review*, 17(1), 37-82.
- Farias, S. A., Aguiar, E. C., & Melo, F. V. S. (2014). Store atmospherics and experiential marketing: A conceptual framework and research propositions for an extraordinary customer experience. *International Business Research*, 7(2), 87. <https://doi.org/10.5539/ibr.v7n2p87>
- Gomez, L. F., & Ballard, D. I. (2013). Communication for the Long Term: Information Allocation and Collective Reflexivity as Dynamic Capabilities. *Journal of Communication*, 50(2), 208-220. <https://doi.org/10.1177/0021943612474992>
- Gremyr, I., Witell, L., Lofberg, N., Edvardsson, B., & Fundin, A. (2014). Understanding New Service Development and Service Innovation through Innovation Modes. *Journal of Business and Industrial Marketing*, 29(2), 123-131. <https://doi.org/10.1108/JBIM-04-2012-0074>
- Grimaldi, M., Quinto, I., & Rippa, P. (2013). Enabling Open Innovation in Small and Medium Enterprises: A Dynamic Capabilities Approach. *Knowledge and Process Management*, 20(4), 199-210. <https://doi.org/10.1002/kpm.1423>
- Grönroos, C., & Voima, P. (2013). Critical service logic: Making sense of value creation and co-creation. *Journal of the Academy of Marketing Science*, 41(2), 133-150. <https://doi.org/10.1007/s11747-012-0308-3>
- Heyne, P., Boettke, P. J., & Prychitko, D. L. (2013). *The economic way of thinking* (13th ed.) New York: Prentice Hall.
- Ho, H. D., & Ganesan, S. (2013). Does Knowledge Base Compatibility Help or Hurt Knowledge Sharing Between Suppliers in Coepetition? The Role of Customer Participation. *Journal of Marketing*, 77(6), 91-107. <https://doi.org/10.1509/jm.11.0570>

- Jeong, E. H., Jang, S. C., Day, J., & Ha, S. (2014). The impact of eco-friendly practices on green image and customer attitudes: An investigation in a café setting. *International Journal of Hospitality Management*, 41, 10-20. <https://doi.org/10.1016/j.ijhm.2014.03.002>
- Josiam, B. M., & Henry, W. (2014). Entertainment: Utilitarian and hedonic motivations for patronizing fun experience restaurants. *Procedia-Social and Behavioral Sciences*, 144, 187-202. <https://doi.org/10.1016/j.sbspro.2014.07.287>
- Kang, K. H., & Kang, J. (2014). Do External Knowledge Sourcing Modes for Service Innovation? Empirical Evidence from South Korean Service Firms. *Journal of Product Innovation Management*, 13(1), 176-191. <https://doi.org/10.1111/jpim.12087>
- Kindström, D., Kowalkowski, C., & Sandberg, E. (2013). Enabling service innovation: a dynamic capabilities approach. *Journal of Business Research*, 66(8), 1063-1073. <https://doi.org/10.1016/j.jbusres.2012.03.003>
- Namkung, Y., & Jang, S. (2013). Effects of restaurant green practices on brand equity formation: Do green practices really matter? *International Journal of Hospitality Management*, 33, 85-95. <https://doi.org/10.1016/j.ijhm.2012.06.006>
- Nanda, N., Kuruvilla, S. J., & Murty, B. V. R. (2013). Role of Service Innovation in Customer Satisfaction and Customer Loyalty: A Study on Organized Retail in India. *International Journal of Business Insights & Transformation*, 6(2), 53-63.
- Rosell, D. T., Lakemond, N., & Wasti, S. N. (2014). Integrating Knowledge with Suppliers at the R&D-Manufacturing Interface. *Journal of Manufacturing Technology Management*, 25(2), 240-257. <https://doi.org/10.1108/JMTM-12-2013-0171>
- Salunke, S., Weerawardena, J., & McColl-Kennedy, J. R. (2013). Competing through service innovation: The role of bricolage and entrepreneurship in project-oriented firms. *Journal of Business Research*, 66(8), 1085-1097. <https://doi.org/10.1016/j.jbusres.2012.03.005>
- Solomon, M. R. (2014). *Consumer behavior: Buying, having, and being* (10th ed.). Courier/Kendallville: Pearson College Div.
- Stickdorn, M., & Schneider, J. (2013). *This is service design thinking: Basics, tools, cases*. New Jersey: Wiley.
- Tang, T.-W. (2013). Competing Through Customer Social Capital: The Proactive Personality of Bed and Breakfast Operators. *Asia Pacific Journal of Tourism Research*, 20(2), 1-19.
- Trigo, A. (2013). The nature of innovation in R & D- and Non-R & D-intensive service firms: Evidence from firm-level latent class analysis. *Industry and Innovation*, 20(1), 48-68. <https://doi.org/10.1080/13662716.2013.761380>
- Tsai, K. H., & Hsu, T. T. (2014). Cross-Functional Collaboration, Competitive Intensity, Knowledge Integration Mechanisms, and New Product Performance: A Mediated Moderation Model. *Industrial Marketing Management*, 43, 293-303. <https://doi.org/10.1016/j.indmarman.2013.08.012>
- Tseng S. M., & Lee, P. S. (2014). The Effect of Knowledge Management Capability and Dynamic Capability on Organizational Performance. *Journal of Enterprise Information Management*, 27(2), 158-179. <https://doi.org/10.1108/JEIM-05-2012-0025>
- Yan, X., Wang, J., & Chau, M. (2013). Customer revisit intention to restaurants: Evidence from online reviews. *Information Systems Frontiers*, 17(3), 1-13.
- Yaşlıoğlu, M., Çalışkan, B. Ö. Ö., & Şap, Ö. (2013). The Role of Innovation and Perceived Service Quality in Creating Customer Value: A Study on Employees of a Call Center Establishment. *Procedia-Social and Behavioral Sciences*, 99, 629-635. <https://doi.org/10.1016/j.sbspro.2013.10.533>
- Yu, Y., Dong, X. Y., Shen, K. N., Khalifa, M., & Hao, J. X. (2013). Strategies, Technologies, and Organizational Learning for Developing Organizational Innovativeness in Emerging Economies. *Journal of Business Research*, 66, 2507-2514. <https://doi.org/10.1016/j.jbusres.2013.05.042>
- Zhang, J., & Wu, W. P. (2013). Social Capital and New Product Development Outcome: The Mediating Sensing Capability in Chinese High-Tech Firms. *Journal of World Business*, 48, 539-548. <https://doi.org/10.1016/j.jwb.2012.09.009>

<http://www.ejmste.com>



# Integration of Project Activity to Enhance the Scientific Process Skill and Self-Efficacy in Zoology of Vertebrate Teaching and Learning

Diana Hernawati <sup>1,2\*</sup>, Mohamad Amin <sup>3\*</sup>, Mimien Irawati <sup>3</sup>, Sri Indriwati <sup>3</sup>, Muhammad Aziz <sup>4</sup>

<sup>1</sup> Postgraduate Doctoral Student of Biology Study Program, State University of Negeri Malang, INDONESIA

<sup>2</sup> Study Program of Biology Education, FKIP, Universitas Siliwangi, Tasikmalaya, INDONESIA

<sup>3</sup> Department of Biology, Faculty of Mathematics and Natural Sciences, State University of Negeri Malang, INDONESIA

<sup>4</sup> Institute of Innovative Research, Tokyo Institute of Technology, Tokyo, JAPAN

Received 18 November 2017 • Revised 15 March 2018 • Accepted 15 March 2018

## ABSTRACT

This study is a quantitative research conducted to analyze the integration of project activity to increase the scientific process skill and self-efficacy. While uncovering the effect of each indicator of every predictor, a descriptive qualitative analysis has been done. Respondents in this research were biology students in teacher. The sample of 30 respondents were taken by random sampling technique. Research instruments were in the form of scientific process skill test and self-efficacy inventory. The hypothesis was tested using Analysis of Variance (ANOVA). Integration of project activity has significant effect towards scientific skill process at 0.038 with F value of 4.524 and also have a significant effect for self efficacy at 0.018 with F value of 0.018. Based on results analysis, it is concluded that there was an effect of project activity integration in Zoology of Vertebrate teaching and learning on pre-service teachers' scientific process skill and self-efficacy, with significance level of 0.05.

**Keywords:** project activity integration, scientific process skill, self-efficacy, student-teachers

## INTRODUCTION

Teacher is one of main dynamic factor to clarify the educational quality. Teachers' roles in educational system are very important so that in each reformation, teachers should review and document every problem with their solving strategy (Campbell, Zhang, & Neilson, 2011). The new paradigm in educational reform is to call for student preparation through innovative pedagogical strategies (Flores, 2015). To prepare to be an innovative teacher in conveying his learning experiences that impact on the students, transformational candidates are required (Calik, 2013). More aspects are needed to develop the skills that students need. Thus, teachers that are able to assist students in understanding and exploring scientific phenomena, scientific discussions, cognitive structural constructions, skills development and problem-solving improvement are needed (Duran & Dokme, 2016).

Problem solving can also be conducted through empowerment of various skills; one of them is scientific process skill. Scientific process skill is an adaptation of skills that scientists improve to build knowledge, solve problems and make conclusions (Karsli & Ayas, 2014; Ozgelen, 2012). These skills can also be transferred in a multidisciplinary manner (Halim & Meerah, 2012). Scientific process skill is very important for students because it is in accordance with the demand of content standard (inquiry and giving learning experience directly through the usage and development of process skill and scientific attitude), the core activity of science (product, process, technology application, and attitude), and increase the meaningfulness of science learning. The most important dimension of the nature of science is the way of reaching information and the phases of the scientific method. Inquiry can be considered as a strategy to develop various skills and help students to gain new information

#### Contribution of this paper to the literature

- Integration of project activities in the learning process can train students' basic and integrated science process skills.
- Integration of project activities also familiarize students to think creatively and critically, be proactive to conduct exploration related to investigation, and strengthen their self-efficacy.
- The roles of the instructor as facilitator, advisors, and intermediaries provide a good contribution to obtain optimal results in accordance with the imagination, creativity and innovation of students.

(Aljaafreh, 2013; Opatye, 2012; Zhao & Wardeska, 2011). Inquiry can also assist students in developing the skills needed throughout their lives (Duran & Dokme, 2016).

Ozyurt (2015) argued that problem solving is one of the main skills that individuals need to keep and improve. In this case, one of the goals of modern education is to prepare individuals who can build their own knowledge. Individuals who have characteristics can find their own information, flexible, open minded, always take different approaches to events and make deductive and inductive conclusions, tend to succeed in problem solving (Kanbay, Aslan, Işık, & Kılıç, 2013).

This research discusses serial discoveries from professional developmental study using a project learning model. This model is considered to have certain value by many researchers when being implemented in combination. Project work helps to bridge technical theoretical education and real-world, so it enriches and supports theoretical with conceptual understanding. Project work emphasizes more on hands-on applications that make students more independent and creative (Osuala & Onwuagbke, 2014; Sababha, Alqudah, Abualbasal, & AlQaralleh, 2016).

Project based learning uses the principle of learning by doing, which is a learning process by doing a particular action. Grant (2012) emphasized that in this learning method, students become more autonomous in developing and presenting their learning results. Tiantong and Siksen (2013) explained that project based learning improves students' creativity and psychomotor skills more. This project-oriented learning was done in the course of Vertebrate Zoology. This course can accommodate the various knowledge of high level animals from low Chordata. If these materials are examined more deeply by using the right learning model, it is very potential to develop and improve the skills of science processes and students self-efficacy. Tantrarungroj and Suwannatthachote (2012), and Habok and Nagy (2016) stated that the success of the project in learning depends on the number of student activities and a good learning environment.

A number of arguments and research results that have been stated above show the importance of scientific skill among the students. However, scientific process skill will be more meaningful if the students' self-efficacy had been trained since the early stage, as suggested by Bilgin, Karakuyu, and Ay (2015) argue that self-efficacy is an important concept in Bandura's social learning theory. It is about what to do and how much they can do to solve the problems that may occur. Self-efficacy has been identified as a consistent predictor of experience mastery (Uitto, 2014).

Therefore, it is important that the full skill of the scientific process are also observed. Self-efficacy is considered very essential or the success in the classroom (Krause, Pietzner, Dori, & Eilks, 2017). Although, this factor cannot be regarded solely as predictor for the academic success. The diverse capabilities of students having different characters require better emphasis on each of the competencies of self-efficacy.

To the best of author's knowledge, there is almost no research related to the integration of project activity in Vertebrate course towards Biology pre-service teacher's scientific process skill and self-efficacy. This is what lies behind this research, with the hope that this research could uncover how strong is the effect of project-oriented learning towards Biology pre-service teachers' scientific process skill and self-efficacy. It is also strongly expected that this research can be an effort in increasing the educational quality, motivate and increase the self-efficacy, increase the mastery of skills, enrich the experience, and boost the new spirit of pre-service teacher.

The question proposed in this research are: (1) how project activities in learning can affect the science process skills of biology teacher candidates; and (2) how project activities can affect the self-efficacy of biology teacher candidates. The main purpose of this study is to describe the effectiveness of project activities in vertebrate zoology learning on science process skills and students self-efficacy.

## LITERATURE REVIEW

### Project Based Learning

Project based learning is a form of constructivism and collaborative learning with a student-centered learning process (Whatley, 2012). While (Chiang & Lee, 2016) defined project learning as a process, in which knowledge is constructed through the transformation of experience. This model is able to construct students' knowledge in the hope of finding important information in constructing their own knowledge. In addition students are able to observe and analyze problems so as to construct more meaningful knowledge.

Bilgin et al. (2015) and Hung, Hwang, and Huang (2012) stated that project learning is a research-based investigation strategy to find solutions in daily life problems. In this approach, students take responsibility for working independently and cooperating with others, improving investigative skills, solving their problems and obtaining final product outcomes. Habok and Nagy (2016) found that PjBL has the ability to develop and manage group dynamics, to assist them in building confidence, and to practice teamwork skills.

### Scientific Process Skill (SPS)

Scientific process skills are defined as necessary and needed tools in research, investigation and critical thinking and become lifelong learners (Akgün, Tokur, & Duruk, 2016; Farsakoglu, Sahin, & Karsli, 2012). In addition Ozgelen (2012) defined the skills of the scientific process as the ability to think to solve problems, evaluate and formulate results. They are just parts of the whole science skill set. While to do experiment, it is needed to involve all basic and integrated process skills. Therefore, the full skill of the scientific process is necessary to be given.

Karsli and Ayas (2014) explained that scientific process skills are essential in teaching how to achieve the goal of knowledge in science education. The science process skill is one of the thinking skills used by both scientists, teachers and students while investigating and exploring in the context of science activities. The science process skill consists of basic and integrated science process skills. Basic science process skills include observation, measurement, classification, conclusion, prediction and communication. While the integrated science process involves determining and controlling variables, formulating hypotheses, data collection and operational definitions (Chabalengula, Mumba, & Mbewe, 2012; Erkol & Ugulu, 2014; Ongowo & Indoshi, 2013).

### Self-Efficacy

Mauer, Neergaard, and Linstad (2017) and Peters (2013) defined self-efficacy as in Alfred Bandura's social theory, which refers to the nature of individual competence assessment of a person's beliefs needed to be able or unable to overcome obstacles and barriers through effort and perseverance. Can (2015) explains that humans can have high self-efficacy in a different situation. The diverse self-efficacy of the situation depends on the competencies demanded for each activity, the level of competition among humans. The magnitude of individual self-efficacy is also determined when dealing with failure, and physiological conditions, in particular the presence or absence of fatigue, anxiety, apathy or sadness.

Saad and Boujaoude, (2012), Smolleck and Morgan (2011) revealed that self-efficacy is a powerful paradigm that can increase confidence and operate on the basis of motivation. While social theory described four types of information sources which are the main principles for building self-efficacy trust is sourced from the student's self-experience, the experience of others, physical or psychological condition, and from the verbal persuasion of the lecturer (Mauer et al., 2017).

## RESEARCH METHOD

This research involves a quantitative research aiming to analyze the effect of the integration project activity in Zoology of Vertebrate course of Biology for pre-service teachers' in scientific process skill and self-efficacy. While uncovering the effect of each indicator of every predictors, a descriptive qualitative analysis was done. Indicators of science process skills include observing, inferring, measuring, communicating, classifying, predicting, controlling variables, defining operationally, formulating hypothesis, interpreting data. While self-efficacy includes magnitude, strength and generality.

This study was conducted for 4 months from February to May 2017. There were nine material topics that students studied during this study, namely hemichordata, urochordata, sefalochordata, agnatha, pisces, amphibia, reptiles, aves and mammals. The experimental class and the conventional class all studied the nine topics. Project activities are independent variables, while science process skills and self-efficacy are the dependent variables. Class meetings are held once a week and each lesson lasts 150 minutes.

The implementation of project activities in the experimental class is carried out gradually in accordance with the project learning steps referring to Sumarni, Wardani, Sudarmin, and Gupitasari (2016), Grant (2012) includes stage (1) student orientation on project issues; (2) organization of teaching and learning activities; (3) project guidance; (4) development and presentation of project results; and (5) analysis and evaluation of learning process and project result reflection. As for the conventional class during the last five years apply conventional lab work. The application of a conventional practicum is based on a complete experimental instruction containing objectives, basic theories, tools and materials, work procedures and presentation data tables.

Respondents in this study are future biology teachers who attended Vertebrate Zoology in 6th semester academic year 2016/2017 at Siliwangi University Tasikmalaya Indonesia consisting of 210 students. A sample of 30 students taken with cluster random sampling technique. The design used was quasi-experimental, posttest only design group control (Creswell, 2012).

The research instrument is a test of science process skill and inventory for self-efficacy. The science-process skills test consists of 20 items that have been validated by a science expert and tested against a student who is not a research sample. The test is given in the form of an essay test as indicated by Erkol and Ugulu (2014), Ongowo and Indoshi (2013), and Chabalengula et al. (2012) as mentioned above. The questions consist of two questions for each skill. For example, the question of observing and classifying skills refers to the scenario of specimen morphology observed. From the observation will get any characteristics that can be used as the basis of taxon level grouping. As an example, a sample problem is presented.

- Based observation result by video on the slide show and some original specimens from the Pisces class, it is known that the Pisces class has a moving ability that is influenced by several factors.

**Question:** If you are given the opportunity to research the Pisces population whose distribution is large enough, what do you do to distinguish between Chondrichthyes and Osteichthyes class?

- Observe as the frog jumps, the frog's longer legs are longer and stronger than the front legs. While his body is short.

**Question:** Can you explain why?

The self-efficacy inventory was adapted from the general self-efficacy (GSE) by Luszczynska, Gutiérrez-Doña, and Schwarzer (2005), which was then adapted to the indicators to be measured in the study. These indicators refer to Bandura (1997) about self-efficacy. The inventory consists of 30 statement items with alternate subject responses on a scale of 11 with 1 - 100 intervals starting from 0 - 49 (not sure of being able to do), 50-89 (pretty sure capable of doing), and 90-100 (very confident of being able to do) at intervals of 10. To explain the effect size, d-Cohen effect size is used (Gravetter & Wallnau, 2004). For example, questions are presented to the respondent to choose an alternative answer by circling the numbers corresponding to the perceived experience.

- When given a critical analytical task by a lecturer, I am sure I can do it well.

0 10 20 30 40 50 60 70 80 90 100

- I can communicate it back to my friends based on my learning experience

0 10 20 30 40 50 60 70 80 90 100

- When I am going to do a presentation regarding to group project results, I am more confident about doing it myself

0 10 20 30 40 50 60 70 80 90 100

Validity and reliability test were determined based on the results of the trials on 32 biology teacher candidates who were not research samples. Reliability test results with Crocbachs Alpha showed a result of 0.847 for science process skills and 0.914 for self-efficacy. Problems of science process and self-efficacy have been tested for validity using Pearson Correlation test which shows all items valid.

The research data were tested statistically by using ANOVA which aims to explain the difference between more than two groups of samples with significance level of 5% ( $p < 0.5$ ) (Mertler, & Reinhart, 2016). The data obtained were first tested on the prerequisite of the analysis including the Kolmogorov-Smirnov normality test and homogeneity of variance using Levenes-Test. The hypothesis tested is that there is no effect of project activity integration to improve the science process and self-efficacy skills. All data testing is done by using Program SPSS version 23.0 for windows.

## RESULTS AND DISCUSSION

### Project Activity Implementation

Descriptive data analysis on the integration of project activities in the learning process is presented in [Table 1](#).

**Table 1.** Results of Analysis of Project Activity Integration Activities

Project Syntax	Activity (value in %)						
	1	2	3	4	5	6	7
Student orientation on the problem	66.67	77.78	88.89	77.78	77.78	77.78	88.89
Organize students to learn	88.89	66.67	77.78	77.78	77.78	88.89	88.89
Guide students to carry out project activities	83.33	83.33	83.33	83.33	83.33	66.67	66.67
Develop and present the project results	66.67	66.67	83.33	83.33	66.67	83.33	83.33
Analyze and evaluate the process activities	66.67	66.67	66.67	83.33	83.33	83.33	83.33
Average	74.45	75.56	80	77.78	80	80	82.22

**Table 2.** Analysis summary of project activity integration on biology prospective teacher's scientific process skill

	Sum of Squares	Df	Mean Square	F	Sig.
Between groups	35.267	1	35.267	4.524	0.038
Within groups	452.133	58	7.795		
Total	487.400	59			

The learning process by integrating the project activities gives good results when it is seen from **Table 1** data presentation. Projects conducted by students in some activities still require direction and guidance during the learning process. Students are still less critical in investigating and analyzing the data required to complete the project, therefore, it should be emphasized repeatedly. In addition, with various activities and repeated emphasis it can improve the students' skill. Students can also work cooperatively and collaboratively with their groups so that the projects created during some activities can produce the expected products. To achieve a habituation in exploring through learning investigation, problem organizing, data organization, hypothesis making, and reflection during project activities need to be improved.

### Integration of Project Activities to the Process Skills of Science

The data analysis was carried out to explain the effect of project activity integration in Vertebrate course of Biology pre-service teachers' scientific process skill. The result are presented in **Table 2**.

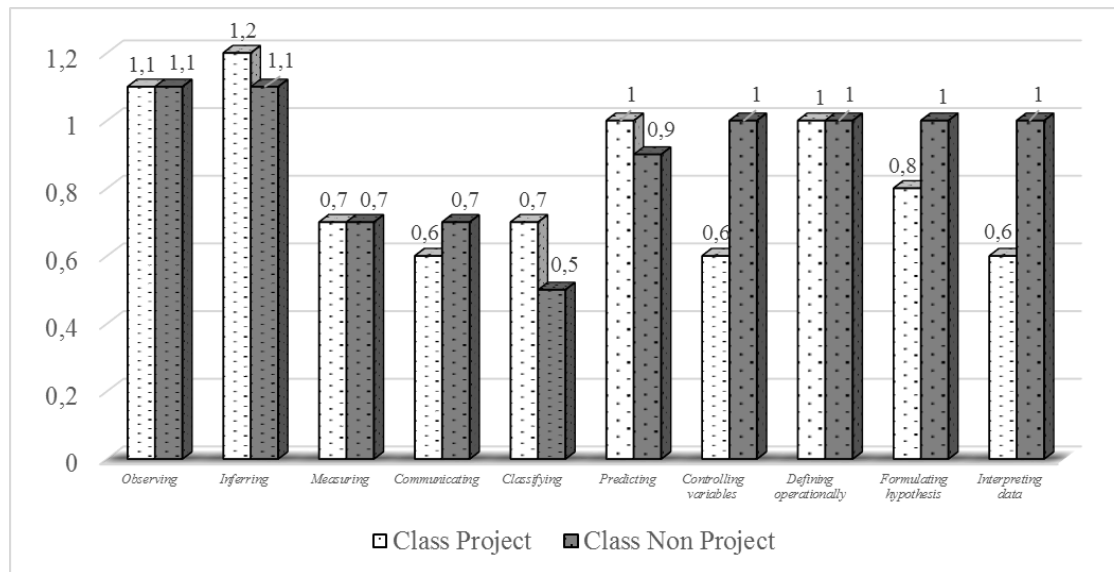
The result of ANOVA test shows that the effect of the integration of project activity to the pre-service teachers' scientific process skill in Vertebrate course was very significant. It can be seen from the calculation result (0.038) with the F value of 4.524.

This result is in accordance with a number of previous researchers that have studied the relationship between project-based learning as a learning model or strategy and scientific process skill as well as self-efficacy. Project-based learning serves a feasible way to combine learning activities in the classroom. A study of literature showed that project-based learning can promote the development of higher cognitive level and offer various forms of performance assessment (Grant, 2012; See & Rashid, 2015). Other result showed that students who have difficulties in conventional learning obtained significant benefits through project-based learning experience (Cooper & Kotys-Schwartz, 2010). Thus, project-based learning can develop better performance skills (Demir, 2013). More importantly when students do project work, their abilities increase due to experience in performing complex skills (Kibirige & Hodi, 2013; Lee, Lai, Yu, & Lin, 2012; Owolabi & Oginni, 2012). This finding is becoming even more important for the students who study through project-based learning. Therefore, this learning strategy can be an alternative to place them as a student in better position (Tiantong & Siksen, 2013).

Based on the study conducted by See and Rashid (2015) it was explained that project-based learning showed positive results with the creation of active learning that was interesting and meaningful. Opatye (2012) explains that the mastery of science process skills allows students to conceptualize at a deeper level. In addition, he also classified this scientific process skill into the skill of information processing, reasoning, inquiry, and creative thinking skills. Lattimer and Riordan (2011) and Bédard, Lison, Dalle, Côté, and Boutin (2012) stated that project-based learning is a learning where the students respond to the questions around the real world or solve a problem through inquiry process, develop their thinking skill, creativity, and encourage them to cooperate in a team. Chiang and Lee (2016) explained that project-based learning can also create an environment that helps the students to build a meaningful knowledge and become active in student-centered learning, and encourages them to collaborate and solve the problems on relevant knowledge and skill.

Generally, Hung et al. (2012) revealed that project-based learning can improve students' motivation in learning science, ability to solve problems and improve learning achievement. Recent study of Mayer (2013) showed that well-designed project process can help the students to reach better knowledge and skills than lectures in engineering education. Other findings in laboratory work project work can help students visualize abstract concepts into real, develop student performance directions and easily understood by students (Pekbay & Kaptan,





**Figure 1.** Average score of scientific process skill in project class and non-project class

2014; Tafa, 2012). These findings confirmed that scientific process skill can be trained and developed through integration of project in learning process, project-based learning, or combination of project-based learning with other learning strategies.

Further explanation related to each indicator's position on scientific process skill is shown in **Figure 1**. Based on the research result, the project class and non-project class have the same ability on observing, measuring, and making operational definition. Observation is the most basic process in science (Duran, Işık, Mihalidiz, & Özdemir, 2011; Feyzioglu, Demirdag, Akyildiz, & Altun, 2012). Measurement is a quantitative representation of observation, which can be conducted by making operational definition of variables, that will vary according to the facts, phenomena, and related variables which cannot be measured directly. This measurement can be done using standard and non-standard sizes to illustrate each dimension (Ongowo & Indoshi, 2013).

The ability of making conclusion, classifying, and predicting of project class is higher than those of non-project class. The ability of making conclusion refers to the development of observation and previous knowledge, leading to the ability of classifying. Someone can categorize an object surely based on the similarity, difference, and relations between objects. Therefore, classification has an exclusive role in developing various conceptions. This is because facts and generalization must be gathered and arranged to form a concept. Predicting is an important part of science, which refers to how someone make a specific statement about what will happen. An accurate prediction needs thorough observation and correct measurement Prediction also states the stating of the outcome of a future event based on a pattern of evidence (Chabalengula et al., 2012; Ongowo & Indoshi, 2013).

The result also showed that students of non-project class have higher ability to communicate, control variable, make hypotheses, and interpret data than the students of project class. Communication is important as human's fundamental effort in making argument. Communication can be done through using words or symbols to describe an action, object or event. Variable controlling is also an important skill to increase the data validity and reliability as well as managing a scientific investigation (Chabalengula et al., 2012; Ongowo & Indoshi, 2013). Making a hypothesis or statement about the possibility of variable's relationship is another fundamental skill which is based on observation. Data interpretation is related to data analysis which are organizing, concluding from data and making sense of data. Hence, people can easily find a pattern that leads to the conclusion or hypothesis (Erkol & Ungulu, 2014; Ongowo & Indoshi, 2013).

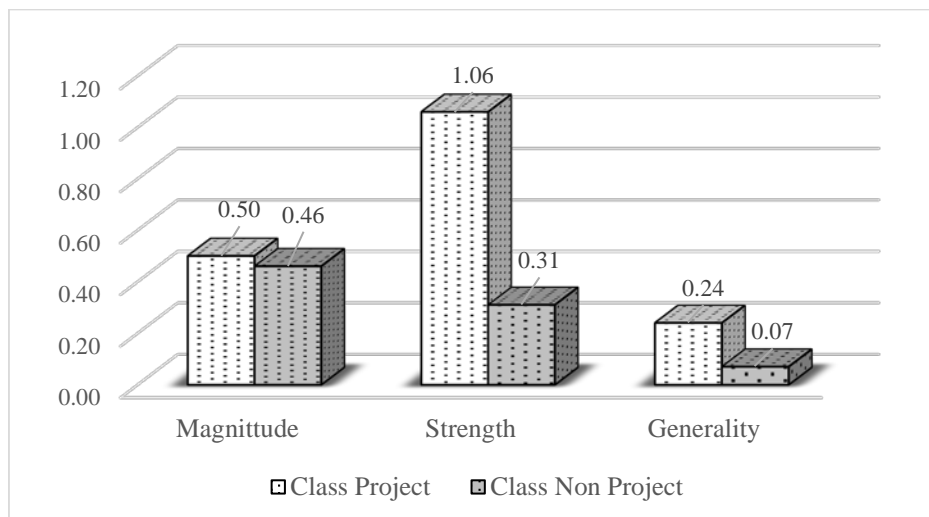
When it is examined from the point of view of behavioral theory, Schunk, Meece, and Pintrich (2012) stated that learning behavior can affect the learning process. Some things suggested in behavioral learning theory including emphasize on stimulus presentation and response reinforcement (Thorndike's learning theory), habituation (Pavlov's theory), and reinforcement (Skinner's theory) were not yet attached to some indicators in project class. Students' ability in exploring themselves are still less so that meaningful learning concept as in Ausubel's theory needs to be emphasized as a challenge and have a positive opportunity to be better.

A number of research findings supported that the scientific process skill is related strongly to the cognitive development, supports the students' thinking, reasoning, investigating, evaluating, problem solving skill, and creativity (Özgelen, 2012). Moreover, there is a strong relationship between students' achievement and learning



**Table 3.** Analysis summary of project integration on biology teacher on student's self-efficacy

	Sum of Squares	Df	Mean Square	F	Sig.
Between Groups	380.017	1	380.017	5.952	0.018
Within Groups	3703.233	58	63.849		
Total	4083.250	59			

**Figure 2.** Average score of self-efficacy in project and non-project classes

process skill. Previous study suggested that scientific process skill is another important factor that is necessary for problem solving and live functionality (Jack, 2013).

The researchers believe that a positive attitude toward science makes students more interested in focusing on the process of science. In other words when students understand the skills of the science process, it becomes more interesting to them, so as to enhance a positive attitude toward science (Zeidan & Jayosi, 2015). Al-rabaani (2014) investigated the acquisition of science process skill by teachers. The results showed that they had a moderate acquisition of science skills and showed no differences in outcomes by sex).

### Integration of Project Activities to the Self-Efficacy

The analysis of the project activities on the self-efficacy of Biology student teacher is shown in [Table 3](#).

The analysis results related to the effect of project on biology prospective teacher's self-efficacy is shown in [Table 3](#). There is a significant effect of project integration on biology teacher on student's self-efficacy, which is indicated by calculation result significance as much as 0.018 with the F value of 5.952.

Project-based learning is also affecting biology pre-service teachers' self-efficacy based on the result of data analysis. English and Kitsantas (2013) explained that in order to succeed in a project, students must be responsible to their own learning process, including the process of self-regulation to maintain motivation, specify the goals, and progress on self-reflection. A number of research findings revealed that significant learning results in engineering design have direct relationship with project experience and show the development of self-efficacy (Chen, Hernandez, & Dong, 2015). The process of project experience can help students improve their self-efficacy and sustainable learning process (Al-Amous, et al., 2011; Demir, 2013). Various research findings that had been explained confirm that self-efficacy can be trained and developed through habituation of project-based learning process.

[Figure 2](#) shows the effect of each indicator on self-efficacy. The existence of self-efficacy in learning process with different level which is charged to individual produce a challenge with different level as well. The magnitude level for project class of 0.50 can be explained that the effect of project work on self-efficacy is in the medium category. So is the case for the non-project class of 0.46 with the explanation that the magnitude of influence is in the medium category. For higher project grade strength level with d-value of 1.06, it can be explained that the project work has a significant effect on self-efficacy and non-project grade with a d-value of 0.31 medium effect on self-efficacy. Generality level of project class is higher with d-value of 0.24 with moderate effect conclusions for project work on self-efficacy and non-project grade of 0.07 with the conclusion of project work has little effect on self-efficacy.

Can (2015) described that understanding the source of self-efficacy is expected to shape the right behavior and value of results. Therefore, more direct activities, research projects, laboratory experiments, and an active learning

environment will be influential in assisting candidate of biology teachers to find solutions in teaching problems. Therefore, Bilgin et al. (2015) explains that self-efficacy is an important target for individuals to be able to make their own decisions about how much effort they need to make in achieving their personal goals.

Studies by Ekici, Fettahloğlu, and Çıbık (2012) showed that experience can increase self-efficacy. Experience also maintains the effectiveness of individual self-efficacy (Flores, 2015). The success of an individual in facing a life problem can build a positive feeling; even more when self-efficacy has not been strongly established in individual. Another finding showed that self-efficacy is a reliable predictor for prominent results such as motivation and academic achievement (Richardson, Abraham, & Bond, 2012).

Magnitude aspect represents one's ability to accomplish a task with different level of difficulties. Individual with high level of self-efficacy will have high confidence about his/her ability to do a particular work or task. Otherwise, individual with low level of self-efficacy will have low confidence about his/her ability to do the task. Self-efficacy can be shown in different level charged to individual, in which there will be challenges in different levels for each individual to reach the success. In this research, students of project class as well as non-project class were provided with the same level of difficulties of given task. It can be reflected to each student's self-efficacy, as written by Flores (2015), that self-efficacy effectively affects student achievement.

Strength is the stability of confidence referring to the degree of individual's stability on their confidence or hope. Ones have strong confidence and perseverance in their efforts, although there are difficulties and hindrances. By empowering self-efficacy, the power of bigger effort can be achieved. The stronger self-efficacy and perseverance the students have, the higher possibility of success they get. In accordance with this research, students of project class received higher challenge in the accomplishment of their project. It is in line with Louis and Mistele (2012) explanation that self-efficacy affects one's choice and the amount of effort that will be done.

Generality is the discretion of one's self efficacy to be used in other different situations. Individual with high self-efficacy will be more adaptive to situations. The ability of individuals to work on particular field and context reveals the general description of their self-efficacy. In this research, students tend to be less revealing about their experience during the accomplishment of the project, so that it affected the generality. The existence of progress report in project-based learning became a new environment that caused a little awkwardness among the students. Therefore, habituation in project-based learning process is really necessary. This statement is supported by Uitto (2014) that self-efficacy is positively correlated with academic ability. Research results showed that self-efficacy can be taken into consideration in determining how well the learning result that can be achieved by individuals.

## CONCLUSIONS

Based on the above discussion, it is concluded that the integration of the project activity has a significant effect towards the scientific skill process at 0.038 with F value of 4.524 and also has a significant effect for self-effectiveness at 0.018 with F value of 0.018. Based on the results analysis, integration of Zoology of Vertebrate teaching and learning process on pre-service teachers' can improve the scientific process skill and self-efficacy, with significance level of 0.05.

The integration of project activities in the learning process tends to have a higher potential in improving the skills of science process skills and self-efficacy of biology teacher candidates. Statistical analysis shows that project activities significantly influence the skills of the science process and self-efficacy of biology teacher candidates. It is believed that the integration of project activities has the proper learning stages required by students in improving their achievements. Students engage in various skills and foster their self-efficacy.

This study contributes to the biology teacher candidates and lecturers to apply project integration projects involving multiple skills in training and developing science process skills and self-efficacy. Another thing of self-efficacy provides reinforcement during the learning process. The implications of this study include that the higher education curriculum should pay more attention to small research activities, especially those that directly impact on improving learning and improving the performance of biology teacher candidates in science learning.

Limitations of this research are the number of samples less representative in representing research. Another thing is the limited concept of discussion in research on low chordata material in the absence of original specimens as samples during the learning process. For further research it is suggested to add number of samples to represent the respondent representation and to expand the study material study.

## REFERENCES

- Akgün, A., Tokur, F., & Duruk, U. (2016). Associating conceptions in science teaching with daily Water chemistry and water treatment. *Adiyaman University Journal of Educational Science*, 6(1), 161-178.

- Al-Amoush, A.S., Markic, S., Abu-Hola, I. & Eilks, I. (2011). Jordanian prospective and experienced chemistry teachers' beliefs about teaching, learning and their potential role for educational reform, *Science Education International*, 22(3), 185-201.
- Aljaafreh, I. J. A. R. (2013). The effect of using the directed inquiry strategy on the development of critical thinking skills and achievement in physics of the tenth-grade students in Southern Mazar. *Journal of Education and Practice*, 4(27), 191-197.
- Al-rabaani, A. (2014). The acquisition of science process skills by Omani's pre-service social studies' teachers. *European Journal of Educational Studies*, 6(1), 13-19.
- Bandura, A. (1997). *Self-efficacy: The exercise of control*. New York: W.H Freeman and Company.
- Bédard, D., Lison, C., Dalle, D., Côté, D., & Boutin, N. (2012). Problem-based and Project-based Learning in Engineering and Medicine: Determinants of Students' Engagement and Persistence. *Interdisciplinary Journal of Problem-Based Learning*, 6(2). <http://dx.doi.org/10.7771/1541-5015.1355>
- Bilgin, I., Karakuyu, Y., & Ay, Y. (2015). The effects of project based learning on undergraduate students' achievement and self-efficacy beliefs towards science teaching. *Eurasia Journal of Mathematics, Science & Technology Education*, 11(3), 469-477. <https://doi.org/10.12973/eurasia.2014.1015a>
- Calik, M. (2013). Effect of technology-embedded scientific inquiry on senior science student teachers' self-efficacy. *Eurasia Journal of Mathematics, Science & Technology Education*, 9(3), 223-232. <https://doi.org/10.12973/eurasia.2013.931a>
- Campbell, T., Zhang, D., & Neilson, D. (2011). Model based inquiry in the high school physics classroom: an exploratory study of implementation and outcomes. *Journal of Science Education and Technology*, 20(3), 258-269. <https://doi.org/10.1007/s10956-010-9251-6>.
- Can, H. (2015). Sources of Teaching Efficacy Beliefs in Preservice Science Teachers. *İlköğretim Online*, 14(3). <https://doi.org/10.17051/io.2015.44466>.
- Chabalengula, V. M., Mumba, F., & Mbewe, S. (2012). How pre-service teachers' understand and perform science process skills. *Eurasia Journal of Mathematics, Science & Technology Education*, 8(3), 167-176. <https://doi.org/10.12973/eurasia.2012.832a>.
- Chen, P., Hernandez, A., & Dong, J. (2015). Impact of collaborative project-based learning on self-efficacy of urban minority students in engineering. *Journal of Urban Learning, Teaching, and Research*, 11, 26-39.
- Chiang, C. L., & Lee, H. (2016). The effect of project-based learning on learning motivation and problem-solving ability of vocational high school students. *International Journal of Information and Education Technology*, 6(9), 709-712. <https://doi.org/10.7763/ijiet.2016.v6.779>
- Cooper, L. A., & Kotys-Schwartz, D. A. (2013). *Designing the Design Experience – Identifying Factors of Student Motivation in Project-Based Learning and Project-Based ServiceLearning*. The ASEE Annual Conference & Exposition, Atlanta, GA.
- Creswell, J. W. (2012). *Educational research: planning, conducting, and evaluating quantitative and qualitative research*. Boston: Pearson
- Demir, T. (2013). Project-based learning approach in Turkish teaching lessons, *Journal of Mother Tongue Education*, 1(1), 53-76.
- Duran, M., & Dökme, İ. (2016). The effect of the inquiry-based learning approach on student's critical-thinking skills. *Eurasia Journal of Mathematics, Science & Technology Education*, 12(12). <https://doi.org/10.12973/eurasia.2016.02311a>
- Duran, M., Işık, H., Mıhladiz, G., & Özdemir, O. (2011). The Relationship between the Pre-Service Science Teachers' scientific Process Skills and Learning Styles. *Western Anatolia Journal of Educational Sciences (WAJES), Dokuz Eylül University Institute, Izmir, Turkey*.
- Ekici, G., Fettahloğlu, P., & Çıbık, A. S. (2012). Biology self-efficacy beliefs of the students studying in the department of biology and department of biology teaching. *International Online Journal of Educational Sciences*, 4(1)
- English, M. C., & Kitsantas, A. (2013). Supporting student self-regulated learning in problem-and project-based learning. *Interdisciplinary journal of problem-based learning*, 7(2), 6. <https://doi.org/10.7771/1541-5015.1339>.
- Erkol, S., & Ugulu, I. (2014). Examining Biology Teachers Candidates' Scientific Process Skill Levels and Comparing These Levels In Terms Of Various Variables. *Procedia-Social and Behavioral Sciences*, 116, 4742-4747. <https://doi.org/10.1016/j.sbspro.2014.01.1019>
- Farsakoglu, O. F., Sahin, C., & Karsli, F. (2012). Comparing science process skills of prospective science teachers: A cross-sectional study. *Asia-Pacific Forum on Science Learning and Teaching*, 13(1).

- Feyzioglu, B., Demirdag, B., Akyildiz, M., & Altun, E. (2012). Developing a Science Process Skills Test for Secondary Students: Validity and Reliability Study. *Educational Sciences: Theory and Practice*, 12(3), 1899-1906.
- Flores, I. M. (2015). Developing preservice teachers' self-efficacy through field-based science teaching practice with elementary students. *Research in Higher Education Journal*, 27, 1.
- Grant, M. M. (2012). Getting a grip on project-based learning: theory, cases and recommendations. *Meridian*, 5(1), 1-3.
- Gravetter, F. J., & Wallnau, L. B. (2004). *Statistics for the behavioral sciences*. Sixth edition. Belmont, CA: Wadsworth/Thomson.
- Habok, A., & Nagy, J. (2016). In-service teachers' perceptions of project-based learning *SpringerPlus*. <https://doi.org/10.1186/s40064-016-1725-4>
- Halim, L. E., & Meerah, T. S. (2012). Perception, conceptual knowledge and competency level of integrated science process skill towards planning a professional enhancement programme. *Sains Malaysiana*, 41, 921-930.
- Hung, C. M., Hwang, G. J., & Huang, I. (2012). A Project based Digital Storytelling Approach for Improving Students' Learning Motivation, Problem-Solving Competence and Learning Achievement. *Educational Technology & Society*, 15 (4), 368-379.
- Jack, G. U. (2013). The influence of identified student and school variables on students' science process skills acquisition. *Journal of Education and Practice*, 4(5), 16-22.
- Kanbay, Y., Aslan, Ö., Işık, E., & Kılıç, N. (2013). Problem solving and critical thinking skills of undergraduate nursing students. *Journal of Higher Education and Science*, 3(3), 244-251
- Karsli, F., & Ayas, A. (2014). Developing a laboratory activity by using 5E learning model on student learning of factors affecting the reaction rate and improving scientific process skills. *Procedia-Social and Behavioral Sciences*, 143, 663-668. <https://doi.org/10.1016/j.sbspro.2014.07.460>
- Kibirige, I., & Hodi, T. (2013). Learners' performance in physical sciences using laboratory investigation.. *International Journal of Education Science*, 5(4), 425-432. <https://doi.org/10.1080/09751122.2013.11890104>
- Krause, M., Pietzner, V., Dori, Y. J., & Eilks, I. (2017). Differences and Developments in Attitudes and Self-Efficacy of Prospective Chemistry Teachers Concerning the Use of ICT in Education. *Eurasia Journal of Mathematics, Science and Technology Education*, 13(8), 4405-4417. <https://doi.org/10.12973/eurasia.2017.00935a>
- Lattimer, H., & Riordan, R. (2011). Project-based learning engages students in meaningful work: Students at High Tech Middle engage in project-based learning. *Middle School Journal*, 43(2), 18-23. <https://doi.org/10.1080/00940771.2011.11461797>
- Lee, S. W.-Y., Lai, Y.-C., Yu, H.-T. A., & Lin, Y.-T. K., (2012). Impact of biology laboratory courses on students' science performance and views about laboratory courses in general: Innovative measurements and analyses. *Journal of Biological Education*, 46(3), 173-179. <https://doi.org/10.1080/00219266.2011.634017>
- Louis, R. A., & Mistele, J. M. (2012). Differences in scores and self-efficacy by student gender in mathematics and science. *International Journal of Science and Mathematics Education*, 10(5), 1163-1190. <https://doi.org/10.1007/s10763-011-9325-9>
- Luszczynska, A., Gutiérrez-Doña, B., & Schwarzer, R. (2005). General self-efficacy in various domains of human functioning: Evidence from five countries. *International journal of Psychology*, 40(2), 80-89. <https://doi.org/10.1080/00207590444000041>.
- Mayer, R. (2013). *How engineers learn: a study of problem-based learning in the engineering classroom and implications for course design* (Graduate Theses and Dissertations). Paper 13202, Iowa State University.
- Mauer, R., Neergaard, H., & Linstad, A. K. (2017). Self-efficacy: Conditioning the entrepreneurial mindset. In *Revisiting the Entrepreneurial Mind* (pp. 293-317). Springer, Cham. [https://doi.org/10.1007/978-1-4419-0443-0\\_11](https://doi.org/10.1007/978-1-4419-0443-0_11)
- Mertler, C. A., & Reinhart, R. V. (2016). *Advanced and multivariate statistical methods: Practical application and interpretation*. Taylor & Francis.
- Ongowo, R. O., & Indoshi, F. C. (2013). Science process skills in the Kenya certificate of secondary education biology practical examinations. *Creative Education*, 4(11), 713. <https://doi.org/10.4236/ce.2013.411101>
- Osuala, R. C., & Onwuagboke, B. B. C., (2014). The Place of information and communication in students' cognitive assessment in imo state tertiary institutions. *International Journal of Education and Research*, 2(11), 177-188.

- Opateye, J. A. (2012). Developing and assessing science and technology process skills in Nigerian universal basic education environment. *Journal of Education and Society Research*, 2, 34-42.
- Owolabi, T. & Oginni, I., (2012). Improvisation of science equipment in Nigerian schools. *Universal Journal of Education and General Studies*, 1(3), 44-48.
- Özgelen, S. (2012). Students' science process skills within a cognitive domain framework. *Eurasia Journal of Mathematics, Science & Technology Education*, 8(4), 283-292. <https://doi.org/10.12973/eurasia.2012.846a>.
- Özyurt, Ö. (2015). Examining the Critical Thinking Dispositions and the Problem Solving Skills of Computer Engineering Students. *Eurasia Journal of Mathematics, Science & Technology Education*, 11(2). <https://doi.org/10.12973/eurasia.2015.1342a>
- Pekbay, C., & Kaptan, F., (2014). Improvement of preservice science teachers' awareness on the effectiveness of laboratory method in science education: A qualitative study. *Karaelmas Journal of Educational Sciences*, 2, 1-11.
- Peters, M. L. (2013). Examining the relationships among classroom climate, self-efficacy, and achievement in undergraduate mathematics: A multi-level analysis. *International Journal of Science and Mathematics Education*, 11(2), 459-480. <https://doi.org/10.1007/s10763-012-9347-y>
- Richardson, M., Abraham, C., & Bond, R. (2012). Psychological correlates of university students' academic performance: a systematic review and meta-analysis. *Psychological bulletin*, 138(2), 353. <https://doi.org/10.1037/a0026838>.
- Saad, R., & BouJaoude, S., (2012). The relationship between teachers' knowledge and beliefs about science and inquiry and their classroom practices. *Eurasia Journal of Mathematics, Science & Technology Education*, 8(2), 113-128. <https://doi.org/10.12973/eurasia.2012.825a>
- Sababha, B. H., Alqudah, Y. A., Abualbasal, A., & AlQaralleh, E. A. (2016). Project-based learning to enhance teaching embedded systems. *Eurasia Journal of Mathematics, Science & Technology Education*, 12(9), 2575-2585. <https://doi.org/10.12973/eurasia.2016.1267a>
- See, Y. G., & Rashid, A. M. (2015). The effect of project based learning on level of content knowledge of pre-vocational subject. *Mediterranean Journal of Social Sciences*, 6(6 S4), 369. <https://doi.org/10.5901/mjss.2015.v6n6s4p369>.
- Smolleck, L. A., & Mongan, A. M. (2011). Changes in preservice teachers' self-efficacy: From science methods to student teaching. *Journal of Educational and Developmental Psychology*, 1(1), 133-145. <https://doi.org/10.5539/jedp.v1n1p133>.
- Schunk, D. H., Meece, J. R., & Pintrich, P. R. (2012). *Motivation in education: Theory, research, and applications*. Pearson Higher Ed.
- Sumarni, W., Wardani, S., Sudarmin, S., & Gupitasari, D. N. (2016). Project based learning (pbl) to improve psychomotoric skills: a classroom action research. *Jurnal Pendidikan IPA Indonesia*, 5(2), 157-163.
- Tafa, B., (2012). Laboratory activities and students practical performance: The case of practical organic chemistry I course of Haramaya University. *AJCE*, 2(3), 47-76.
- Tantrarungroj, P., & Suwannathachote, P. (2012). Enhancing pre-service teacher's self-efficacy and technological pedagogical content knowledge in designing digital media with self-regulated learning instructional support in online project-based learning. *Creative Education*, 3, 77-81. Retrieved from <http://search.proquest.com/docview/1321120865?accountid=25704>
- Tiantong, M., & Siksen, S., (2013). The Online Project Based Learning Model Based on Student's Multiple Intelligence. *International Journal of Humanities and Social Science*, 3(7), 204-211.
- Uitto, A. (2014). Interest, attitudes and self-efficacy beliefs explaining upper-secondary school students' orientation towards biology-related careers. *International Journal of Science and Mathematics Education*, 12(6), 1425-1444. <https://doi.org/10.1007/s10763-014-9516-2>
- Whatley, J. (2012). Evaluation of a Team Project Based Learning Module for Developing Employability Skills. *Informing Science and Information Technology*, 9, 75-92. <https://doi.org/10.28945/1605>
- Zeidan, A. H., & Jayosi, M. R. (2015). Science Process Skills and Attitudes toward Science among Palestinian Secondary School Students. *World journal of Education*, 5(1), 13-24. <https://doi.org/10.5430/wje.v5n1p13>
- Zhao, N., & Wardeska, J. G. (2011). Mini-journal inquiry laboratory: A case study in a general chemistry kinetics experiment. *Journal of Chemical Education*, 88(4), 452-456. <https://doi.org/10.1021/ed100079t>



<http://www.ejmste.com>



<https://twitter.com/ejmste>



<https://www.facebook.com/ejmste>



<http://modestum.co.uk/>



[publications@modestum.co.uk](mailto:publications@modestum.co.uk)



# A Study on College Students' Psychology of Revenge and Interpersonal Forgiveness and the Relationship with Health Education

Zhi-Yong Zhuang<sup>1</sup>, Wei Qiao<sup>2\*</sup>

<sup>1</sup> School of Physical Education, Huaqiao University, Quanzhou, CHINA

<sup>2</sup> Department of Physical Education, Xiamen Institute of Technology, Xiamen, CHINA

Received 20 December 2017 • Revised 1 February 2018 • Accepted 21 March 2018

## ABSTRACT

Psychology of revenge is a psychological tendency to directly damage the interpersonal relationship on university campus, while interpersonal forgiveness is the emotion-focused countermeasure and an effective way to resolve interpersonal conflict. This study concerns about the effect of Health Education on college students' psychology of revenge and interpersonal forgiveness. Total 1321 college students of 14 universities in 10 cities in China are investigated the psychology of revenge, interpersonal relationship, and the relationship with Health Education with questionnaire survey. The research reveals that Health Education could effectively reduce college students' psychology of revenge, effectively promote the interpersonal forgiveness, and significantly enhance the negative effects of interpersonal forgiveness on psychology of revenge. Positively promoting college students' participation in Health Education is an important route to enhance the interpersonal relationship as well as an effective way to construct harmonious university campus.

**Keywords:** college students, health education, psychology of revenge, interpersonal forgiveness

## INTRODUCTION

Along with the development of social economy, the relationship among people in the society becomes more complicated and changes the relatively pure interpersonal relationship on campus; a lot of campus violence is announced by the media (Bhandari & Yasunobu, 2009; Guàrdia et al., 2006). Similarly, violence on university campus is not rare. Such violence is closely related to college students' psychology of revenge, which could directly result in revenge behaviors to influence and damage the relationship among people on campus and in the society and affect the construction of good campus and humanistic environment, and even result in more serious injuries (Hu, Zhang & Zhong, 2005; Jung & Song, 2015). A university is the bridge to connect the school and the society and is the miniature of the society. The reality of university life largely reflects the reality in current society, and various contradictions in the society would appear in the interpersonal relationship on campus. College students are in the youth growth period and present ambiguity on the comprehension of society and interpersonal relationship to appear some special conflict and contradiction (Clammer, 2000; Wu & Tai, 2016). Campus violence would happen because college students, in the special environment of university campus and with the characteristics at the age stage, have limited ways to handle and cope with interpersonal relationship. Such violence appears possible because of college students' psychology of revenge. However, some people might present the psychological tendency completely opposite to the psychology of revenge after being violated, i.e. interpersonal forgiveness. People with such psychological tendency show weaker revenge tendency and might have the motivation to keep positive relationship with the violator (Guàrdia et al., 2006; McCullough et al., 2003; Sloan & Bowe, 2014). Interpersonal forgiveness has been largely studied and is the major factor in people's individual communication (Kim & Oh, 2018; Moorhead, Gill Minton, & Myers, 2012). Being the emotion-focused countermeasure,

#### Contribution of this paper to the literature

- Physical education does not simply present positive effects on college students' physical health, but could remarkably promote the mental health.
- Many college students do not leave houses due to the convenient shopping and payment. Such a situation would seriously affect college students' physical health and might influence the mental health.

interpersonal forgiveness is an effective route to resolve interpersonal conflict. McCullough et al. pointed out interpersonal forgiveness as the change of individual pro-social motivation after being violated, including the reduction of revenge and avoidance motivation as well as the enhancement of benevolence motivation (McCullough, Bono & Root, 2007; Sloan & Bowie, 2014). Research findings showed that interpersonal forgiveness could promote well-being, enhance physical & mental health, and reduce interpersonal conflict, enhance relationship satisfaction (Karremans, Paul & Van Lange, 2008; Wu & Tai, 2016).

The positive effect of Health Education on people's psychology has been generally agreed. A lot of researchers proved the positive effects of Health Education on participants' (especially college students) self-confidence development, interpersonal communication capability development, and social adaptability as well as the function to enhance participants' interpersonal trust ability, induce the potentials, and enhance the social adaptation and perfect personality. Nevertheless, research on the effect of Health Education on college students' psychology of revenge and interpersonal forgiveness is still little. Such research would expand college students' psycho-education tactics and routes, reduce the occurrence of university violence, and advance college students forming good interpersonal relationship.

## RESEARCH HYPOTHESIS

### Health Education Could Significantly Reduce College Students' Revenge Tendency and Remarkably Enhance the Interpersonal Forgiveness

Health Education is the best social education for people venting emotion, the best way to adjust bad mood, e.g. effectively releasing people's depression (Bosscher, 1993), as well as an important method to form good interpersonal relationship (Koo & Lee, 2014). There has not been the special research on the effects of Health Education on college students' psychology of revenge and interpersonal forgiveness. Research found out the positive effect of Health Education on college students' interpersonal relationship and interpersonal trust as well as the remarkably positive correlations between interpersonal trust and interpersonal forgiveness. In other words, increasing trust among people would notably enhance interpersonal forgiveness attitudes and tendency (Krishna, 2014; Wieselquist, 2009). Meanwhile, typically negative correlations existed in between psychology of revenge and interpersonal forgiveness.

Accordingly, the following hypotheses are proposed in this study.

**H1:** Health Education could notably reduce college students' revenge tendency.

**H2:** Health Education could significantly enhance college students' interpersonal forgiveness.

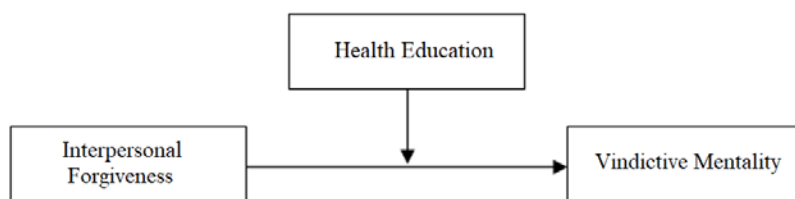
### College Students' Interpersonal Forgiveness Shows Remarkably Negative Predictability on Revenge Tendency, and Health Education Could Notably Enhance the Negative Predictability of Interpersonal Forgiveness on Revenge Tendency

Research revealed that college students and youngsters with higher interpersonal forgiveness tendency would present lower revenge tendency after suffering from interpersonal violation (Hu, Zhang, Ja, Zhong, 2005; Rey & Extremera, 2016). In this case, it is proposed in this study that.

**H3:** College students' interpersonal forgiveness reveals significantly negative predictability on revenge tendency.

What is the function of Health Education on interpersonal forgiveness and revenge tendency? It is stated that Health Education could positively affect interpersonal relationship, enhance interpersonal trust, and reduce people's psychology of revenge; besides, interpersonal trust shows positive correlations with interpersonal forgiveness. For this reason, the following hypothesis is proposed in this study.

**H4:** Health Education, as a moderator, could remarkably enhance the negative predictability of interpersonal forgiveness to revenge tendency.



**Figure 1.** Theoretical model of the moderation effect of physical education

**Table 1.** Analysis of reliability

variable	n	question	$\alpha$ coefficient
psychology of revenge	1210	5	0.82
tendency to forgive	1210	4	0.80
attitudes towards forgiveness	1210	6	0.83
overall scale	1210	15	0.87

## RESEARCH DESIGN

### The Subject

Students of 14 universities in 10 major cities (Beijing City, Shanghai City, Wuhan City, Guangzhou City, Chengdu City, Xian City, Nanjing City, Shenyang City, Nanchang City, and Changsha City) are studied. Total 1400 copies of questionnaire are distributed, and 1321 copies are collected, with the retrieval rate 94.35%, where 1210 copies are valid, with the effective rate 91.60%.

### Survey Tool

The scale used in this study is composed of three subscales of “Transgression Related Interpersonal Motivations Scale” (5 questions), “Tendency to Forgive” (4 questions), and “Attitudes toward Forgiveness” (6 questions).

“Transgression Related Interpersonal Motivations Scale” (TRIM) is made by McCullough et al., mainly to investigate college students’ psychology of revenge. “Tendency to Forgive” (TTF) and “Attitudes toward Forgiveness” (ATF) are made by Brown (2003), mainly to survey college students’ interpersonal forgiveness tendency and attitudes. Aiming at the characteristics of college students in China, the three scales are revised by Hu et al. (2005) to conform to the characteristics of college students in China and present favorable measurement validity.

## RESULT AND ANALYSIS

### Reliability and Validity Test

By calculating the Cronbach  $\alpha$  coefficient (L. J. Cronbach), the internal consistency is tested and the reliability is confirmed. The results show the  $\alpha$  coefficients of psychology of revenge, tendency to forgive, attitudes toward forgiveness, and overall scale being 0.82, 0.80, 0.83, and 0.87, respectively. The  $\alpha$  coefficients of the subscales and the overall scale are higher than 0.80, revealing the reliability achieving the standard (Table 1).

Factor Analysis is applied to test the structural validity of scales. The factor load of psychology of revenge, tendency to forgive, and attitudes toward forgiveness is higher than 0.40, and the cumulative rate of explanation reaches 63.24%, 64.05%, and 66.12% that the 3 scales show better validity.

### Analysis of Common Method Variance

Partial Correlation Analysis, concluded by Podsakoff, MacKenzie, Lee, and Podsakoff (2003), is utilized for testing the significant common method variance (CMV) problem. The partial correlation analysis result reveals remarkable correlation coefficients of variables that the common method variance problem is not obvious in this study.

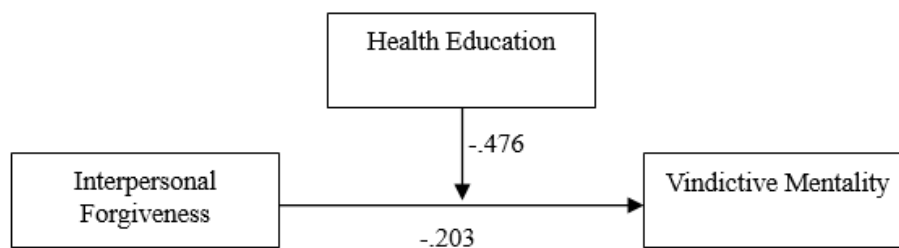
**Table 2.** Regression Analysis of college students' interpersonal forgiveness to psychology of revenge

step	variable	F	R <sup>2</sup>	β
Step 1: control variable	gender	1.442	0.002	0.421
	year			0.383
Step 2: independent variable	interpersonal forgiveness	0.659	0.007	-0.203**

\*\* stands for P<0.01

**Table 3.** Moderation effect of Health Education time on interpersonal forgiveness and psychology of revenge

step	variable	F	R <sup>2</sup>	β
Step 1	gender	1.442	0.002	0.421
	year			0.383
Step 2	interpersonal forgiveness	0.659	0.007	-0.203
	Health Education time			-0.187
Step 3	interpersonal forgiveness×Health Education time	2.572	0.250	-0.476



**Figure 2.** Moderation effect of physical exercise

### Relationship among Health Education, Psychology of Revenge, and Interpersonal Forgiveness

Correlation Analysis is used for investigating the relationship between Health Education and psychology of revenge, interpersonal forgiveness. Time for participating in Health Education in a week is regarded as the indicator of participants' participation degree in Health Education, i.e. the correlation between Health Education time and psychology of revenge, interpersonal forgiveness. The analysis show notably negative correlations between Health Education time and psychology of revenge ( $r=-0.43$ ,  $p<0.01$ ) and significantly positive correlations with interpersonal forgiveness ( $r=0.68$ ,  $p<0.01$ ). It explains that college students participating more in Health Education show the lower psychology of revenge and higher interpersonal forgiveness. H1 and H2 are therefore proved.

### Predictability of Interpersonal Forgiveness to Psychology of Revenge

After controlling the effects of demographic variables, Regression Analysis is applied to test the predictability of interpersonal forgiveness to psychology of revenge. The data analysis reveals negative effects of interpersonal forgiveness on psychology of revenge ( $\beta=-0.203$ ,  $p<0.01$ ) that H3 is proved. Meanwhile, it explains that college students with higher interpersonal forgiveness show lower psychology of revenge after being violated.

### Moderation Effect of Health Education in Interpersonal Forgiveness and Psychology of Revenge

With Hierarchical Regression, the product of moderator and independent dichotomies is included in the regression equation to test the moderation effect of Health Education. Based on the control of demographic variables, interpersonal forgiveness, Health Education time, and interpersonal forgiveness×Health Education time are input to the regression equation. The data analysis shows that the predictability of interpersonal forgiveness×Health Education time to psychology of revenge increases when interpersonal forgiveness and Health Education time are controlled and  $\Delta R^2$  is significant ( $\beta=-0.476$ ,  $\Delta R^2=0.258$ ,  $p<0.01$ ). It presents that Health Education time is the moderator of interpersonal forgiveness and psychology of revenge and could effectively enhance the predictability of interpersonal forgiveness to psychology of revenge. H4 is therefore proved (Table 1, Figure 1).

## DISCUSSION

A lot of research proves the relationship between interpersonal forgiveness and psychology of revenge. This research on college students also discovers that interpersonal forgiveness could effectively reduce college students' psychology of revenge. However, how can college students' interpersonal forgiveness tendency and attitudes be enhanced? The time for the students participating in Health Education every week is regarded as a key variable in this study. The research findings show the notable correlation between Health Education time and psychology of revenge, interpersonal forgiveness, i.e. the longer Health Education time, the higher interpersonal forgiveness and the lower psychology of revenge. Meanwhile, it is discovered that Health Education time could effectively enhance the negative predictability of interpersonal forgiveness to psychology of revenge.

Accordingly, Health Education does not simply present positive effects on college students' physical health, but could remarkably promote the mental health. A lot of college students' mental problems are caused by the handling of interpersonal relationship. University campus is the place where college students, for the first time, leave family and live in the social environment alone. Properly dealing with the relationship with teachers and classmates is the primary basis of interpersonal relationship for college students devoting to the learning. College students with lots of forgiveness could establish good interpersonal relationship network, while those with strong psychology of revenge might be passive in the interpersonal relationship in the university that they might not establish good relationship with others, might result in loss of life and property, or might directly affect personal and others' life development. Having more college students participate more in Health Education could have them vent the negative emotion through Health Education, enhance the interpersonal communication in daily life through interpersonal communication in Health Education, and advance the sensory stimulation to turn away the attention through Health Education so as to effectively reduce the negative psychology of revenge.

Current situation of domestic college students participating in Health Education is worrying. A lot of college students would sit in front of computers after classes. Many college students do not leave houses due to the convenient shopping and payment. Such a situation would seriously affect college students' physical health and might influence the mental health. A university manager therefore has to encourage and promote college students participating in Health Education and has all college students participate in Health Education. College students could enhance the physical quality, shape good psychological quality, and eventually cultivate the lifelong exercise habit through the participation in Health Education.

## REFERENCES

- Bhandari, H., & Yasunobu, K. (2009). What is social capital? A comprehensive review of the concept. *Asian Journal of Social Science*, 37(3), 480-510. <https://doi.org/10.1163/156853109X436847>
- Bosscher, R. J. (1993). Running and mixed physical exercises with depressed psychiatric patients. *International Journal of Sport Psychology*, 24(2), 170-184.
- Brown, R. P. (2003). Measuring individual differences in the tendency to forgive: construct validity and links with depression. *Personality & Social Psychology Bulletin*, 29(6), 759-771. <https://doi.org/10.1177/0146167203029006008>
- Clammer, J. (2000). Cultural Studies/Asian Studies: Alternatives, Intersections, and Contradictions in Asian Social Science. *Asian Journal of Social Science*, 28(1), 47-65. <https://doi.org/10.1163/030382400X00163>
- Guàrdia, J., Freixa, M., Peró, M., Turbany, J., Coscolluela, A., Barrios, M., & Rifà, X. (2006). Factors related to the academic performance of students in the statistics course in psychology. *Quality and Quantity*, 40(4), 661-674.
- Hu, S. M., Zhang, A. Q., & Zhong, H., et al. (2005). A study on interpersonal forgive and revenge of undergraduates and their links with depression. *Psychological Development and Education*, 1, 101-108.
- Jung, K., & Song, M. (2015). Linking emergency management networks to disaster resilience: bonding and bridging strategy in hierarchical or horizontal collaboration networks. *Quality & Quantity*, 49(4), 1465-1483.
- Karremans J., Van Lang, P. A. M. (2008). Forgiveness in personal relationships: its malleability and powerful consequences. *European Review of Social Psychology*, 19(1), 202-241. <https://doi.org/10.1080/10463280802402609>
- Kim, S., & Oh, J. H. (2018). Internet Use and Face-to-Face Social Interaction. *Asian Journal of Social Science*, 46(1-2), 159-181. <https://doi.org/10.1163/15685314-04601008>
- Koo, J. E., & Lee, K. U. (2014). The relationships of elementary school students' sports participation with optimism, humor styles, and school life satisfaction. *Journal of exercise rehabilitation*, 10(2), 111-117.
- Krishna, V. V. (2014). Changing social relations between science and society: Contemporary challenges. *Science, Technology and Society*, 19(2), 133-159. <https://doi.org/10.1177/0971721814529876>

- McCullough, M. E. (2001). Forgiveness: Who does it and how do they do it? *Current Directions in Psychological Science*, 10(6), 194-197. <https://doi.org/10.1037/0022-3514.92.3.490>
- McCullough, M. E., Bono, G., & Root, L. M. (2007). Rumination, emotion, and forgiveness: three longitudinal studies. *Journal of personality and social psychology*, 92(3), 490-505.
- McCullough, M. E., Fincham, F. D., & Tsang, J. A. (2003). Forgiveness, forbearance, and time: the temporal unfolding of transgression-related interpersonal motivations. *Journal of Personality & Social Psychology*, 84(3), 540-557.
- Moorhead, H. J. H., Gill, C., Minton, C. A. B., & Myers, J. E. (2012). Forgive and forget? forgiveness, personality, and wellness among counselors-in-training. *Counseling and Value*, 57(1), 81-95. <https://doi.org/10.1002/j.2161-007X.2012.00010.x>
- Podsakoff, P. M., MacKenzie, S. B., Lee, J. Y., & Podsakoff, N. P. (2003). Common method biases in behavioral research: a critical review of the literature and recommended remedies. *Journal of Applied Psychology*, 88(5), 879-903. <https://doi.org/10.1037/0021-9010.88.5.879>
- Rey, L., & Extremera, N. (2016). Agreeableness and interpersonal forgiveness in young adults: the moderating role of gender. *Terapia Psicológica*, 34(2), 103-110. <https://doi.org/10.4067/S0718-48082016000200003>
- Sloan, A., & Bowe, B. (2014). Phenomenology and hermeneutic phenomenology: the philosophy, the methodologies, and using hermeneutic phenomenology to investigate lecturers' experiences of curriculum design. *Quality & Quantity*, 48(3), 1291-1303. <https://doi.org/10.1007/s11135-013-9835-3>
- Wieselquist, J. (2009). Interpersonal forgiveness, trust, and the investment model of commitment. *Journal of Social & Personal Relationships*, 26(4), 531-548. <https://doi.org/10.1177/0265407509347931>
- Wu, T. J., & Tai, Y. N. (2016). Effects of multimedia information technology integrated multi-sensory instruction on students' learning motivation and outcome. *EURASIA Journal of Mathematics, Science and Technology Education*, 12(4), 1065-1074. <https://doi.org/10.12973/eurasia.2016.1552a>

<http://www.ejmste.com>



## Development of a Remote Laboratory Infrastructure and LMS for Mechatronics Distance Education

Ayça Ak <sup>1\*</sup>, Vedat Topuz <sup>1</sup>, Aysun Altıkardes <sup>1</sup>, Bekir Oral <sup>1</sup>

<sup>1</sup> Marmara University, Vocational School of Technical Sciences, Istanbul, TURKEY

Received 1 November 2017 • Revised 7 March 2018 • Accepted 26 March 2018

### ABSTRACT

The problem in schools with mechatronics programs is not only their low student capacity but also their theoretical-content-dominated curricula. However, the manufacturing industry needs highly-talented technical personnel with a lot of practice in this field. E-Learning Education for Mechatronics Remote Laboratory, EDUMEC, offers practical-content-dominated courses over the Internet. The situations and expectations of the target groups were designated using surveys to constitute the educational concepts for the e-mechatronics program and experiments. The target groups are students in vocational schools or engineering classes; engineers or technicians who have completed formal education in mechanical engineering, electrical/electronic engineering, or other technical fields; employers; and teachers. For training, a special multi-lingual e-learning platform has been built in a user-friendly environment with a Learning Management System (LMS). This paper presents the design and implementation of the remote laboratory and LMS. In addition, evaluations by the students who participated in the training are presented.

**Keywords:** e-learning, mechatronics, online education, remote laboratory

### INTRODUCTION

The term “mechatronics” was popularized as technical terminology by a Japanese company, Yaskawa Electric Corporation, and since 1971, it has been protected as a trade name. In the early period of its use, mechatronics was understood as the design and construction activities concerning the inclusion of electronics and systems to the functional structure of various precision mechanisms. Mechatronics is an approach to engineering design that integrates mechanical, electrical and electronic, and computer engineering for a wide range of products and processes.

High-quality mechatronics education is important because there is a clear correlation between a company’s economic power and the promotion and development of its junior staff. To be able to persist in global competition, a company requires a well-educated workforce. Engineers must be able to work in interdisciplinary teams, which generally have a multi-cultural composition, and may even be located in distributed places. Specifically, workers must know integrated methodology and design of not only products but also projects and processes. This shift away from traditional work and organizational models toward teamwork and inter-disciplinary projects requires an opposite consideration and response in the form of education (Welp, Labenda, & Jansen, 2006).

A major goal of mechatronics education is to instill students with theoretical operational knowledge as well as practical competencies in the core technical skills. There is a growing need for qualified service personnel in mechatronics, rather than in pure mechanics or pure electronic control technologies (Shetty, Kondo, Campana, & Kolk, 2002).

A well-educated high-performance workforce that possesses practical skills is difficult to assemble in today’s world of rapidly changing technology, especially in the electro-mechanical and mechatronics fields. The traditional practice in enterprises globally is to provide training/retraining to their employees via conventional in-company

#### Contribution of this paper to the literature

- A model for practical training of advanced and industrial areas that requires expensive equipment using innovative remote laboratory.
- The development of educational model by content analysis for the online Mechatronics education.
- Multi-lingual special E-learning platform in the user friendly environment with Learning Management System.

training, which can be organized by themselves internally, by hired educators or, quite often, by the producers of the industrial equipment. In the European Union (EU), 38% of the companies rely on such internal training. However, a closer look shows that not all employees participate in such training owing to family responsibilities (40%) or a conflict with their work schedule (39%) (Ferreira & Müller, 2004). It is clear that this training approach usually does not accommodate the individual needs of practicing engineers and technicians. Further, this approach usually does not leverage communications technology and distance learning to accommodate different learning styles.

Aside from in-company training, many other sources of continuing education are used today. Statistically, 32% of the total population in the EU consults the Internet for self-directed learning. However, the use of the Internet to attend online courses is relatively low, reaching only 5% in this group in 2010. Additionally, this rate is growing slower than expected, increasing by only 2 percentage points from 2007 to 2010 (Eurostat, 2013).

E-learning methods are similarly used infrequently for in-company training in the electro-mechanical-mechatronics industry. Experiments that can be conducted remotely are essential for training technicians and practicing engineers in technical professions.

In the field of mechatronics, various remote experiments and remote laboratories have been developed (Basso & Bagni, 2004; Casini, Prattichizzo, & Vicino, 2004; Castellanos, Hernandez, Santana, & Rubio, 2005; Corradini, Ippoliti, Leo, & Longhi, 2001; Gadzhanov, Nafalski, & Nedic, 2014; Hercog, Gergic, Uran, & Jezernik, 2007; Ko et al., 2005; Salzmann, Gillet, & Huguenin, 2000; Sanchez, Dormido, Pastor, & Morilla, 2004; Tan, Lee, & Leu, 2000; Valera, Diez, Valles, & Albertos, 2005). Most of these studies provided training in only a limited number of experiment facilities through a single set. In addition, most of these studies utilized the LabVIEW or MATLAB platform. The number of studies offering both training opportunities and experiments is very low. The study by Xu et al. (2013) is unique in that the authors introduced an Internet-based remote-controlled robot crossover project through an international cooperative program based in Japan, China, Thailand, and Taiwan.

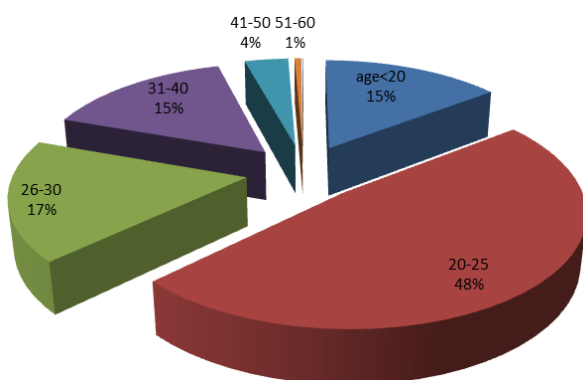
Rojko et al. (2011) had represented the Merlab project in their study. In Merlab project the training, special E-learning platform has been built in the user-friendly environment, which is based on a combination of commercial eCampus platform and open-source Moodle platform. The sets in the Merlab project are two degrees of freedom SCARA robot and a servo motor. Rodriguez et al. (2015) presented hardware and software architecture for developing educational laboratories by connecting real programmable logic controllers (PLCs) to virtual industrial plants. Fernandez et al. (2015) demonstrated how using mechatronics and robotics in distance education can be a motivational tool to promote retraining for people of all ages who received minimal training during engineering.

The “E-Learning Education and Innovative Remote Laboratory for Mechatronics” project, which we call EDUMEC, was co-funded by the European Union Lifelong Learning Program called Leonardo da Vinci Transfer of Innovation Action. This project was conducted by eight project partners under the leadership of Marmara University Vocational School of Technical Sciences. The other project partners are Festo, Çizgi-Elektronik, and TEGEV from Turkey; the University of Versailles Saint-Quentin-en-Yvelines and the Université de Technologie de Belfort-Montbéliard from France; Zavod Prava Poteza from Slovenia; and the Czech Republic VSB - the Technical University of Ostrava from the Czech Republic.

The main aim of the EDUMEC project is to introduce good practices into vocational training in mechatronics related to national and international qualifications. To realize this goal, we leveraged information and communication technologies (ICT) and established methodological as well as didactic approaches. All training materials were prepared according to levels 3, 4, 5, and 6 of the European Qualifications Framework (EQF).

The EDUMEC project is unique compared with similar studies owing to the following novel aspects:

- Multilingual Web portal (English, Turkish, Czech, Slovenian, and French),
- Innovative real-time control platform (RTCP),
- Up-to-date remotely controlled laboratory (RCL),
- Multilingual pedagogical course books for self-learning,
- The opportunity for advanced and industrial learning with three experimental sets.



**Figure 1.** Age distribution of student participants

Anyone who wants to improve their technical knowledge/skills can benefit from the educational opportunities offered by this project free of cost. Membership is compulsory to participate in this project and get an appointment to perform experiments using the appointment system.

Analyses of the knowledge and skills requested by students and trainers are presented in Section II. The infrastructure of e-learning mechatronics education in the remote laboratory is shown in Section III. Section IV presents the evaluations by the students who participated in the EDUMEC program. Finally, the conclusions are given in Section V.

## ANALYSIS OF THE SITUATION AND CONCEPTUAL DEVELOPMENT

The first important part of the EDUMEC project is analyzing the situation and conceptualizing the educational approach. The analysis included situation analysis and evaluation of the pre-requirements for implementing development education in vocational education and relevance of the European labor markets, identification of stakeholders, exchange of good practices and concepts for module development and development of an e-mechatronics program.

In this part of the project, an analysis of needs concerning knowledge and skills as requested from industrial partners was conducted. The goal was to analyze the cognitive and formative knowledge of the target groups, analyze learning levels and explore advantages and disadvantages of the methods and content applied to the in-house training of partners. Finally, an analysis of the needs related to education methods in in-house training was performed.

For the situation analysis and the evaluation of requirements, questionnaires were distributed to students and teachers in three countries: Turkey, France, and Slovenia. More than 1,000 students participated in the survey. Female participants constituted only 10% of the survey participants. The age distribution of the participating students is shown in [Figure 1](#).

Almost 450 of the surveyed students had earned a Bachelor's degree. The second-most frequent educational level was vocational and high school. Nearly 70% of the survey participants had consistent employment and just over 200 participants had part-time employment or were freelancers. Most of the students who participated in the survey expressed an interest in mechatronics, IT, software engineering, electronics and robotics ([Figure 2](#)).

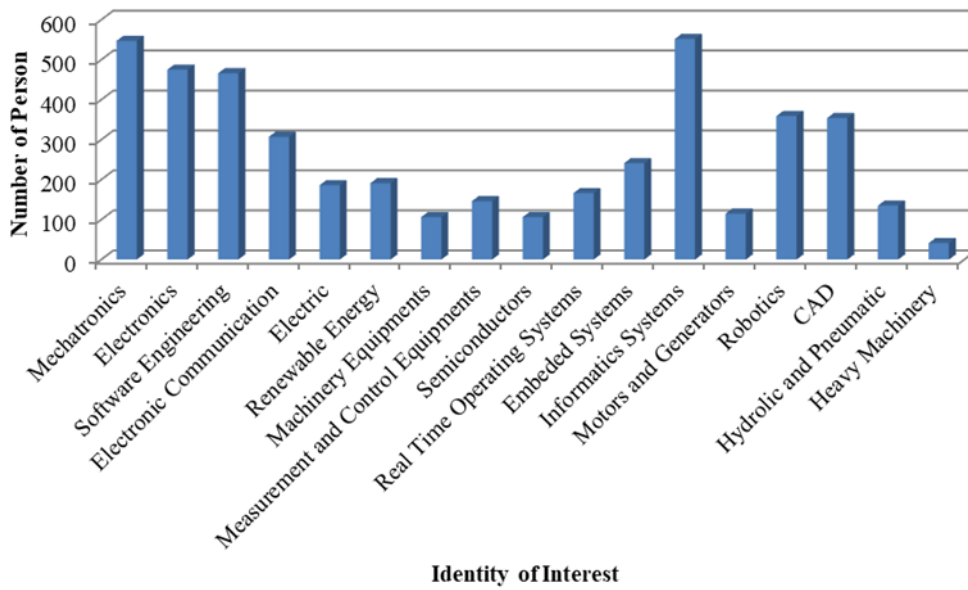


Figure 2. Interest in various fields

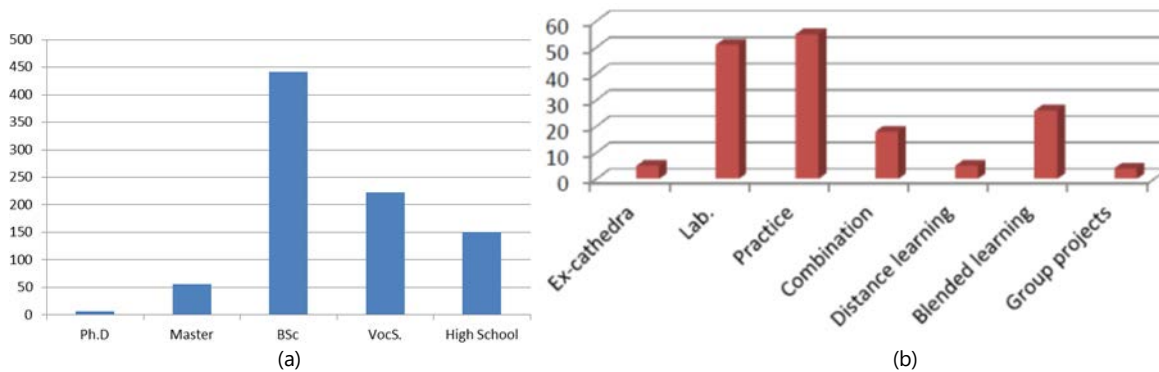


Figure 3. (a) Educational level and (b) Most commonly used learning styles in the participating organizations

More than 600 of the student participants believed that they were able to find and select information from various sources such as the Internet. Nearly 60% of the students stated that they could quickly adapt to new working methods and technologies: around 20% reported that they are good at adapting and only a minority thought their adaptation abilities were unsatisfactory. Just above 50% of the participants agreed that they are very good at multi-tasking and another 20% reported that they are good at this skill.

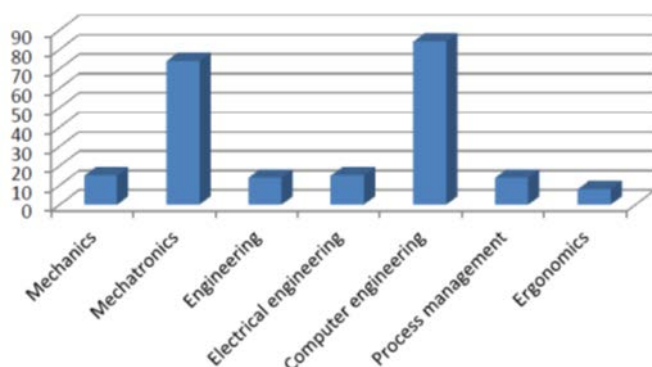
Nearly 65% of the student participants reported that they are very good at using hardware equipment and another 30% responded that they were good at it. More than 800 students reported that they are very good or good at using selected word-processing programs. Nearly all the participating students responded that they are good or very good at using e-mail. Only a minority of students said that they do not have skills in searching the Internet. 85% of the students said that they are active in at least one Internet forum/chat room. 96% of the students had personal computers with an Internet connection at home. Nearly half of the students had already participated in an e-learning course and most of these found it useful. 71% of the participants had already participated in informal training programs that were not part of their formal education.

More than 75% of the participants had never operated a mechatronic device through the Internet. There are various reasons for not participating in e-learning courses, including more than 520 students reporting that no such course had been organized until then; 11% said the reason was lack of time, about 5% said the training schedule did not fit their working obligations, and another 5% was not interested in such education.

In the questionnaire for educators/teachers, 183 people responded. Most of the participating organizations had over 700 students. The educational levels of these organizations are shown in Figure 3a. The most commonly used learning styles in these institutions are shown in Figure 3b; the most frequent responses were practice, laboratory work, and blended learning.

**Table 1.** Preferred Lessons

Name of the Course	Definitely Should (5)	(4)	(3)	(2)	(1)	Definitely Should Not(0)
Fundamentals of Electrical Engineering	18%	8%	13%	10%	8%	43%
Fundamentals of Mechanical Engineering	13%	6%	12%	10%	5%	50%
Mechatronic Systems and Devices	30%	15%	11%	6%	8%	33%
Introduction to Automation	24%	14%	12%	8%	8%	37%
Introduction to Robotics	31%	14%	12%	5%	4%	34%
Applied Sensor Systems	20%	11%	13%	6%	4%	46%
Applied Control Systems Theory	14%	9%	13%	6%	5%	53%
Servo Drives	12%	7%	12%	7%	6%	57%
Power Electronics	12%	19%	11%	6%	6%	57%
Electrical Circuits	16%	12%	11%	8%	4%	49%
Digital Systems	22%	13%	11%	5%	3%	46%
Industrial Robots	17%	9%	10%	6%	4%	54%
Robot Programming	32%	11%	10%	5%	3%	38%
Micro Controller and Embedded Systems	24%	8%	10%	6%	4%	48%
Signal and Image Processing	16%	10%	11%	7%	4%	52%
Building Management Systems	9%	7%	11%	7%	5%	61%
Computer Aided Measurement and Control	21%	8%	11%	8%	4%	43%
Manufacturing Technology	11%	6%	12%	13%	8%	58%
Materials Science	8%	8%	9%	8%	6%	61%
Engineering Software	31%	13%	10%	7%	3%	37%
PLC Controllers and Industrial Networks	15%	9%	11%	7%	4%	54%
Artificial intelligence	30%	12%	11%	6%	4%	36%
Emerging / Alternative Technologies	33%	12%	10%	4%	2%	39%

**Figure 4.** Areas for the planned remote laboratories

Participants were asked which course they would prefer to take for 23 lessons. They were asked to rate each option from 0 to 5 based on their preference. The students were mostly interested in the following courses: Mechatronics Systems and Devices, Introduction to Robotics, Robot Programming, Engineering Software, and Artificial Intelligence and Emerging/Alternative Technologies (**Table 1**).

Nearly half of the participating organizations had no plans of adopting distance learning, and nearly 40% of them had not considered distance learning as an option. The major concerns regarding the introduction of distance learning were costs, technical possibilities, and lack of interest from students. Almost 74% of the participating organizations had planned to introduce remote laboratories into their educational process, largely in the areas of mechatronics and computer engineering (**Figure 4**).

Planning for remote laboratories was most common in technical vocational schools, vocational higher-education institutions, and universities (bachelor's degree level) (**Figure 5**).

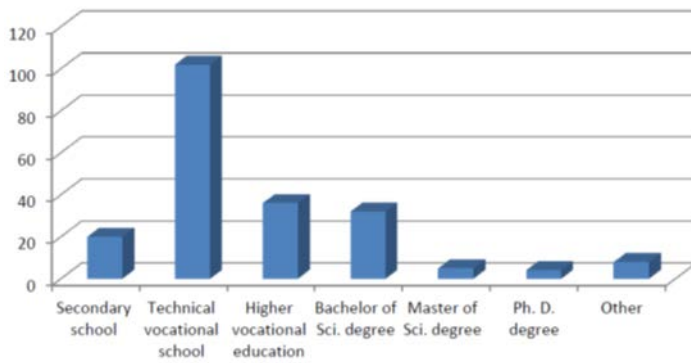


Figure 5. Educational levels for the planned remote laboratories

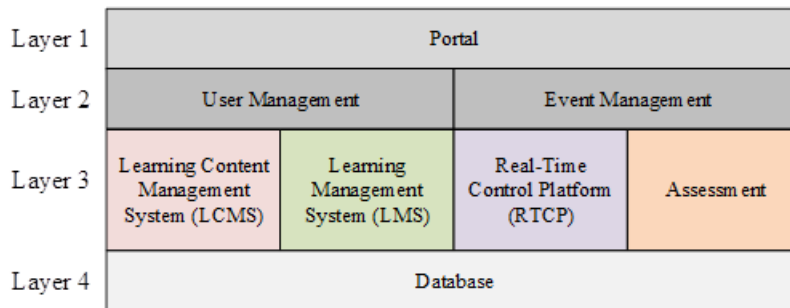


Figure 6. Training model

## INFRASTRUCTURE OF PROJECT

The realized project-training model is based on the UKeU e-Learning framework (Habraken, 2008). As shown in the Figure 6 the framework is built using four layers. Each layer describes the services that perform specific tasks in a certain area of the e-Learning solution.

*Layer 1: Portal* - The portal provides a single port of entry for the users to the different services in the e-Learning framework and is responsible for the authentication of the users. The user can access more than fifty books, job advertisements, and announcements using this portal. List of courses is given in the Appendix. The course books were selected based on the responses to the questionnaire shown in Table 1. All the books were pedagogical self-learning-directed texts written at EQF levels 4, 5, and 6 in five different languages (English, Turkish, French, Czech, and Slovene). The homepage of the Web portal is shown in Figure 7.



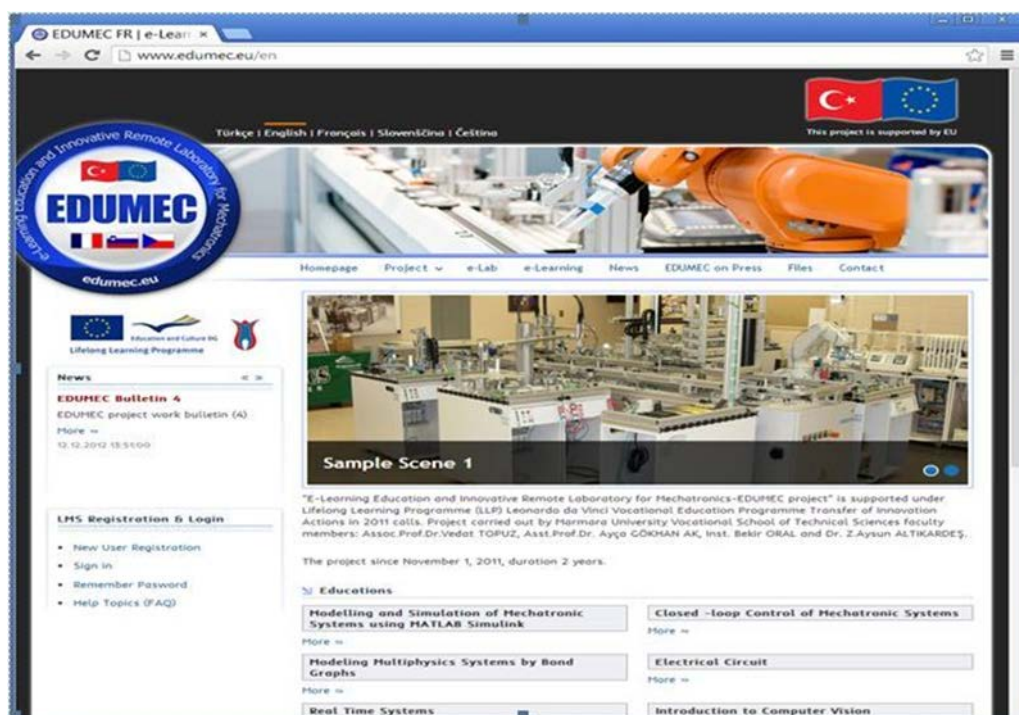


Figure 7. The homepage of the EDUMEC Web portal

*Layer 2: Common Services* - They do not perform any pedagogical function. While User Management service authorizes users and assigns privileges to every user, Event Management services provide scheduling and reminder functions for users.

*Layer 3: Learning Services* - These services provide the core functionality for e-Learning solutions. This layer determines four different services. In Learning Content Management System (LCMS) module, lectures prepared by instructors in PDF, PowerPoint or Flash format are uploaded to the system. It is also possible uploading the videos in AVI or MPEG format via this module. Learning Management System (LMS) is a service which registers users, tracks courses in the catalog, records data from learners and provides searching and reporting capabilities to users of the service. A multilingual real-time LMS has been designed and implemented to manage the Web-based asynchronous training offered. This system is based on a robust architecture that connectivity with the RTCP. The LMS logs and reports detailed data (such as date and place of attendance, courses and exams taken, scores on exams, and performed experiments) for each registered user. These reports were used to generate an "EDUMEC Certificate of Achievement" for the user.

Three different users are defined in the LMS system. These are:

- Trainee*: The trainees only attend classes, exams and practices, and make appointments for experiments.
- Instructor*: They can add lessons to the system in the course module or questions and answers to the exam pool in the exam module. In the experiment module, they can follow the experiment live and interfere with the experiment if desired.
- Administrator*: Admin can give the instructors relevant authorities; query the progress of the course attendees and observe the progress of the trainee according to the exam result. He/ she also prepare the certificate of achievement.

**Assessment.** Assessment System is a service which measures students' performance against specific goals. Through this module, trainees are examining over the internet. Examination dates and times can be determined by the country/teaching staff of the course. The questions of the exams are determined randomly for each trainee according to the difficulty of the questions entered into the system by instructor. When a trainee enters more than one test, he or she is faced with different questions. It is also allowed to enter an exam for one course only once in a day. The courses and durations attended by trainees are controlled via the LMS system. Trainees who do not have the minimum attendance period to the course are not allowed to enter the exam at the end of the course. The success criterion is to have participated in the courses in the specified time period and to obtain a success rate of 60% from the online examination.

**Real-Time Control Platform (RTCP).** In the EDUMEC project, according to the training model, experiments are conducted in real time. For this purpose, an infrastructure was constructed to enable real-time and remote

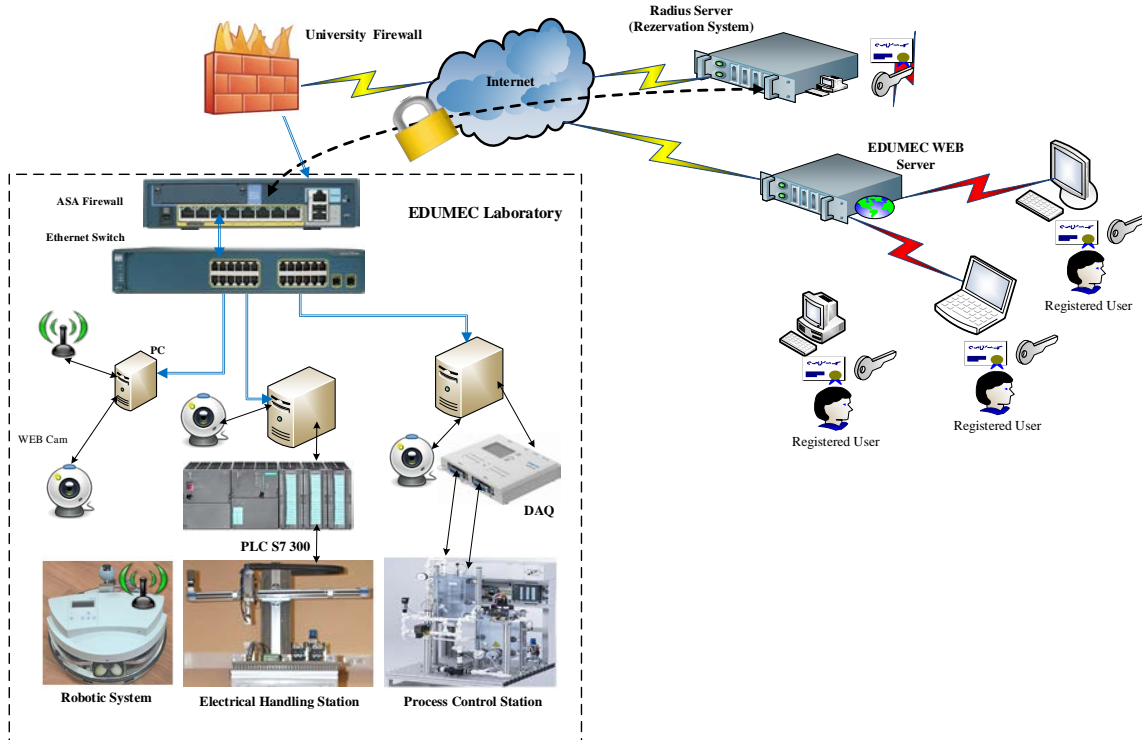


Figure 8. Remote laboratory network infrastructure

e-Lab Reservation

« Mart 2014 »

Pt	Sa	Ça	Pe	Cu	Ct	Pz
24	25	26	27	28	1	2
3	4	5	6	7	8	9
10	11	12	13	14	15	16
17	18	19	20	21	22	23
24	25	26	27	28	29	30
31	1	2	3	4	5	6

**New Reservation**

Experimental Platform:

Reservation Date:

Start Time:

Duration of Use:

Server Time: 31 Mart 2014 16:20 Server Time: 31 Mart 2014

e-Lab platforms, every day on weekdays 10:30 to 16:30 serving to

Lab 1	Lab 2	Lab 3

10:30 11:00 11:30 12:00 12:30 13:00 13:30 14:00 14:30 15:00 15:30 16:00 16:30

**Reservations**

No reservation made for today.

Figure 9. Reservation interface

experiments. The EDUMEC remote laboratory network infrastructure was based on client-server architecture; the structure is illustrated in Figure 8. In this connection, the users provide the virtual private network (VPN) connection to the system via a remote procedure call (RPC) protocol. The system provides a reservation, based on available days and time slots, to the user to enable the performance of experiments. The system security is provided by the VPN connection created by a Cisco ASA Firewall.

Three mechatronic sets have already been established in the RTCP. However, the physical infrastructure is designed to support many more experimental platforms. To use the experiment sets, users follow these steps:

1. Download and install the e-Lab VPN-Client application.
2. Make a reservation using the Web portal e-LAB reservation system. Then, the Radius server generates a unique number to maintain a VPN connection. This unique number used for remote desktop (RDP) connections using the VPN-Client application (Figure 9).

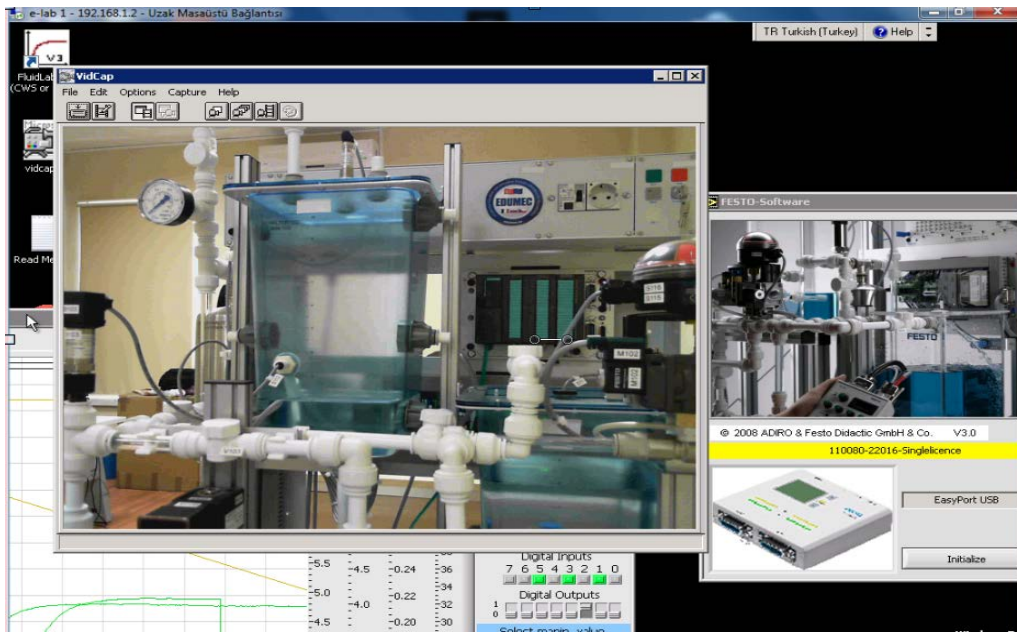


Figure 10. Remote access to the process control unit

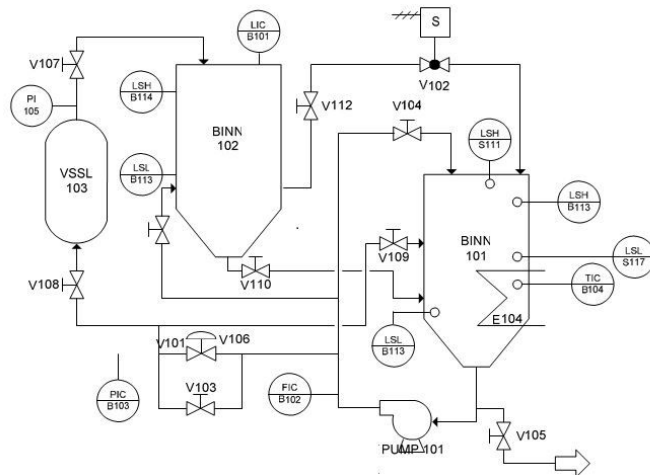


Figure 11. P&ID diagram of the process control unit

- At the reserved time, a VPN connection is established via the VPN-Client application, which uses an RDP in the background.

### Remotely Controlled Laboratory

In this project, three experiment sets were used to form a remotely controlled mechatronic laboratory, selected based on the users' preferences given **Table 1**: a process control set, mobile robot, and electric and pneumatic handling system. Users can remotely conduct experiments related to different aspects of mechatronics and control areas using these training sets.

**Process control set.** In this set, four types of process control experiments (liquid level control, flow control, pressure control, and temperature control) can be performed via remote connections to a PLC or a computer and a data acquisition (DAQ) board. The remote system during real-time Web-based control is shown in **Figure 10**.

A detailed picture and PI diagram of the process control system are respectively shown in **Figure 11**.

The process control system consists of the following components: BINN 102 and BINN 101: Upper and lower tanks; PIC/B103: Controller: (PLC or DQA board and PC); Pump 101: Centrifugal pump; V106: Proportional valve; V 102: Two-way ball valve with pneumatic rotary drive; LIC/B101: Ultrasonic level transmitter; LSH/B114, LSL/

**Table 2.** Experiments for process control

Experiment	Objectives
Project planning	<ul style="list-style-type: none"> <li>• Draw up a PI diagrams for a controlled system.</li> <li>• Draw an Instrument loop diagram of a controlled system.</li> </ul>
Analysis of the tank	<ul style="list-style-type: none"> <li>• Calculation of container volume.</li> </ul>
Analysis of a pump	<ul style="list-style-type: none"> <li>• Determining the delivery rate of a pump.</li> </ul>
Analysis of a proportional valve	<ul style="list-style-type: none"> <li>• Determining the flow rate of a proportional valve.</li> </ul>
Analysis of a heating element	<ul style="list-style-type: none"> <li>• Operation of a heating element.</li> </ul>
Analysis of an ultrasound sensor	<ul style="list-style-type: none"> <li>• Recording the characteristic of an ultrasound sensor.</li> </ul>
Analysis of a flow meter	<ul style="list-style-type: none"> <li>• Recording the characteristic of a flow meter.</li> </ul>
Analysis of a pressure sensor	<ul style="list-style-type: none"> <li>• Recording the characteristic of a pressure sensor.</li> </ul>
Analysis of a temperature sensor	<ul style="list-style-type: none"> <li>• Recording the characteristic of a temperature sensor.</li> </ul>
Commissioning a level-controlled system	<ul style="list-style-type: none"> <li>• Determining the operating range and operating point of a controlled system.</li> </ul>
Commissioning a flow controlled-system	<ul style="list-style-type: none"> <li>• Determining the operating range and operating point of a controlled system.</li> </ul>
Commissioning a pressure-controlled system	<ul style="list-style-type: none"> <li>• Determining the operating range and operating point of a controlled system.</li> </ul>
Commissioning a temperature-controlled system	<ul style="list-style-type: none"> <li>• Determining the operating range and operating point of a controlled system.</li> </ul>
Identification of a controlled system.	<ul style="list-style-type: none"> <li>• Determining the time response of a controlled system.</li> <li>• Determining operation of a controlled system with P controller.</li> <li>• Determining operation of a controlled system with a PI controller.</li> <li>• Determining operation of a controlled system with a PD controller.</li> <li>• Determining operation of a controlled system with a PID controller.</li> <li>• Controller setting using the Ziegler-Nichols method.</li> </ul>

B113, and LSH/B113: Capacitive proximity switches; VSSL 103: Pressure control tank; PI 105: Pressure transmitter; FIC/B102: Flow transmitter; E104: Heating element; and TIC/B104: Thermistor.

The tank level control system is a closed-loop control system equipped with a reservoir tank and a pump motor subsystem. Based on the assumption that the system is either linear or linearized, the differential equation of this system can be obtained as follows:

$$Cdh = (q_i - q_o)dt \quad (1)$$

where  $C$  is the capacitance of the tank ( $m^2$ ),  $h$  is the tank liquid level (m), and  $q_i$  and  $q_o$  are the tank inlet and outlet flow rates, respectively ( $m^3/sec$ ). Thus (Macancela & Canizares, 2014),

$$Gp(s) = \frac{H(s)}{Qi(s)} = \frac{0.02544}{s + 0.005697} \quad (2)$$

The experiments designed to teach users about process control are given in [Table 2](#).

The main purpose of the experiment set is to teach the following skills to the user:

- Working on different process control systems (i.e., liquid level, flow, pressure, and temperature). These processes can be operated individually or as batch processes using manual valves on the set.
- Understanding the process control P&ID diagrams. The system can be diagnosed by following the P&ID diagrams.
- Modeling the behavior of the system. The experimental set allows experiments on all input-output models in the system. Thus, the relationship between the mathematical model and the input-output models can be analyzed.
- Understanding the working principles of different sensors and actuators. There are several types of sensors (pressure, ultrasonic, proximity, and temperature) as well as electrical and pneumatic actuators.
- Controlling the system using a classic ON/OFF or PID controller. Parameters of the controllers can be determined easily using a computer. Thus, the effects of parameter changes on the system performance can be examined.

**Mobile Robot.** The mobile robot has an embedded PC controller (an I/009 control board with an FPGA) and a microcontroller connected via an Ethernet interface ([Figure 12](#)). The mobile robot has nine distance sensors, two optical sensors, two proximity sensors, and a camera. Additional features can be included in the structure using the electrical input and output ports.





Figure 12. Mobile robot (photo from Robotino manual (Bliesener et al., 2007))

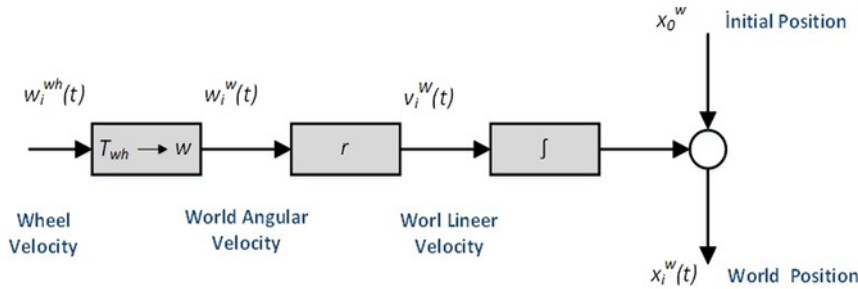


Figure 13. Kinematic model of the mobile robot

The mobile robot uses three engines developed for the Omnidrive drive units. The three drive units allow for motion in all directions—forward, backward, and sideways—and the robot can also turn within its own diameter. Figure 13 shows the kinematic model of the robot.

The kinematic model of the robotino is:

$$\begin{bmatrix} w_1(t) \\ w_2(t) \\ w_3(t) \end{bmatrix} = \frac{1}{r} \begin{bmatrix} v_1(t) \\ v_2(t) \\ v_3(t) \end{bmatrix} = \frac{1}{r} \begin{bmatrix} -\sin(\phi_1) & \cos(\phi_1) & R \\ -\sin(\phi_2) & \cos(\phi_2) & R \\ -\sin(\phi_3) & \cos(\phi_3) & R \end{bmatrix} \begin{bmatrix} \dot{x}_r(t) \\ \dot{y}_r(t) \\ \Omega(t) \end{bmatrix} \quad (3)$$

Here  $w_i$  is the angular velocity of each individual wheel,  $v_i$  is the translational velocity of each individual wheel,  $r$  is the wheel radius,  $R$  is the distance from the center of the robot to the center of wheel,  $x_r$  and  $y_r$  characterize the robot coordinate system,  $\Omega$  is the tangential rotational velocity of the robot, and  $\phi_i$  describes the rotation of the wheel shaft relative to the robot coordinate system equation:

The robot velocity can be determined from the wheel velocities by inverting the above matrix. Equation (3.4) can be simplified by replacing the transformation matrix from the wheel velocities to the world angular velocity with the matrix  $T_{wh \rightarrow w}$ . The world velocity of the robot can be determined from the measurements of the angular velocities of the three wheels by inverting the matrix  $T_{wh \rightarrow w}$ . Thus, the estimated position after moving the robot from time  $t_0$  to time  $t_1$  is determined using the following equation:

$$\begin{bmatrix} x_w(t_1) \\ y_w(t_1) \\ \theta(t_1) \end{bmatrix} = \begin{bmatrix} x_{w,0} \\ y_{w,0} \\ \theta_0 \end{bmatrix} + r \cdot \int_{t_0}^{t_1} [T_{wh \rightarrow w}]^{-1} \begin{bmatrix} w_1(t) \\ w_2(t) \\ w_3(t) \end{bmatrix} dt \quad (4)$$

where  $x_w(t_1)$  and  $y_w(t_1)$  are the coordinates in the world coordinate system at time moment  $t_1$ ,  $\theta(t_1)$  is the orientation angle at time  $t_1$ ,  $x_{w,0}$  and  $y_{w,0}$  are coordinates in the world coordinate system at time  $t_0$ , and  $\theta_0$  is the orientation angle at time  $t_0$  (Oltean, Dulău, & Puskas, 2010).

The mobile robot can be programmed with Robotino View software installed on a computer that is accessed via a wireless LAN connection. Because the mobile robot has its own Linux operating system, the user can directly control the omnidrives using Telnet connections. The wheel units have an angle degree of 120 between each other. Robotino View can transmit signals to the motor controller in addition to displaying, changing, and evaluate sensor values. The mobile robot can even be programmed during actual operation via Robotino View (Figure 14).

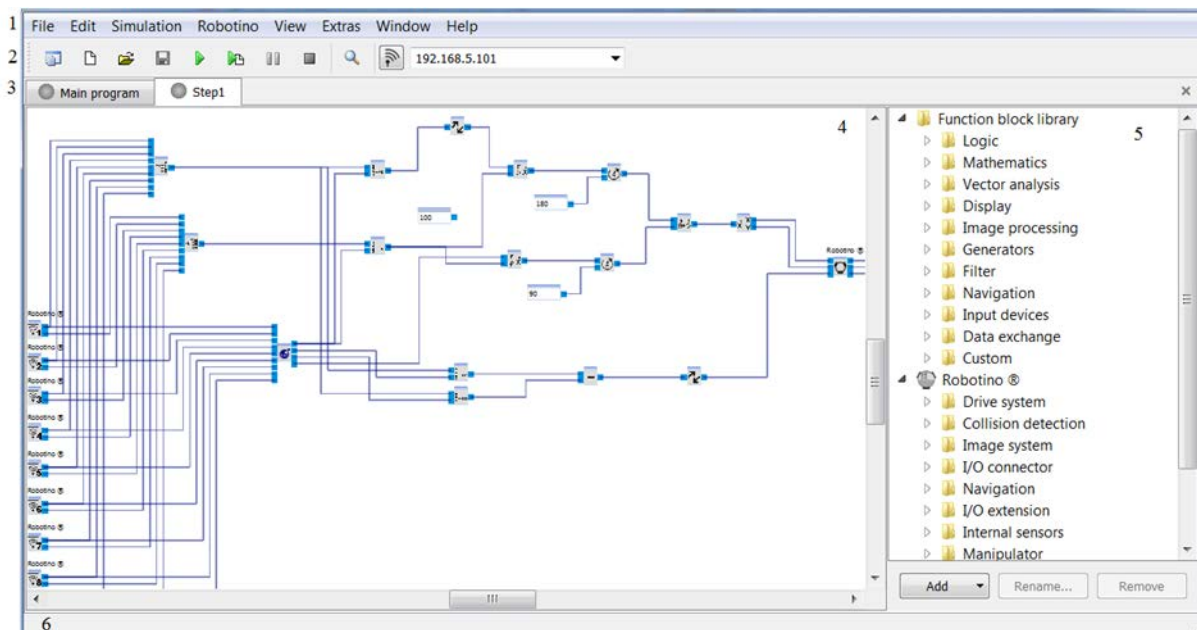


Figure 14. Robotino View

Table 3. Experiments for robot control

Experiment	Objectives
Analysis of Mobile Robot	<ul style="list-style-type: none"> <li>Electrical motor control learning the mechanical construction of a mobile robot system.</li> </ul>
Remote control and programming of the mobile robot	<ul style="list-style-type: none"> <li>Learning remote control and basic functions of graphical programming software</li> </ul>
Linear running of mobile robot in any direction	<ul style="list-style-type: none"> <li>Commissioning of a mechatronic system</li> <li>Learning electrical motor control</li> </ul>
Omnidrive	<ul style="list-style-type: none"> <li>Learning electrical motor control/drive unit</li> </ul>
Acquisition and scaling of sensor data	<ul style="list-style-type: none"> <li>Learning collision protection</li> </ul>
Search and approach	<ul style="list-style-type: none"> <li>Learning closed-loop control of a mechatronic system</li> </ul>
Line follows	<ul style="list-style-type: none"> <li>Graphics programming applications for a mobile robot system</li> </ul>
Wall follow, search and approach, color tracking	<ul style="list-style-type: none"> <li>Analysis of sensor data for various applications</li> </ul>

In the Robotino View interface, 1 is the menu bar that contains menus to perform actions such as load/save, edit, view. 2 is the tool bar containing quickly accessible buttons to perform some of the functions from the menus, buttons to start and stop the simulation, an input box for Robotino IP address, and a connect button. In the program selector section (3), the user can switch between the main program and the subprograms of a project. The subprogram "Step1" is visible in Figure 13. 4 is the program workspace, where the program is viewed and edited. The library of function blocks available for programming is labeled 5. The status bar (6) shows information about the project and the application status.

After learning the basic principles of the mobile robot, the experimental stage can commence. A list of experiments starting from simple tasks and extending to complex applications is shown in Table 3. However, the applications that can be developed with the mobile robot are not limited to this list; after the experimental stage, the user may develop further applications.

**Electrical and Pneumatic Handling Station.** Material flow is a sub-function of the handling station. Additional sub-functions are conveying and storing. Users who access the computer remotely via a VPN can run the PLC software using Simatic Manager through a multi-point interface (MPI) adapter. The electrical handling station is equipped with a flexible two-axis handling device. The inserted workpieces are detected in the retaining device by an optical reflex light sensor.

The electrical handling device fetches the workpieces from the retaining device with the help of a pneumatic gripper that is fitted with an optical sensor. The sensor differentiates between "black" and "non-black" workpieces. The workpieces can be deposited on different slides based on these criteria. The electrical handling station comprises a receptacle module, a PicAlfa module, a slide module, a profile plate, a trolley, a control console, and a PLC board (Figure 15).



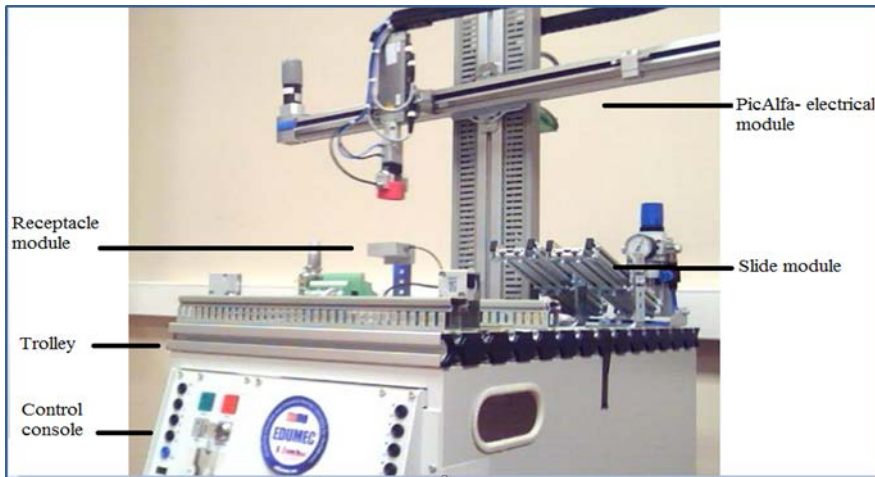


Figure 15. Electrical handling station

Table 4. Experiments for electrical handling station

Experiment	Objective
System activations	<ul style="list-style-type: none"> <li>Understanding fully by analyzing the scheme of Electrical Handling Station</li> <li>Learning fundamentals of Programmable Logic Circuit using S7- 300</li> </ul>
	<ul style="list-style-type: none"> <li>Learning the connection of electrical handling station to the computer by using PLC-S7 PC-adapter with USB/MPI converter.</li> <li>To control start and stop activities.</li> </ul>
	<ul style="list-style-type: none"> <li>To make an error detection</li> </ul>
	<ul style="list-style-type: none"> <li>To perform emergency stop system.</li> </ul>
Separating of the different components	<ul style="list-style-type: none"> <li>To make an error detection</li> <li>To perform emergency stop system.</li> </ul>

The electrical and pneumatic handling station is designed to improve the user’s PLC programming knowledge. Users can create a scenario using electrical or pneumatic actuators according to the signals coming from different sensors and switches. Experiments built on the electrical and pneumatic handling station are listed in **Table 4**.

A connection is made between the test set and the computer via a PLC-S7 PC adapter with a USB/MPI converter by clicking on the monitor on/off button in the toolbar. OB1 is the main organization module. The process orders of the other programs and data modules are assigned in this main module. In emergencies, such as an electrical short, loss of Internet connection, and other faults, the emergency stop module is activated and the entire system stops. In the case of an emergency stop the emergency stop program block is called which resets the operating panel outputs and station outputs.

### Evaluation of the System

A total of 41 persons participated to the pilot training for the EDUMEC project and 25 persons successfully completed it. Pilot training was attended by Computer, Electrical, Electronics and Mechatronics students at EQF level 3, 4 and 5, which were our target group. 23 % of these students participated in the survey that done to analyze the conceptual and formative knowledge of the target groups in the first stage of the study. Certificates of achievement through the EDUMEC project were given to them at the end of the training.

A questionnaire including 23 questions was prepared to evaluate the participants’ opinions about the adequacy, quality, efficiency, understandability, accessibility, and benefits of the pilot training.

The evaluation criteria and the results for three different experiment sets are shown in **Table 5** (values are expressed as percentages of users responding). The pilot training received positive approval from around 65% of the participants, showing that the mechatronics field is very difficult to study for beginners.

**Table 5.** The results in percentage for three different experiment sets

	1. Disagree	2.	3.	4.	5. Completely Agree
<b>The contents of the training correspond to the training goals</b>					
Process Control	6.45%	0.00%	0.00%	12.90%	80.65%
Robotic	16.67%	3.33%	0.00%	3.33%	76.67%
PLC and motion control	7.50%	2.50%	2.50%	10.00%	77.50%
<b>Exercises are adequate</b>					
Process Control	6.45%	3.23%	6.45%	16.13%	67.74%
Robotic	13.79%	6.90%	6.90%	6.90%	65.52%
PLC and motion control	7.50%	2.50%	12.50%	5.00%	72.50%
<b>E-test are adequate</b>					
Process Control	12.50%	6.25%	3.13%	9.38%	68.75%
Robotic	13.33%	3.33%	0.00%	13.33%	70.00%
PLC and motion control	5.26%	5.26%	2.63%	5.26%	81.58%
<b>I estimate the whole e-learning contents as excellent</b>					
Process Control	9.68%	3.23%	9.68%	25.81%	51.61%
Robotic	16.67%	0.00%	10.00%	20.00%	53.33%
PLC and motion control	12.50%	0.00%	12.50%	10.00%	65.00%

**Table 6.** Questionnaire Results for Learning Portal

	1. Disagree	2.	3.	4.	5. Completely Agree
Learning portal is well organised	7.89%	2.63%	10.53%	18.42%	60.53%
The learning time is close to the predicted learning time.	15.79%	0.00%	5.26%	13.16%	65.79%
I appreciate that I can learn anytime and from any location	7.89%	2.63%	5.26%	2.63%	81.58%
I think that gained knowledge will be useful in my future career.	15.79%	0.00%	2.63%	15.79%	65.79%
I would participate in the advanced training	21.05%	2.63%	5.26%	15.79%	55.26%
I have (or will) recommend the training to my friends.	15.79%	2.63%	7.89%	10.53%	63.16%
	Distance Learning	Educational Booklet	Free of Access	Experiments	Everything
Which aspects of training and materials did you like the most.	60.47%	11.63%	4.65%	9.30%	13.95%

Finally, in this project, the possibility of successfully completing experiments performed by remote control was proven (**Table 6**). The results demonstrate the success and quality of the EDUMEC Project educational materials, pilot training, and mechatronics remote laboratory infrastructure.

## CONCLUSIONS

Remote access to a laboratory in the field of mechatronics, which was previously limited in availability, has now been established through the EDUMEC project at Marmara University. Access to the EDUMEC laboratory is available globally, allowing users to conduct real-time mechatronics experiments. On the EDUMEC platform, a remote access laboratory and 50 different courses are made available in an asynchronous format.

The effectiveness of the designed education model was primarily tested through pilot training with a set of students. Certificates of achievement were given to the students who successfully completed their training. After the pilot phase of training, the platform was opened through the EDUMEC webpage to offer asynchronous education free of charge for five years in the interest of ensuring the project's continuity. Hence, the project has accomplished its goals successfully.

At the beginning of the project, the efficiency of the system is only questionnaire questioned. The system will be updated with this questionnaire during the sustainability phase of the project. In addition, after the system has been applied for at least 2 years, feedback will be received from course trainees and employers.

Practical training in areas that require expensive equipment such as mechatronics can be performed using remote-access devices as an effective solution to provide this training. While EDUMEC offered users an option to take 50 theoretical courses in the field of mechatronics at EQF levels 3, 4, 5, and 6, they also had opportunities to

apply some of the learned skills such as robot control, process modeling, controller design, and PLC programming, in real time.

The EDUMEC project represented a successful example of a project in this area. Future work in improving the EDUMEC project in cooperation with the Turkey Ministry of Education will aim to expand the project to reach more institutions and people.

## REFERENCES

- Basso, M., & Bagni, G. (2004). Artist: A Real-Time Interactive Simulink-Based Telelab. *Proc. IEEE International Symposium on Computer-Aided Control System Design*, pp. 196–201. <https://doi.org/10.1109/CACSD.2004.1393875>
- Bliesener, M., Weber, C., Kling, K., Karras, U., & Zitzmann, D. (2007). *Festo Robotino Manual*. Denkendorf, Germany: Festo Didactic GmbH & Co. KG.
- Casini, M., Prattichizzo, D., & Vicino, A. (2004). The automatic control telelab—a web-based technology for distance learning. *IEEE Control System Magazine*, 24(3), 36–44. <https://doi.org/10.1109/MCS.2004.1299531>
- Castellanos, A. R. S., Hernandez, L., Santana, I., & Rubio, E. (2005). Platform for Distance Development of Complex Automatic Control Strategies Using Matlab. *International Journal of Engineering Education*, 21(5), 790–797.
- Corradini, M. L., Ippoliti, G., Leo, T., & Longhi, S. (2001). An Internet Based Laboratory for Control Education. In: *Proc. IEEE Conference on Decision and Control*, pp. 2833–2838. <https://doi.org/10.1109/CDC.2001.980703>
- EUROSTAT, Education and Training, Statistical Data. (2013, March 19). Retrieved from <http://epp.eurostat.ec.europa.eu/portal/page/portal/education/data/database>
- Fernandez, G. C., Borrego, R. C., Merino, P. P., Lopez, M. A. S. C., Ruiz, E. S., Gil, M. C., & Perez, F. M. (2015). Mechatronics and Robotics as Motivational Tools in Remote Laboratories. *IEEE Global Engineering Education Conference*, pp. 118–123. <https://doi.org/10.1109/EDUCON.2015.7095960>
- Ferreira, J. M., & Müller, D. (2004). The MARVEL EU project: A Social Constructivist Approach to Remote Experimentation. *1st Remote Engineering and Virtual Instrumentation International Symposium, Villach, Austria*.
- Gadzhanov, S. D., Nafalski, A., & Nedic, Z. (2014). LabVIEW Based Remote Laboratory for Advanced Motion Control. *11th International Conference on Remote Engineering and Virtual Instrumentation*, pp. 129–136. <https://doi.org/10.1109/REV.2014.6784237>
- Habraken, J. (2008). *Reference Architecture for e-Learning Solutions* (Master Thesis). Open University, Faculty of Computer Science.
- Hercog, D., Gergic, B., Uran, S., & Jezernik, K. (2007). A DSP-Based Remote Control Laboratory. *IEEE Transactions on Industrial Electronics*, 54(6), 3057–3068. <https://doi.org/10.1109/TIE.2007.907009>
- Ko, C. C., Chen, B. M., Chen, J. P., Zhang, J., & Tan, K. C. (2005). A Web-Based Laboratory on Control of a Two-Degrees-Of-Freedom Helicopter. *International Journal of Engineering Education*, 21(6) 1017–1030.
- Macancela, A. H. I., & Canizares, C. M. P. (2014). *Construccion de Una Platadorma de Instrumentacion Virtual Sobre Labview* (Master Thesis). Universidad Politecnica Salesiana Sede Cuenca.
- Oltean, S. E., Dulău, M., & Puskas, R. (2010). Position Control of Robotino Mobile Robot Using Fuzzy Logic. *Automation Quality and Testing Robotics (AQTR), IEEE International Conference on*, Volume: 1. <https://doi.org/10.1109/AQTR.2010.5520855>
- Rodriguez, F., Castilla, M. D. M., Sanchez, J. A., Pawlowski, A., & Moreno, J. C. (2015). Architecture to Develop Semi-Virtual Industrial Laboratories for the Interactive Learning of Process Automation. *Computer Application Engineering Education*, 24(3), 335–346. <https://doi.org/10.1002/cae.21709>
- Rojko A., Hercog D. & Jezernik K. (2011). E-Training in Mechatronics Using Innovative Remote Laboratory. *Elsevier Mathematics and Computers in Simulation*, 82, 508–516. <https://doi.org/10.1016/j.matcom.2010.10.017>
- Salzmann, C., Gillet, D., & Huguenin, P. (2000). Introduction to Real-Time Control Using Labview With An Application To Distance Learning. *International Journal of Engineering Education*, 16(3), 255–272.
- Sanchez, J., Dormido, S., Pastor, R., & Morilla, F. (2004). A Java/Matlab-Based Environment for Remote Control System Laboratories: Illustrated with an Inverted Pendulum. *IEEE Transactions on Education*, 47(3), 321–329. <https://doi.org/10.1109/TE.2004.825525>
- Shetty, D., Kondo, J., Campana, C., & Kolk, R.A. (2002). Real-Time Mechatronic Design Process for Research and Education. *Proceedings ASEE Annual Conference*.
- Tan, K. K., Lee, T. H., & Leu, F. M. (2000). Development of a Distant Laboratory Using Labview. *International Journal of Engineering Education*, 16(3), 273–282.

Valera, A., Diez, J. L., Valles, M., & Albertos, P. (2005). Virtual and Remote Control Laboratory Development. *IEEE Control System Magazine*, 25(1), 35–39. <https://doi.org/10.1109/MCS.2005.1388798>

Welp, E. G., Labenda, P., & Jansen, S. (2006). Teaching Theory and Practice in Mechatronics Engineering. *International Design Conference - Design Dubrovnik - Croatia*.

Xu, C., Ming, A., Kanamori, C., Aoyama, H., Li, H., Xu, L., ... Wong, C.-C. (2013). Internet-Based Crossover Robot Remote Control Competition among Asian Countries. *Elsevier Mechatronics*, 23(8), 933–941. <https://doi.org/10.1016/j.mechatronics.2013.06.003>

## APPENDIX

### List of Courses

English	Turkish	Czech	Slovenian	French
Modelling and Simulation of Mechatronic Systems using MATLAB Simulink			Modeliranje in simulacije mehatronskih sistemov z uporabo MATLAB-Simulink	
Digital Electronic	Sayısal Elektronik	Digitální elektronika	Digitálne elektronické	Digital Électronique
Closed -loop Control of Mechatronic Systems	Mekatronik sistemlerin Kapalı Devre Kontrolü			
Modeling Multiphysics Systems by Bond Graphs		Modelování Multifyzikálních Systémů Pomocí Bond Grafů		
Electrical Circuits	Elektrik Devreleri	Elektrické Obvody	Električna vezja	Circuits électrique
Real Time System		Systém Reálného času		
Introduction to Computer Vision				
Computer Vision / image Processing / Image Analysis				Introduction au Cours de Traitement d'Images
Introduction to Robotic Vision				Introduction à la Vision pour la Robotique
Introduction to Mechatronics	Mekatronik sistemlere Giriş	Servomotor v mechatronice	Uvod v mehatroniko	Introduction à la mécatronique
Mechatronic Devices	Mekatronik Cihazlar	Mechatronická zařízení	Mehatronske naprave	Appareils mécatroniques
Servomotor in Mechatronics			Servomotor v mehatroniki	
Artificial Intelligence	Yapay Zekâ		Umetna Inteligenca	Intelligence artificielle
Introduction to Process Control and Sensors	Proses Kontrolre Giriş ve Algılayıcılar			
Process automation MPS® PA Compact Workstation Manual	MPS® PA Proses Kontrol Eğitim Seti			
Robotics	Robot Bilim	Robotika	robotické	Robotique
Basic Experiments for ROBOTINO	ROBOTINO Temel Deneyler			

<http://www.ejmste.com>

# The Impact of Adopting Web 2.0-Based E-Book on Student Learning Skills

Hatim Ibrahim <sup>1\*</sup>, Abdullah Saad H Alqahtani <sup>2</sup>

<sup>1</sup> Educational Technology Department, Faculty of Specific Education, South Valley University, EGYPT

<sup>2</sup> Educational Technology Department, College of Education, Imam Abdulrahman Bin Faisal University, SAUDI ARABIA

Received 8 October 2017 • Revised 27 February 2018 • Accepted 5 April 2018

## ABSTRACT

The present study aims to design an e-book based on Web 2.0 applications: Wiki editors, Video casting and Rich Site Summary (RSS). It identifies the criteria for the proposed e-book and its impact on developing the skills of designing and utilizing Cloud Data. The sample consisted of (60) students divided into two groups: the control group (25) and the experimental group (25), and (10) students for pilot study. The results identified the principles for designing an e-book based on Web 2.0 applications. There were statistically significant differences at the level of (0.05) between the mean scores of the participants in the pre- and post-test for the skill performance observation card. There were statistically significant differences at (0.05) between the mean scores of the participants in the pre- and post-cognitive skills test. The results also indicated that the e-book based on Web 2.0 applications effectively achieved more than (1.2%) gain ratio.

**Keywords:** e-learning, web 2.0 applications, e-book, cloud data warehouse

## INTRODUCTION

In the light of the significant developments in the e-learning field, it has become a necessity to furnish schools with techniques and device required for applying the e-school system. As such, developing electronic educational sources such as e-books, e-laboratories and e-library required in various educational fields. Mazen (2009) states that e-learning is also considered an adequate and modern educational method to share the required information in the shortest time possible with less efforts and optimum benefit. According to Al-Dahsh (2007), the goals of e-learning have to be achieved throughout the educational process. Such goals include the provision of a rich educational environment that serves the educational process as well as modeling of education in a standard form such as the optimum utilization of the multimedia techniques and the model question banks. This is in addition to mainstreaming technological innovations in all educational institutions and the preparation of a generation of teachers and students capable of dealing with such technological innovations.

## THEORETICAL FRAMEWORK

The idea of e-book introduced in the early 1990s by Bob Stein, who compared reading through the computer screen and reading from a paper book, concluding that reading from an electronic device is better than reading from a paper book. E-Book is a cognitive tool that contains interactive learning modes based on the senses of hearing and seeing and uploaded on a site to be available to the largest number of learners. It allows the instructors and learners to store their work and enhance it with multimedia, besides the possibility of updating the content (Abu Shawish, 2013).

The e-content is managed through the Learning Content Management System (LCMS) known as MOODLE after being redeveloped to suit the nature of the educational system in general (Shimi, 2013). It helps provide flexible curriculum in line with the latest curriculum at the international level, it is a method of teaching technology and self-education, it contributes to improving the quality of teaching and learning through providing pictures, movies



### **Contribution of this paper to the literature**

- E-learning has become a necessity, due to the recent developments of communication and information technology. Educational institutions are concerned with introducing new types of scientific content in the form of independent learning objects, and also in employing the latest specialized software in the production and development of such content, while taking global standards into consideration.
- The present study is based on producing the proposed e-book through innovative tools, techniques and web 2.0 tools.
- There is a scarcity in the studies that tackled the severe deficiency in the skills of utilizing Cloud Data Warehouse among university students in particular.

and audio recordings and it is an interesting way to attract student by replacing the traditional approaches of memorization and indoctrination. Moreover, e-book characterized by its storage capacity and rapid retrieval of information, besides mainstreaming the use of computers in the information centers and the private sector as well as on-line retrieval of information. It also provides full interaction with students through images and animation in order to increase their ability to understand and analyze as well as the provision of simulation-based software similar to experience without exposing students to the danger of direct communication with such experience.

The forms of e-book vary in terms of design, content and treatment of the educational material, such as text e-books, picture text e-books, and multimedia e-books. These types include a set of digital systems and tools, including digital images of scanned book pages, Compressed HTML Help (CHM) system, PDF, TXT and RTF system. It can be designed by Notepad, WordPad in Microsoft Windows and HTML. DjVu, on the other hand, opens by a Program added to the Internet browser. It is originally a type of files specified to the collection of scanned books images.

### **Criteria of Designing E-Books**

It is necessary to refer to a set of criteria related to the effective use of the above-mentioned tools in the design of the proposed e-book. These criteria include technical criteria of designing e-books, color, and image as well as the criteria of using of images and forms. This is in addition to the technical criteria of animations referred to by several studies, such as Batoush (2002), El-Khoury (2000), Sadiq (2001) and Ismail (2009). Such criteria include: Ease of access to and exit from e-books, ease of transition to the final test without passing through all units, the screen should contain tools that help have an easy control of the presentation of information and the display of the content alternatives, specified timing to display the question on the screen and balance within the screen design. In addition, focus must be on graphics, rather than text and more than one screen design for the e-book should be utilized while maintaining consistency between the screens. For the window, utilizing more than one window on the same page contributes to the good use of the page space, while the size of window displaying videos or animation must be adjusted to the size of the screen so as to achieve image clarity and lower storage.

The present study included several components utilized in the design of e-books. Within this context, Azmi (2008) and Al-Garf (2008) pointed out that e-courses consist of a set of media of different shapes such as graphics, texts, exercises, tests and records to save scores, and they may also contain animations, simulations, sounds and links connected with other sites. The most important components include: Course homepage, course tools, information about faculty members who use the course, announcements, discussion board, chatroom, information about the course, course content, homework drop box, tests and evaluation, grade book, course statistics, e-mail center, shared files, memo page, video conferencing, and control panel.

### **E-learning, Web 2.0 and Cloud Data Warehouses**

The emergence of the Internet as a major information phenomenon is a reality that imposed itself on various scientific and social fields, leading to a change in their characteristics, tools, interactions and effects. Education is no exception. The Internet has passed through several generations where the first phase called Web 1.0, followed by the second phase, called Web 2.0. It is distinguished by interactivity, since its applications enable visitors and users to participate and create content. The Web 2.0 is a term that describes the second generation of the evolution of Internet technologies that allow individuals to change or influence the content of the Web. The social networking is designed for multiple purposes such as facilitating relationships; it is a learning environment based on the Web 2.0 tools (Gardner, 2008). They are used in web-based learning methodologies to create rich and flexible learning environments and promote active learning among students. Teaching and learning approaches are diverse and thus provide an access to Web 2.0 tools that provide new models for the design of education. Such approaches will prepare the best citizens, employees and learners for a knowledge-based society since the idea of Web 2.0 is based on rendering the Internet a platform where everyone can write, interact, and participate.



Within this framework, Livingstone and Bulger (2015) identified Web 2.0 as a generation of Internet technology, which came out due to cumulative changes in terms of how to use and design the Internet. It does not mean technical update of software or hardware, but it changes the way of using the Internet. It is considered widespread social networks, which include a range of applications and participatory tools as well as services that provide learners with the opportunity to create e-learning materials, besides the personal learning environments which reflect the new version of the Web 2.0. It is concluded that Web 2.0 is a system works in an integrated manner with Web 1.0 and a modern technology used in designing interactive web pages. It can be defined as the technical development that spread around the world through the use of the Internet, advanced programs and integrated systems. It is characterized by ease of mobility and speed of implementation of orders; it also provides users with the opportunity of interaction and positive communication. Tim O'Rally, the first user of the term Web 2.0, indicates four key points, namely: Interaction, Social communication, Collective Contribution to Content Production and Immediate participation (Mabrouk, 2011).

The components of Web 2.0 includes social media, classification of Web 2.0 tools, comments and posts, sharing content and web pages. In the current study, Web 2.0 utilized as a major component in designing the material of experimental processing of the e-book because of its special features. Web 2.0 deals with the web as an integrated development platform away from any other technical elements and the site takes advantage of the network resources and characteristics, the same way the developer benefits from the system orders while programming. Web 2.0 characterized by creativity, intelligence and collective intelligence in utilizing, networking and development, which aims to promote and publish the content among members. In Web 2.0 sites, data, i.e. digital content, is the most important element, including method of content display, quality and processing by content production, recording, publishing, collecting or organization. Livingstone and Bulger (2015) indicated to the importance of using Web 2.0, especially in the field of education. Web 2.0 forms the basis of social networking systems that improve student results. It enhances student participation in college, academic performance, and interaction with faculty and management. It stimulates opportunities for students and faculty towards positive and creative learning process. It contributes to the exchange of experiences among educators and helps to keep the impact of learning. Student role developed to serve as the producer of the substantive content and evaluate themselves.

Furthermore, cloud computing is a Web 2.0 applications through which a large section of personal computer use converted to the cloud. The term of cloud computing was first utilized in the late 1960s, inspired by the cloud code, which was often utilized to represent the Internet in maps and graphs. In the educational process, cloud computing enables the user to access his files and applications without installing the software on his/ her device. It saves a lot of money required to buy the software and reduces cost through reducing the number of the required hardware and employees of hardware and software maintenance. The current infrastructure of cloud computing includes data centers capable of providing service to customers all over the world. By utilizing cloud computing service, learners can conduct online tests, easy access to tests, exercises, projects and feedback, easy communication between students and learners, utilize applications without download, access to stored files from any computer through the Internet and access to all programs at any time and from any place.

### **Utilizing Digital Data Warehouses**

With the serious developments in the field of education technology, digital revolution emerged and digital technology became the dominant element in various fields general and in education in particular. Digital technology characterized by proving a large and varied digital sources, many of which are related to the educational process, including: the Internet, e-mail, electronic journals, digital libraries, chat programs, e-books, etc. which solved many educational problems such as lack of research data, large number of students, shortage of teachers, weak communication methods between the teacher and students, and the difficulty of retaining and copying the scientific material easily and quickly with the possibility of converting it to various forms, while saving time, effort and cost of learning assignments and activities for student and teacher. Learning through digital sources is significant, because of developing self-learning skills by searching printed and non-printed educational resources, acquiring some skills such as observation accuracy and results analysis, developing innovative thinking skills, developing scientific thinking and problem solving skills and develop the skills to deal with multiple means of communication.

### **Literature Review**

Gewertz (2012) explains that e-learning and the internet are deemed a fertile land for the growth of a collaborative learning environment. They provide social aspects of collaborative learning through some available collaborative tools. It is based on the exchange of information among a group of learners who frame discussions

and reorganize materials or concepts to build new relations among each other through receiving feedbacks from their colleagues in the group.

Several studies, including Milman (2009), Al-Naeimi (2001), Al-Far and Shahin (2001), Al-Hadi (2001), Reynolds (2002), Artman (2003) and Ateya (2003) emphasized that e-learning environment is effective in educational technology owing to its numerous advantages: motivating students, helping them understand and attracting their attention, developing their metacognitive skills, achieving effective active learning, and developing tendencies towards technological innovations. Among the studies that asserted the impact of e-book on the cognitive and skill performance were Al-Hoseiny (2005) who ascertained the effectiveness of e-book in the cognitive performance in the Computer Maintenance Course and Mahmoud (2007) who emphasized the effectiveness of e-book in developing academic achievement and self-learning skills among female students teachers in the Educational Technology Course and their impression of the Course.

Shiratuddin, Gibb, and Hassan (2005) referred to the impact of e-book on student performance through increasing their academic achievement and the influence of electronic learning environments. Rowhani (2005) stated that visual components of the e-book contributed to increasing the quantity of educational content as well as the various activities that address all the senses of learners. Ismail (2013) further laid an emphasis on the significance of electronic usage in developing the cognitive aspect relating to dealing with computers and the motivation of achievement among the third-year preparatory students.

Although e-book has proved to be effective, it has not been tested with the utilization of Web 2.0 applications. According to Downes (2006), Web 2.0 for e-learning is launched in late 2005 by the Institute for Information Technology's E-learning Research Group affiliated to the National Research Council of Canada Moncton, New Brunswick, which developed globally known standards in educational units, blogs and wiki. Web 2.0 for e-learning defined as small units of information that are flexibly linked together, while utilizing separate but complementary tools via the web. They further depend on wiki, blogs and other social internet applications that support the formation of web-based learning communities. Web 2.0 techniques are based on a number of main interactive and communicative tools, the most important of which are Wikis, Blogs, Social Bookmark, and Social Networks. Virtual collaborative learning is also considered one of the most modern learning and training techniques and it is called E-Learning 2.0, which means learning through social networks that allow content editing and updating by inserting a comment, or uploading a file. Thus, everyone is allowed to read, write and share, according to Hassan (2008).

Ramal (2009) states that the database techniques significantly developed over ages from Hierarchique through Relationally to Oriented Object. On the other hand, databases changed from being storage and search databases to information warehouses that help the process of decision making. Thus, the existence of new information systems that deal with such data in terms of storage and restoration has become necessary to enhance planning and future vision.

Data-Warehouse is a database that includes an immense amount of data to support the decision-making process inside an institution. This type of database is characterized by the Star Schema which complies with the user's needed indicators and includes historic data derived and extracted from the continuously updated database used in the applications. Cloud Data Warehouse is subject oriented, integrated and nonvolatile. Databases are considered one of the modern techniques for storing and restoring data; the significance of such technique is expected to increase in the future to handle the organization of the great quantity of information relating to major projects. This refers to the existence of the Database Management DBMS (Systems), which is a set of ready applications that carry out all functions required from the Database (Sorour, 2003).

### **Statement of the Problem**

The skills of utilizing the Cloud Data Warehouse are weak among the students of the Computer Courses, in general, and the Database Courses, in particular. The problem was emphasized through the traditional teaching method, lack of interaction between instructors and students and a lack of material resources in educational institutions. This is in addition to the lack of sufficient Arabic books in the field, the short time dedicated to Computer courses, only one lecture per week, and student inability to master the skills of designing warehouses data. Through Exploratory Study, a cognitive test applied and an observation card on a group of 60 students enrolled in the Computer Applications Course to measure the cognitive aspect and skilled performance of the Cloud Data Warehouse-related skills. The results showed that: a) Computer knowledge and skills are weak by 70%; b) The Cloud Data Warehouse-related skills are weak by 90%; c) Students are unable to design the Cloud Data Warehouse-related skills in the laboratory due to time limitations and the lack of material resources.

On the other, there is a need to utilize Web 2.0 based e-books in developing the skills of designing and utilizing Cloud Data Warehouse, so that the role of learners can be both receiver and producer of information. Accordingly, the educational course will be more flexible and influential through discussions and new methods of delivering information such as Blogs, Wiki and social media, which provide learners with several skills and enable them to

develop themselves through ongoing communications among various learners. Such new methods will further result in creativity and innovation in developing the educational content.

In light of the previous studies, surveys and the experience of the researchers, it has been proved that there is a lack of the skills of designing and utilizing Cloud Data Warehouse among the students of University of Imam Abdul Rahman bin Faisal due to the adoption of traditional teaching methods. Therefore, taking into consideration the significance of the Web 2.0 based e-book, the present study attempts to design a Web 2.0 based e-book to develop the skills of designing and utilizing Cloud Data Warehouse among the students of University of Imam Abdul Rahman bin Faisal and to identify the impact of such proposed e-book in developing the cognitive and performance aspects of such skills.

### Questions

This problem can be solved through answering the following questions:

1. What are the cognitive skills necessary for designing and using Cloud Data Warehouse needed to be developed among the students of University of Imam Abdul Rahman bin Faisal?
2. What is the proposed vision for Web 2.0-based e-book for developing the skills of designing and utilizing Cloud Data Warehouse among the students of University of Imam Abdul Rahman bin Faisal?
3. What is the impact of Web 2.0-Based E-Book on the cognitive performance of the Skills of designing and utilizing Cloud Data Warehouse among the students of the college?
4. What is the impact of Web 2.0-Based E-Book on the skilled performance of the Skills of designing and utilizing Cloud Data Warehouse among the students of the college?

### Objectives

The present study aims to:

1. Develop a list of the basic skills necessary for designing and utilizing Cloud Data Warehouse needed to be developed among the students of University of Imam Abdul Rahman bin Faisal.
2. Design a Web 2.0-based e-book to develop skills necessary for designing and utilizing databases and identify the contents and objectives of such book.
3. Study the impact of Web 2.0-based e-book on developing the cognitive and skilled aspects of the skills necessary for designing and utilizing Cloud Data Warehouse among students of University of Imam Abdul Rahman bin Faisal.
4. Direct the attention of officials of institutions of higher education to the need to use electronic books in the educational process in order to develop and improve teaching methods using modern technology.

### Hypotheses

1. There was a significant difference between the mean scores of student in the cognitive test of the experimental and control groups, in favor of the experimental group, due to the impact of e-book based on Web 2.0 on developing the skills of utilizing data warehouse in post-measurement.
2. There was a significant difference between the mean scores of students in the skill performance observation card of the experimental and control groups, in favor of the experimental group, due to the impact of e-book based on Web 2.0 on developing the performative skills of utilizing data warehouse in post measurement.

### METHODOLOGY

The quasi-experimental approach utilized to verify the study hypotheses and measure the impact of e-book proposed to develop the skills necessary to design and utilize data warehouse through identifying the causality between the independent variable and the dependent one. The independent variable is a web 2.0-based e-book, while the dependent variables include the cognitive aspect of designing and utilizing Data Warehouse and the performance aspect of designing and utilizing Data Warehouse.

### Population and Sampling

*Population:* students enrolled in Computer Applications Course, College of Education, Imam Abdul Rahman bin Faisal University.

**Table 1.** The experimental design of variables

Item	Pre-application	Treatment	Post-application
Experimental group	Pre-information test	Web 2.0-based e-book	Cognitive performance test.
Control group			Skill performance observation card.

Sampling: the sample consisted of (60) students enrolled in Computer Applications course in 2016/2017, College of Education at the University of Imam Abdul Rahman bin Faisal. The participants were divided into two groups: the control group (25) and the experimental group (25), as well as (10) students for pilot study. Imam Abdulrahman Bin Faisal University opened established in 1975, Dammam, Saudi Arabia. It opened with two pioneering colleges, the College of Medicine and the College of Architecture. Almost four decades later this academic institution has grown into a leading research university with 21 colleges spread throughout the Eastern Province and a student population of over 45,000. It continues to grow and develop, continually assessing and improving its curricula and expanding its academic capabilities in all disciplines, while at the same time engaging the public in addressing environmental and community challenges.

## Method

The quasi-experimental approach utilized to measure the effectiveness of the proposed e-book in the development of designing and utilizing cloud data warehouses skills among students of Imam Abdul Rahman bin Faisal University. Two equal groups selected: The control group studied using the traditional method, and the experimental group studied using e-book based on Web 2.0. Skill performance observation card and cognitive performance test applied to the students of both groups in designing and utilizing cloud data warehouse pre- and post- teaching.

The experimental design adopted to address the problem of the present study in the formation of two groups: the control group and experimental group.

Pre-test applied to the students of the two groups, then Computer Applications Course taught to the students of the two groups as following:

- The control group: Consisted of (25) students who studied using the traditional method,
- The experimental group: Consisted of (25) students who studied using e-book based on Web 2.0.

Post-teaching, skill performance observation and cognitive performance test applied to the students of both groups. Addressing the problem of the research is indicated through the experimental design shown in **Table 1**.

## Limitations

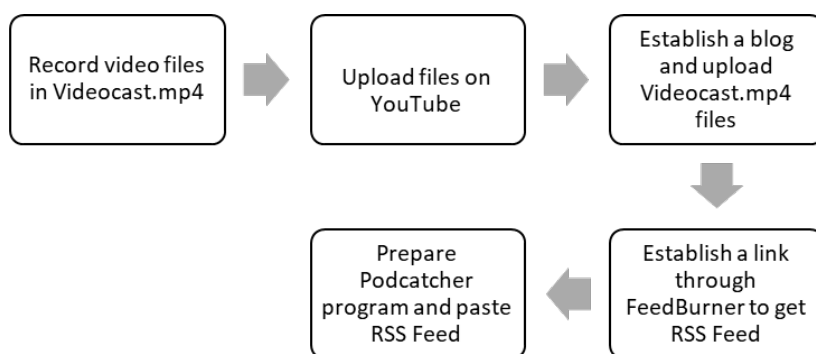
The scientific material is limited to the application of database using Microsoft Access studied by the students of University of Imam Abdul Rahman bin Faisal. Wikipedia and Facebook pages would be also used. For human and spatial limitations, the application of the research is limited to a sample of students of the University of Imam Abdul Rahman bin Faisal. Time limitations is the Academic year 2016\2017.

## Tools

1. A questionnaire to identify the skills required to design and utilize data warehouse (prepared by the two researchers).
2. An electronic performance test (prepared by both researchers).
3. A skill performance observation card (prepared by both researchers).

## Terminology

*E-book*: It is defined by Azmi and Al-Mradni (2010) as digital content available on the web consisting of a series of interactive, highly interactive pages, containing interesting multimedia elements and tools to interact with its content and structure. Mohammed (2008) sees it as a digital information medium produced by integrating the textual content of the book on one side and the applications of the digital environment on the other. According to Amin (2007), e-book is defined as "a technique for displaying printed or unprinted content in electronic form on the computer screen, depending on a variety of learning sources associated with the content; it can be browsed using desktop computers to provide the learner with the advantages of the electronic environment". It is also defined as a book or booklet in the form of electronic digital technology consisting of sequentially organized pages when connected to the network. It enables learners to communicate through the Web 2.0 applications and develop their cognitive and performance skills.



**Figure 1.** Steps of designing Video Casting tool

*Web 2.0 Tools:* Downes (2005) defines them as “the tools that enable learners to engage in an environment consisting of a network of people, services and resources.” It is procedurally defined as: the tools that enable students to interact and communicate with their peers in terms of educational material and performance skills in order to improve their skilled performance. These tools are: Participatory Web Editors, Visual Blogging, Newsletters, and Social media.

*Data Warehouses:* Abdullah (2009) defines it as “a set of permanent historical data that help make administrative decisions,” and contain huge amounts of data from different sources, or from several different data. It can be procedurally defined as a relational database designed to query and analyze to give better results in decision making. It is a type of database that contains a large amount of data intended to help the decision-making process within the organization.

### Procedures

The study proceeds through two major steps: 1) preparing for the experiment by reviewing the previous studies pertaining to e-books, developing practical skills utilizing Web 2.0 technology and data warehouses as well as preparing experimental processing tools; 2) preparing the e-book. The educational design models related to the design of online educational programs reviewed in Al-Hadi (2005). The process of preparing the e-book conducted through five main stages, including analysis, design, production, implementation, and evaluation.

### Analysis

The process of building the e-book begins with analysis including: a) analysis of learner characteristics, i.e. students of the College of Education who have previously studied Computer and able to use the Internet, e-mail, file download and chats; b) Analysis of Web 2.0 tools environment, three tools designed within the e-book environment, including Wiki, Video Casting and RSS. The Wiki tool is designed to provide students with a theoretical background about digital data warehouse, since students have no access to this information because there is no manual to guide them. The content of the tool includes the concept, objectives, principles, stages and modern strategies of teaching digital databases.

The Video Casting tool is designed to present a range of teaching skills (correct and wrong) to students in order to exchange views and establish new knowledge about teaching practices. It helps to achieve the required performance level during designing and utilizing digital data warehouse. The tool contains skill performance of students recorded by a digital camera. Because of skills multiplicity, the lecture is divided to sections recorded separately to be easily uploaded on the internet. The steps of designing the tool can be summarized in **Figure 1**.

The RSS tool is designed to link between Wiki and Video Casting tools to notify students and teachers about news, comments and video cast posts on the e-book environment. It contains news brief, i.e. title, description and date. RSS tool is added to the e-book environment, news reader software installed on the computer, RSS link is clicked and the page title is pasted in News Reader. For in class education, mini-teaching laboratory in the College of Education is equipped with (30) computers connected to the Internet, whiteboard and data show. For outside class education (at home), learning happens through the e-book where lectures prepared in the form of multimedia files (video - audio - pictures) and lecture repetition is available. The e-book aims to develop knowledge, skills and trends related to the design and use of data warehouses among students of the College of Education. For achieving the purpose of e-book, the content is set according to course description, books, references and scientific journals interested in this field.

## *Design*

Designing the e-book begins with organizing the e-book educational objectives by describing the learner behavior, the course and each educational unit in the form of statements. A flow map of the course developed for organizing and presenting the content. The course content organized in five modules, taking into account the logical sequence. A set of educational tasks and activities related to digital warehouse of each unit have been prepared, such as using search engines and websites to complete learning tasks such as photo collection, writing a report, etc., participating in panel discussions and communicate with colleagues through classroom discussions, sending and receiving emails and uploading files, generating images linked to cloud warehouse and presentations and presenting tasks through the forum of the e-book.

The e-book is presented through utilizing several strategies depending on integration between traditional classroom education and e-learning to achieve the objectives of the e-book. So, these strategies can be integrated according to the educational situation and the characteristics of the learners through the options provided by the e-book. It includes discussion, brainstorming, e-learning participation and e-learning projects. These strategies were chosen to allow students to express their views and encourage participation. For the design of teaching aids and learning resources, explanation depends on video and audio files and images contained in the e-book. Data projector and computers utilized in the computer lab to present activities, participatory tasks and answers of question bank. The e-book adopted many means, including pictures, drawings, recordings, video files, e-books and references and websites to teach science.

Interaction happens through student participation as available in the e-book, including synchronous or asynchronous interaction through e-mail. It takes place through the discussion of assignments and tasks in the lecture. Moreover, group learning mode utilized through a weekly lecture inside the class. Outside the lecture, individual learning mode based on e-book is adopted, allowing students and researchers to interact and talk about the design and use of digital Cloud Data Warehouse. Evaluation is conducted through three tools: 1) pre-evaluation through implementing pre-research tools and units pre-tests. 2) Formative evaluation through feedback during the study of the e-book and at the end of each unit. 3) Final evaluation through implementing post-research tools, student achievements in assignments and tasks and post-tests for each unit and the general test of the electronic book.

## *Production*

The e-book has been submitted to a group of reviewers to state their reviews and evaluate its validity and they declared the validity of implementing the e-book. Accordingly, the e-book teaching plan has been developed as a guide for the student to help them understanding the order of the course. The plan includes the general objective of the course, the objectives of the educational unit, the topics it contains, the educational activities, the method of implementation and the schedule of studying the course.

## *Implementation*

This phase begun with pilot experiment, to ensure that the e-book is free of spelling or technical errors or any design problems. It was tested on (10) students at the College of Education. The necessary amendment was made in the light of the results of the pilot experiment. Then, the proposed e-book is implemented and post-research tools applied.

## *Evaluation*

Evaluation of student learning of the course and measuring its effectiveness depending on student performances during the e-book study, such as participation, interaction, the use of e-mail, participation in the chat room and expressing opinion. In addition to products represented in completing the required tasks such as the publication of pictures or video or audio recording and performing electronic tests for each educational unit. Final test performance of educational knowledge associated with the skills of designing digital data warehouse, note card of design and use skills and performance testing.

To identify the cognitive skills required to design and utilize data warehouse and to be developed among students of the College of Education at Imam Abdul Rahman bin Faisal University, the pieces of literature related to the criteria of designing and utilizing data warehouse, reviewed. The skill list, in its initial form, submitted to reviewers specialized in education technology and techniques. According to their opinions, a final list of skills is developed, as shown in [Table 2](#).



**Table 2.** Skills of designing and utilizing data warehouses

Skills of designing and utilizing data warehouse	Sub-Skills	Relative weight
Designing and utilizing tables in the database	4	11%
Designing a database by Microsoft Access software	4	37%
Linking between tables in the database	4	18.5%
Designing and utilizing queries	4	7.5%
Designing and utilizing models	4	13%
Designing and utilizing reports	4	13%
Total	24	100%

**Table 3.** Agreement percentage on observation card indicators

student	1	2	3	4	5	6	7	8	9	10	Reliability mean
Agreement rate	84.5%	82.2%	88.7%	84.6%	80.6%	83.1%	88.3%	87.9%	82.5%	86.7%	84.9%

**Table 2** shows that the skill of ‘Designing a database by Microsoft Access software’ obtained the first rank of importance followed by the skill of ‘linking between tables in the database’ which got the second rank. The skills of ‘designing and utilizing models’ and ‘designing and utilizing reports’ had the same relative weight. Finally, the skill of ‘designing and utilizing queries’ obtained the lowest relative weight.

### Tool Validity and Consistency

The initial form of the questionnaire submitted to a set of examiners to check its validity in terms of items comprehensiveness and appropriateness to identify the skills required for designing and utilizing data warehouse in Computer Course. The author met the examiners during and after checking the questionnaire to discuss any questions that may be raised and their views concerning:

- Appropriateness of the item for measuring the targeted skill.
- Validity of items phrasing.
- Clarity of the questionnaire instructions.
- Adding or deleting any items.

The examiners agreed on the comprehensiveness and appropriateness of the questionnaire to identify the skills required for designing and utilizing data warehouse in Computer Course.

Consistency of the questionnaire items calculated by the correlation coefficient between each score of the questionnaire item and the total score of the questionnaire items for the scores of the pilot sample students. Correlation coefficients obtained in the closed period [0.53- 0.95]. Consequently, correlation coefficients were statistically significant at 0.01 indicating the consistency of the questionnaire items.

The skill performance observation card designed to measure the sample performance level of designing and utilizing data warehousing skills. Observation card paragraphs edited in the form of specific and clear procedural phrases, as each phrase describes one performance pattern. The observation card includes the same dimensions of designing and utilizing data warehouse skills of the sample, **Table 1** where the total number of sub-skills is (24). The observation card instructions edited in precise and clear form clarifying its objective, nature and how to record the observation. For observation card reliability, it submitted to reviewers and the necessary amendments conducted according to their views and suggestions. Observers agreement method utilized to calculate the observation card reliability. With a staff member at the College of Education, the card applied to a sample of (10) students enrolled in the College of Education for the academic year 2016/2017. The agreement rate calculated through Cooper equation:

$$Agreement\ rate = \frac{agreed\ times}{agreed\ times + disagreed\ times} \times 100$$

**Table 3** shows agreement percentage.

Cooper identified consistency level in terms of agreement percentage, as follows: Less than (70%) low card consistency and (85%) high card consistency. **Table 2** shows that the mean agreement rate is (84.9%), denoting high consistency of the card utilized to measure the level of student performance (Khtab, 2000). Four cells allocated for each sub-skill to represent the quantified performance score as follows: (3) scores for high skill performance, 2 scores for intermediate performance, one degree for lower performance and zero if the skill is not performed. The highest score for each card is (72), intermediate score (36) and (24) the lowest score.

**Table 4.** Test specifications for the skills of designing and utilizing data warehouses

Learning levels dimensions	Remembering	Understanding	Analyzing	Applying	Evaluating	Creating	Total	Relative weight
Databases concepts and terminology	2	2	-	2	-	1	7	20.8%
Cloud databases	1	-	-	2	1	-	4	29.2%
Data warehouse management	-	1	-	2	-	-	3	25%
Data warehouse design technology	-	2	-	-	1	1	4	12.5%
Databases warehouses use evaluation	1	-	1	-	-	-	2	12.5%
Total	4	5	1	6	2	2	20	100%
Relative weight	16.7%	18.7%	18.7%	16.7%	12.5%	16.7%	100%	

### Cognitive Performance E-Test

Cognitive performance e-test designed to measure the cognitive skills of the sample pertaining to the skills of designing and utilizing data warehouse. The dimensions of the test represent the units contained in the databases course for the sample. The test items composed of multiple choice pattern including (20) items distributed to measure different cognitive levels. Correct answer choice phrases not less than four including one correct answer. According to behavioral goals, items have diverse levels and comply with the test specifications of Bloom Taxonomy.

**Table 4** shows that the learning dimension of 'Cloud databases' obtained the first rank of importance followed by 'Data warehouse management' which got the second rank. While 'databases concepts and terminology' had the third rank, 'data warehouse design technology' and 'databases warehouses use evaluation' obtained the lowest relative weight. It also indicates that the relative weight percentage for 'understanding' and 'analysis' of the learning dimensions obtained the first rank, followed by 'remembering' and 'applying' which obtained the second rank. It helps determine the number and specifications of questions related to each learning level dimension in the test.

Test instructions are clear, answer sheet as well as test correction key prepared. The test submitted to reviewers to ensure its scientific and linguistic validity as well as suitability to the measured level of knowledge. The test items modified and the final test includes (20) items. Pilot study for the test conducted to a sample consisted of 10 students enrolled in the College of Education in the academic year 2016/2017, to calculate:

1. Test consistency coefficient using Cronbach equation and applying the test one time, it equals (.76).
2. Test time by the following equation:

$$\text{Test time} = \frac{\text{time taken by the first student} + \text{time taken by the last student}}{2}$$

By applying the equation, the test time is (30 minutes), acceptable time to perform the test.

3. Simple and distinguished items coefficient (Al-Bahi, 1978), where items obtained suitable simple and distinguished coefficient.
4. Ensure clarity of the test instructions, which were clear to the students and written in an easy accurate language. So that, the test has a high level of validity and reliability to be applied.

Test score identified by giving one point for choosing the correct answer and zero for choosing the wrong answer, and thus, the highest score of the test is (20). The final form of the test applied as it became on the appropriate level of reliability and consistency. SPSS software utilized to schedule and process the results of the application of the program.

## RESULTS AND DISCUSSION

The cognitive skill results for experimental and control groups are compared to verify the validity of the first hypothesis, stating that There was a significant difference between the mean scores of student in the cognitive test of the experimental and control groups, in favor of the experimental group due to the impact of e-book based on Web 2.0 on developing the skills of utilizing data warehouse in post-measurement. The experimental group students exposed to the e-book based on Web 2.0 compared to control group students exposed to the traditional training program, with regard to the cognitive skills of designing and utilizing Cloud Data Warehouse.

**Table 5.** Experimental and control groups means, standard deviations and T-test

Group	Application	No.	Mean	Standard deviation	Freedom degree	T value	Significance Level
Control	Pre- application	25	18.11	4.05	50	9.98	≤ 0.05
	Post- application		25.39	5.90			
Experimental	Pre- application	25	28.43	4.32	50	9.98	≤ 0.05
	Remote application		36.25	3.45			

**Table 6.** Means, standard deviations and T significance in pre- and post-application

Group	Application	No.	Mean	Standard Deviation	Freedom Degree	T value	Significance level
Control	Pre-application	36	8.43	2.72	24	42.08	≤ 0.05
	Post-application	36	23.61	3.45			
Experimental	Pre-application	36	10.14	1.46	24	47.00	≤ 0.05
	Post-application	36	36.25	2.32			

T-Test for two independent samples utilized to identify the differences between the cognitive performance level for the control and the experimental groups students in post-application of the cognitive test in the performative side.

**Table 5** shows that there were significant differences at the level (0.05) between the mean scores of experimental group students exposed to the e-book based on Web 2.0 compared to control group students exposed to the traditional training program, for the experimental group. Accordingly, the first hypothesis accepted, which means that there is a significant difference between the mean scores of student in the cognitive test of the experimental and control groups, in favor of the experimental group due to the impact of e-book based on Web 2.0 on developing the skills of utilizing data warehouse in post-measurement.

### The E-Book Impact Size on Performance

The impact size can be defined as a quantitative value indicating the relationship degree between study variables within a pre-defined population, regardless of the statistical method utilized to express that impact. It means to express the relationship between the independent and dependent variables by obtaining the size of the dependent variable variation which can be explained by the independent variable. The value of the impact size utilizing Eta-Squared of the cognitive skill is (0.168), a big and appropriate value exceeding the significant value of educational signification (15.0) for the statistical results in educational, psychological research. Accordingly, the e-book based on Web 2.0 has a significant educational impact on the experimental group students.

T-Test for paired samples utilized to verify the second hypothesis, stating that there is a significant difference between the mean scores of students in the skill performance observation card of the experimental and control groups in favor of the experimental group due to the impact of e-book based on Web 2.0 on developing the skills of utilizing data warehouse in post-measurement.

**Table 6** shows that there were significant difference at the level (0.05) between the mean scores of the control group students who utilized traditional Cloud Data Warehouses and the experimental group students in pre- and post-application of observation card of e-book Cloud Data Warehouses, for post-application. Accordingly, the second hypothesis is accepted. Black modified gain ratio utilized to measure the effectiveness of the integrated program of cognitive achievement to compare pre- and post-test mean of the experimental group, according to the following equation:

$$Black\ Modified\ Gain\ Ratio = \frac{Y-X}{S-X} + \frac{Y-X}{S}$$

where; Y is the mean scores of post-application, X the mean scores of pre-application and S the test final score.

**Table 7** shows that the impact of the e - book based on Web 2.0 is acceptable for the experimental group, where Black modified gain ratio (1.36), i.e. < (1.2) the effectiveness identified by Black. It confirms the effectiveness of the e-book on the skill of designing and utilizing Cloud Data Warehouse. For cognitive skills of designing and utilizing Cloud Data Warehouse, the experimental group students exposed to e-book in designing and utilizing Cloud Data Warehouses are better than the control group students exposed to the traditional training program. For performative skills of designing and utilizing Cloud Data Warehouse, the results indicate to the effectiveness of the experimental group.

**Table 7.** E-book impact on skills utilizing Black modified gain ratio

Group	pre-application mean score	Post-application mean score	Modified gain ratio	Significance Level
Experimental	10.14	36.25	1.36	$\leq 1.2$

## CONCLUSION

The e-book based on Web 2.0 in designing and utilizing Cloud Data Warehouses provides many advantages, such as improving the effectiveness and efficiency of training, flexibility and availability of multiple channels, combining the advantages of e-learning and traditional training. In addition, face-to-face communication increases student interaction as well as student-teacher interaction and student-content interaction through workshops and training on activities related to utilizing Cloud Data Warehouses and communication tools, such as e-mail and Facebook. Through the implementation of individual and collaborative activities, trainees are able to interact and be trained on multiple activities achieving a positive impact on their understanding through Web 2.0 participatory and interactive applications. Moreover, learning by e-book based on Web 2.0 contributed to solving the problem providing paper copies of the educational materials and presentations. In addition, e-book based on Web 2.0 attracts student attention for a longer period through appropriate various activities, interactive communication between the student and the e-book and providing students with the appropriate feedback as emphasized by the visual communication theory.

Cloud Data Warehouses, including workshops and training site contains presentations, training material, stable images and video clips that link between the student's memory and the presented material and attract his attention to the curriculum details. Thus, the training becomes more effective and applicable as indicated by Stimuli Summation Theory. Thus, e-book based on Web 2.0 in designing and utilizing Cloud Data Warehouse provides interactive multi - modal learning that includes more interaction with content, student and teacher through online communication tools provided by Web 2.0. These advantages are not available in traditional education carried out in the framework of specific learning hours.

## RECOMMENDATIONS

In the light of the research results, it is recommended to make use of the proposed principles and standards in the field of education through providing them to the planners of special educational Web 2.0 programs in public and university education. The proposed e-book based on other tools of Web 2.0 can be applied on other courses of pre-university and university education. It is important to provide a theoretical manual for training on utilizing Cloud Data Warehouse containing a theoretical background to help students performing digital computing practices. Adopting a unified Arab project in order to provide e-schoolbooks which include theoretical questions, images, video and slide show training programs. Attempt to characterize and prepare a curriculum contains educational and technological foundations of the e-book based on Web 2.0 depending on utilizing technology in education.

## SUGGESTIONS FOR FURTHER STUDIES

1. Applying e-learning within a traditional learning environment, i.e. not to demolish traditional learning, but utilizing both of them in a complementary manner, especially for young children education.
2. An Analytical study on Internet networks rehabilitation and providing the possible electronic means for schools and educational institutions.
3. A Study on e-learning in university work, especially for graduates focusing on their graduation projects.
4. Building a digital system specialized in e-learning for elementary stage as a first stage of application. The idea is to provide e-learning system equivalent to the subject given in elementary stages, enhanced by examples, explanations and realistic simulation based on full documentation (video, flash, audio files and examples) to be a permanent reference.

## REFERENCES

- Abdullah, H. (2008). *The impact of using web2 on the collaboration learning skills*. Education College of Umm Alqura University.
- Abdullah, A. (2009). *Data Warehouse*. Retrieved on 27/1/2018 from <https://goo.gl/3un3SY>

- Abu Shawish, A. A. (2013). *Proposal for the development of the skills of designing e-courses for technology education students* (MA Thesis). Al-Aqsa University, Gaza, College of Education, Islamic University of Palestine. Retrieved from <http://library.iugaza.edu.ps/thesis.aspx>
- Al-Bahi, F. (1978). *Statistical psychology and human mind measurement*. Egypt, Cairo: Dar El-Fkr Al-Arabi.
- Al-Dahsh, A. M. (2007). E-learning: ongoing development, training and techniques. *General Organization for Technical Education and Vocational Training*, (96), Riyadh.
- Al-Far, I., & Shahin, S. (2001). Electronic school: A new vision for a new generation. *Eighth Scientific Conference of the Egyptian Society for Educational Technology*, Electronic School, Girls College, Ain Shams University, p. 38-49.
- Al-Garf, S. R. (2008). Requirements of electronic curricula model activation in Saudi public education. *E-Learning first forum*. Saudi Arabia, Ministry of Education. Retrieved from <http://www.eqra.com.sa/Data/dt-0021.pdf>
- Al-Hadi, M. M. (2001). *Communication technology and information network*. Cairo: Academic Library.
- Al-Hadi, M. M. (2005). *E-Learning*. Cairo: Egyptian Lebanese House.
- Al-Hoseiny, A. M. (2005). *The use of e-book in university education and its impact on acquiring the skill of computer maintenance* (Unpublished MA thesis), Department of Educational Technology, College of Education, Ain Shams University.
- Al-Naeimi, N. M. (2001). The impact of multimedia software with internet access on the level of information among students with external and internal control sources and their achievement in the field of educational technology. *E-School, the 8<sup>th</sup> scientific conference of the Egyptian assembly for Education Technology*, the Faculty of Girls, Ain Shams University, 2001. Cairo: Alam Al-Kutb, 279-314.
- Amin, M. Z. (2007). E-Book and its impact on educational achievement for technology students with high and low self-management of knowledge. *College of Education Journal*, University of Beni-Suef, p. 9.
- Artman, E. M. (2003). *Motivation factors to overcome faculty resistance to integrating asynchronous online education in higher education business courses* (Doctoral Dissertation). San Francisco, CA: University of San Francisco.
- Ateya, M. (2003). *Products of education technology*. Cairo: Dar Al Kalima.
- Azmi, G. N. (2008). *E-Learning Technology* (First Ed.). Dar Al-Fikr Al-Arabi, Cairo. p. 85.
- Azmi, G. N., & Al-Mradni, M. M. (2010). The impact of interaction between various patterns of learning structural pillars within e-book in achievement and efficiency among graduate students at girls colleges. *College of Education Journal*, 16(3), p. 260. Helwan University.
- Batoush, K. (2002). E-Publishing and the inevitability of access to information at the Algerian University Library. *Journal of Libraries and Information*, 1(1).
- Downes, S. (2005). *E-learning 2.0*. Retrieved on March 3, 2007 from <http://www.downes.ca/post/31741>
- Downes, S. (2006). *E-learning 2.0, elearn MAGZINE Association of Computing Machinery*. Retrieved on Jan, 3, 2008 from <http://www.elearnmag.org>
- El-Khoury, Sh. H. (2000). E-publishing and the future of the printed word. *Arab Journal*.
- Gardner, J. (2008). *The Reliability of assessments and learning* (Second Ed.). Sage Chapter in Book/Report/Conference proceeding > Chapter, p. 243-263.
- Gewertz, C. (2012). *Test Designers Tap Students for Feedback*. ERIC Document reproduction Service No. (EJ1000124).
- Hassan, Y. A. (2008). *The impact of utilizing E-Learning 2.0 on cooperative education skills among students of Teachers College in Abha* (PhD Thesis). College of Education, University of Umm Al-Qura.
- Ismail, R. (2013). *The impact of utilizing e-book in developing the skills of dealing with the computer and motivation for achievement of students in the third grade independent and accredited preparatory schools* (Unpublished MA), College of Education, Department of Teaching Curriculum and Methods, Minia University.
- Ismail, Z. A.-G. (2009). *Electronic courses: design, production, dissemination, implementation and evaluation*. Egypt, Cairo: Alam El-Kutb.
- Khtab, M. A. (2000). *Measurement and Evaluation in psychological, educational and social sciences* (2<sup>nd</sup> Ed.). Egypt, Cairo: Anglo-Egyptian library.
- Livingstone, S., & Bulger, M. C. (2015) A global research agenda for children's rights in the digital age. *Journal of Children and Media*. <https://doi.org/10.1080/17482798.2014.961496>
- Mabrouk, I. M. (2011). *The impact of content presentation strategies in the integrated learning environment on developing the skills of developing e-learning resources and their use among students* (Unpublished PhD thesis), Department of Learning Technology, College of Education, Helwan University.

- Mahmoud, S. (2007). *The impact of e-book design variables on achievement and self-learning skills and impressions of students in the technology curriculum* (Unpublished MA thesis), Girls College, Ain Shams University.
- Mazen, H. (2009). *Information Technology and Electronic Media*. p. 80, Egypt: Sohag.
- Milman, D. (1999). Strategies for the design and delivery of blended learning courses. *Educational Technology*, 46(6).
- Mohamed, R. E. (2005). *The impact of a program based on integrated e-learning on the skills of designing the individual educational plan for special education teachers* (Unpublished PhD thesis), Faculty of Kindergarten, Alexandria University.
- Ramal, M. (2009). The role of database modern technology in constructing information society in the Arab World. Retrieved on 11/2/2018 from <https://goo.gl/94Kodi>
- Remal, M. (2009). *The role of technologies to build Arabic information society*. Retrieved from [http://www.arabcin.net/arabic/5nadweh/pivot\\_3/new\\_technique.htm](http://www.arabcin.net/arabic/5nadweh/pivot_3/new_technique.htm)
- Reynolds, D. (2002). Preparation of mathematics teachers: Lessons from review of literature on teachers' knowledge beliefs and teacher. *Education Journal of classroom interaction* 2, 3-15.
- Rowhani, S., & Sedig, S. (2005). E-book plus role of interactive informative visuals in exploration. *Journal of Computer in Mathematics and Science Teaching*.
- Sadeq, M. U. (2001). The E-book. *The 12th Arab Conference of the Arab Federation of Libraries and Information, entitled: Arab Libraries at the Beginning of the Third Millennium*, Sharjah, 5 - 8 November 2001.
- Shimi, S. A. N. (2013). Innovative concepts and visions to develop interactive e-content in Egypt. *Third Conference of e-learning and distance education*. Saudi Arabia, Riyadh, p. 1-23. Retrieved from <http://eli.elc.edu.sa/2013/>
- Shiratuddin, L., Gibb, F. M., & Hassan, Sh. (2002). *E-Book technology and its potential applications in distance education computer and information sciences Department*. University of Strath clyde, 26 Richmond Street.
- Sorour, A. S. (2003). *Management of modern databases*. p. 54. Riyadh: Dar Al-Mareekh for Publishing and Distribution.

**<http://www.ejmste.com>**



# Use of Tangible Materials and Computer in Mathematics Teaching: Opinions of School Principals

Sait Akbaşlı<sup>1\*</sup>, İlknur Yeşilce<sup>2</sup>

<sup>1</sup> Hacettepe University, Faculty of Educational Sciences, Ankara, TURKEY

<sup>2</sup> Aksaray University, Faculty of Science and Letters, Aksaray, TURKEY

Received 7 November 2017 • Revised 6 April 2018 • Accepted 10 April 2018

## ABSTRACT

School principals, who are responsible for all kinds of activities, should make necessary efforts in order to provide an effective learning environment. It is known that students usually have difficulties in visualizing abstract concepts in their minds and these difficulties are most often observed when teaching mathematics. Activating lessons for students by using tangible materials rather than abstract concepts will facilitate the teaching process considerably. The sample group of this study consisted of 184 school principals selected by the random sampling method from the school principals working in three provinces in the 2016-2017 academic year. All population lists of this study were accessed from the 2015-2019 Strategic Plans on the official website of Aksaray, Kahramanmaraş and Mersin Provincial Directorates for National Education. The data collection tool of the study was the scale developed by the researchers of this study. The collected data were analyzed in line with the sub-problems of this study. The school principals reported that tangible materials should always be used and computers should be frequently used in mathematics lessons. It was concluded that the school principals would always support the purchase of tangible materials and they would often provide support for the programs and equipment required for computer use.

**Keywords:** tangible teaching object, mathematics teaching, mathematics and computers, school principals

## INTRODUCTION

It can be said that taking advantage of the advancing technology with tangible materials and visuals in education activities is an important practice. Mathematics and mathematics teaching exist independently of the individuals whether created or discovered by mankind (Post, 1981). Galileo (1564-1642) stated that "the universe is always open for our observations, but it cannot be understood without knowing and comprehending its letters and language. The universe was written in the language of mathematics; its letters are triangles, circles, and other geometric figures. Without them, even a single word cannot be understood; it is like wandering in a dark labyrinth without them." As Galileo further stated, "Philosophy is written in this grand book, which stands continually open before our eyes (I say the 'Universe'), but cannot be understood without first learning to comprehend the language and know the characters as it is written. It is written in mathematical language, and its characters are triangles, circles, and other geometric figures, without which it is impossible to humanly understand a word; without this, one is wandering in a dark labyrinth." (As cited in Burt, 2003). As can be understood from the statement of Galileo, mathematics is included within the universe. In this regard, learning mathematics, which is found in everything in life, will be the same as learning life. As mathematics, which originates from the existing, has reached up to quite advanced levels in our age, it is believed that it has become difficult to understand. However, when we turn our heads, we can see that the language of the universe is probably the most easily understandable science. One of the biggest mistakes made in this education field and mathematics is providing this language without making sense of it by means of tangible data. In fact, the mathematics can be internalized more easily if the vital tangible counterparts of all information are known by the learners and these become meaningful whenever encountered.

#### Contribution of this paper to the literature

- There are a few studies conducted on the use of tangible materials in mathematics lessons within the context of Turkey, especially regarding the opinions of school principals.
- There are a few studies assessing the use of tangible materials and computer in lessons together within the context of Turkey and international context.
- The teachers with high seniority levels are reluctant to use tangible materials in mathematics lessons. In this regard, this paper can contribute to the literature and increase their use of tangible materials.
- The use of tangible materials in mathematics lessons is less, especially within the context of Turkey. The use of tangible materials can be increased due to the findings and recommendations of this study.

This is why many studies have been conducted and are being conducted in this field. The use of mathematics as required by our time and use of tangible materials for learning mathematics with its vital counterparts may be possible by means of computer-assisted education. Tangible materials within mathematics teaching are described as follows: Tangible materials include specifically designed tools (equipment) and real objects such as pictures and objects that materialize mathematical concepts (Van de Walle, 2007). Tangible materials are regarded as the objects that can be touched and moved (Hacıomeroglu & Apaydin, 2009). These materials make it easier for the students and learners to understand mathematical concepts more clearly and concretely (Moyer, 2001). It can be said that one of most significant outputs of these studies is "Movement for Increasing Opportunities and Improving Technology", or the FATİH project, carried out by the Ministry of National Education and Ministry of Transportation in November 2010. In fact, as can be understood from this project, a great deal of importance is placed on the use of computers in mathematics teaching in Turkey. In addition to this, the use of tangible materials during lessons is emphasized in the new mathematics teaching program implemented since 2005 and developed by the Ministry of National Education (MoNE) by adopting a constructivist teaching philosophy. Considering the vision of this mathematics teaching program, it is emphasized that the concepts in mathematics are abstract by nature, it is difficult for children to perceive these abstract concepts when their developmental characteristics are examined and it is necessary to support the teaching of mathematical concepts with tangible materials. Based on the fact that the students must be active participants in the mathematics teaching process, this program emphasizes that students will create their own thoughts from their interactions with the environment, tangible objects and their peers (Aydogdu Iskenderoglu, Turk, & Iskenderoglu, 2016; MoNE, 2013). In addition to this, in recent years, many studies have been conducted for determining the opinions of mathematics teachers on computer-assisted mathematics teaching (Fuson & Briars, 1990; Yenilmez & Karakus, 2007) and determining the opinions of mathematics teacher candidates on the use of teaching materials in mathematics teaching (Tooke, 2001; Unlu, 2017; Valverde, Bianchi, & Wolfe, 2002; Van de Walle, 2007) and determining the knowledge levels of mathematics teacher candidates for using tangible teaching objects (Tutak et al., 2012). In a declaration published by the American National Council of Teachers of Mathematics in September 1987, it was stated that the teachers could use computers as a tool in mathematics lessons when teaching concepts, developing tangible mathematical ideas from tangible experiences and teaching problem-solving processes (Aktumen, 2002; Daghan, Kibar, Akkoyunlu, & Atanur-Baskan, 2015; NIER, 1987).

Some studies have been conducted on the use of computer technologies in mathematics lessons and the following results have been revealed: (1) the lessons become more interesting and productive for teachers, (2) the attention and motivations of students are increased when lessons are supported with computers and tools are used, and (3) it has become easier to interact through the use of text, audio, video and graphic elements of technology (Adiguzel, Gurbulak, & Saricayir, 2011; Akdemir, 2009; Smith, Higgins, Wall, & Miller, 2005).

In terms of the teaching-learning process, school principals have emphasized that the process has become more enjoyable and the interests of teachers and students in lessons have increased. The school principals mentioned here and all through this article are described in the MoNE regulations as the school principals and deputy principals should provide the tasks for teachers (MoNE, 2013). In accordance with the Regulation on Secondary Education Institutions published by the MoNE in 2013, the duty of school principals is to provide the classroom, information technology classroom, laboratory, workshop and library with tools and equipment for teaching and training in line with health and safety requirements. In addition to this, they are to bring technological advancements to the school. They determine the requirements of the school and complete the necessary procedures to meet these requirements by purchasing, donation or in similar ways according to the budget. They notify the relevant departments about the requirements of training tools and equipment. Therefore, all possibilities are in the school principals' power. These data can be shown as a reason why the opinions of school principals on the use of tangible materials and computers in mathematics lessons are important. The studies conducted and previous experiences show that it will be impossible to successfully use technology without the support of school principals (Akinci, Kurtoglu, & Seferoglu, 2012; Dursun et al., 2013). The study conducted by Arikan, Aydogdu, Dogru, and Usak (2006) on computer-assisted education can be given as an example in this regard. In this study, it was seen

that the sample group learning with computers was more successful than the sample group learning using traditional methods and, therefore, their learning was more permanent.

It has also been revealed that the tangible materials used in mathematics lessons, have many benefits such as embodying the abstract mathematical concepts (Moyer, 2001), making it easier to understand mathematical concepts (Kennedy & Tipps, 1994) and allowing for conceptual learning (Dienes, 1967). However, in some of the studies conducted in Turkey, it has been revealed that the levels of teachers' use of materials in mathematical lessons are not high (Piskin, 2010; Toptas, Celik & Karaca, 2012). In fact, the teachers in Turkey, have suggested that our students can understand very abstract mathematical topics and they learn mathematics in a more enjoyable and permanent way due to the tangible materials. Despite these positive opinions, it was stated that teachers and students were not able to procure materials for a variety of reasons and, therefore, they could not use these materials (Akbayir, 2016).

In line with the results of the studies in the literature, the following information can be obtained: (1) mathematics includes abstract concepts, (2) the teachings are based entirely on these concepts and (3) there is an excessive increase in the amount of knowledge that must be given in lessons due to the ever-advancing science. Therefore, it has been concluded that the way the lessons are taught needs to be changed in order for information to be reproduced, to be understood and to be permanent. From the studies conducted so far, it is seen that this is possible by means of the use of tangible materials and computer-assisted education. However, the opinions and possibilities of school principals on issues such as how these auxiliary objects will be procured, how they will be used in learning environments and whether they are allowed or not are also important. Therefore, the opinions of school principals on issues such as the possibilities of mathematics lessons, teaching mathematics and how to answer the demands of teachers were referred to and the results obtained were shared in this study.

## RESEARCH QUESTIONS

The research questions of this study were:

- What is the level of school principals' opinions on the use of tangible materials and computers in mathematics lessons?'

In this regard, the sub-problems were:

- What are the opinions of school principals on providing tangible materials and computer-aided teaching in mathematics lessons?
- Are there any differences in the opinions of school principals according to their gender?
- Do the opinions of school principals differ according to the number of students in school?
- Do the opinions of school principals differ according to the number of mathematics teachers in school?
- Do the opinions of school principals differ according to the number of managers in school?

## METHOD

### Research Model

The research model of this study was a general screening model from quantitative research designs. In general, the whole population is analyzed or a sample group is chosen from this population in order to reach a general conclusion about the population consisting of a lot of elements, and the main purpose is to describe the current situation as it is (Balci, 2005; Karasar, 2014). This study is a descriptive screening study as it aims at explaining the current situation as it is without any manipulation.

### Population and Sample Group

The population of this study included the primary, secondary and high school principals working in Aksaray, Kahramanmaraş and Mersin provinces of Turkey. Considering the breadth of the population, it was determined that the selection of a sample group was necessary and, therefore, the sample group was selected by the random sampling technique. Simple random sampling technique was employed when selecting the sample group. In the simple random sampling technique, the sample group is selected randomly and objectively considering the possibility of being equal and independent for each unit (Balci, 2005; Buyukozturk, 2005). In this study, this principle was followed and the individuals to be included in the sample group were selected randomly. The study group consisted of 184 individuals randomly selected among the school principals working in these provinces in the 2016-2017 academic year. All population lists of this study were accessed from the 2015-2019 Strategic Plans on the official website of the Aksaray, Kahramanmaraş and Mersin Provincial Directorates for National Education.

Online forms were randomly sent to the school principals included in the sample group until the total number reached up to a level that reflected the whole population. The purpose here was to create a small sample and to reflect the diversity of individuals that could be a party to the problem studied in the sample at a maximum degree (Yildirim & Simsek, 2013). The participation in this study was based on the principle of volunteerism.

### Data Collection Tool

The scale used in this study consisted of two parts: The first part of the scale consisted of personal information and the second part consisted of 21 items about the opinions of school principals on the use of tangible materials and computers in mathematics lessons. The school principals in schools affiliated to the MoNE in Turkey were assigned according to the total number of students in primary, secondary and high schools as follows: (1) school principals for schools with 100-601 students, (2) school principals for schools with 601-1201 students, (3) school principals for schools with 1201-1501 students, (4) school principals for schools with 1501-2001 students and (5) school principals for schools with 2001 and more students (MoNE, 2014). The items in the second part were obtained as a result of the literature review and consisted of 36 items (18 positives, 18 negatives). After receiving the opinions of experts, the number of items decreased to 21 (18 positives, 3 negative items) as a total of 15 items was found to be inappropriate. The scale consisting of 21 items was changed into a 5-point Likert-type scale. These items were created in five degrees of participation as follows: (1) Always, (2) Often, (3) Sometimes, (4) Rarely and (5) Never. In order to interpret and compare the mean values in the analysis of sub-dimensions, a standard interval criterion was determined and the arithmetic average score interval coefficient was obtained with the following formula:  $(\text{highest score} - \text{lowest score}) / (\text{number of options}) = (5-1)/5 = .80$ . The boundary values were determined for the options such as Never, Rarely, Sometimes, Often and Always respectively as 1.00-1.80, 1.81-2.60, 2.61-3.40, 3.41-4.20 and 4.21-5 (Aydin, 2012). The scale used in this study provided the opinions of school principals on the use of tangible materials and computers in mathematics lessons in terms of sub-dimensions scores and total scores. The opinions of 3 academic members, 4 mathematics teachers with 5-12 years of experience and one assessment and measuring expert were taken in order to ensure the content validity of the measuring tool. The school principals were assessed according to the opinions they expressed. The item analysis, difficulty and discrimination indices of the data obtained from the scale were performed in SPSS software and KR-20 values were calculated. As a result of the pilot study, the total 27 questions in scale were reduced to 21 questions. In line with the data obtained from the school principals as a result of the assessment of the prepared scale, the reliability (KR-20) was found to be 0.86. This shows that the measuring tool is very reliable. As the total number obtained from the scale increases, the negative attitudes of individuals towards the measured structure increase. In other words, the high scores obtained from the scale show high negative attitudes. The highest and lowest scores that can be obtained from the scale are 105 and 21, respectively. When conducting the study, the personal information of the participants such as gender, seniority, educational institutions they work in and their educational levels were also requested in line with the aims of this study. The participants were informed and the aim of the study was explained during the implementation.

### Data Analysis

The obtained data were resolved under the sub-problems of this study. The data were analyzed using SPSS 22 (Statistical Package for Social Science) software. The items of scale were graded and the data set was reviewed for lost and extreme values before analyzing. No lost value was found in the dataset. During extreme data review, some data entries were corrected. In addition to this, the possible negative effects of some extreme values that can disrupt normality were removed by changing them to their closest values. The normality of the research data was analyzed using the Kolmogorov-Smirnov Test. The analyses were performed after ensuring that the distribution was normal. T-test (Independent - Samples T-Test) was used in order to test whether school principals' attitudes towards reporting child sexual abuse showed a statistically significant difference in terms of gender variable or not. On the other hand, One-Way Analysis of Variance - ANOVA - was used in order to test whether the attitudes of school principals towards expressing their opinions on the use of tangible materials and computers in mathematics lessons showed a statistically significant difference in terms of seniority, educational status, educational background and educational institutions or not.

### FINDINGS

The degree of participation of all opinions provided by the participant school principals on all items was found to be "Sometimes" (mean= 2.74). The Distribution of the Opinions of School principals on the Use of Tangible Materials and Computers in Mathematics Lessons According to Each Item of the Scale is shown in [Table 1](#).

**Table 1.** The distribution of the opinions of school principals on the use of tangible materials and computers in mathematics lessons according to each item of the scale

Items	N	X	SS	Degree of Participation
1. The mathematics teachers should also use resources apart from the guidebooks	184	1.71	.815	Always
2. I shall provide support for subscribing to scientific mathematics magazines in line with the demands of mathematics teachers	184	2.69	1.29	Sometimes
3. I shall procure resources for mathematics teachers apart from the guidebooks	184	2.90	1.395	Often
4. I think it would be good to have a mathematics corner in our school (such as books, tangible materials, and posters)	184	1.59	.906	Always
5. I shall refer to the opinions of mathematics teachers on the use of tangible materials during lessons	184	2.04	.942	Often
6. The teachers should use tangible materials in mathematics lessons	184	1.78	.878	Always
7. I shall support the procurement of tangible materials when mathematics teachers demand	184	2.16	1.212	Always
8. I think the duration of the lesson is enough for mathematics teachers to use tangible materials during lesson	184	2.92	1.184	Sometimes
9. I think the use of tangible materials in mathematics lessons will distract the students and the lessons will not be healthy	184	4.27	1.077	Never
10. I think the use of tangible materials in mathematics lessons will not make a positive contribution to the students (such as increasing their success or comprehension levels)	184	3.94	1.353	Never
11. I think the mathematics teachers have skills for using tangible materials in mathematics lessons	184	2.50	1.086	Sometimes
12. The mathematics teachers request my help for the procurement and use of tangible materials	184	3.17	1.113	Sometimes
13. I refer to the opinions of mathematics teachers on the use of computers in lessons	184	2.82	1.183	Often
14. The mathematics teachers should take advantage of computers during lessons	184	2.14	1.087	Often
15. I shall provide support for the procurement of the software related to mathematics and graphics drawing that mathematics teachers need	184	2.49	1.164	Often
16. I immediately interfere with the procurement and maintenance of computers and projectors	184	2.15	1.003	Often
17. I think the mathematics teachers have skills for using computers in mathematics lessons	184	2.16	.833	Often
18. I think the duration of the lesson is enough for mathematics teachers to use computers during lesson	184	2.80	1.320	Often
19. I think the use of computers in mathematics lessons will distract the students and the lessons will not be healthy	184	4.15	1.051	Never
20. I think computer-aided mathematics lessons will not make a positive contribution to the students (such as increasing their success or comprehension levels)	184	4.04	1.206	Never
21. The mathematics teachers request my help for the procurement and use of computer equipment necessary for computers and presentations	184	3.05	1.213	Sometimes

In this study, the opinions of the school principals were provided without making any changes. As can be seen in **Table 1**, "I shall support the procurement of tangible materials when mathematics teachers demand" the item had one of the highest means ( $X=2.16$ ). This item was followed by "The teachers should use tangible materials in mathematics lessons" ( $X=1.78$ ), "The mathematics teachers should also use resources apart from the guidebooks" ( $X=1.71$ ) and "I think it would be good to have a mathematics corner in our school (such as books, tangible materials, and posters)" ( $X=1.59$ ). Considering the degree of participation, the qualitative equivalents of the opinions related to these three items are 'Always'.

As can be seen in **Table 1**, the item "I shall procure resources for mathematics teachers apart from the guidebooks" had one of the highest means ( $X=2.90$ ) among the items related to the opinions of school principals on the use of tangible materials and computers in mathematics lessons. This item was followed by "I refer to the opinions of mathematics teachers on the use of computers in lessons" ( $X=2.82$ ), "I think the duration of the lesson is enough for mathematics teachers to use computers during lesson" ( $X=2.80$ ), "I shall provide support for the procurement of the software related to mathematics and graphic drawing that mathematics teachers need" ( $X=2.49$ ), "I think the mathematics teachers have skills for using computers in mathematics lessons" ( $X=2.16$ ), "I immediately interfere in the procurement and maintenance of computers and projectors" ( $X=2.15$ ), "The mathematics teachers should take advantage of computers during lessons" ( $X=2.14$ ) and "I shall refer to the opinions of mathematics teachers on the use of tangible materials during lessons" ( $X=2.04$ ). Considering the degree of participation, the qualitative equivalents of the opinions related to these items are 'Often'.



**Table 2.** T-test results of the opinions of school principals on the use of tangible materials and computers in mathematics lessons in terms of gender variable

Gender	N	Mean	Sd	df	t	p
Female	25	55.68	10.83	182	0.979	.329
Male	159	77.87	7.02			

**Table 3.** One-Way ANOVA results of the opinions of school principals in terms of the number of students in school

Variables	N	Mean	S	Sd	f	p	Resource of Difference
a. 100-601	44	57.22	10.60	4; 184	4.72	0.03	901-1300 More than 1701
b. 601-1201	55	59.36	12.37				
c. 1201-1501	30	52.47	8.59				
d. 1501-2001	20	54.35	6.55				
e. More than 2001	35	61.42	7.86				
Total	184	57.58	10.41				

As can be seen in **Table 1**, "The mathematics teachers request my help for the procurement and use of tangible materials" item had one of the highest means ( $X=3.17$ ) among the items related to the opinions of school principals on the use of tangible materials and computers in mathematics lessons. This item was followed by "The mathematics teachers request my help for the procurement and use of computer equipment necessary for computers and presentations" ( $X=3.05$ ), "I think the duration of the lesson is enough for mathematics teachers to use tangible materials during lesson" ( $X=2.92$ ), "I shall provide support for subscribing scientific mathematics magazines in line with the demands of mathematics teachers" ( $X=2.69$ ) and "I think the mathematics teachers have skills for using tangible materials in mathematics lessons" ( $X=2.50$ ). Considering the degree of participation, the qualitative equivalents of the opinions related to these items are 'Sometimes'.

As can be seen in **Table 1**, "I think the use of tangible materials in mathematics lessons will distract the students and the lessons will not be healthy" item had one of the highest means ( $X=4.27$ ) among the items related to the opinions of school principals on the use of tangible materials and computers in mathematics lessons. This item was followed by "I think the use of computers in mathematics lessons will distract the students and the lessons will not be healthy" ( $X=4.15$ ), "I think computer-aided mathematics lessons will not make a positive contribution to the students (such as increasing their success or comprehension levels)" ( $X=4.04$ ) and "I think the use of tangible materials in mathematics lessons will not make a positive contribution to the students (such as increasing their success or comprehension levels)" ( $X=3.94$ ). Considering the degree of participation, the qualitative equivalents of the opinions related to these items are 'Never'.

In line with the information in **Table 2**, it was determined that the scores of the opinions of school principals on the use of tangible materials and computers in mathematics lessons didn't show any statistically significant difference in terms of gender. One-Way ANOVA results of the opinions of school principals on the use of tangible materials and computers in mathematics lessons in terms of the number of students in the school are shown in **Table 3**.

As a result of the One-Way ANOVA performed, it was determined that the opinions of school principals on the use of tangible materials and computers in mathematics lessons showed a statistically significant difference in terms of the number of students in school [ $F(4, 184)=4.72, p<.05$ ]. In this regard, it can be said that the opinions of school principals on the use of tangible materials and computers in mathematics lessons show a statistically significant difference. The Scheffe test from multiple comparison tests was used in order to determine which means are different. According to the results of the Scheffe test (as high scores show high levels of negative attitudes), when the opinions of school principals who had 901-1300 students in their school ( $X=1.4738$ ) and the opinions of school principals who had both 16-20 years of seniority and more than 1701 students in their school ( $X=52.47$ ) were compared, it was determined that the opinions of school principals on the use of tangible materials and computers in mathematics lessons showed a statistically significant difference.

The opinions of school principals on the use of tangible materials and computers in mathematics lessons show the statistically significant difference in terms of the number of students in school. In this regard, it can be said that the use of tangible materials and computers in mathematics lessons in schools with 901-1300 students and more than 1701 students are more effective. When the data obtained from the school principals with up to 20 seniority years and the data obtained from the school principals with fewer seniority years are compared, it can be determined that the school principals exhibit more negative attitudes towards reporting child sexual abuse. However, it can be also said that after this seniority year the school principals exhibit more positive attitudes.

One-Way ANOVA results of the opinions of school principals on the use of tangible materials and computers in mathematics lessons in terms of the number of teachers in the school are shown in **Table 4**.



**Table 4.** ANOVA Results in terms of the number of teachers in school

Variables	N	Means	S	Sd	f	p	Resource of Difference
1-3	90	57.92	9.67	4; 184	4.77	0.010	1-3 More than 6
4-5	44	51.42	10.36				
6 and more	50	51.96	10.99				
Total	184	56.06	10.41				

**Table 5.** ANOVA Results in terms of the number of managers in school

Variables	N	Means	S	Sd	f	p	Resource of Difference
1-3	99	58.05	11.61	4; 184	.459	.633	No difference
4-5	59	57.54	9.25				
6 and more	26	55.84	7.86				
Total	184	57.57	10.41				

As a result of the One-Way ANOVA performed, it was determined that the opinions of school principals on the use of tangible materials and computers in mathematics lessons showed a statistically significant difference in terms of the number of teachers in school [ $F(3, 184) = 4.77, p > .05$ ]. In this regard, it can be said that the opinions of school principals on the use of tangible materials and computers in mathematics lessons show a statistically significant difference in terms of the total number of mathematics teachers working in a related school. The Scheffe test from multiple comparison tests was used in order to determine which means are different. According to the results of the Scheffe test (as high scores show high levels of negative attitudes), when the opinions of school principals who had 1-3 mathematics teachers in their school ( $X = 57.92$ ), the opinions of school principals who had 6 and more mathematics teachers in their school ( $X = 51.96$ ) and the opinions of school principals who had 4-5 mathematics teachers in their schools ( $X = 51.42$ ) were compared, it was determined that the opinions of school principals on the use of tangible materials and computers in mathematics lessons showed a statistically significant difference. The opinions of school principals on the use of tangible materials and computer in mathematics lessons show the statistically significant difference in terms of the number of mathematics teachers in school. In this regard, it can be said that the use of tangible materials and computers in mathematics lessons in schools with 1-3 and 4-5 mathematics teachers are more effective than the use of tangible materials and computers in mathematics lessons in schools with 6 or more mathematics teachers.

One-Way ANOVA results of the opinions of school principals on the use of tangible materials and computers in mathematics lessons in terms of the number of managers in school are shown in [Table 5](#).

As a result of the One-Way ANOVA performed, it was determined that the opinions of school principals on the use of tangible materials and computers in mathematics lessons didn't show any statistically significant difference in terms of the number of managers in school [ $F(3, 184) = .459, p > .05$ ]. In this regard, it can be said that the number of managers in school does not have a statistically significant effect on the opinions of school principals regarding the use of tangible materials and computers in mathematics lessons.

## DISCUSSION AND CONCLUSIONS

Mathematics is of great importance in our lives especially for describing and predicting the events happening around the world. It can be said that it is an abstraction in its pure sense as it exists independently of mankind and the world around us. Mathematics creates abstract structures of real-world counterparts with similar features and properties (Post, 1981).

As stated in studies conducted by Akinci et al. (2012), Dursun et al. (2013), and Ibarra, Santillán, Salazar, and Leyva (2017), past experiences and studies conducted so far show that technology cannot be used successfully in schools without the support of school principals. Therefore, the idea of determining the attitudes of school principals formed the basis of this study. In this study, various questions were addressed to the school principals about the use of tangible materials and computers by teachers in mathematics lessons and the following data were obtained as a result of the survey:

First, the school principals reported that tangible materials should always be used and computers should frequently be used in mathematics lessons. In fact, the same conclusion was made in an announcement published by the National Council of Teachers of Mathematics and it was reported that tangible materials and computers should be used in mathematics lessons.

It was concluded that school principals would always support the procurement of tangible materials upon the demand of teachers and they would often provide support for the procurement of the software and equipment related to the use of computers. The school principals reported that the mathematics teachers should use resources apart from the guidebooks and there should be a mathematics corner in schools. However, the school principals

also reported that they were not keen in subscribing to scientific mathematics magazines, but they would provide support for the procurement of resources apart from the guidebooks. In addition to these, it was concluded that the school principals often referred to the opinions of mathematics teachers on the use of tangible materials and computers in mathematics lessons. The school principals reported that the use of tangible materials and computers in mathematics lessons would not cause any troubles, but they were not sure whether the duration of the lesson was enough for mathematics teachers to use tangible materials during a lesson or not. However, they reported that the use of tangible materials and computers would not distract the students and it would not have a negative effect on the success of students.

The FATİH project (Movement for Increasing Opportunities and Improving Technology), which is in parallel with the results of this study, shows that the senior management institutions (Ministry of National Education and Ministry of Transportation, Turkey) have been supporting the use of tangible materials and computers in lessons and have been procuring required materials since 2010. Thus, it can be said that these efforts are in parallel with the results obtained from this study. It was also expressed that the teachers, who sometimes demanded the procurement and use of tangible materials and computers, were better at using the computers during the lesson than using tangible materials.

In conclusion, the opinions of school principals on the use of tangible materials and computers didn't show a statistically significant difference in terms of gender and the total number of managers in school, but showed a statistically significant difference in terms of the total number of students and mathematics teachers in school.

Considering both the results of this study and the data obtained from the previously published studies (the ones reviewed in this study with examples), it can be concluded that there is a consensus that additional materials should be used in mathematics lessons. As stated in the studies conducted by Nan (1994), Adigüzel et al. (2011), Akdemir (2009), Smith et al. (2005), Arikan et al. (2006), Akinci et al. (2012), Dursun et al. (2013), and Asnake, Kassahun, and Halgeyo (2017), a considerable amount of importance should be placed on the opinions of school principals in this regard. It was found in this study that the school principals supported the procurement and use of tangible materials and computers and they found it necessary to use tangible materials and computers in mathematics lessons.

## RECOMMENDATIONS

In line with the findings of this study, the following recommendations can be made:

1. The school principals are interested in the procurement or maintenance/repair of materials in line with the demands of mathematics teachers. However, this should be represented by the teachers more clearly. Thus, the perception that these demands will be met can be created.
2. The mathematics teachers can arrange testing lessons regarding the use of computers and tangible materials with school principals during in-service training. Developments can be achieved for the use of these materials in lessons.
3. School principals can determine the problems related to the materials and the use of these materials by holding regular meetings with mathematics teachers. These meetings will be more permanent if they are supervised and are aimed at submitting a final report. These meetings can be made compulsory at the beginning and, then, they can be maintained on the basis of habit and utility principles.
4. The school principals can observe the mathematics lessons in which these materials are used. At the end of these lessons, they can share the results with teachers. Thus, the use of materials in lessons can be increased and the individuals can be encouraged based on the positive feedbacks.
5. Book corners, mathematics material exhibitions or presentations including mathematics symbols arranged by the cooperation of both teachers and school principals can lead every student in the school to an interest in mathematics. A communication opportunity can be created for mathematics teachers and school principals based on these kinds of efforts. In addition to these, the teachers can be motivated and encouraged to use these materials in lessons. If a library is built, the use of additional resources can become easier for teachers.

## REFERENCES

- Adiguzel, T., Gurbulak, N., & Sarıcaır, H. (2011). Smart boards and their instructional uses. *Mustafa Kemal University Journal of Social Sciences Institute*, 15(8), 457-471.
- Akbayır, K. (2016). Primary school teachers' views with regard to the use of the material in the mathematics lesson. *The Journal of Academic Social Science Studies*, 4(33), 169-182. <https://doi.org/10.16992/ASOS.6493>

- Akdemir, E. (2009). *The investigation of the effects of using the smart board on the achievement of students in geography courses* (Unpublished master's thesis). Zonguldak Karaelmas University, Zonguldak.
- Akinci, A., Kurtoglu, M., & Seferoglu, S. S. (2012). *As a technology policy, the following must be done in order for the FATIH project to be successful: A case study*. Academic Informatics12-XIV. Academic Informatics Conference, Usak University, Usak.
- Aktumen, M. (2002). *The role of computer-assisted instruction in teaching letter expressions in elementary school 8th grade* (Unpublished master's thesis), University of Gazi, Ankara.
- Arikan, F., Aydogdu, M., Dogru, M., & Usak, M. (2006). The effect of computer-assisted learning students' achievement in biology education. *Journal of Education and Social Sciences*, 171, 177-187.
- Asnake, M., Kassahun, N., & Halgeyo, J. (2017). Mathematics teachers' and principals' perception and practice of continuous professional development (CPD) In Gedeo Zone, IASET: *International Journal of Library & Educational Science*, 3(1), 1-14
- Aydin, M. K. (2012). *The relationship between the strategic leadership actions of public and private primary school principals and the dimensions of organizational learning* (Unpublished master thesis), Gazi University.
- Aydogdu Iskenderoglu, T., Turk, Y., & Iskenderoglu, M. (2016). Pre-service Elementary Mathematics Teachers' Awareness of Ability to Use Concrete Materials and Their Self-Efficacy in the Usage Thereof in Mathematics Education. *Mehmet Akif Ersoy University, Journal of Education Faculty*, 1 (39), 1-15. <https://doi.org/10.21764/Efd.29539>
- Balci, A. (2005). *Research in Social Sciences: Methods, Techniques, and Principles*. Ankara, Turkey: Pegem Academic Publication.
- Burt, E. A. (2003). *The Metaphysical Foundations of Modern Science*. New York: Dover Publications.
- Buyukozturk, S. (2005). *Data Analysis Handbook for Social Sciences: Statistics, Research Design, SPSS Practices, and Interpretation*. Ankara, Turkey: Pegem Academic Publication
- Daghan, G., Kibar, P. N., Akkoyunlu, B., & Atanur-Baskan, G. (2015). Approaches and views of teachers and administrators related to the usage of interactive whiteboards and tablet PCs. *Turkish Journal of Computer and Mathematics Education*, 6(3), 399-417. <https://doi.org/10.16949/turcomat.42868>
- Dienes, Z. (1967). A Theory of mathematics-learning. In F. J. Crosswhite, et al. (Eds.). (1973). *Teaching mathematics: Psychology foundations*. Worthington, OH: Charles A. Jones Pub. Co. Dienes.
- Dursun, O. O., Kuzu, A., Kurt, A. A., Gullupinar, F., & Gultekin, M. (2013). Views of School Administrators' on FATIH Projects Pilot Implementation Process. *Trakya University Journal of Education Faculty*, 3(1), 100-113.
- Fuson, K. C., & Briars, D. J. (1990). Using a base-ten blocks learning/teaching approach for first and second-grade place-value and multidigit addition and subtraction, *Journal for Research in Mathematics Education*, 21, 180-206. <https://doi.org/10.2307/749373>
- Haciomeroglu, G., & Apaydin, S. (2009). Environment and Area Account for Tangram Event. *Elementary Education Online*, 8(2), 1-6.
- Ibarra, L. N., Santillán, A. G., Salazar, O. C., & Leyva, J. A. (2017). Mathematics, Technology, and Learning: How to Align These Variables in Order to Explain Anxiety Towards Mathematics and Attitude Towards the Use of Technology for Learning Mathematics, *Journal of Mathematics Science and Technology Education*, 13(9), 6211-6229. <https://doi.org/10.12973/eurasia.2017.01060a>
- Karasar, N. (2014). *Scientific research methods*. Ankara, Turkey: Nobel Publication.
- Kennedy, L. M., & Tipps, S. (1994). *Guiding children's learning of mathematics*. Belmont, CA: Wadsworth Pub. Co.
- MoNE. (2013). *Secondary school mathematics curriculum (5th, 6th, 7th and 8th grade*, Retrieved on 05.08.2017 from <https://ttkb.meb.gov.tr>
- MoNE. (2014). *Regulation on Administrative Assignment to Educational Institutions affiliated to the Ministry of National Education*. Official Gazette (June 18, 2014, Issue 29034). Retrieved from <http://www.resmigazete.gov.tr>
- Moyer, P. S. (2001). Are we having fun yet? How teachers use manipulatives to teach mathematics. *Educational Studies in Mathematics*, 47, 175-197. <https://doi.org/10.1023/A:1014596316942>
- Nan, W. (1994). *The effects of computer usage on elementary students' attitudes, motivation, and achievement in mathematics*, Ed.D (Dissertation Abstract International). Northern Arizona University.
- NIER. (1987). *School mathematics: New ideas with computers*. National Institute for Educational Research, pp. 46-47, Bangkok, Thailand.
- Piskin, M. (2010). *Investigation of pre-service elementary mathematics teachers' self-efficacy beliefs about using concrete models in teaching mathematics* (Unpublished master's thesis), Middle East Technical University.

- Post, T. (1981). The Role of Manipulative Materials in the Learning of Mathematical Concepts. In *Selected Issues in Mathematics Education* (pp. 109-131). Berkeley, CA: National Society for the Study of Education and National Council of Teachers of Mathematics, McCutchan Publishing Corporation.
- Smith, H. J., Higgins, S., Wall, K., & Miller, J. (2005). Interactive whiteboards: Boon or bandwagon? A critical review of the literature. *Journal of Computer Assisted Learning*, 21(2), 91-101. <https://doi.org/10.1111/j.1365-2729.2005.00117.x>
- Tooke, D. J. (2001). Introduction. In D. J. Tooke & N. Henderson (Eds.), *Using information technology in mathematics education*. New York: The Haworth Press, Inc. [https://doi.org/10.1300/J025v17n01\\_01](https://doi.org/10.1300/J025v17n01_01)
- Toptas, V., Celik, S. & Karaca, E. T. (2012). Pedagogical materials use of primary grade teachers in mathematics education. *Elementary Education Online*, 11(4), 1121-1130. Retrieved on 20.06.2016 from <http://ilkogretim-online.org.tr>
- Tutak, T., Kilicarslan, S., Akgul, A., Guder, Y., & Ic, U. (2012). Determination of knowledge levels of elementary school mathematics teacher candidates for the use of concrete teaching object. X. *National Science and Mathematics Education Congress*, Nigde University, 27-30 Jun 2012, Nigde, Turkey.
- Unlu, M. (2017). Investigating mathematics teachers candidates' knowledge about problem-solving strategies through problem posing, *Journal of Education and Practice*, 8(8), 218-236
- Valverde, G. A., Bianchi, L. J., & Wolfe, R. G. (2002). *According to the book: Using TIMSS to investigate the translation of policy into practice through the world of textbooks*. New York, USA: Springer Science & Business Media. <https://doi.org/10.1007/978-94-007-0844-0>
- Van de Walle, J. A. (2007), *Elementary and Middle School Mathematics. Teaching Developmentally* (6th ed.). Boston, MA: Pearson / Allyn and Bacon.
- Yenilmez, K., & Karakus, O. (2007). Opinions of elementary school and mathematics teachers on computer-aided mathematics teaching. *Mehmet Akif Ersoy University, Journal of Education Faculty*, 14, 87-98.
- Yildirim, A., & Simsek, H. (2013). *Qualitative research methods in the social sciences*. Ankara, Turkey: Seckin Publication.

<http://www.ejmste.com>

## Efficiency Evaluation and Influencing Factors Analysis of Governmental Expenditure on Preschool Education

Bin Tu<sup>1</sup>, Ying-Xian Lin<sup>2</sup>, Yi-Meng Zhang<sup>3\*</sup>

<sup>1</sup> Guangdong Research Center for NPO, Guangdong University of Foreign Studies, Guangzhou, CHINA

<sup>2</sup> School of Politics and Public Administration, Guangdong University of Foreign Studies, Guangzhou, CHINA

<sup>3</sup> Zhou Enlai School of Government, Nankai University, Tianjin, CHINA

Received 11 November 2017 • Revised 25 March 2018 • Accepted 8 April 2018

### ABSTRACT

With the DEA-Tobit analysis method and based on the panel statistic of thirty-one provinces from 1998 to 2015 in China, this paper studies the efficiency upon local government expenditure of preschool education and its' influence factors. First, the efficiencies on preschool education spending of local governments, including the overall technical efficiency, scale technical efficiency and pure technical efficiency, were evaluated by the data envelopment analysis approach (DEA). Based on the research result from the 1st step, Tobit model was used to investigate the connection of the efficiency measurement outcomes and preschool education policy variable fiscal decentralization, the connection of the efficiency measurement outcomes and social factors, such as density of population, GDP per capita and the public education degrees and so on. With the explanation of the measurement outcomes, it is noticed that the expenditure efficiency on local government preschool education has improved and have showed significant differences in CN. The influences of degree of urbanization, the density of population and education degree upon the efficiency of governmental preschool education spending and GDP per capita are positive. After the control of population, social and economic factors, the influence of fiscal decentralization upon the efficiencies on preschool education public spending is negative, the efficiencies on preschool education spending of local government has been greatly improved by preschool education policy in China.

**Keywords:** governmental expenditure efficiency, preschool education, DEA-TOBIT, education policy, fiscal decentralization

### INTRODUCTION

Preschool education has the characteristics of public welfare and externality. The government should assume the primary responsibility and obligation in the construction and development of preschool education. While ECEC (Early Childhood Education and Care) may consist of multiple fund resources, affluent government expenditure is necessary to support a sustainable, affordable and quality services system. In systems with well-functioning, governments establish clear and consistent strategies to effectively allocate resources, including infrastructure expenditure for long-term planning and ongoing quality initiatives in preschool education. If there aren't strong government expenditure and participations, it would be difficult to achieve high-quality teaching aims and broad system goals (social inclusion, gender equality, kids' health and well-being) (Bennett & Tayler, 2006). The role of government expenditure and participation cannot be separated from strong expenditure efficiency and comprehension of the factors which may play influences on expenditure efficiency.



### Contribution of this paper to the literature

- There is a significant conclusive connection Density of population is positive related to the expenditure efficiency of preschool education, which validates Grossman's viewpoint that scale economy could account for this result.
- By adjusting the preschool education resources, preschool education policy enhances the application efficiency of preschool education resources in order to take a dynamic and active part in the preschool education improvement of a nation.
- To enhance the application efficiency of public finance funds, the government can change the initially full covered financial appropriation pattern of preschool education to the financial appropriation mode on the basis of preschool education service performance.

Due to the lack of strong government expenditure and involvements in preschool education during 1998<sup>1</sup> to 2010 in China, the public has to face “the Kindergarten Crunch” which was that the public cannot enter a suitable kindergarten at an affordable level or had paid a high or unreasonable price for their children’s early childhood education (Zhou, Li, Hu, & Li, 2017). Since 2010, Chinese government has promulgated a series of policies such as National Education Reform and Development Planning in Medium and Long Term (2010-2020), Several Opinions of the State Council about the Development of Pre-school Education, etc. to strongly improve the development of preschool education (Gao & Zhang, 2017). The public finance expenditure on China’s preschool education increased from RMB 20.05 billion in 2010 to RMB 11.01 billion in 2015. The average annual rate of growth of public finance expenditure on China’s preschool education increased from 2010 to 2015 was 42.72%. The proportion of the public finance expenditure on China’s preschool education to the total-fund expenditure on the preschool education (including the public finance expenditure and non-public finance spending upon preschool education) increased from 27.9% in 2010 to 46.16% in 2015. The proportion of the public finance expenditure on China’s preschool education to total-fund spending upon education went up from 1.07% in 2010 to 3.19% in 2015 (Blankenau & Youderian, 2015). It could be seen that the scale of the public finance expenditure on preschool education has been greatly increased, so how about the efficiency of making use of these public funds? What factors affect the efficiency of the public finance expenditure on preschool education? This paper is beneficial to efficiency on preschool education funds by investigating the determinants of efficiency concerning governmental preschool education expenditure.

Researches show that the efficiency of preschool education expenditure with the data before 2013 was not high in China (Feng, 2015; Guo, 2016; Wang, 2012; Xu, 2015; Zhang, 2016). There may be several reasons to explain it as the followings. Firstly, the structure of government preschool education expenditure on public and private kindergarten would affect public expenditure efficiency. The public kindergartens that could receive much more financial subsidies from government than the private kindergartens would get better and better in quantity and quality of teachers and schoolhouse area. Charges of some public kindergartens were getting higher than before with its improvement of running condition. Most of the children who were able to enter this kind of kindergarten come from wealth families at the advantageous social level, and fewer and fewer children benefit from public finances. The undersupply of preschool education still needs an effective solution (Hu, 2015). A model of macroeconomic education was established using the data of preschool education expenditure from 1998 to 2008, it was found that in the field of preschool education responsible by public kindergartens, every 1% increase of government supporting percentage leads to 0.296% decrease of kindergarten enrollment (Zhang, 2016). Secondly, the urban and rural structure of preschool education government expenditure partial to urban kindergartens would influence the efficiency. The use efficiency of the government expenditure on rural kindergarten is lower than that on the urban kindergarten due to the number of rural kindergartens and kindergarten teachers which cannot meet the demand of rural preschool education and which need to increase (Tian, 2011). Thirdly, at different levels of government, the lack of clear division for responsibility about preschool education planning, public funds and regulation in preschool education affect the government preschool expenditure efficiency (Wang, 2012; Zhao, 2013). The efficiency of preschool education expenditure can be reflected in the distribution of benefits of preschool education expenditure. The region with highest per capita GDP and the eastern region were the biggest beneficiaries in preschool public expenditure in China, and other areas have suffered a loss of benefits. The biggest losers were not in the regions with lowest per capita GDP and western regions, but the region with lower per capita GDP and the central region. The benefit gap in different regions has shown a trend of expansion. Supporting the

---

<sup>1</sup> With the large-scale reform of state-owned enterprises from 1998, many public kindergartens run by state-owned enterprises and public institution and provided services for the children from central and low income workers’ families were closed down or amalgamate with the private. More and more private kindergarten substitute the public. Public funds supported for early childhood education has actually become less and less (Feng, 2010).



**Table 1.** Correlated Variables for Preschool Education Spending Efficiency with DEA-TOBIT

Input Variables	Output Variables	Factors Affecting Efficiency
<ul style="list-style-type: none"> <li>Public Expenditure on preschool education Personnel</li> <li>Public funds Expenditure in preschool education</li> <li>Capital construction Expenditure in preschool education</li> </ul>	<ul style="list-style-type: none"> <li>Number of Kindergartens</li> <li>Number of Classes in Kindergartens</li> <li>Number of Preschool Children in Kindergarten</li> <li>The number of full-time teachers served for per 10,000 children</li> <li>The number of full-time teachers with bachelor degree</li> <li>Average school dormitory area per student</li> </ul>	<ul style="list-style-type: none"> <li>Population Density (per/square kilometre)</li> <li>GDP per capita</li> <li>Urbanization Level (Urban Population/Total Population)</li> <li>The Level of Education</li> <li>Change of Preschool Education Policy after 2010</li> <li>Fiscal Decentralization</li> </ul>

development of private kindergartens turns out to be an efficient method to further enhance the efficiency of preschool public expenditure (Zhao, 2013).

Despite this recognition, the idea which efficiency on governmental preschool expenditure is not adequate. The measurement of the overall technical efficiency (OTE), scale technical efficiency (STE), pure technical efficiency (PTE) on local government preschool education spending and the influence factor of the efficiency are rarely mentioned. What’s the efficiency of the public expenditure on preschool education in 31 local governments after 2010? What factors will exert influence on the governmental preschool expenditure efficiency? Consequently, we fail to have an unequivocal understanding of these questions. This study explores the efficiency measurement upon the governmental expenditure of preschool education and the influence factors of efficiency. The article is divided into four parts. We give introduction to the research theme and offer a literature review in the very beginning. Then we measure the expenditure efficiency on preschool education in 31 provinces. Next, the affecting factors are analyzed upon expenditure efficiency of preschool education. In the end, we come to conclusions and offer advice on how to enhance government expenditure efficiency upon preschool education.

## PRESCHOOL EDUCATION EXPENDITURE EFFICIENCY MEASUREMENT

### DEA Method and Data

DEA (Data Envelopment Analysis) presents the non-parametric data strategy applied to measure whether Decision Making Units (DMU) of the multi-input and multi-output with same kinds is technique efficient or not (Wei, 2001). This approach is mainly for deciding the relatively efficient production frontier by remaining input or output of DMU unchanged, based on statistic and mathematical programming. Each DMU is projected onto the production frontier of the DEA, and their relative effectiveness is measured by comparing the degree to which the decision unit deviates from the DEA frontier (Cooper, Seiford, & Zhu, 2004). So as to represent the changing condition about returns to scale, this article makes use of the BCC model. The subject in this article is the expenditure efficiency on preschool education in local government, so thirty-one provinces in China are chosen as 31 DMU. Preschool education in China has changed dramatically since the large-scale reform of state-owned enterprises since 1998, thus 1998-2015 is chosen as the research period.

### Selection of Variables

The decision concerning the variables indexes can be seen in **Table 1**. The input variables include Government Spending on Preschool Education Personnel, Public Funds Expenditure on Preschool Education and Capital Construction Expenditure in Preschool Education. The output variables contain Number of Kindergartens, Number of Classes in Kindergartens, Number of Preschool Children in Kindergarten, the Number of full-time Teachers Served for per 10,000 Children, the Number of Full-time Teachers with Bachelor Degree, and Average School Dormitory Area per Student. Related statistics are from China Finance Yearbook, China Education Statistical Yearbook, China Population Statistical Yearbook and the China Education Fund Statistics Yearbook.

### Efficiency Measurement

On the basis of DEA model with the output orient, DEAP 2.1 was applied to gain the measurement outcomes of the average spending efficiency on preschool education in the provincial governments (**Figure 1**) (**Table 2**). Then, the measurement result of the OTE, PTE, and STE of the preschool education spending have been gotten analysis.

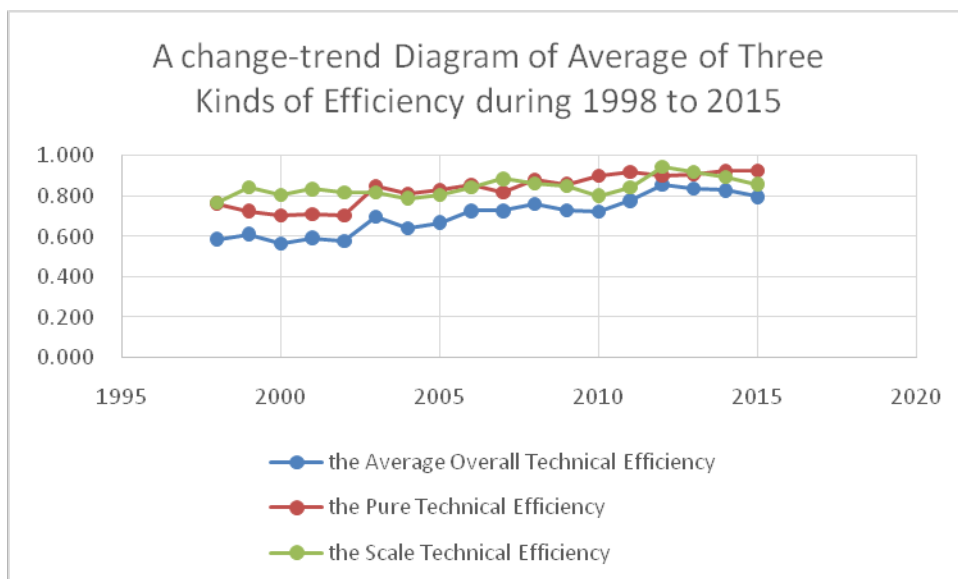


Figure 1. A Change-trend Diagram of Average of Three Kinds of Efficiency during 1998 to 2015

Table 2. Measurement Result of Preschool Education Spending Efficiency<sup>2</sup>

Province	crste	vrste	scale	rte
Beijing	0.5678	1	0.5678	drs
Tianjin	0.8735	0.9336	0.9356	irs
Jiangsu	0.6903	0.9362	0.7373	irs
Shanghai	0.5211	1	0.5211	drs
Zhejiang	0.6616	0.9228	0.7169	irs
Jilin	0.9351	1	0.9351	irs
Heilongjiang	0.7761	0.8623	0.9000	irs
Liaoning	0.8627	0.9326	0.9250	irs
Guangdong	0.8634	1	0.8634	drs
Hainan	1	1	1	-
Hebei	0.6115	0.7729	0.7912	drs
Anhui	0.6657	0.7456	0.8929	irs
Fujian	0.5716	0.7357	0.7770	irs
Shangdong	0.8556	0.9500	0.9006	irs
Jiangxi	0.8577	0.9240	0.9495	irs
Hubei	0.7249	0.8425	0.8604	irs
Henan	0.6274	0.7970	0.7872	drs
Hunan	0.8233	0.9500	0.8666	irs
Shanxi	0.6584	0.8445	0.8243	drs
Inner Mongolia	0.4629	0.7906	0.5855	irs
Guangxi	0.7584	0.8311	0.9125	irs
Chongqing	0.7240	0.8097	0.8941	irs
Sichuan	0.5277	0.7515	0.7022	irs
Guizhou	0.6103	0.7357	0.8295	irs
Yunnan	0.5080	0.6046	0.8402	irs
Tibet	0.7740	0.9208	0.8406	drs
Shanxi	0.4902	0.7536	0.6505	irs
Gansu	0.5019	0.6568	0.7642	drs
Qinghai	0.5992	0.7470	0.8021	drs
Ningxia	0.6513	0.7626	0.8541	irs
Xinjiang	0.2760	0.6305	0.4377	irs

Notes: crste: the OTE, vrste: the PTE, scale: the STE, rte: scale returns (drs: diminishing returns to scale, -: scale remuneration unchanged, irs: Increased scale returns, crste=vrste×scale)

<sup>2</sup> Beijing, Tianjin, Shanghai and Chongqing are Municipalities.

## Result and Discussion

The OTE presents a measurement of the whole efficiency of DMU. It's described in **Figure 1** that more than an seventeen-year process, the average value of OTE on preschool education expenditures in China was basically within a range of 0.5 to 0.6 before 2005, a range of 0.7 to 0.8 from 2006 to 2010, above 0.8 after 2011. The extent of variation was comparatively large before 2004, and it became small after that. It means that there was a steady upward trend on the expenditure efficiency of government preschool education.

Both the STE and PTE were fluctuating within a narrow margin prior to 2008. After 2008, though it was on the decline in some specific years, the whole variation was on the rise. In general, the average PTE, the average OTE and STE of preschool education spending of the provinces in China were all on the rise.

As to technical efficiency and scale efficiency, non-DEA efficient preschool education spending efficiency can be analyzed respectively. The OTE is acquired by STE and PTE. In other words, the non-DEA efficiency of OTE is decided by both STE and PTE for deeper reason explanation and applies to measure the loss of efficiency of preschool education spending, which also means that, to what degree, the loss of efficiency results from the STE or the PTE. With the precondition of fixed preschool education public spending scale, PTE indicates the degree of budget management and the local reasonable level of preschool education plan in government. On the premise of fixed input, STE represents the percentage of the output of the production frontier to that in the ideal scale. The higher the scale efficiency, the closer the production scale of DMU to the ideal production scale. Furthermore, by adjusting the limited condition, the kind of returns to scale of DMU could be measured through the alterable returns to scale in the data envelopment analysis model. When increasing returns to scale is appeared, it shows that DMU may enhance the production efficiency by the expansion in the scale of production. When decreasing returns to the scale is appeared, the input construction is required to be regulated to enhance the efficiency of production.

As for province differences, important difference was noticed in the OTE of preschool education spending in 31 provinces in **Table 2**. The OTE of Hainan province which is located in the eastern is one, and both the PTE and the STE are 1, indicating that the DEA of this province was the most efficient which constitute the frontier of preschool education spending efficiency. The resource distribution of the preschool education spending of this province reaches the optimal outcome compare with other regions, and the efficiency was high. The average value of overall technical efficiency was 0.6784 in all 31 provinces. It's obvious that the preschool education spending of the most of provinces in China are relatively non-DEA effective from 1998 to 2015. The OTE of ten provinces is less than 0.6. Specifically, OTE of Shanxi and Xinjiang are lower than that of other 8 provinces. Besides, the majority of the west provinces' preschool education spending efficiency were comparatively lower than that of the other provinces. The mean value was 0.7468 for the east provinces <sup>3</sup>, 0.6924 for the central part <sup>4</sup> and 0.5837 for the west part <sup>5</sup>. The average preschool education spending efficiency was comparatively high among the eastern part, comparatively low among the western part. The difference was significant between central and eastern provinces and western provinces.

From the **Table 2**, it can be concluded that the PTE of Beijing, Jilin, Shanghai and Guangdong were efficient while their scale technical efficiency is not high. It means that the relatively lower STE mainly resulted in the non-DEA efficiency of these four regions. Due to the exceeding from the optimal scale on the preschool education expenditure, the STE is supposed to be enhanced under the condition of remaining reasonable level of budget management and preschool education local plan at present. Tianjin, Jiangxi, Guangxi and Liaoning had the comparatively high measurement value in scale efficiency, which was approaching to the efficient scale efficiency. Although those places are in the situation of non-efficiency of PTE. It shows that the low OTE in the provinces was chiefly caused by the PTE. Therefore, it is supposed to pay attention to the improvement of the budget management abilities and the preschool education local plan abilities. Xinjiang has the lowest OTE in the all provinces, which was chiefly resulted from the PTE. The reason for comparatively low OTE in the majority of the western regions mainly lied in the loss PTE and the low of STE. It could be seen from **Table 3** that the scale inefficiency was the main influencing factor. In addition, as for the returns to scale, the majority of the preschool education spending of local governments are at the stage of diminishing returns scale, in other words, once the local preschool education spending increases the amount of the whole input resources by the same percentage, it will not improve efficiency. It might not be the most excellent decision to blindly seek for the increase of the scale in preschool education spending. Nevertheless, for local government, a larger proportion of input would obtain more returns by decreasing returns to scale.

<sup>3</sup> There are 17 provinces, municipalities and SAR in eastern China, which are Jiangsu, Shanghai, Zhejiang, Fujian, Guangdong, Shandong, Anhui, Hainan, Heilongjiang, Liaoning, Jilin, Hebei, Tianjin, Beijing, Hong Kong, Macao and Taiwan. We only count the front 14 provinces because we cannot get the complete data for the remaining 3 provinces.

<sup>4</sup> There are 6 provinces in central China, which are Henan, Hubei, Hunan, Jiangxi, Shanxi, and Inner Mongolia.

<sup>5</sup> There are 11 provinces and municipalities in western China, which are Shanxi, Ningxia, Gansu, Sichuan, Chongqing, Guizhou, Guangxi, Yunnan, Tibet, Qinghai, and Xinjiang.

**Table 3.** Returns to Scale in Provincial Preschool education Spending

	Increased Scale Returns (irs)	Scale Remuneration unchanged (-)	Diminishing Returns Scale (drs)
Province	Tianjin, Inner Mongolia, Liaoning, Jilin, Heilongjiang, Jiangsu, Zhejiang, Anhui, Fujian, Jiangxi, Shandong	Hainan	Beijing, Hebei, Shanxi, Shanghai, Henan, Guangdong, Sichuan, Shanxi, Tibet, Gansu, Qinghai

## INFLUENCE FACTOR ON EFFICIENCY ANALYSIS

### The Fundamental Hypothesis

The factors influencing the preschool education spending efficiency of local government in **Table 1** can be seen based on previous literature <sup>6</sup> about the influence factors in expenditure efficiency. GDP per capita, the density of population, and the level of urbanization and education level are respectively selected as the economic, demographic and social factors influencing the expenditure efficiency. Moreover, the effect of fiscal decentralization and preschool education policy after 2010 are studied on preschool education spending efficiency of local government. It's obvious that on the basis of the analysis of the 2nd part, difference has obviously existence in the preschool educational spending efficiencies of the western, middle and eastern regions. The dummy variables of the western, middle and eastern provinces will be exactly introduced for in-depth demonstration <sup>7</sup>. Based on conclusion from previous study, this article puts forward the following hypotheses concerning the factors which might bring influence on the efficiency variance of local preschool education spending.

**Hypothesis 1 (H1):** Per capita GDP is positively correlated with the efficiency of preschool education expenditure. The higher the GDP per capita, the higher the standard of living, the more conducive to the healthy development of people's health. To a certain extent, it will enhance the management efficiency and the efficiency of the using on preschool education financial funds.

**Hypothesis 2 (H2):** The rate of urbanization shows positively related to the spending efficiency on the preschool education. The higher the degree of urbanization, the more powerful the urban public infrastructure acting on rural region, and the urbanization level exerts significant influence upon the integrated public goods supply in urban and rural, then influencing the spending efficiency (Lin, 2005).

**Hypothesis 3 (H3):** The density of population has positive relation with the preschool education spending efficiency. Because of the effect of scale economy, larger density of population is benefit to the reduction of the managing and supervising cost of governmental spending, and conducive to obtain scale economy of public service supply for the developing size of inhabitants, thus giving rise to the growth of the spending efficiency. It's found that the density of populations supposed to have the positive connection with efficiency of the governmental spending (Grossman, Mavros, & Wassmer, 1999). Furthermore, Athanassopoulos (2003) noticed that the density of population and the total amount of population show negative effect on the government efficiency.

**Hypothesis 4 (H4):** The education degree has positive connection with the preschool education spending efficiency. Inhabitants with better education degree have higher preschool education demands for them, their demands can be clearly expressed by a variety of channels. Correspondingly, the government has the pressure of increase the public spending and improve the efficiency in this area. Thus, the higher education degree of inhabitants is benefit to improvement of the local governments' spending efficiency (Milligan, Moretti, & Oreopoulos, 2004). The education degree is represent by average years of schooling.

**Hypothesis 5 (H5):** Fiscal decentralization has relation with preschool education spending efficiency. Fiscal decentralization was the fundamental system arrangement in public finance after reform of tax sharing system in China in 1994. Fiscal decentralization could impact the size, structure, performance and efficiencies on local public fiscal spending. The mainstream theory in the theoretical circles about fiscal decentralization holds that the competition among local governments might inspire initiatives of the local governments to continuously take measure to enhance the providing efficiency on public goods and make contributions to the improvement of the overall social public welfare (Zhou, Sun, & Lee, 2017).The proportion of the provincial financial budget spending per capita in the total financial budget spending(include the provincial and the central) per capita is selected as the measurement index of fiscal decentralization <sup>8</sup>. At the same time, as to research the different influences of public

<sup>6</sup> Some variable adopted by Han (2010) is used for Reference.

<sup>7</sup> The eastern region are taken as the reference region and the intercept coefficient of the constant term in the model as the average expenditure efficiency level of the eastern region to test the statistical significance of the efficiency variances between the three regions.

<sup>8</sup> The fiscal decentralization index adopted by Qiao (2005) is used for reference.

finance policy upon the eastern, middle and western regions. It would be used in the model for the interaction item of fiscal decentralization variables and three region dummy variables.

**Hypothesis 6 (H6):** Preschool education policy represents a significant factor influencing the efficiency on preschool education expenditure. In order to alleviate the increasingly prominent contradiction between supply and demand in preschool education, the Outline of the State Medium and Long-run Educational Reform and Development Planning from 2010 to 2020 promulgated in 2010 in China has pointed out that various channels should be adopted to increase investment in preschool education, and government preschool education funds should occupy a reasonable proportion of the funds for government education expenditure. Provinces (autonomous regions and municipalities) were explicitly required to formulate and implement a three-year preschool education plan (Chen, 2009). Here, we introduce annual dummy variables to represent changes in preschool education policies during this period. Taking into account the lag of policy, it is stipulated that dummy variables will be set one after 2010 and zero in other years. Meanwhile, for the sake of finding out the different impacts of preschool education policies on the eastern, western and central regions, it would be used in the model for the interaction term of the dummy variable including the preschool education policies and the 3 regions as well. On the basis of the history of the development of preschool education, the article indicated that policy would also be a significant factor influencing the preschool education spending efficiency (Hong, Liu, Ma, & Luo, 2015). As a result, the effects of two policy variables, fiscal decentralization and preschool education policy, would be found out in the model.

### Model and Empirical Result

On the basis of the above hypotheses, the following relate regression model could be obtained:

$$z_{it} = \beta_{i0} + \beta_{i1}\chi_{i1} + \beta_{i2}\chi_{i2} + \beta_{i3}\chi_{i3} + \beta_{i4}\chi_{i4} + \beta_{i5}D_{ij} + \varepsilon_{it} \quad (1)$$

$z_{it}$  is the measurement result of OTE of 31 provinces on preschool education expenditure in CN from 1998 to 2015,  $\chi_{i1}$ ,  $\chi_{i2}$ ,  $\chi_{i3}$  and  $\chi_{i4}$  are the GDP per capita in every year of the research period (RMB per capita), the density of population (amount of population per square km), degree of urbanization (the percentage of amount of city population to whole amount of population), educational degree (represented by average years of schooling). Index of fiscal decentralization  $D_{ij}$  is the dummy variables which impact the overall technical efficiency on preschool education spending, involving the dummy variable for preschool education policies and the eastern, middle and western and the interaction item of the dummy region dummy variable and policy variable as well.

Due to the measurement value from 0 to 1 on OTE and for the sake of avoiding the biased error resulted from OLS measurement, the cross-section and time series data were made full use. The constrained panel data model with Tobit random-influence was adopted to make the regression analysis. Related data in this research is from Financial Statistics Yearbook of China and Statistical Yearbook of China in every year from 1999 to 2016. By applying Eviews 6.0 to Tobit analysis, the regression outcomes of the 5 models can be obtained from [Table 4](#).

**Table 4.** The Empirical Result of Affecting Factors for the Spending Efficiency of Local Government Preschool Education

Influence Factor	Model 1	Model 2	Model 3	Model 4	Model 5
Density of Population	0.0001*** (0.280)	0.00083*** (0.035)	0.00006** (0.001)	0.00009 (0.0039)	0.00021** (0.041)
GDP Per Capita	0.0699*** (0.028)	0.0138*** (0.275)	0.0703*** (0.051)	0.0986** (0.286)	0.0623** (0.043)
The Level of Urbanization	0.0818* (0.005)	0.0676* (0.0006)	0.00023** (0.000)	0.00093** (0.000)	0.00638*** (0.000)
Educational Level	0.01097*** (0.0002)	0.00336** (0.000)	0.01651** (0.0009)	0.0113*** (0.0011)	0.00695* (0.0003)
Fiscal Decentralization		-0.50038** (0.016)		-0.31386*** (0.000)	-0.39198*** (0.003)
Western dummy Variable (D2)	0.31041*** (0.000)	-0.41506** (0.001)		-0.35681** (0.000)	0.29568*** (0.0003)
Central dummy Variable	-0.51682** (0.000)	-0.42563*** (0.000)		-0.29865** (0.000)	-0.43657** (0.000)
Preschool education Policy dummy Variable (P)				0.21392*** (0.003)	
D1×Fd			-0.43976** (0.012)		
D2×Fd			-0.36597 (0.325)		
D3×Fd			-0.61723*** (0.005)		
D1×P					0.13254*** (0.003)
D2×P					0.043035 (0.379)
D3×P					0.064966** (0.031)
Constant Term	1.10564*** (0.000)	1.503518** (0.000)	0.69638*** (0.000)	0.92364*** (0.000)	1.95896*** (0.000)
Effects of Individual Standard Deviations	0.46589*** (0.000)	0.30576*** (0.000)	0.35786*** (0.000)	0.31289*** (0.000)	0.31685*** (0.000)
Interference Item Standard Deviation	0.080235*** (0.000)	0.089564*** (0.000)	0.092567*** (0.000)	0.095893*** (0.000)	0.086891*** (0.000)
Likelihood-ratio Test (Chi-square)	389.561	302.352	295.468	294.475	316.297
rho	0.879521	0.838965	0.831479	0.830454	0.842412
Log Likelihood	231.487	238.663	240.418	243.535	256.456

Note: "\*\*\*\*", "\*\*\*" and "\*\*" indicate the pass the pattern specification tests at the Significant degrees 0.01, 0.05 and 0.1

## Discussion

From Table 4, it's clear for middle and western region dummy variables that the coefficients are negative dummy in the first, second, fourth and fifth Model. For the central area, the second and fourth Model are significant on the five percent level, the rest whereat the one percent level. For the western region with the exception of the second Model, which is exactly significant at the one percent level. The other models are clearly significant at the five percent level. The results indicate that the central and western regions have comparatively less governmental preschool education expenditure efficiency compared to the eastern region, this further reflects the above analysis results of the OTE on preschool education spending.

It suggests from the results that the density of population has positive relation with the spending efficiency of preschool education and significantly in line with the null hypothesis. Obviously, two of the five models indicate a significant and relatively positive connection of the degree of urbanization and the preschool education spending efficiency. The result shows that the greater the degree of urbanization is, the more powerful the capability of production elements transfer between city and rural and the higher influence of preschool education are. There is a significant conclusive connection the density of population is clearly positively related to the spending efficiency of preschool education, which validates Grossman's viewpoint that scale economy could account for this result (Grossman & Zhang, 1993).

The second, fourth and fifth Model all contain fiscal decentralization variable. In the second Model it was found that, at the 5% significance level, a relation between the fiscal decentralization variable and preschool education expenditure efficiency is negative. However, when the preschool education policy variable was involved in the fourth and fifth Model, the influence of fiscal decentralization upon the preschool education spending efficiency remains clearly negative and obviously significant at one percent level. The significance turns out to be clearer,



showing that good robustness has been in the result. Such result is deviated from the fiscal decentralization mainstream theory of which is that fiscal decentralization is positive correlative with government spending efficiency. It could be understood through Chinese fiscal decentralization mechanism.

Chinese fiscal decentralization is not so as the other nations, it has close connection with the centralized political mechanism, in which the most vital performance target for local government is rate of economic growth, the officials in local government hold greater motivation, which is to improve the size and efficiency of financial spending, and to obtain great output in short-term, but the fiscal preschool educational spending and the efficiency that could not be simply enhanced in short time is frequently neglected.

Although there is a clear legal requirement on expenditure on education, the budget for education within the budget increases in accordance with the law, and the goal of 4% of the total government expenditure on education is required. Local governments pay more attention to ensuring compulsory education, high school education and college education expenditure, while the fiscal expenditure laws and regulations in preschool education is seriously lagged behind and cannot be clearly determined (Wu, 2014).

So as to have in-depth investigation about the difference effects of fiscal decentralization upon the preschool education spending efficiency from different regions, the interaction item, which could be reflected fiscal decentralization and dummy variables of the central, western and eastern region, gets involved in the third Model. The outcomes indicate from **Table 4** that, the influence of fiscal decentralization upon preschool education spending efficiency of central and western region is much better than the eastern region. At the same time, the significance of the influence is five percent and one percent respectively for the central part and west part, while not clear for the eastern part. This conforms to the earlier outcome of efficiency accounting, indicating that the overall technical efficiency of local preschool education spending in China is relatively high in the eastern part, and comparatively low in the western and central region (Han & Miao, 2010). As a result, moderate financial centralization might be adopted so as to bridge the efficiency differences among the eastern, central and western parts.

Based on the log likelihood value from the five models showed in the **Table 4**, it can be seen that the fourth model and the fifth model fit greater than the previously three models, indicating that preschool education policy variables introduced into the model are significant factors affecting preschool education expenditure efficiency. In order to check the effect of preschool education policy upon the preschool education expenditure efficiency around 2010, the dummy variables of preschool education policy are included in the fourth model. The results validate the hypothesis that preschool education policies around 2010 have significantly increased the efficiency of preschool education in China. The interactive item of the dummy variable of preschool education policy and the dummy variable of the eastern, middle and western regions gets involved into the fifth Model. The results show that preschool education policy can significantly promote the preschool education spending efficiency in eastern and middle regions of China, while the western region is positive but not obvious. Therefore, the following conclusions can be drawn: preschool education policies around 2010 can reduce the difference in government preschool education expenditure efficiency among eastern, central and western parts (Qiao, Fan, & Feng, 2005).

## CONCLUSIONS

This article uses the DEA 2-step approach to measure the three type of efficiency of the governmental preschool education spending in 31 Chinese provinces from 1998 to 2015. The research outcomes indicate that, there is a local difference on preschool education expenditure efficiency in China, and the efficiency on local preschool education spending in the eastern part is larger than the west and middle regions. Most of the loss of overall efficiency is chiefly resulted from the scale efficiency. It might not be the most excellent decision to improve efficiency through blindly pursuing the expansion of the size of preschool education spending for the diminishing returns scale province. In the future, it is necessary to optimize the structure of preschool expenditure (Yue et al., 2018).

According to the measurement outcomes of overall efficiency of preschool education costs, the random influence Tobit model is deeply applied to explain the factors influencing provincial governmental preschool education expenditure efficiency and the following and obviously conclusion is shown: GDP per capita, degree of urbanization, density of population and education degree all have positive correlation with influence upon the efficiency of preschool education spending.

The impact of fiscal decentralization upon the efficiency on preschool education spending is relatively negative after the control of the factor about society, economy and population. Moderate financial centralization could be taken to reduce the efficiency difference among the east, central and west parts. The practice of preschool education policies can significantly promote the expenditure efficiency of local government preschool education in middle and western regions of China, and the present preschool education policy is able to be constantly carried out to decrease the efficiency difference among the governmental preschool education spending of the east, middle and west parts.

From the viewpoint of public finance policy, relatively moderate financial centralization in the current economic system is helpful for enhancing the government expenditure efficiency. Moreover, local governments which show decreasing returns to scale should adjust and optimize spending structure on preschool education to get rid of the loss of efficiency, while for those which show increasing returns to scale, the government is supposed to increase preschool education expenditure to enhance the efficiency. To enhance the application efficiency of public finance funds, the government can change the initially full covered financial appropriation pattern of preschool education to the financial appropriation mode on the basis of preschool education service performance, i.e., the pattern of particular public funds for preschool education services can be applied, and the particular public funds for preschool education improvement in private kindergarten and rural kindergarten. Besides, various financial support patterns should be taken for various kinds of preschool education products. For the pure preschool education products and services that the social strengths are frequently reluctant to provide, the government administration department is supposed to take the full responsibility. For the quasi-public products and services that the social strengths are capable but reluctant to offer, the department is supposed to take the form of government purchases; for products and services of preschool education the social forces are willing and capable of offering such as self-managed preschool education organizations the government should give appropriate subsidies through rewards.

From the preschool education policy perspective, continuously deepening the reform of preschool education development strategy and arranging a variety of local preschool education resources more suitably are also significant approaches to enhance the efficiency of the governmental preschool education spending. It's necessary to improve information disclosure mechanism in use of preschool education funding. Specifically, regularly government funding information for preschool education and specific directions, and the details of expenditures of the user of government funds on preschool education both should be disclosed. Meanwhile, it is supposed to strengthen preschool education funding supervision and evaluation mechanism (Pan, Wang, & Li, 2018). By adjusting the preschool education resources, preschool education policy enhances the application efficiency of preschool education resources in order to take a dynamic and active part in the preschool education improvement of a nation. As a result, it is necessary to further deepen the reform of preschool education system.

## ACKNOWLEDGEMENTS

The research supported by Guangdong Natural Science Foundation Project (Granted No.2017A030313426), the Key Projects (Interdisciplinary) of the National Social Science Foundation of China (Granted No.15ZDB173).

## REFERENCES

- Athanassopoulos, A. D. (2003). Strategic groups, frontier benchmarking and performance differences: evidence from the UK retail grocery industry. *Journal of Management Studies*, 40(4), 921-953. <https://doi.org/10.1111/1467-6486.00365>
- Bennett, J., & Tayler, C. P. (2006). *Starting Strong II: Early Childhood Education and Care*. Paris: OECD.
- Blankenau, W., & Youderian, X. (2015). Early childhood education expenditures and the intergenerational persistence of income. *Review of Economic Dynamics*, 18(2), 334-349. <https://doi.org/10.1016/j.red.2014.06.001>
- Chen, S., & Zhang, J. (2009). Empirical research on fiscal expenditure efficiency of local governments in China. *Social Sciences in China*, 30(2), 21-34. <https://doi.org/10.1080/02529200902981103>
- Cooper, W. W., Seiford, L. M., & Zhu, J. (2004). Data envelopment analysis. In *Handbook on data envelopment analysis* (pp. 1-39). Springer, Boston, MA. <https://doi.org/10.1007/978-1-4899-7553-9>
- Feng, X. X. (2015). Developing universal inclusive kindergarten is the fundamental solution to the difficulty of kindergarten crunch. *Preschool Education Research*, 5, 4-6. <https://doi.org/10.1787/9789264276116-en>
- Gao, X., & Zhang, B. (2017). An Overview of Early Childhood Science Education in China. In *Chinese Science Education in the 21st Century: Policy, Practice, and Research* (pp. 39-57). Springer, Dordrecht. [https://doi.org/10.1007/978-94-024-1004-4\\_4](https://doi.org/10.1007/978-94-024-1004-4_4)
- Grossman, G. M., & Helpman, E. (1993). *Innovation and growth in the global economy*. Cambridge, MA: MIT press. <https://doi.org/10.2307/2554862>
- Grossman, P. J., Mavros, P., & Wassmer, R. W. (1999). Public sector technical inefficiency in large US cities. *Journal of Urban Economics*, 46, 278-299. <https://doi.org/10.1006/juec.1998.2122>
- Guo, Y. F. (2016). Inter-provincial comparison and analysis of preschool education funding efficiency, *Preschool Education Development*, 20, 27-33.

- Han, W. H., & Miao, Y. G. (2010). Efficiency Accounting and Impact Factors of Local Government Health Spending Research. *Journal of Finance and Economics*, 5, 4- 15.
- Hong, X., Liu, P., Ma, Q., & Luo, X. (2015). The way to early childhood education equity-policies to tackle the urban-rural disparities in China. *International Journal of Child Care and Education Policy*, 9(1), 5. <https://doi.org/10.1186/s40723-015-0008-9>
- Hu, B. Y. (2015). Comparing cultural differences in two quality measures in Chinese kindergartens: The early childhood environment rating scale-revised and the kindergarten quality rating system. *Compare: a Journal of Comparative and International education*, 45(1), 94-117.5. <https://doi.org/10.1080/03057925.2013.841468>
- Lin, W. L. (2005). Economy development degree under the bridle of urban and rural public goods providing. *Rural Observations in China*, 2, 31-37.
- Milligan, K., Moretti, E., & Oreopoulos, P. (2004). Does Education Improve Citizenship? Evidence from the United States and the United Kingdom. *Journal of public Economics*, 88, 1667-1695. <https://doi.org/10.1016/j.jpubeco.2003.10.005>
- Pan, Y., Wang, X., & Li, L. (2018). Early Childhood Education and Development in China. In *International Handbook of Early Childhood Education* (pp. 599-622). Springer, Dordrecht. [https://doi.org/10.1007/978-94-024-1004-4\\_7](https://doi.org/10.1007/978-94-024-1004-4_7)
- Qiao, B. Y., Fan, J. Y., & Feng, X. Y. (2005). Fiscal decentralization and primary obligation Education in China. *Chinese Social Sciences*, 6, 37- 46.
- Tian, Z. L. (2011). Problems and Reform of Financial Investment in Preschool Education in China. *Journal of Beijing Normal University (Social Science Edition)*, 5, 7-22.
- Wang, S. J. (2012). Efficiency of Preschool Education for Financial Input and Government Responsibility. *Education and Economy*, 3, 5-7.
- Wei, Q. (2001). Data envelopment analysis. *Chinese Science Bulletin*, 46(16), 1321-1332.
- Wu, P. C. (2014). *Preschool education investment in financial law security research*. Anhui University, Anhui, China.
- Xu, D. (2015). *Research on the Efficiency of Preschool Education Supply in China*. Beijing Institute of Technology, Beijing, China.
- Yue, A., Tang, B., Shi, Y., Tang, J., Shang, G., Medina, A., & Rozelle, S. (2018). Rural education across China's 40 years of reform: past successes and future challenges. *China Agricultural Economic Review*, 10(1), 93-118. <https://doi.org/10.1108/caer-11-2017-0222>
- Zhang, X. (2016). Preschool Education Reform of Fiscal Policy Effect Evaluation - Based on Local Government Preschool Education Cost Sharing Perspective, *Education Development Research*, 24, 29-36.
- Zhao, H. (2013). Benefit Distribution of Public Expenditure in Pre-primary Education, *Educational Development Studies*, 15, 62-68.
- Zhou, J., Sun, J., & Lee, D. P. L. (2017). Trends in Government Expenditure in Early Childhood Education in China: Practices in Shanghai, Guizhou, and Ningshan. In *Early Childhood Education in Chinese Societies* (pp. 71-84). Springer, Dordrecht. [https://doi.org/10.1007/978-94-024-1004-4\\_5](https://doi.org/10.1007/978-94-024-1004-4_5)
- Zhou, Y., Li, H., Hu, B. Y., & Li, L. (2017). On the road to universal early childhood education in China: A financial perspective. *International Journal of Educational Development*, 53, 137-144. <https://doi.org/10.1016/j.ijedudev.2017.01.004>

<http://www.ejmste.com>



For print copies of this issue or articles please send an e-mail to:

[print@modestum.co.uk](mailto:print@modestum.co.uk)

# The Effects of Watching Authentic English Videos with and without Subtitles on Listening and Reading Skills of EFL Learners

Rastislav Metruk <sup>1\*</sup>

<sup>1</sup> Department of English Language and Literature, Zilinska Univerzita v Ziline, Zilina, SLOVAKIA

Received 14 February 2018 • Revised 11 April 2018 • Accepted 11 April 2018

## ABSTRACT

Watching English videos can be considered as a powerful and popular tool with regard to learning English as a foreign language, and ought to be devoted serious attention by teachers and researchers. The present study attempts to explore the potential effects of watching authentic English videos (movies, TV shows, etc.) with subtitles (English and Slovak) and without subtitles on listening and reading skills. A total of thirty Slovak university EFL learners were divided into three groups according to their viewing preference: English subtitle group (ESG), Slovak subtitle group (SSG), and no subtitle group (NSG). Afterwards, the participants in each group underwent listening and reading tests, and their scores were subsequently examined. The test results were analyzed and compared using the Analysis of Variance (ANOVA) statistical method and the Bonferroni post-hoc test. Overall, neither listening nor reading test scores exhibit statistically significant differences between the three groups, although the post-hoc test, which was used for comparing the groups with each other, revealed that a significant difference was detected between the ESG and SSG within the analysis of reading test scores.

**Keywords:** authentic English videos, subtitles, listening skills, reading skills, EFL learner

## INTRODUCTION

The four language skills – listening, reading (receptive skills), speaking, and writing (productive skills) are deemed to be the focus of L2 (second language, foreign language) classes, and both teachers and learners ought to attach major importance to all of them. Traditional methods of foreign language teaching primarily concentrated on reading and writing, paying scant attention to the skills of listening and speaking (Raissi, Nor, Aziz, Zainal & Saleh, 2013). According to CLT (Communicative Language Teaching), however, the four skills are integrated, and a particular emphasis is placed on listening and speaking (Rees-Miller, 2017). Alternatively, Korkmaz and Güneyli (2017) recognize the considerable significance of reading and listening since the productive skills cannot be acquired without gaining the receptive ones. Thus, all four skills should be incorporated within the process of EFL (English as a foreign language) teaching.

Although listening and reading skills are often referred to as passive language skills, as opposed to the skills of speaking and writing (active skills), Bordonaro (2014) explains that both listening and reading can also be deemed active. Listening in L2 can be considered as an active skill since the listeners are required to cope with a number of complicated tasks such as differentiating between phonemes or interpreting stress and intonation (Ghoneim, 2013). Thus, it is something of a misnomer to label this skill passive (Gilakjani & Ahmadi, 2011). Similarly to listening, reading is also normally thought of as a passive skill, although according to (Fu, 2012, p. 54), “[r]eading is an active skill, which constantly involves guessing, predicting, checking and asking oneself questions”. Dangsaart, Naruedomkul, Cercone, and Sirinaovakul (2008) and Pčolinská (2008) also assert that reading is an active skill involving a reader, text, and the interaction between them, and that it is a dynamic and interactive process. Thus, listening and reading also seem to fall into the categories of active skills rather than the passive ones.

### Contribution of this paper to the literature

- The study examines the impact of watching English videos with or without subtitles by exploring the difference in listening and reading test scores between ESG, SSG, and NSG.
- The analyses reveal that overall, no statistically significant difference was detected between the three groups within the listening and reading test scores.
- The Bonferroni post-hoc test, which was used for comparing the groups with each other, indicates that there is a significant difference between the ESG and SSG within reading test scores.

As far as teaching the receptive skills is concerned, it was the skill of listening which has long been neglected despite its obvious importance within L2 learning (Gilakjani & Ahmadi, 2011; Kavaliauskienė, 2008; Kazemi & Kiamarsi, 2017; Yildiz, Parjanadze & Albay, 2015). Teachers and academics have to remember that devoting scant attention to any of the two receptive skills may have serious consequences for the overall proficiency of a learner, and that the development of productive skills (speaking and writing) may be seriously hampered. As has been previously mentioned, L2 learners are barely capable of gaining the skills of speaking and writing without acquiring the skills of reading and listening.

“Life informatization” imposes new demands on using ICT (information and communication technologies) at each level of the educational system (Baş, Kubiato & Sünbül, 2016; Fedina, Burmykina, Zvezda, Pikalova, Skudnev & Voronin 2017). Technical and technological development has induced changes in every sphere of society, including education (Doulík, Škoda & Šimonová, 2017). In a similar way, Krause, Pietzner, Dori, and Eilks (2017, p. 4406) state that “[w]ith the development of technology changing both people’s lives and people’s relations within societies, education is also undergoing innovations and necessary reforms”. It is also the Internet which has a substantial influence on education (Qiao & Wang, 2017) since it provides ample opportunity for learning a language in a new and unconventional manner. One such example, which illustrates using the ICT technologies or the Internet in education, is watching movies, TV shows, and authentic videos by L2 learners in order to develop their proficiency in the target language either with or without subtitles.

The principal objective of the study is to explore the effects of watching English videos with and without English subtitles on the listening and reading skills of Slovak university EFL students by examining the differences in listening and reading test scores between the three groups (ESG, SSG, NSG). Another goal of this paper is to perform a comparison of groups with each other (ESG vs SSG, ESG vs NSG, SSG vs NSG) using the Bonferroni post-hoc test.

## LITERATURE REVIEW

### Listening

General findings of several studies indicate that using subtitles and captions when watching videos or TV programs is a powerful instructional tool in relation to learning vocabulary and enhancing reading and listening comprehension skills of L2 learners (Karakas & Sariçoban, 2012). Similarly, Yuksel and Tanriverdi (2009) maintain that most of the research conducted in the field suggests that using subtitles and captions is valuable in terms of improving the language skills of L2 learners.

Research in the Slovak field of using L1 and L2 subtitles while watching authentic English videos and their effect on language skills of Slovak EFL learners is scarce. Therefore, it is hoped that this paper will help fill in the gap in research concerning this important matter.

Yang and Chang (2013) conducted a study on the contribution of three modes of English captions (full, keyword-only, and annotated keyword captions) towards learning English reduced forms and the overall listening comprehension. The results showed that all three groups demonstrated improvement. The annotated keyword captioned group demonstrated the best performance with the highest mean score.

The study carried out by Ghasemolani and Nafissi (2012) demonstrated that using captions had a significant effect on the listening comprehension of the subjects involved since the group in which English captions were present outperformed the other group (this group did not use the captions).

Another paper by Hayati and Mohmedi (2011) supports the value of using English subtitles for improving English listening skills of Iranian EFL learners. According to the study, the group which used English subtitles outperformed the group using Persian subtitles, which in turn outperformed the no subtitle group in the listening test.

Rokni and Ataee (2014) investigated the potential effect of using English movie subtitles on listening comprehension of EFL Iranian students. The results of this study demonstrated that the English subtitle group achieved higher scores on the listening test in comparison to the no subtitle group.



Similarly, Shamsaddini, Ghanbari, and Nematizadeh (2014) investigated the effect of watching movies with and without subtitles on the listening comprehension of Iranian EFL learners. The students who used English subtitles while watching English video outperformed the students who did not use subtitles.

Opposing the idea, the study of Başaran and Köse (2013) examined the influence of English captions, Turkish captions, or no captions on listening comprehension of intermediate and low-intermediate level EFL learners. Their findings revealed that the subjects in all three conditions scored similarly on the listening comprehension test.

Another paper by Latifi, Mobalegh, and Mohammadi (2011) also explored the influence of using subtitles on the development of listening comprehension. The results showed that despite the fact that the MC (multiple choice) tests data suggest a positive effect for both types of subtitles (Bimodal and Standard subtitling) on the immediate comprehension of the students, none of the two subtitling procedures lead to the improvement of listening comprehension in general.

## Reading

“Improving the reading comprehension skills of students has become an important issue in educational and civilian institutes” (Lee & Chang, 2016, p. 1501). As far as using subtitles in relation to improving the skill of reading is concerned, some studies (Borras & Lafayette, 1994; Danan, 2004) supported the notion that audio-visual materials which are enhanced by subtitles seem to improve L2 reading and listening comprehension skills.

In their quasi-experiment, Lwo and Lin (2012) investigated the effects of captions on L2 learning of teenagers. The results demonstrated that the effects of different captions within multimedia L2 learning in regard to vocabulary acquisition and reading comprehension is dependent upon the L2 proficiency of students.

The study of Kruger and Steyn (2013), which was performed in the context of English subtitles on English academic lectures, indicates that there exists a significant positive correlation between comprehension and subtitle reading, producing some evidence to suggest that using subtitles in reading instruction and L2 learning is favorable.

Another study conducted by Koolstra, Voort, and Kamp (1997) suggests that viewing subtitled TV programmes results over time to improved reading skills in children.

BavaHarji, Alavi, and Letchumanan (2014) explored the effects of viewing captioned videos on EFL learners’ content comprehension, vocabulary acquisition, and language proficiency. The results revealed that the effects of watching captioned instructional videos are stronger on acquiring vocabulary and enhancing language proficiency than on content comprehension. However, the results within the reading comprehension section demonstrated favourable effects of captioned instructional video.

Hwang and Huang (2011) examined the effects of watching captioned video on reading comprehension of Taiwanese university freshmen. The findings showed that subjects watching captioned video did not achieve higher scores in the reading test when compared to the subjects who did not use subtitles.

There is no doubt that watching videos represent a powerful and attractive educational tool for EFL learners. This paper attempts to shed more light on the effect of watching captioned videos on both listening and reading skills of university EFL learners.

## METHODOLOGY

### Research Design

The objective of this study is to examine the effect of watching authentic videos, both with subtitles (English and Slovak) or without subtitles, on listening and reading skills. To achieve this, the participants were divided into three groups (watching authentic English videos with English subtitles, with Slovak subtitles, or without subtitles). Next, all the participants underwent a reading test and a listening test. Afterwards, the data were analyzed, results were interpreted, and conclusions drawn.

### Subjects

The study employed a total of 30 university students (3<sup>rd</sup> year B.A. students and 1<sup>st</sup> year M.A. students) of the study programme Teaching of English Language and Literature at a university in Slovakia, who were formed by 24 females and 6 males. On average, they were 22.2 years of age, and all of them were of Slovak nationality, residing in Slovakia. Each participant had been studying English for more than 10 years.

The students were chosen on the basis of 53 questionnaire responses of Slovak university EFL students; only 30 eligible participants out of the 53 completed questionnaires were selected so as to create homogenous groups. All

30 participants were at an approximately similar English proficiency level – the CEFR (Common European Framework of Reference for Languages) level B2+ according to the university criteria.

### Data Collection and Procedure

A short questionnaire ([Appendix 1](#)) was applied in order to obtain the data concerning the participants' preferences for watching authentic English videos. The students who claimed to watch authentic English videos either *every other day* or *two – three times per week* (so that the participants were more or less homogeneous in terms of their exposure to English videos) were subsequently divided into three groups (according to their preferences for subtitles use):

1. Students who watch authentic English videos with English subtitles – English subtitle group (ESG);
2. Students who watch authentic English videos with Slovak subtitles – Slovak subtitle group (SSG);
3. Students who watch authentic English videos using no subtitles – no subtitle group (NSG).

Subsequently, each group was given the same standardized reading and listening test in order to investigate the relationship between watching videos with or without subtitles and listening and reading comprehension test scores. The participants could achieve the maximum of 28 points for the listening section (18 items, fill-in-the-blank and multiple choice test) and 30 points for the reading section (15 items, multiple choice test). Afterwards, the data were compared and analysed using the analytics software *Statistica 10.0* in order to investigate whether the differences in test results between the three groups are statistically significant.

### Results

Listening and reading scores are showed in [Table 1](#), [Figure 1](#), and [Figure 2](#). The highest mean score for listening test was detected in the SSG, followed by the NSG, and ESG. The highest average score for reading test was found in the ESG, followed by the NSG, and SSG.

**Table 1.** Listening and reading test scores

English subtitle group			Slovak subtitle group			No subtitle group		
Subject	Listening	Reading	Subject	Listening	Reading	Subject	Listening	Reading
1	16	28	11	24	26	21	14	26
2	19	26	12	14	30	22	13	22
3	25	26	13	18	24	23	27	28
4	24	30	14	27	20	24	18	28
5	14	20	15	22	20	25	23	16
6	23	30	16	25	28	26	7	16
7	14	28	17	14	20	27	26	20
8	22	20	18	25	20	28	24	30
9	11	24	19	15	12	29	21	20
10	11	10	20	16	6	30	22	30
<b>Mean</b>	<b>17.9</b>	<b>24.2</b>	<b>Mean</b>	<b>20</b>	<b>20.6</b>	<b>Mean</b>	<b>19.5</b>	<b>23.6</b>

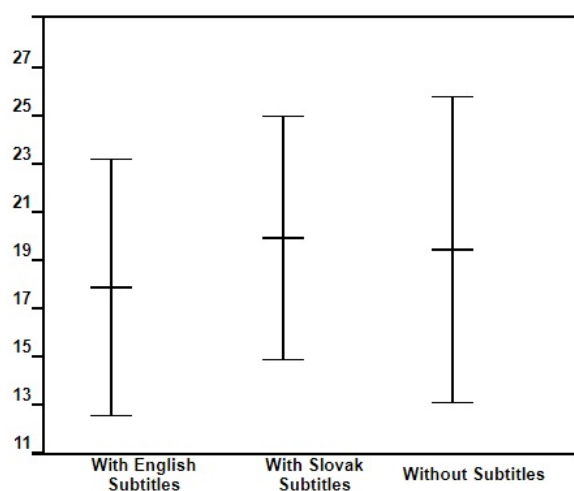


Figure 1. Listening test scores

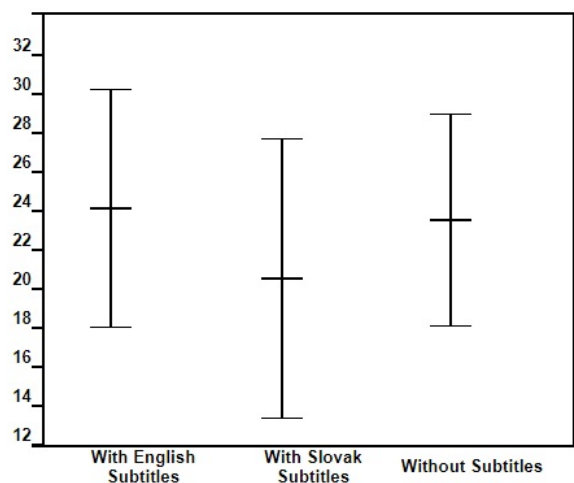


Figure 2. Reading test scores

It is, however, important to determine whether the differences in the obtained data are statistically significant. The ANOVA statistical model and the Bonferroni post-hoc test were applied to explore the difference between the test scores of all three groups.

The main findings are as follows. No statistically significant difference was observed between the three groups within the analysis of listening test scores ( $F = 2.00$ ;  $p = 0.37$ ;  $W = 0.11$ ). Similarly, the analysis of reading test scores between the three groups did not reveal a statistically significant difference ( $F = 4.67$ ;  $p = 0.1$ ;  $W = 0.23$ ). Thus, watching English authentic videos either with or without subtitles did not seem to produce significant effect on the test scores.

Afterwards, the test scores of particular groups were compared with each other. The Bonferroni post-hoc test was used to consider the difference in the test scores between the ESG, SSG, and NSG groups. The comparison of listening test scores (Table 2) did not show statistically significant differences between the three groups. However, the post-hoc test within the reading scores (Table 3) demonstrates that there is a statistically significant difference between the ESG and SSG ( $p < 0.05$ ), which means that the test scores of ESG were significantly better when compared to the test scores of SSG. The comparison of ESG vs NSG and SSG vs NSG did not indicate a significant difference.

Table 2. Bonferroni post-hoc test for listening test scores

Treatments pair	p-value	Difference
ESG vs SSG	0.21	not significant
ESG vs NSG	0.59	not significant
SSG vs NSG	0.38	not significant

**Table 3.** Bonferroni post-hoc test for reading test scores

Treatments pair	p-value	Difference
ESG vs SSG	0.04	significant
ESG vs NSG	0.85	not significant
SSG vs NSG	0.38	not significant

## DISCUSSION, RECOMMENDATION AND CONCLUSION

In spite of the fact that some differences between the mean scores of listening (ESG = 17.9, SSG = 20.0, NSG = 19.5) and reading (ESG = 24.2, SSG = 20.6, NSG = 23.6) were observed, the ANOVA test reveals that overall, there is no statistically significant difference between the three groups within the analysis of listening and reading test scores. Further comparison of groups with each other (ESG vs SSG, ESG vs NSG, SSG vs NSG), performed on the basis of the Bonferroni post-hoc test, does not show significant differences in terms of the listening test scores. However, comparing the three groups with each other in terms of the reading test scores revealed that while no significant differences were observed within the comparison of ESG vs NSG and SSG vs NSG, a statistically significant difference was detected within the comparison of ESG vs SSG ( $p < 0.05$ ). This finding seems to indicate that watching English videos with L2 subtitles (rather than L1 subtitles) could lead to improved reading comprehension.

Based on this small-scale study, it can be concluded that the findings do not support the assumption that the ESG would outperform the NSG or the SSG subtitle group when it comes to examining the effect of subtitles on listening skills. The situation is similar when it comes to reading; although the Bonferroni post-hoc test, which was used for comparing the groups with each other, indicates that the difference between the ESG (24.2) and SSG (20.6) within reading comprehension is statistically significant, no significant difference was found overall according the ANOVA statistical method.

The results of this study indicate that the use of L1 or L2 subtitles does not bring about an important effect when it comes to the relationship between watching authentic English videos with or without subtitles and listening comprehension; using the subtitles neither improves nor impedes listening comprehension. Overall, the same can be concluded about the relationship between watching English videos with or without subtitles and reading comprehension, although some effect was detected in this instance (ESG reading test scores were significantly better in comparison to SSG reading test scores according to the post hoc-test). Thus, it appears that watching English videos with English subtitles could be more beneficial to EFL learners' reading comprehension skills than using Slovak (Czech) subtitles. However, this finding needs to be verified by conducting further research into the field of subtitles and L2 acquisition.

On the whole, it can be concluded that the findings do not appear to be in line with those of Ghasemband and Nafissi (2012), Hayati and Mohmedi (2011), Rokni and Ataei (2014), or Shamsaddini, Ghanbari, and Nematizadeh (2014). On the contrary, the results seem to be in agreement with the findings of Başaran and Köse (2013), Hwang and Huang (2011), or Latifi, Mobalegh, and Mohammadi (2011).

One of the limitations of this study lies in employing a relatively small sample size, which can somewhat lower the generalizability of the findings. Thus, performing the study on a larger sample size and employing subjects consisting of EFL learners at other CEFR levels than B2+ would definitely prove useful and helpful.

Watching authentic English videos represents a powerful and popular tool when it comes to learning languages, and ought to be devoted considerable attention by teachers and researchers. There is no doubt that further research and investigation into the effect of subtitles (both L1 and L2) on listening and reading skills is necessary as it would shed more light on the use of videos with and without subtitles in L2 acquisition.

## REFERENCES

- Baş, G., Kubiato, M., & Sünbül, A. (2016). Teacher's Perceptions towards ICTs in Teaching-learning Process: Scale Validity and Reliability Study. *Computers in Human Behavior*, 61, 176-185. <https://doi.org/10.1016/j.chb.2016.03.022>
- Başaran, H., & Köse, G. (2013). The Effects of Captioning on EFL Learners' Listening Comprehension. *Procedia - Social and Behavioral Sciences*, 70, 702-708. <https://doi.org/10.1016/j.sbspro.2013.01.112>
- BavaHarji, M., Alavi, Z., & Letchumanan, K. (2014). Captioned Instructional Video: Effects on Content Comprehension, Vocabulary Acquisition and Language Proficiency. *English Language Teaching*, 7(5), 1-16. <https://doi.org/10.5539/elt.v7n5p1>

- Bordonaro, K. (2014). *The Intersection of Library Learning and Second-Language Learning. Theory and Practice*. Plymouth, England: Rowman & Littlefield.
- Borras, I., & Lafayette, R. (1994). Effect of Multimedia Courseware Subtitling on the Speaking Performance of College Students of French. *The Modern Language Journal*, 78(1), 61-75. Retrieved from <http://www.jstor.org/stable/329253>
- Danan, M. (2004). Captioning and Subtitling: Undervalued Language Learning Strategies. *Meta*, 49(1), 67- 77. <https://doi.org/10.7202/009021ar>
- Dangsaart, S., Naruedomkul, K., Cercone, N., & Sirinaovakul, B. (2008). Intelligent Thai Text - Thai Sign Translation for Language Learning. *Computers & Education*, 51(3), 1125-1141. <https://doi.org/10.1016/j.compedu.2007.11.008>
- Doufík, P., Škoda, J., & Šimonová, I. (2017). Learning Styles in the e-Learning Environment: The Approaches and Research on Longitudinal Changes. *International Journal of Distance Education Technologies*, 15(2), 45-61. <https://doi.org/10.4018/IJDET.2017040104>
- Fedina, N., Burmykina, I., Zvezda, L., Pikalova, O., Skudnev, D., & Voronin, I. (2017). Study of Educators' and Parents' Readiness to Implement Distance Learning Technologies in Preschool Education in Russia. *EURASIA Journal of Mathematics Science and Technology Education*, 13(12), 8415-8428. <https://doi.org/10.12973/ejmste/80802>
- Fu, Y. (2012). A Study on Strategies-Based Reading Instruction at College Level. *Studies in Literature and Language*, 4(3), 50-54. <https://doi.org/10.3968/j.sll.1923156320120403.3650>
- Ghasemboland, F., & Nafissi, Z. (2012). The Effects of Using English Captions on Iranian EFL Students' Listening Comprehension. *Procedia - Social and Behavioral Sciences*, 64, 105-112. <https://doi.org/10.1016/j.sbspro.2012.11.013>
- Ghoneim, N. (2013). The Listening Comprehension Strategies Used by College Students to Cope with the Aural Problems in EFL Classes: An Analytical Study. *English Language Teaching*, 6(2), 100-112. <https://doi.org/10.5539/elt.v6n2p100>
- Gilakjani, A., & Ahmadi, M. (2011). A Study of Factors Affecting EFL Learners' English Listening Comprehension and the Strategies for Improvement. *Journal of Language Teaching and Research*, 2(5), 977-988. <https://doi.org/10.4304/jltr.2.5.977-988>
- Hayati, A., & Mohmedi, F. (2011). The Effect of Films with and without Subtitles on Listening Comprehension of EFL Learners. *British Journal of Educational Technology*, 42(1), 181 - 192. <https://doi.org/10.1111/j.1467-8535.2009.01004.x>
- Hwang, P., & Huang, P. (2011). Using Subtitles to Enliven Reading. *English Language and Literature Studies*, 1(1), 2-6. <https://doi.org/10.5539/ells.v1n1p2>
- Karakas, A., & Sariçoban, A. (2012). The Impact of Watching Subtitled Animated Cartoons on Incidental Vocabulary Learning of ELT Students. *Teaching English with Technology*, 12(4), 3-15. Retrieved from <http://www.tewtjournal.org/issues/past-issue-2012/past-issue-2012-issue-4/>
- Kavaliauskienė, G. (2008). Podcasting: a Tool for Improving Listening Skills. *Teaching English with Technology*, 8(4).
- Kazemi, A., & Kiamarsi, S. An Investigation into Listening Comprehension Strategies and the Relationship between Listening Comprehension Strategies and Overall Proficiency Level of Intermediate and Advanced Learners. *Journal of Language Teaching and Research*, 8(1), 149-156. <https://doi.org/10.17507/jltr.0801.18>
- Koolstra, C., Voort, T., & Kamp, L. (1997). Television's Impact on Children's Reading Comprehension and Decoding Skills: A Three-year Panel Study. *Reading Research Quarterly*, 32(2), 128-152. Retrieved from <http://www.jstor.org/stable/748102>
- Korkmaz, S., & Güneyli, A. (2017). Impact of Technology-Assisted Context-Based Teaching on the Listening Skills of Teacher Candidates. *EURASIA Journal of Mathematics Science and Technology Education*, 13(8), 4669-4677. <https://doi.org/10.12973/eurasia.2017.00957a>
- Krause, M., Pietzner, V., Dori, Y., & Eilks, I. (2017). Differences and Developments in Attitudes and SelfEfficacy of Prospective Chemistry Teachers Concerning the Use of ICT in Education. *EURASIA Journal of Mathematics Science and Technology Education*, 13(8), 4405-4417. <https://doi.org/10.12973/eurasia.2017.00935a>
- Kruger, J., & Steyn, F. (2013). Subtitles and Eye Tracking: Reading and Performance. *Reading Research Quarterly*, 49(1), 105-120. <https://doi.org/10.1002/rrq.59>
- Latifi, M., Mobalegh, A., & Mohammadi, E. (2011). Movie Subtitles and the Improvement of Listening Comprehension Ability: Does it help? *The Journal of Language Teaching and Learning*, 1(2), 18-29. Retrieved from <http://oaji.net/articles/2015/2313-1439501098.pdf>

- Lee, C., & Chang, C. (2017). Using the Networked Peer Support Strategy to Enhance Reading Comprehension for Students with Various Thinking Styles. *EURASIA Journal of Mathematics Science and Technology Education*, 13(5), 1501-1515. <https://doi.org/10.12973/eurasia.2017.00682a>
- Lwo, L., & Lin, M. (2012). The Effects of Captions in Teenagers' Multimedia L2 Learning. *ReCALL - the Journal of the European Association for Computer Assisted Language Learning (EUROCALL)*, 24(2), 188-208. <https://doi.org/10.1017/S0958344012000067>
- Pčolinská, A. (2008). *Uplatňovanie princípov komunikatívneho prístupu v procese cudzojazyčnej výučby* [Employing the Principles of Communicative Approach in the Process of Foreign Language Teaching]. Praha, Czech Republic: Alfa.
- Qiao, F., & Wang, H. (2017). Mobile Interactive Translation Teaching Model Based on "Internet +". *EURASIA Journal of Mathematics Science and Technology Education*, 13(10), 6705-6714. <https://doi.org/10.12973/ejmste/78191>
- Raissi, R., Nor, F., Aziz, M., Zainal, Z., & Saleh, Z. (2013). Student's Understandings and Practices Regarding Communicative Language Teaching (CLT) in Malaysian Secondary Schools. *Mediterranean Journal of Social Sciences*, 4(4), 325-330. <https://doi.org/10.5901/mjss.2013.v4n4p325>
- Rees-Miller, J. (2017). Second Language Pedagogy: Where Theory Meets Practice. In M. Aronoff & J. Rees-Miller (Eds.) *The Handbook of Linguistics* (2<sup>nd</sup> ed.), pp. 585-602. Hoboken, USA: John Wiley & Sons Ltd.
- Rokni, S., & Ataee, A. (2014). Movies in EFL Classrooms: with or without Subtitles. *The Dawn Journal*, 3(1), 715-726. Retrieved from <http://thedawnjournal.in/wp-content/uploads/2013/12/4-Dr.-Seyed.pdf>
- Shamsaddini, M., Ghanbari, B., & Nematizadeh, S. (2014). The Effect of Watching Movies with and without Subtitles on Iranian EFL Learners' Listening Comprehension. *Modern Journal of Language Teaching Methods*, 4(2), 168-177.
- Yang, J. & Chang, P. (2013). Captions and Reduced Forms in Instruction: the Impact on EFL Students' Listening Comprehension. *ReCALL - the Journal of the European Association for Computer Assisted Language Learning (EUROCALL)*, 26(1), 44-61. <https://doi.org/10.1017/S0958344013000219>
- Yildiz, N., Parjanadze, N., & Albay, M. (2015). The Effect of Question Position on Listening Comprehension: A Case Study. *International Journal of Social Sciences & Educational Studies*, 2(1), 4-9. Retrieved from <http://ijsses.org/wp-content/uploads/2017/12/The-Effect-of-Question-Position-on-Listening-Comprehension-A-Case-Study.pdf>
- Yuksel, D., & Tanriverdi, B. (2009). Effects of Watching Captioned Movie Clip on Vocabulary Development of EFL Learners. *The Turkish Online Journal of Educational Technology*, (8)2, 48-54. Retrieved from <http://tojet.net/articles/v8i2/824.pdf>



## APPENDIX 1

### Questionnaire

**Name and surname:**

**Age:**

**Gender:**

**I watch authentic English videos (movies, TV shows, etc.) in English**

Every day

Every other day

Two to three times a week

Once a week

Once in two weeks

Once a month

**I usually watch authentic English videos (movies, TV shows, etc.) in English**

With English subtitles

With Slovak (Czech) subtitles

Without subtitles

**<http://www.ejmste.com>**



<http://www.ejmste.com>



<https://twitter.com/ejmste>



<https://www.facebook.com/ejmste>



<http://modestum.co.uk/>



[publications@modestum.co.uk](mailto:publications@modestum.co.uk)

## Effects of Changed School Entry Rules: Age Effects within Third Grade Students

Özgür Öner<sup>1</sup>, Öykü Çalışır<sup>2,3,4</sup>, Nazife Ayyıldız<sup>2,4,5</sup>, İpek Çelikağ<sup>2</sup>, Pınar Uran<sup>6</sup>, Sinan Olkun<sup>7\*</sup>, Metehan Çiçek<sup>2,4,8</sup>

<sup>1</sup> Bahçeşehir University, School of Medicine, Department of Child and Adolescent Psychiatry, Istanbul, TURKEY

<sup>2</sup> Ankara University Brain Research Center, Ankara, TURKEY

<sup>3</sup> Ankara University, Faculty of Educational Sciences, Psychological Counseling and Guidance Unit, Ankara, TURKEY

<sup>4</sup> Ankara University Institute of Health Sciences, Department of Interdisciplinary Neuroscience, Ankara, TURKEY

<sup>5</sup> Department of Mathematics Education, Institute of Educational Sciences, Ankara University, Ankara, TURKEY

<sup>6</sup> Ankara University School of Medicine, Child and Adolescent Psychiatry Department, Ankara, TURKEY

<sup>7</sup> TED University Department of Mathematics and Science Education, Ankara, TURKEY

<sup>8</sup> Ankara University School of Medicine, Department of Physiology, Ankara, TURKEY

Received 15 November 2017 • Revised 5 February 2018 • Accepted 11 March 2018

### ABSTRACT

It has been reported that young age of school onset has important effects on academic and behavioral outcomes. Although there are studies using multinational data, data from low and middle income countries are few. As part of a larger study about mathematics learning difficulties, the aim of the present study was to evaluate the age of school entry on mathematics ability and general ability in standard tests and emotional and behavioral problems reported by their teachers among 2058 third grade students in Ankara, second biggest and capital city of Turkey. Results indicated lower mathematics and general abilities and higher hyperactivity/impulsivity, inattention and emotional problems scores as well as less prosocial behavior in the youngest group of children. Effect sizes were largest for general ability and mathematics ability. Our data were largely consistent with previous studies from other countries, and extended the literature by providing data from a middle income country.

**Keywords:** school entry, age effect, math achievement

### INTRODUCTION

In Turkey, due to changes in law on school entry age (primary school, first grade), parents have faced a challenge as they had to make a decision. There is a graded system on school entry age: children older than 72 months are mandatory to enter school, children between 69-72 months may not enter school when parents provide a document from physicians indicating that the child is not ready for school, children between 66-68 months may not enter school when parents do not apply, children between 60-65 months may enter school if parents apply, and children who are younger than 59 months may not enter the first grade. This complex legal system leads to a mix of children with different ages in the same grade. Several parents applied to hospitals and clinics to have official medical documents indicating that their children are not eligible to enter school system, for they had concerns about their performance and adjustment at school.

Their concern is not without reason. Children who enter school one year later have 13% lower risk of repeating grade (Elder & Lubotsky, 2009), and achieve better at school (Lien, Tambs, Oppedal, Heyerdahl, & Bjertness, 2005). On the other hand, effect of schooling age on adult labor market performance seems not to be significant (Dobkin & Ferreria, 2010). Using Trends in International Mathematics and Science Study (TIMSS) data, researchers showed

© 2018 by the authors; licensee Modestum Ltd., UK. This article is an open access article distributed under the terms and conditions of the Creative Commons Attribution License (<http://creativecommons.org/licenses/by/4.0/>).

✉ [ozgur.oner@yahoo.com](mailto:ozgur.oner@yahoo.com) ✉ [ocalisir@education.ankara.edu.tr](mailto:ocalisir@education.ankara.edu.tr) ✉ [nazifeayyildiz@gmail.com](mailto:nazifeayyildiz@gmail.com)

✉ [ipekcelikag@gmail.com](mailto:ipekcelikag@gmail.com) ✉ [pınaruran1@yahoo.com](mailto:pınaruran1@yahoo.com) ✉ [sinanolkun@gmail.com](mailto:sinanolkun@gmail.com) (\*Correspondence)

✉ [Metehan.Cicek@ankara.edu.tr](mailto:Metehan.Cicek@ankara.edu.tr)

### Contribution of this paper to the literature

- In many countries, the age is a very important variable in school entry. So it would be valuable to know if it makes any effect on students' academic and general achievements during the school years.
- It is also important to know the effect of dramatic changes in school entry rules.
- Findings on the effects of younger age of school entry on academic and behavioral outcomes are not clear. Although there are studies using multinational data, data from low and middle income countries are few. The present study evaluates the effects of age of school entry on mathematics ability and general ability in standard tests and emotional and behavioral problems reported by their teachers among third grade students.

that youngest students in fourth and eighth grades have significantly lower standardized test scores when compared with oldest students (Bedard & Dhuey, 2006), indicating the longer run impact of relative age.

Effects of being younger-for-grade are not restricted to academic performance. Attention deficit hyperactivity disorder (ADHD) diagnosis is increased in younger children (Elder & Lubotsky, 2009). Children born just under the cutoff date of kindergarten entry are less likely to be diagnosed ADHD and to be treated with a stimulant (Evans, Morrill & Parente, 2010). Teacher reports are very important for ADHD diagnosis and teachers compare children with their peers. These findings call to attention the importance of relative standards in ADHD diagnosis (Elder, 2010).

Relatively younger age at school entry is also associated with higher risk of problems other than ADHD. Younger-for-grade students have been reported to be more likely classified as having learning disabilities (Dhuey & Lipscomb, 2008; Gledhill, Ford, & Goodman, 2002; Martin, Foels, Clanton, & Moon, 2004). Muhlenweg (2010), based on data from 17 countries, showed that relatively younger students were are commonly victims of school violence. Another study reported higher rates of teenage pregnancy among younger school entrants (Black, Devereux, & Salvanes, 2011). It has also been showed that children who entered school younger has a higher risk of being hyperactive at age 8 (but not age 11); at age 11 they were less adaptive to change. Those children who were relatively older at school entry has increased self-esteem years later (Thompson, Barnsley, & Battle, 2004). In a large cross-sectional study, Goodman and associates reported that relatively younger children at school had higher scores at both teacher and parent reports; they were also at increased odds of having a psychiatric diagnosis. Authors commented that the results were consistent with "relative age" explanation rather than "season of birth" explanation (Goodman, Gledhill, & Ford, 2003). However, early school entry did not have a significant impact on IQ (Mühlenweg, Blomeyer, Stichnoth & Laucht, 2012).

On the other hand, previous literature is not totally conclusive. Morrison and colleagues (Morrison, Griffith, & Alberts, 1997) found that relatively younger children made as much progress as older children at first grade. These children also made more progress than they would if they were in kindergarten. Several other studies reported no disadvantage of being younger for cohort in academic, behavioral or social terms (Buntaine & Costenbender, 1997; De Meis & Stearns, 1992; Jones & Mandeville, 1990; McNamara, Scissons, & Simonot, 2004). When the other side of the coin is examined, delayed entry to school may also lead to both positive and negative results. Taken together, most of the studies showed that delayed entry to school has "no, little, negative or diminishing effects" (Martin, 2009).

Therefore, effects of younger age of school entry on academic and behavioral outcomes are not clear. Although there are studies using multinational data, data from low and middle income countries are few. The aim of the present study was to evaluate age of school entry on mathematics ability and general ability in standard tests and emotional and behavioral problems reported by their teachers among third grade students in Ankara, second biggest and the capital city of Turkey.

In sum, we collected data from third grade students by using general ability and mathematics ability tests and teacher questionnaires. We divided the sample into three groups based on their age of school entry (early entrants, correct age for entry and late entrants). We investigated the effect of the age of school entry on mathematics performance and some behavioral measures by taking into account the socioeconomic status, general ability and teacher reports about the students.

## METHODS

### Sample

Sample was part of a study on dyscalculia in third grade students. The parent study has three stages: screening, dyscalculia assessment and functional magnetic resonance imaging. For the first stage, 13 primary state schools at Ankara center were selected to represent lower, medium and higher socioeconomic backgrounds. At the screening

phase, all students at the third grade from the selected schools were included. 2058 third grade student from these schools were screened with general ability (Raven's Standard Progressive Matrices) and mathematics ability tests (Mathematics Achievement Test and Calculation Performance Test) and screening questionnaires filled by their teachers (Swanson, Nolan, and Pelham -IV Questionnaire and Strengths and Difficulties Questionnaire). Data collected from 143 subjects were incomplete; therefore, 1915 subjects were included in data analysis. Raven's test and mathematics achievement tests were conducted by trained researchers in two separate sessions. Ankara University Internal Review Board approved the study.

## Measurements

Swanson, Nolan, and Pelham -IV Questionnaire (SNAP-IV): Items include 18 ADHD symptoms, 9 in each hyperactivity/impulsivity and inattention subscales. Items are rated on 4 point scale from (0) not at all to (3) very much. Average rating per item (ARI) subscale score is calculated by adding all points in the subscale and dividing it by 9. SNAP-IV is reported to be a reliable and valid instrument (Bussing et al., 2008). In our study, teachers completed the SNAP-IV.

Strengths and Difficulties Questionnaire (SDQ, Goodman et al, 2001): SDQ gets information on 25 attributes, which are divided into 5 scales: emotional symptoms, conduct problems, hyperactivity-inattention, peer problems and prosocial behaviors. Extended forms include an impact supplement which provides information on whether the respondent thinks that the child has a problem and the impact of the problem in terms of social impairment, burden, chronicity and overall distress. SDQ has satisfactory reliability and validity (Goodman, 2001). Turkish form is also reported to be valid and reliable (Güvenir et al., 2008). We used SDQ Teacher form in the study.

Raven Progressive Matrices (RPM): We used Standard Progressive Matrices (SPM). SPM includes 5 sets of a total of 60 diagrammatic puzzles with increasing difficulty. Test has been reported to have good reliability and validity (Raven, 2000).

Mathematics Achievement Test (MAT, Fidan, 2013): It includes counting, number patterns and basic calculation, and based on Turkish Ministry of Education mathematics curriculum. It takes almost 45 minutes to complete the test. Cronbach alpha coefficient is 0.93 for third grade.

Calculation Performance Test (De Vos, 1992; Olkun, Can, & Yeşilpınar, 2013): The test consists of 5 columns of arithmetic calculations (subtraction, multiplication, division, addition and mixed). One minute is allowed for each column and total correct answers are taken into account.

Data Analysis: Based on age of school entry, the sample was divided into three groups: early entrants (age of entry: 61-65 months, n=89), correct age for entry (age of entry: 66-77 months, n=1337), late entrants (age of entry: >78 months, n=464). Socioeconomic status (based on school district, low: n=837, middle: n=1078), gender (male: 947, 49.5%), Raven's SPM scores were other independent factors. Data on Kindergarten attendance was obtained from 1565 subjects, and was included in separate analysis and reported only when different from the main analysis. First, in univariate analysis of variance (ANOVA), we investigated the effects of each independent variable on mathematics achievement tests, SNAP-IV Hyperactivity/Impulsivity and Inattention ARI scores, SDQ Total Problems and Prosocial Behaviors scores. Second, we used logistic regression analysis to investigate the relative effects of the independent variables. In these models, Raven SPM score, age of school onset group, socioeconomic status (SES), and gender were independent factors. Analysis were performed separately for each outcome. Outcomes were defined as being in the lowest 10th percentile for MAT, CPT, SDQ Prosocial Behaviors scores, or in the higher 10th percentile for SDQ Total Problems, SNAP-IV Hyperactivity/Impulsivity and Inattention ARI scores. In the binary logistic regression analysis, the outcomes were coded as 1 and other cases were coded as 0. Values of  $p < .05$  were reported as statistically significant.

## RESULTS

Age groups: MAT, CPT and SPM were available for 1904, 1900 and 1898 students, respectively. SDQ and SNAP-IV were available for 1621 and 1580 students, respectively. Current age range of the sample was 87 to 123 months. Girl to boy ratio was not statistically significant between age groups,  $\chi^2(1, N=1904) = 1.8, p=0.4$ .

### Univariate Effects of Independent Variables on Mathematics Ability and Teacher Ratings

**1- Age of school entry:** Descriptives were summarized in **Table 1**. Results indicated that mathematics ability,  $F(2, 1883) = 23.7; p < .001$ , general ability  $F(2, 1879) = 21.4; p < .001$ , and prosocial behaviors  $F(2, 1630) = 6.2; p = .002$ , increased significantly with age of school entry among third grade students. On the other hand, SDQ Total Problems score  $F(2, 1651) = 4.4; p = .01$ , and SNAP-IV based attention problems  $F(2, 1604) = 14.4; p < .001$ , and hyperactivity/impulsivity  $F(2, 1604) = 7.0; p < .001$ , decreased with age of school entry. However, all effect sizes were very small ( $\eta^2$  between 0.006 and 0.025).

**Table 1.** Comparisons among the groups based on the age of school entry

	Age of School Entry			Significance	
	Early Entrants	Correct-for-age	Late Entrants	F; p	$\eta^2$
Gender (male %)	44.9%	50.5%	47.8%		
MAT	6.4±4.0	8.8±4.1	9.6±4.1	23.7; <.001	.025
CPT	66.0±25.3	77.8±25.9	82.6±24.5	17.2; <.001	.018
SNAP-4 Inattention	.72±.81	.55±.73	.36±.60	14.4; <.001	.018
SNAP-4 Hyperactivity	.59±.85	.40±.65	.31±.58	7.0; .001	.009
SDQ Total	13.0±4.7	12.2±4.1	11.7±3.4	4.4; .012	.006

MAT: Mathematics Achievement Test, CPT: Calculation Performance Test, SNAP-4: Strengths and Difficulties scores

**2- Gender:** Gender was a factor for mathematics ability, emotional and behavioral measures. Results indicated that girls had higher MAT  $F(1, 1904) = 7.1$ ;  $p=.008$ , SPM general ability  $F(1, 1904) = 12.0$ ;  $p=.001$ , and prosocial behaviors scores  $F(1, 1651) = 13.9$ ;  $p<.001$ . On the other hand, SDQ Total Problems score  $F(1, 1651) = 8.4$ ;  $p=.004$ , SNAP-IV Inattention ARI  $F(1, 1625) = 39.7$ ;  $p<.001$ , and Hyperactivity/Impulsivity ARI  $F(1, 1625) = 80.1$ ;  $p=.001$ , were higher in boys. All effect sizes were very small ( $\eta^2$  between 0.004 and 0.047).

**3- SES:** Results indicated that MAT  $F(1, 1904) = 9.9$ ;  $p=.002$ , CPT  $F(1, 1904) = 23.7$ ;  $p<.001$ , SPM general ability  $F(1, 1904) = 11.7$ ;  $p=.001$ , and prosocial behaviors  $F(1, 1651) = 13.9$ ;  $p<.001$ , were higher in higher SES group. On the other hand, SNAP-IV based attention problems  $F(1, 1625) = 15.2$ ;  $p<.001$ , and hyperactivity/impulsivity  $F(1, 1625) = 10.2$ ;  $p=.001$ , decreased with SES. All effect sizes were very small ( $\eta^2$  between 0.006 and 0.009).

**4- General Ability:** General ability had a significant and larger effect on all variables. MAT  $F(1, 1904) = 961.4$ ;  $p<.001$ ,  $\eta^2=.34$ , CPT  $F(1, 1904) = 551.0$ ;  $p<.001$ ,  $\eta^2=.23$ , and prosocial behaviors scores  $F(1, 1651) = 69.9$ ;  $p<.001$ ,  $\eta^2=.04$  increased with higher general ability, measured by Raven SPM. On the other hand, SDQ Total Problems score  $F(1, 1651) = 41.2$ ;  $p<.001$ ,  $\eta^2=.03$ , SNAP-IV Inattention ARI  $F(1, 1625) = 190.6$ ;  $p<.001$ ,  $\eta^2=.11$ , and Hyperactivity/Impulsivity ARI  $F(1, 1625) = 57.9$ ;  $p=.001$ ,  $\eta^2=.04$ , were higher in children with lower general ability.

**5- Kindergarten:** MAT  $F(1, 1583) = 29.6$ ;  $p<.001$ , CPT  $F(1, 1583) = 17.0$ ;  $p<.001$ , SPM general ability  $F(1, 1583) = 42.3$ ;  $p<.001$ , and prosocial behaviors  $F(1, 1353) = 10.0$ ;  $p=.002$ , were higher in children who attended Kindergarten. On the other hand, SNAP-IV based attention problems  $F(1, 1335) = 4.7$ ;  $p=.030$  were lower among these children. Effect sizes were between 0.004 and 0.026.

### Lowest Mathematics Ability and Prosocial Behaviors and Highest Problem Groups

**1- Age of school entry:** There was a “dose-response” effect between age of school entry and rates of having MAT (early: 27.0%; on-time: 13.0%; late: 9.9%) and CPT scores (early: 23.6%; on-time: 10.3%; late: 6.9%) lower than 10th percentile. Late entrants have lower rate of SDQ Prosocial Behaviors (early: 13.9%; on-time: 14.7%; late: 7.9%) score lower than 10th percentile. On the other hand, children who entered school earlier also had higher rates of having SNAP-IV Inattention (early: 21.3%; on-time: 12.1%; late: 8.0%) and Hyperactivity/Impulsivity ARI (early: 18.8%; on-time: 11.3%; late: 6.5%), and SDQ Total Problems (early: 16.0%; on-time: 13.5%; late: 8.3%) scores over 90th percentile when compared with other students.

**2- Gender:** Rate of boys was significantly higher than girls (14.9% vs 11.2%) for having MAT score and SDQ Prosocial Behaviors score (16.8% vs 9.1%) lower than 10th percentile. Boys also had higher rates of having SNAP-IV Inattention (17.2% vs 6.0%) and Hyperactivity/Impulsivity ARI (14.5% vs 6.3%), and SDQ Total Problems (14.7% vs 10.0%) scores over 90th percentile when compared with girls.

**3- SES:** Children from lower SES background had significantly higher rates of having SDQ Prosocial Behaviors score (17.4% vs 9.3%) lower than 10th percentile. These children also had higher rates of having SNAP-IV Inattention (13.5% vs 7.9%) and Hyperactivity/Impulsivity ARI (14.2% vs 9.3%), scores over 90th percentile when compared with children from higher SES.

**4- Kindergarten:** Children who did not attend to Kindergarten had higher rates of MAT (19.7% vs 9.4%), and CBT (15.4% vs 8.1%) lower than 10th percentile. These children also had higher rates of having SDQ Total Problems (14.1% vs 9.9%) scores over 90th percentile when compared with other children.

## MULTIVARIATE MODELS

### Mathematics Ability

Logistic regression analysis indicated that being in the lowest 10th percentile for MBT performance was associated with lower Raven SPM score (See Table 2 and 3 for details). On the other hand, being in the lowest 10th percentile for CPT score was associated with Raven SPM score and younger age of school entry.



**Table 2.** Results of the logistic regression analysis

	MAT					CPT				
	B	SE	Wald	p	OR (95%CI)	B	SE	Wald	P	OR (95%CI)
Gender	.17	.16	1.2	.28	1.2 (.87-1.6)	-.17	.17	.96	.33	.85 (.61-1.2)
Age of school entry	3.1			.22		5.1			.078	
Correct for age	-.40	.28	1.9	.16	67.2 (.39-1.2)	-.46	.29	2.4	.12	.63 (.35-1.1)
Late entry	-.56	.32	3.1	.08	.57 (.30-1.1)	-.77	.34	5.1	.02	.46 (.23-.91)
RSPM	-.14	.01	227.8	<.001	.87 (.85-.88)	-.14	.01	188.4	<.001	.87 (.85-.89)
SES	-.13	.16	.73	.39	.88 (.65-1.2)	-.15	.17	.79	.38	.886 (.62-1.2)

\*RSPM score, age of school onset group, socioeconomic status (SES), and gender were independent factors.

\*\*Outcomes were defined as being in the lowest 10th percentile for MAT, CPT, SDQ Prosocial Behaviors scores, or in the higher 10th percentile for SDQ Total Problems, SNAP-IV Hyperactivity/Impulsivity and Inattention ARI scores.

\*\*\*CI: Confidence Interval.

**Table 3.** Results of the logistic regression analysis (continuing from Table 2)

	SNAP-4 Inattention					SNAP-4 Hyperactivity					SDQ Total				
	B	SE	Wald	p	OR (95%CI)	B	SE	Wald	P	OR (95%CI)	B	SE	Wald	P	OR (95%CI)
Gender	.87	.18	22.6	<.001	2.3 (1.7-3.4)	1.2	.18	41.9	<.001	3.2 (2.2-4.5)	.36	.16	5.0	.025	1.4 (1.1-2.0)
Age of school entry	7.1			.029		7.6			.022		5.1			.078	
Correct for age	-.25	.32	.61	.43	.78 (.42-1.5)	-.53	.30	3.1	.08	.59 (.33-1.1)	.02	.34	.002	.96	1.0 (.53-2.0)
Late entry	-.82	.37	4.8	.03	.44 (.21-.92)	-.93	.35	7.2	.007	.40 (.20-.78)	-.45	.38	1.5	.23	.64 (.31-1.3)
RSPM	-.08	.01	71.8	<.001	.92 (.91-.94)	-.04	.01	22.5	<.001	.96 (.94-.98)	-.05	.01	37.8	<.001	.95 (.93-.97)
SES	-.49	.17	8.0	.005	.61 (.44-.86)	-.40	.16	6.2	.013	.67 (.49-.92)	.35	.16	4.8	.028	1.4 (1.0-1.9)

\*RSPM score, age of school onset group, socioeconomic status (SES), and gender were independent factors.

\*\*Outcomes were defined as being in the lowest 10th percentile for MAT, CPT, SDQ Prosocial Behaviors scores, or in the higher 10th percentile for SDQ Total Problems, SNAP-IV Hyperactivity/Impulsivity and Inattention ARI scores.

\*\*\*CI: Confidence Interval.

### Teacher Ratings

Being male, having lower Raven SPM score, lower SES and younger age of school entry were all associated with increased risk of being in the lowest 10th percentile for prosocial behaviors, and 90th percentile of SDQ Total Problems score, and SNAP-IV Inattentiveness and Hyperactivity/Impulsivity ARI. Overall, results suggested that, female students and students with better general ability had better prosocial skills and lower behavioral problems. Students with older age of school entry had less attention problems, hyperactivity and impulsivity.

### DISCUSSION

Our results indicated that there were several significant age related differences among students in the same grade. These differences included lower mathematics in the youngest group of children in third grade when compared with particularly oldest group of children in the same grade. Also youngest children showed lower general abilities and higher SNAP-IV hyperactivity/impulsivity, SNAP-IV inattention and SDQ emotional problems score as well as less prosocial behavior than oldest ones. This was consistent with a previous study which used parent and teacher rated SDQ to compare relative age effects and reported higher total problem scores in younger children (Goodman et al., 2003). Mean age difference between youngest and oldest group in the analysis was almost 16 months. Effect sizes of differences of means between the youngest and oldest age groups were largest for general ability and mathematics ability. Effect sizes for behavioral measures were smaller; largest difference was in SNAP-IV Inattention score. Smaller effect sizes were detected for SDQ Emotion Problems and Prosocial Behaviors, and SNAP-IV Hyperactivity/Impulsivity. Gender was another important factor, particularly for Hyperactivity/Impulsivity, Inattention and Conduct Problems. This was consistent with previous studies which reported higher prevalence of these problems in males (NICE ADHD Guideline, 2008). Effect size of gender on mathematics and general abilities were small.

Results suggested that, when compared with the oldest group, youngest students were less mature in cognitive and behavioral terms. Attention problems were associated with both general ability and mathematics ability ( $r = -.33$  and  $-.40$ , respectively). There were at least three possible explanations, which were not mutually exclusive, of this association. First, this association might be spurious. It can be speculated that, attention problems reported by teachers might be influenced by academic performance, which was lower in younger students, as indicated by worse mathematics ability. It has been reported that teacher reports may be based on comparison of children with their peers (Evans et al., 2010). Older, and more cognitively mature, children had higher mathematics ability and more prosocial behaviors. This may lead to a less favorable assessment of younger children by the teachers. In fact, it has been suggested that, children who were just under the cut-off age for school entry, who are older, had lower rate of ADHD and stimulant treatment (Evans et al., 2010). Second, children with lower general (lower SPM score) or mathematics ability might have more prominent attention problems and hyperactivity/impulsivity. It is well known that attention problems and hyperactivity/impulsivity is more common in subjects with learning problems (NICE ADHD Guideline, 2008). Third, subjects with attention problems might have lower academic performance, which has also been reported extensively (e.g. Wolraich et al., 2003).

Our results were consistent with previous studies. It has been shown that youngest children in a given grade had lower standardized test scores when compared with oldest students (Bedard & Dhuey, 2006), and children who enter school early had a higher risk of repeating grade (Elder & Lubotsky, 2009), and achieve less at school (Lien et al., 2005). Younger children also have a higher risk of receiving ADHD diagnosis (Elder & Lubotsky, 2009), being victim to bullying (Muhlenweg, 2010), and having learning disabilities (Dhuey & Lipscomb, 2008; Martin et al., 2004). In our sample, due to regulatory changes, age range was over one year in third grade. This was larger than most of the previous studies. Multiplier processes are important in amplifying differences. In fact, younger children in school were reported to have higher risk of psychopathology in adolescence, much later than school entry (Goodman et al., 2003). From an academic stand-point, older students' maturity advantage may increase their chance of selection for advanced curriculum groups or faster progress in a common curriculum, leading to accumulation of more skills (Bedard & Dhuey, 2006). Gender, socioeconomic status, race and other factors may also show multiplying effects. These processes may even be more evident in Turkey, where high-school and college entries depend on success in centrally administered examinations. In high-school exams, students are compared to their same grade peers, and there are huge quality differences between high-schools, which will further increase academic differences.

Limitations of the study included lack of a valid and reliable socioeconomic status indicator, lack of parent reports, assessment of only general and mathematics abilities. In Turkey, during the first four grades, teachers are responsible for a single classroom. We collected data at April, near end of the spring term. Therefore, we believe that teachers had ample opportunity to have valid and reliable opinions about their students. On the other hand, Elder reported that (2010), age of school entry affected teachers' perceptions of whether the child exhibits ADHD-related symptoms more strongly than parental perceptions. Therefore, parent reports might not show the age effects we reported.

We reported in this article data from a low-middle income country, which included academic and behavioral variables obtained from a single sample. Although academic variables have been reported more extensively in multinational studies, behavioral data are more sparse. Our data were largely consistent with previous studies from other countries, and extended the literature by showing evidence related to the differences in a single school grade. The data indicated that younger children in the same school grade showed lower general and mathematical ability and higher ADHD symptom scores based on teachers' evaluations.

## ACKNOWLEDGEMENT

This Project has been funded by the Scientific and Technological Research Council of Turkey (TUBITAK) under the grant number 214-S-069 in 2015.

## REFERENCES

- Bedard, K., & Dhuey, E. (2006). The persistence of early childhood maturity: international evidence of long-run age effects. *Quarterly Journal of Economics*, 121, 1437-1472. <https://doi.org/10.1093/qje/121.4.1437>
- Black, S. E., Devereux, P. J., & Salvanes, K. G. (2011). Too young to leave the nest? The effects of school starting age. *The Review of Economics and Statistics*, 93, 455-467. [https://doi.org/10.1162/REST\\_a\\_00081](https://doi.org/10.1162/REST_a_00081)
- Buntaine, R. L., & Costenbader, V. K. (1997). The effectiveness of a transitional prekindergarten program on later academic achievement. *Psychology in the Schools*, 34(1), 41-50. [https://doi.org/10.1002/\(SICI\)1520-6807\(199701\)34:1<41::AID-PITS5>3.0.CO;2-Y](https://doi.org/10.1002/(SICI)1520-6807(199701)34:1<41::AID-PITS5>3.0.CO;2-Y)

- Bussing, R., Fernandez, M., Harwood, M., Wei, H., Garvan, C. W., Eyberg, S. M., & Swanson, J. M. (2008). Parent and teacher SNAP-IV ratings of attention deficit hyperactivity disorder symptoms: psychometric properties and normative ratings from a school district sample. *Assessment, 15*, 317-328. <https://doi.org/10.1177/1073191107313888>
- De Meis, J. L., & Stearns, E. S. (1992). Relationship of school entrance age to academic and social performance. *The Journal of Educational Research, 86*(1), 20-27. <https://doi.org/10.1080/00220671.1992.9941823>
- De Vos, T. (1992). *Tempo-test rekenen (Number fact retrieval test)*. Nijmegen: Berkhout.
- Dhuey, E., & Lipscomb, S. (2008). What makes a leader? Relative age and high school leadership. *Economics of Education Review, 27*, 173-183. <https://doi.org/10.1016/j.econedurev.2006.08.005>
- Dobkin, C., & Ferreira, F. (2010). Do school entry laws affect educational attainment and labor market outcomes? *Economics of Education Review, 29*, 40-54. <https://doi.org/10.1016/j.econedurev.2009.04.003>
- Elder, T. E. (2010). The Importance of Relative Standards in ADHD Diagnoses: Evidence Based on Exact Birth Dates. *Journal of Health Economics, 29*, 641-656. <https://doi.org/10.1016/j.jhealeco.2010.06.003>
- Elder, T. E., & Lubotsky, D. H. (2009). Kindergarten Entrance Age and Children's Achievement: Impacts of State Policies, Family Background, and Peers. *Journal of Human Resources, 44*, 641-683. <https://doi.org/10.1353/jhr.2009.0015>
- Evans, W. M., Morrill, M. S., & Parente, S. T. (2010). Measuring inappropriate medical diagnosis and treatment in survey data: The case of ADHD among school-age children. *Journal of Health Economics, 29*, 657-673. <https://doi.org/10.1016/j.jhealeco.2010.07.005>
- Fidan, E. (2013). *İlkokul Öğrencileri İçin Matematik Dersi Sayılar Öğrenme Alanında Başarı Testi Geliştirilmesi [Mathematics Achievement Test for Primary School Students]* (Unpublished masters' thesis), Ankara Üniversitesi, Eğitim Bilimleri Enstitüsü.
- Gledhill, J., Ford, T., & Goodman, R. (2002). Does season of birth matter? The relationship between age within the school year (season of birth) and educational difficulties amongst a representative general population sample of children and adolescents (aged 5-15) in Great Britain. *Research in Education 68*, 41-47. <https://doi.org/10.7227/RIE.68.4>
- Goodman, R. (2001). Psychometric properties of the strengths and difficulties questionnaire (SDQ). *Journal of American Academy of Child and Adolescent Psychiatry, 40*, 1337-1345. <https://doi.org/10.1097/00004583-200111000-00015>
- Goodman, R., Gledhill, J., & Ford, T. (2003). Child psychiatric disorder and relative age within school year: cross sectional survey of large population sample. *British Medical Journal, 327*, 472-475. <https://doi.org/10.1136/bmj.327.7413.472>
- Güvenir, T., Özbek, A., Baykara, B., Arkar, H., Şentürk, B., & İncekaş, S. (2008). Psychometric Properties of The Turkish Version of The Strengths and Difficulties Questionnaire (SDQ). *Turkish Journal of Child Adolescent Mental Health, 15*, 65-74. Retrieved from <http://toad.edam.com.tr/sites/default/files/pdf/guclukler-anketi-toad.pdf>
- Jones, M. M., & Mandeville, G. K. (1990). The effect of age at school entry on reading achievement scores among South Carolina students. *Remedial and Special Education, 11*(2), 56-62. <https://doi.org/10.1177/074193259001100209>
- Lien, L., Tambs, K., Oppedal, B., Heyerdahl, S., & Bjertness, E. (2005). Is relatively young age within a school year a risk factor for mental health problems and poor school performance? A population-based cross-sectional study of adolescents in Oslo, Norway. *BMC Public Health 5*, 102. <https://doi.org/10.1186/1471-2458-5-102>
- Martin, A. J. (2009). Age appropriateness and motivation, engagement, and performance in high school: Effects of age within cohort, grade retention, and delayed school entry. *Journal of Educational Psychology, 101*(1), 101-114. <https://doi.org/10.1037/a0013100>
- Martin, R. P., Foels, P., Clanton, G., & Moon, K. (2004). Season of birth is related to child retention rates, achievement, and rate of diagnosis of specific ld. *Journal of Learning Disabilities, 37*, 309-317. <https://doi.org/10.1177/00222194040370040301>
- McNamara, J., Scissons, M., & Simonot, S. (2004). Should We "Redshirt" in Kindergarten? A Study of the Effect of Age on Kindergarteners' Reading Readiness. *Alberta Journal of Educational Research, 50*(2). Retrieved from <http://ajer.journalhosting.ucalgary.ca/index.php/ajer/article/view/449>
- Morrison, F. J., Alberts, D. M., & Griffith, E. M. (1997). Nature -nurture in the classroom: Entrance age, school readiness, and learning in children. *Developmental Psychology, 33*(2), 254. <http://dx.doi.org/10.1037/0012-1649.33.2.254>

- Mühlenweg, A. M. (2010). Young and innocent: International evidence on age effects within grades on victimization in elementary school. *Economics Letters*, *109*, 157-160. <https://doi.org/10.1016/j.econlet.2010.08.032>
- Mühlenweg, A., Blomeyer, D., Stichnoth, H., & Laucht, M. (2012). Effects of age at school entry (ASE) on the development of non-cognitive skills: Evidence from psychometric data. *Economics of Education Review*, *31*, 68-76. <https://doi.org/10.1016/j.econedurev.2012.02.004>
- National Institute for Health and Clinical Excellence. (2008). *Attention deficit hyperactivity disorder: diagnosis and management of ADHD in children, young people and adults*. (Clinical guideline 72). Retrieved from <http://www.nice.org.uk/CG72>
- Olkun, S., Can, D., & Yeşilpınar, M. (2013). Hesaplama Performansı Testi: Geçerlilik ve Güvenilirlik Çalışması. XII. Ulusal Sınıf Öğretmenliği Sempozyumu Bildiriler Kitabı. Aydın: Adnan Menderes Üniversitesi, 89-92. [Reliability and Validity Study of the Computational Performance Test]. In *Proceedings of the XII. National Classroom Teacher Education Symposium held in Aydın University: Aydın*.
- Raven, J. (2000). The Raven's progressive matrices: change and stability over culture and time. *Cognitive Psychology*, *41*, 1-48. <https://doi.org/10.1006/cogp.1999.0735>
- Thompson, A. H., Barnsley, R. H., & Battle, J. (2004). The relative age effect and the development of self-esteem. *Educational Research*, *46*(3), 313-320. <https://doi.org/10.1080/0013188042000277368>
- Wolraich, M., Lambert, E., Baumgaertel, A., Garcia-Tornel, S., Feurer, I. D., Bickman, L., & Doffing, M. A. (2003). Teachers' screening for attention deficit/hyperactivity disorder: comparing multinational samples on teacher ratings of ADHD. *Journal of Abnormal Child Psychology*, *31*, 445-455. <https://doi.org/10.1023/A:1023847719796>

<http://www.ejmste.com>

# Naïve Designers' Information Use during the Design Process in a Low-Resource Classroom

Nicolaas Blom<sup>1\*</sup>, Grietjie Haupt<sup>1</sup>, William Fraser<sup>1</sup>

<sup>1</sup> Department of Science, Mathematics and Technology Education, University of Pretoria, SOUTH AFRICA

Received 16 January 2018 • Revised 19 March 2018 • Accepted 9 April 2018

## ABSTRACT

Facilitating the design process in low-resource Technology classrooms has become increasingly challenging in the 21st century. This research focuses on the types of information sources used during learners' design processes. We examine the information sources that nine South African Grade 9 learners from a low-resource school used while they were engaged in a mechanical systems and control design task. They worked in groups of three to design a machine to lift logs from the ground onto a truck. We utilised a Think Aloud Protocol Study to collect concurrent verbal, visual and temporal data. The results indicate that Grade 9 design teams were predominantly engaged in problem solving activities by using mostly external sources of information during the early phases of the design process. If designing is the backbone methodology of Technology education, attention should be given to the information sources that learners use during designing.

**Keywords:** cognitive phases, design cognition, information sources, low-resource classrooms, technology education

## INTRODUCTION

During the early phases of the design process, learners have to engage in an iterative process of structuring and solving their design problem (Dym, Little & Orwin, 2014; Hay, 2017). The early phases of the design process are particularly challenging phases as this is when learners' level of uncertainty about how to proceed with their design process is higher (Jonassen, 2011). It is often difficult for learners to identify and define their design problem and to specify which directions to follow, due to the ill-structured nature of the design problems they deal with (Goel, 2014; Reed, 2016; Simon, 1973). Uncertainty is challenging for secondary school learners, who are considered to be untrained in focusing their attention (Gonçalves, Cardoso & Badke-Schaub, 2016; Pieper, 2013) and thus struggle to choose which direction to follow. To reduce their uncertainty, learners search for internal and external information with the aim of structuring and solving the design problem they are faced with (Song et al., 2016).

Although teachers provide learners with some information related to their design problems, it would be impossible for teachers to explore all possible aspects of each learner's design problem beforehand due to time constraints (Mettas & Norman, 2011). Furthermore, information given by teachers might be biased, i.e. have preferences toward specific solutions paths, which implies the prescribing of learners' design processes, which could potentially limit their creativity (McLellan & Nicholl, 2011). Recent studies in South Africa (Kola, 2017; Mathumbu, Rauscher & Braun, 2014) have also proven that technology teachers do not support the systematic development of learners' design processes, and provide limited facilitation of the cognitive processes during designing.

In light of the limitations of teacher-prepared information resources, other information sources including internet access, reference books and catalogues may help learners to structure and solve their design problems (Pieper, 2013). However, in South Africa, most classrooms and communities do not have sufficient information access. Of approximately 23 471 public schools in South Africa (DBE, 2018):

- 18 019 (70%) do not have stocked libraries; and



**Contribution of this paper to the literature**

- This paper suggests Extended Information Processing Theory (Haupt, 2018) as a novel theoretical framework through which secondary school learners' design cognition could be conceptualised.
- Current and future Technology teachers might improve their design process facilitation if they are aware of the relationship between learners' cognitive phases and available information sources during those phases.

- 15 896 (59%) do not have a computer centre.

The above-mentioned statistics imply that in the majority of Technology classrooms in South Africa, information is not easily accessible. It was our interest to conduct research in a low resource classroom, to investigate what types of information sources learners typically use during a mechanical systems and design task. For this study, we considered a low resource Technology classroom as a classroom that did not comply with the minimum resource requirements stipulated in the Technology Curriculum and Assessment Policy Statement (CAPS) (DBE, 2011). In **Table 1**, a list of requirements for Technology is provided, with which the case study did not comply.

**Table 1.** Resource requirements for Technology

1. Each learner must have an appropriate textbook	X	In our case study, the school did not provide learners with an appropriate textbook. Instead, only the teacher had a textbook.
2. Each learner must have a 72-page A4 workbook	√	Each learner had their own workbook.
3. Stationery including basic drawing instruments: pencil, eraser, ruler and set squares	X	The participants only had access to basic stationery items. However, they did not have access to drawing instruments such as set squares, and protractors.
4. A designated teaching venue with a Technology teacher	√	The school in which this study was conducted had their own Technology classroom.
5. Technology rooms must be secure, with doors that lock, and with burglar-proofing if possible. Enough cupboards should be available to store and lock away all resources	X	Although Technology classrooms were secured with a door and lock, the classrooms did not have any storing space or lockable cupboards available for storing tools, materials and projects.
6. It is the responsibility of the school to provide each learner with the minimum tools and material to meet the needs of the subject	X	The school did not provide learners with any tools or materials for their projects. Learners had to source their own materials.

In addition, the school was located in a low-socioeconomic area as indicated by the monthly income of households, unemployment rates and food insecurity, as found by Abbey (2008) and Naidoo (2011) regarding the area in which the research site was situated.

Despite the prescriptions in the Technology curriculum (DBE, 2011) to develop all South African learners' investigation skills in finding, analysing and synthesising information, few pedagogical guidelines exist to guide Technology teachers' facilitation of the early phases in low-resource classrooms. A majority of technology and engineering curricula stop short of providing teachers with any details related to learners' efforts to search for and use information (Pieper, 2013).

For this paper, we aimed to use an extended information processing framework through which we could identify the information sources that secondary school learners use during the early phases of the design process. Examining the information sources that learners search for is important for practical and theoretical reasons. First, this knowledge can assist curriculum developers to develop much-needed pedagogical guidelines to ensure that teachers are able to facilitate the early phases of the design process. Second, this knowledge might help curriculum developers and teachers to design learning environments that are conducive to complex thinking that mirrors that of expert designers (De Vries, 2016; Haupt, 2015; Oxman, 2001). Third, viewing the design cognition of secondary learners through extended information processing contributes to the limited theories of cognition specific to Technology education (Grubbs & Strimel, 2016; Petrina, 2010).

This investigation attempted to shed some light on what information learners searched for, which has implications for secondary Technology education, especially in low-resource contexts. Subsequently, this paper aims to address the following research question: What are the information sources that Grade 9 learners use during the early phases of the design process? Addressing this research question may help to guide teachers' decisions regarding the appropriateness of using information during learners' design tasks. It might also be beneficial to identify what information sources learners did not typically use in low-resource environments in order to design appropriate pedagogical interventions.



---

## LITERATURE REVIEW

### Designing as Problem Solving

The distinction between well-structured and ill-structured problems has been well documented in the problem solving literature (Csapó & Funke, 2017; Reed, 2016; Robertson, 2017), and has gained wide acceptance among researchers of design cognition. Designing as a cognitive activity is seen as a prime example of ill-structured problem solving (Goldschmidt & Rodgers, 2013; Grubbs & Strimel, 2016; Jonassen, 2011). Since the late 1960s, there have been many developments in understanding how designers solve ill-structured problems. The original work of Herbert Simon on ill-structured problem solving remains the dominant theoretical framework through which designing is conceptualised. Simon's work and its applicability to designing have also received many critiques. Subsequently, some of the original statements in Simon's work that deal with designing have since been qualified and refined (Dorst & Cross, 2001; Gero, 1998; Visser, 2009).

In his problem-solving approach to design, Simon (1973) distinguishes two cognitive phases in design problem solving, namely, problem structuring and problem solving. Problem structuring refers to the psychological process of forming a mental, subjective representation that reflects the perceived problem state and desired outcome (Simon, 1973). Typical activities in the design process related to problem structuring include defining the problem to be solved by understanding the users' needs and the design context; proposing and modifying design requirements, limitations and constraints; and formulating design goals and sub-goals (Björklund, 2013; Dym et al., 2014). Problem solving refers to the psychological process of 'searching' for possible solutions in a design problem solving space (Simon, 1973). Typical activities in the design process related to problem solving include proposing alternative design ideas, elaborating on possible design ideas, and choosing design ideas that could be further developed and detailed into a final design specification (Dym et al., 2014; Goel, 2014).

Goel (1995) further characterised designing as involving four cognitive phases: problem structuring, preliminary design, refinement, and detail specification. This paper is only concerned with the first two cognitive phases, which constitute the early phases of the design process. In our experience, Technology teachers are still uncomfortable with the uncertainties of the problem structuring and preliminary solving phases, and prefer to give learners a well-defined design brief (Mettas & Norman, 2011). Although a well-defined design brief might be beneficial for teachers for the purpose of managing learners' design processes, learners might be unaware of the need to structure their own design problem or consider the design context, which might prevent them from seeing their design project holistically.

Although the majority of professional design cognition studies have focused on the early phases of the design process (Dinar et al., 2015), several scholars maintain that the nature of the cognitive processes of professional and novice designers involved in the early phases remains unclear (Dorst & Cross, 2001; Jin & Benami, 2010; Kim & Ryu, 2014). When design issues in general are brought home to the specificity of their application in Technology education, it becomes clear that there are few studies that have empirically investigated the cognitive nature of Technology learners' design processes at both theoretical and empirical levels (Strimel & Grubbs, 2017; Wells et al., 2016). Recent findings in the literature focusing on the early phases reveal that the behaviours of Technology learners often differ from those of experts in key areas such as problem structuring, depth and breadth of the information sought, and time spent during individual cognitive phases (Atman et al., 2007; Kelley, Capobianco, & Kaluf, 2015; Mohedas, Daly, & Sienko, 2015). However, these studies have not yet explored what information sources naïve designers in secondary schools typically use during the early phases of the design processes. This paper speaks to this gap.

In their exposition of levels of design expertise, Lawson and Dorst (2009) have proposed that naïve designers should be considered as the first level of design expertise. According to them, designing can also be done by ordinary people, who have not yet engaged in formal design training. They characterise naïve design processes as a mimicry of existing solutions where naïve designers make their design choices based on limited previous knowledge and design experiences (Lawson & Dorst, 2009). Understanding how naïve designers engage in designing seems important because it marks the start of the process of developing design expertise. As such, this study focussed on the information sources used by naïve designers in a Technology classroom.

### Information Access and Use

For this paper, we viewed an information source as any fragment of information that has been interpreted by the designer and prompts a reaction to explore the problem or solution space (Cash & Gonçalves, 2017). In line with Extended Information Processing Theory, we could distinguish between two main types of information sources, including internal and external information sources. Internal sources include information that is located in the design task, for example, design requirements, constraints, limitations and intentions, or, stored in learners'

memory. External information sources are located externally in the Technology learning environment and include sources such as drawings, textbooks, 3D modelling materials, and pictorial information.

Currently, a limited amount of literature empirically shows how designers, in general and specific to Technology education, use information sources (Gonçalves et al., 2016; Mohedas et al., 2015; Restrepo, 2006). It is for this reason that we reviewed literature from design cognition in general, and specific to Technology education. In general, a design team's need to gather information during the early phases of the design process is fundamental to creating successful design solutions (Bursic & Atman, 1997; Cash & Gonçalves, 2017; Mohedas et al., 2015). Dym et al. (2014) suggest that information gathering is an essential process during the early phases of the design process. In design practice, information sources typically include literature on modern solutions, experts, design codes and regulations; competitive products; heuristics; models; handbooks; local laws and regulations; suppliers' component specifications; prior experiences; and feedback from clients. Designers use these information sources to structure and solve their design problems.

Professional designers spend a considerable amount of time gathering information during designing (Gonçalves, Cardoso & Badke-Schaub, 2014; Mohedas et al., 2015). During the design process, their need for several internal and external information sources changes over the course of their design task (Gonçalves et al., 2016). Designers typically search for different information sources to support their problem structuring efforts (Heisig, Caldwell, Grebici, & Clarkson, 2010), and their idea generation and development phases; (Gonçalves, Cardoso, & Badke-Schaub, 2013). Previous research has noted the value of information sources during the early phases of the design process, in particular, the positive effects of external information sources on idea generation (Gonçalves et al., 2016; Stables, 2010; Wu & Wang, 2015). In addition, research findings have also shown how information sources can deter designers from exploring other solutions as they become fixated (Dinar et al., 2015; McLellan & Nicholl, 2011; Nicholl & McLellan, 2005). Thus, information sources seem to have a substantial impact on designing, and are key to the exploration of the early phases of the design process (Cash & Gonçalves, 2017).

However, very few studies have zoomed in on how designers use information sources during problem structuring (Mohedas et al., 2015; Summers, Joshi, & Morkos, 2014), especially in secondary school technology classrooms (Pieper, 2013). Although some scholars are able to identify the cognitive phases involved during Technology learners' design processes (Kelley et al., 2015; Wells et al., 2016), they do not elaborate on the information sources that learners use during these cognitive phases. Gonçalves et al. (2016) suggests that the use of information sources during design activities supports the transition between problem structuring and problem solving. However, it is currently difficult to describe how information sources are influential during designing (Gonçalves et al., 2014), or how design situations build up from these information sources (Cash, Hicks, & Culley, 2015). One reason for this limitation might be as a result of the research methodology that researchers are utilising, namely, Think Aloud Protocol Studies (TAPS). A majority of the studies on learners' design cognition using TAPS methodology do not gather data revealing what external information sources learners use during designing. Ericsson and Simon (1993) attribute this limitation to the 'near' unmanageability of the large amounts of data that may be accumulated as a result. As such, the objective of this paper was to provide some evidence of what information Grade 9 learners typically accessed and used during the early phases of their design processes.

## THEORETICAL FRAMEWORK

This paper provides an alternative view of conventional Information Processing Theory that is currently emerging in the literature, namely extended information processing (Haupt, 2018). The Information Processing Theory of design problem solving has led to the belief that problem solving behaviour is dependent on a centralised internal processor of information localised in an individual designers' mind (Goel, 2014; Newell & Simon, 1972; Ullman, Dietterich & Stauffer, 1988). In this view, what learners think and what they do are seen as two separate activities. Furthermore, according to Information Processing Theories, the location of information solely resides in learners' memory, and therefore neglects to account for the role of the physical and social environment during the early phases of the design process.

In contrast to information processing theories, extended information processing recognises that designers' design task environment encompasses internal and external sources of information, irrespective of domain or level of expertise. Extended information processing theory developed as a subset of Situated Cognition (Robbins & Aydede, 2009) and Distributed cognition theories (Hutchins, 2014). Extended information processing draws from the Extended Mind (Clark, 2006, 2008; Clark & Chalmers, 1998), that reject exclusive internalist and externalist theories of cognition, in favour of an integrated model of cognition (Menary, 2007, 2010)

For the purpose of this study, an integrated model of design cognition was adopted. The authors furthermore believe that the design process is an integrated, continuous process in which designers, using internal and external information, develop a fit-for-purpose solution.

The benefit of using an extended information processing framework lies in the descriptive power it provides in describing the development of learners' design activity in conjunction with the information sources that learners use during problem structuring and solving. Cash and Gonçalves (2017) emphasise that there are limited theoretical frameworks describing the development of design methodology in conjunction with information sources. As such, an extended information processing framework provides a means to study how Technology learners use information sources during the early phases of the design process.

## METHODOLOGY

For this study, a pragmatic stance was adopted based on the integration of post-positivist and constructivist theories of design cognition (Petrina, Feng, & Kim, 2008). In order to identify what information sources the learners used, we followed a concurrent mixed methods approach (Creswell, 2014; Teddlie & Tashakkori, 2009) in which we utilised a case study research design (Yin, 2014). In order to collect data, we employed a Think Aloud Protocol Study (TAPS) methodology to study learners' design activities. Conducting a TAPS with the groups of participants allowed us to microscopically study *when* in the design process information sources were used. The authors studied three cases consisting of one group of two, and two groups of three Grade 9 Technology participants. The reason for using groups of participants rather than individual participants was based on maximising the verbal fluency among the participants during their TAPS. Welch & Lim (2000) also recommends studying groups of participants instead of individuals in order to create an environment that is conducive to thinking out loud.

### Context of the Study

The target population for this study comprised one high school Technology classroom situated in a low socio-economic public school. We gained access to the research site *via* a teacher who was known to us, since she had been a Technology student of ours, approximately nine years ago. The Grade 9 participants were selected purposefully on the basis of their involvement with Technology for approximately 3 years. We confirmed with the Technology teacher that the members of the target population had already been exposed to at least six different design projects throughout their school careers. The Technology teacher also informed us that the target population possessed the necessary design skills to complete their design tasks, including investigating, designing, making, evaluating, and communicating skills (DBE, 2011), as well as conceptual knowledge about mechanical systems and control (DBE, 2011).

Prior to participating in this study, the target group completed their Term 2 work, focusing on the mechanical systems and control content area. The term was sequenced over eight weeks, comprising 20 contact lessons. During the lessons in weeks 1-4, the target group was engaged in enabling tasks, which introduced them to a range of mechanical systems and control concepts, building on their Grade 8 work. These mechanical systems and control concepts included the following conceptual knowledge (DBE, 2011, p. 53):

- Hydraulic/pneumatic systems that use restrictors, one-way valves: hydraulic press/jack;
- Gear systems – spur, bevel, rack and pinion, worm;
- Mechanical control mechanisms – ratchet and pawl; cleats; bicycle brakes; disc brakes;
- Belt-drive systems with more than one stage;
- Pulley systems – fixed pulley, moveable pulley, and multiple pulleys (block and tackle); and
- Systems where mechanical, electrical or pneumatic systems are combined.

The teacher taught these concepts to the target group mainly from a textbook (Clitheroe et al., 2013) while they completed enabling tasks. During weeks 5-8, the target group completed a Practical Assessment Task (PAT) in groups of four with the aim of designing and making a 3D model of a hydraulic water pump, drawing on their prior knowledge of integrated mechanical systems and previous design skills. No tools and materials were provided by the school for the target group to make their 3D models of the water pump; the learners therefore had to source their own 'affordable and easily accessible' materials.

The participants from the target group had also been exposed to several external information sources during their previous design projects. These external sources included: a workbook; Learning and Teaching Support Material (LTSM) such as worksheets, experiments and posters on the walls of the class and case studies. It should, however, be noted that the target population for this study did not have their own textbooks. Only the teacher had a Technology textbook, which was used to guide teaching and learning. The teacher copied important information for the learners and summarised the textbook. This was then given to the learners to paste in their workbooks.

## Sampling

For this study, we relied on convenience sampling to select one participating school, based on their geographical proximity in Gauteng, Pretoria and their availability to participate. We also used purposive sampling to select eight participants (three groups of learners from different Grade 9 classes). At our request, the teacher from the secondary school selected nine, verbally fluent candidates, of which one declined to participate at the last minute. In South Africa, where there are 11 official languages, but high school education is entirely conducted in English, fluency in English was a serious consideration to ensure the depth and richness of data. Such fluency often coincides with a high achievement in the demographics of secondary schooling (Trudell, 2007). Coincidentally, the sampling based on this criterion yielded nine female participants. Further sampling criteria that the authors gave to the teacher for participant selection included, the ability to work together as a group, and above-average design capability. The authors derived these criteria from the CAPS document for Technology as examples of exemplary design capability behaviour (DBE, 2011, p. 44). All the participants signed informed assent forms in line with the ethical clearance protocols of our institution. They had also been informed that they were at liberty to withdraw from the recordings at any time.

## Data Collection Strategies

We interviewed the teacher to access information regarding the work already covered, after which we collected data during the course of two consecutive afternoons. We used a Think Aloud Protocol Study (TAPS) to collect evidence of the participants' use of internal and external information sources (Ericsson & Simon, 1993). As such, we were able to concurrently collect a verbal protocol of the participants' utterances; and visual evidence of the participants' external representations, i.e. sketches, writings, 3D modelling, and temporal data of the participants' design task performance. The TAPS method requires the participants of a study to talk out loud as they are performing a given task while being video recorded (Ericsson & Simon, 1993; Kelley et al., 2015)

The authors were able to elicit the design cognition behaviour of each group of participants by providing them with a design task (see [Appendix A](#)) that we adapted from a prescribed textbook suggested by the DBE (Johnstone et al., 2013). The authors adapted the design task on the basis of the participants' work from the previous term, focusing on concepts of mechanical systems and control. The participants did not have access to this design task prior to the study. In the given design task, the groups of participants were required to design a model of a lifting machine that could pick up logs from the ground and transfer them onto a transport truck. The participants were also instructed before the study to bring their workbooks to class, which contained their previous term's work. This had the potential to stimulate idea generation and enhance their access to external information sources.

The design task played a central role in eliciting the participants' information access and use during their design processes. We collected and analysed primarily qualitative data, which included concurrent verbal and visual data. The verbal data was collected sequentially from the start of the participants' protocols, while the visual data consisted of external representations that the participants produced in the form of sketches, 3D models and writings. Quantitative data was collected in the form of temporal instances of information access and use behaviour.

## Data Analysis

The primary unit of analysis for this study was the verbal utterances made by the participants, which were clustered into modules that we could interpret as cognitive actions. A module was defined as "a complete portion of text uttered by a participant, without interruption from the other participants" (Welch, 1999, p. 24).

The data analysis and interpretation was guided by a multi-phase coding scheme derived from Ullman et al. (1988) and (Goel, 1995) that we applied to all modules. The result of this process was a microscopic analysis of the design process of each group of participants, which revealed when and where information sources were used during the early phases of the design process. The protocol analysis allowed the researchers to identify instances where the participants were engaged in problem structuring and problem solving. Furthermore, the researchers were also able to identify instances in which the participants used internal and external information sources.

## Quality Measures

In order to ensure the consistency and repeatability of the coding procedures, the researchers utilised an inter-coder reliability technique. Two researchers who were researching the early phases of the design process with similar coding schemes independently classified ten sample groups of verbal utterances according to the coding scheme for this study. The consistency of the agreement between the two researchers was determined by using the following formula:

$$\text{Inter-rater reliability} = \frac{\text{Number of agreements}}{\text{Number of possible agreements}} \times 100 = \frac{9}{10} = 90\%$$

A review of the two researchers' classification revealed that the small disagreement noted above (10%) could be attributed to the fact that the problem structuring and problem solving cognitive phases are not always clearly distinguishable (Goel, 1995; Restrepo & Christiaans, 2004). Stemler (2004) suggests that values ranging from 75% to 100% demonstrate a satisfactory level of credibility when determining inter-rater reliability based on the percentage of absolute agreement. Establishing an agreement between two sets of codings seemed to have resulted in credible inferences.

### Limitations

Firstly, the small purposive sample does not allow for generalised statements to be made about the design process of all Grade 9 naïve designers. The selected groups of participants were of secondary importance, as our primary aim was to gain insight into the *types* of information sources naïve designers use to structure and solve their design problems (Yin, 2014). However, the possibility of certain tendencies being transferable to similar Technology classrooms does exist, as other low resource Technology classrooms might display a context and characteristics similar to the one described in detail in this article. Secondly, the sample that was selected by the Technology teacher only comprised female Grade 9 participants. The sample selection criteria focused primarily on the participants' ability to communicate effectively, but also on their ability to work together effectively as a group, and above average design capabilities. The sample criteria did not allow the teacher to discriminate between genders. Future studies could include stratified sampling criteria, which might include an equal distribution of male and female participants. Thirdly, the TAPS methodology that we used for collecting data was limited because it could not provide us with direct access to the internal information sources that the participants used during their design tasks. In order to compensate for this limitation, we collected multiple forms of external representations, including the participants' verbal utterances and their concurrent gesturing, sketching, writing, and 3D models. These multiple data sources allowed us to infer what internal information sources the participants were using. The multiple data sources also complemented each other, thereby validating the inferences that we made about the internal information sources that the participants used. Fourthly, the number of participants, uneven by accident, not design because of the withdrawal of one participant, might have influenced the frequency counts of cognitive phases and information sources. However, since the focus of this study was on the types of information sources used to structure and solve a design problem, this was not deemed to be problematic in terms of the reliability of the results.

### RESULTS

**Table 2** indicates that the participants in all three groups engaged predominantly in problem solving cognitive phases, as compared to problem structuring phases during their design processes. Reviewing the percentages of all three groups, problem structuring utterances constituted less than 20% of the verbal utterances of each group's design process. There did not seem to be an aberration in this regard in the group that only had two members.

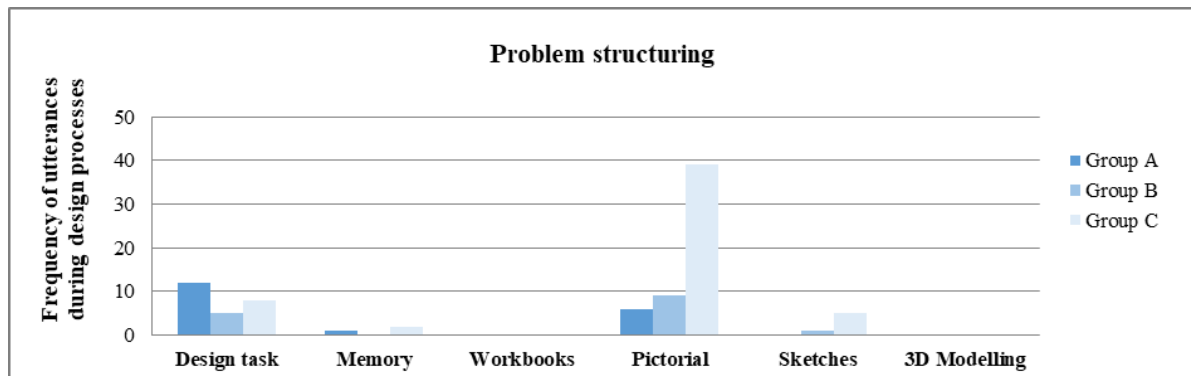
**Table 2.** Frequency and percentage of utterances in each cognitive phase made by the groups of participants

		Frequency	Total utterances	Percentage
<b>Group A</b>	Problem structuring	44	260	<b>16.9</b>
	Problem solving	216		<b>83.1</b>
<b>Group B</b>	Problem structuring	10	227	<b>4.4</b>
	Problem solving	216		<b>95.1</b>
<b>Group C</b>	Problem structuring	44	326	<b>13.5</b>
	Problem solving	283		<b>86.8</b>

More than 80% of the total utterances in each group of participants focused on problem solving, indicating that the majority of the participants' design processes were dominated by design problem solving activities. The findings in design cognition suggest that expert designers spend the majority of their time focusing on understanding design problems, whereas novice designers tend to spend the majority of their time on developing solutions even when they have not yet understood their design problem (Kelley et al., 2015; Lawson & Dorst, 2009; Welch, 1999). This finding implies that if Technology teachers want their learners to think more like expert designers, they need to facilitate learners to think about and represent their design problems more often.

In order to establish what sources each group of participants accessed and used during their cognitive phases, we counted the occurrences of the cognitive phases that each group of participants exhibited, as well as the information sources that they used. As such, we were able to describe what sources of information each group of participants used during problem structuring and solving respectively. Each of the groups' problem structuring

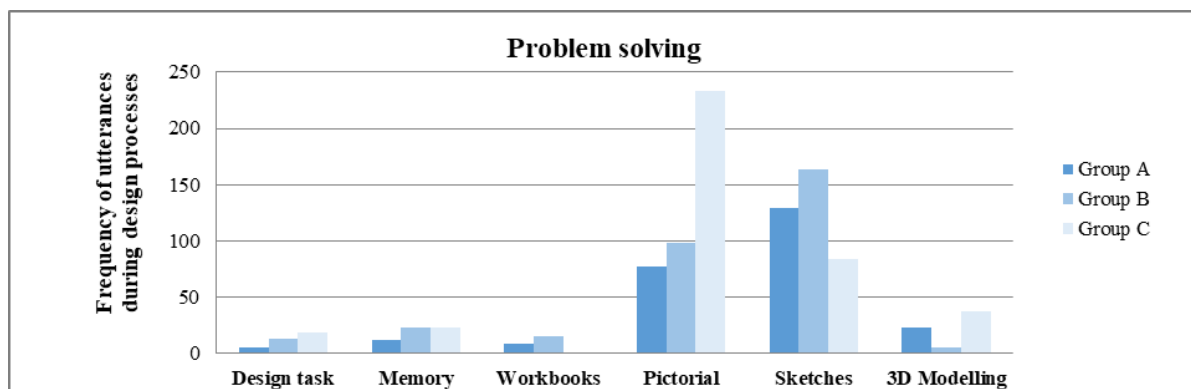
and solving cognitive phases are visualised using bar graphs in **Figures 1** and **2** to show the most prominent patterns of information sources accessed and used.



**Figure 1.** Frequencies of information use during problem structuring

In **Figure 1**, the data patterns reveal that the participants in this study predominantly used the design task and pictorial information during their problem structuring phases. Therefore, it seems as if the participants found information about the design problem and pictorial information more useful than their workbooks, sketches and 3D modelling materials to structure their design problems. This implies that these learners did not make their own representations of the design problem and relied predominantly on the information given in the design task, and pictorial information.

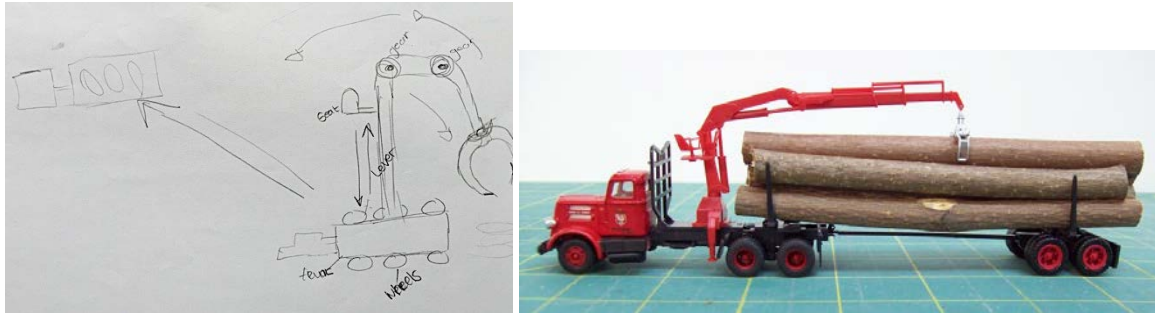
**Figure 1** also indicates that the participants rarely accessed or used their workbooks or 3D modelling materials for problem structuring. This might have important implications for curriculum planning in Technology, since Technology textbooks do not necessarily contain sufficient information to allow participants to structure their design problems. If low-resource classrooms are instructed to solve design problems in their textbooks, then sufficient information should be made available to understand the context of the problem and the people involved, which will lead learners to formulate appropriate design objectives and constraints.



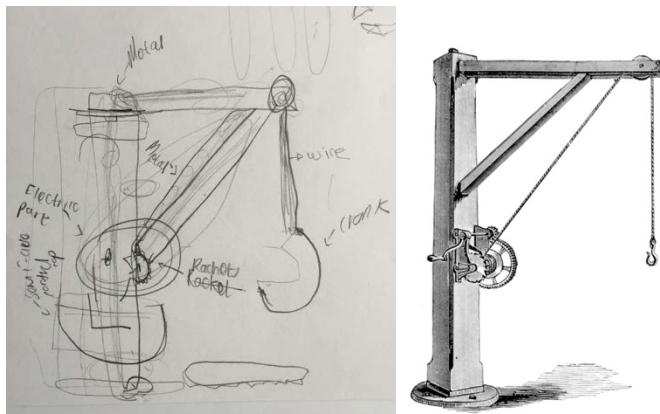
**Figure 2.** Frequencies of information use during problem solving

**Figure 2** indicates that all three groups predominantly accessed and used external pictorial information and their sketches as information sources during problem solving. Therefore, the participants in this study relied predominantly on external sources of information to solve their design problem. Furthermore, **Figure 2** also shows that the participants paid less attention to information sources, including prior knowledge, their workbooks and 3D modelling materials. Previous findings have shown that novice designers tend to engage in external information driven design (Kruger & Cross, 2006) because they do not have the necessary prior experience in designing. When comparing the participants' proposed design ideas, we could see how the participants copied their ideas from existing solutions. **Figures 3-5** reveal the similarities between external pictorial information and the groups of participants' proposed design ideas.

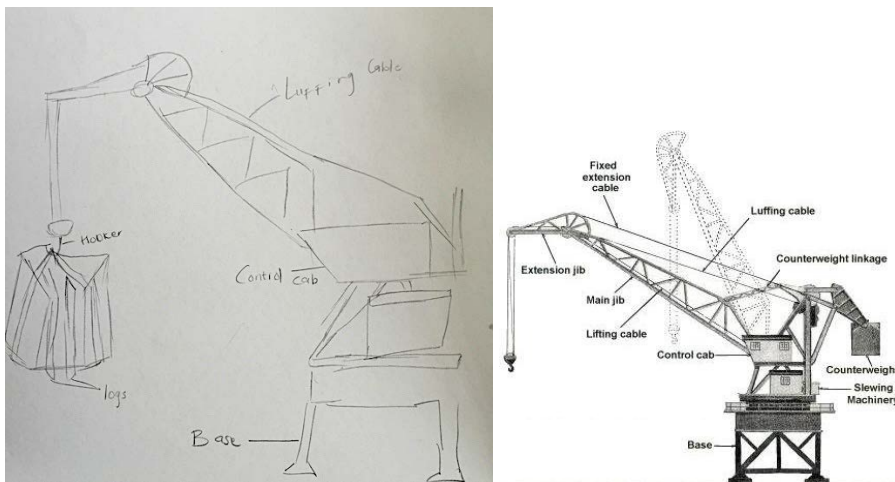




**Figure 3.** Group A's proposed design idea and the electrically powered crane on a truck (Figure 25 in Appendix A) on which it was based



**Figure 4.** Group B's proposed design idea and the gear and crank system (Figure 14 in Appendix A) on which it was based



**Figure 5.** Group C's proposed design idea and the electrically powered crane (Figure 22 in Appendix A) on which it was based

In Figures 3-5 the similarity between the participants' final design ideas and the pictorial information on which their ideas were based, is illustrated. From an extended information processing view, it seems as if the pictures (see Appendix A) afforded the participants the information which they used to propose their design ideas. Although it might seem as if the participants just copied these ideas from pictures, extensive clarification and elaboration processes were evident in the protocols, but did not form part of the focus for this paper.

### Distribution of Cognitive Phases and Information Sources

Hmelo-Silver, Chernobilsky and Jordan (2008) note that the frequencies of design actions provide only one view of learners' design processes, but do not provide context or information on particular design actions. In order to examine how the different information sources related to the participants' cognitive phases, we created three

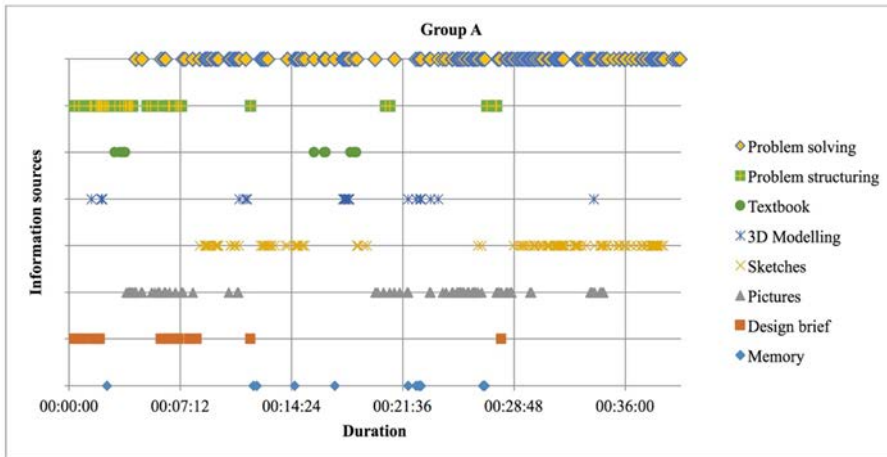


Figure 6. Distribution of Group A's cognitive phases and information sources

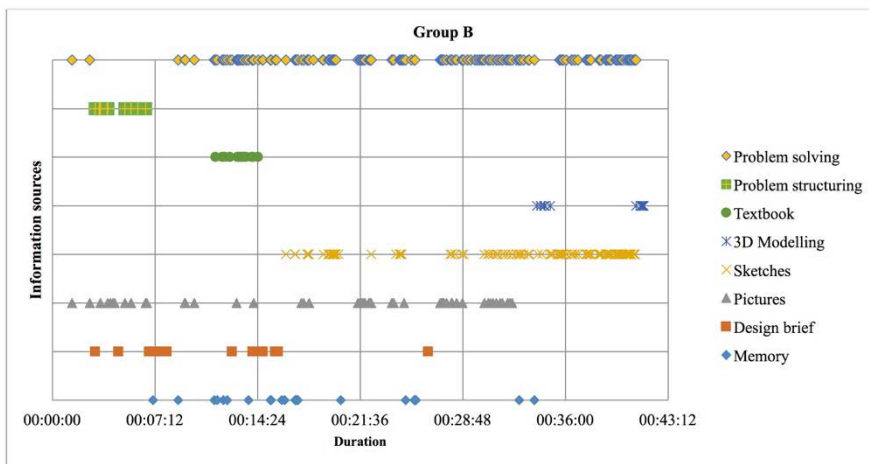


Figure 7. Distribution of Group B's cognitive phases and information sources

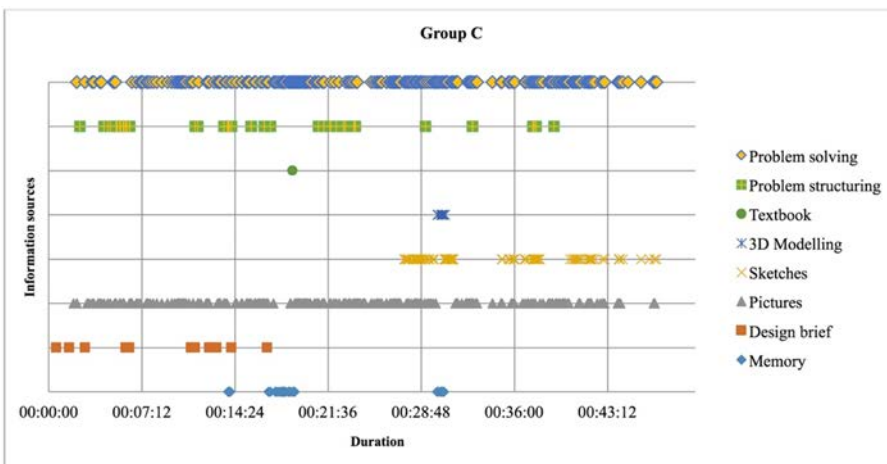


Figure 8. Distribution of Group C's cognitive phases and information sources

CORDTRA (Chronologically-Ordered Representation of Discourse and Tool Related Activity) diagrams to represent each participating group's design processes (see Figures 6-8).

In Figures 6-8, Group A and B had different patterns in the distribution of their problem structuring cognitive phases. While both Groups A and B primarily engaged in problem structuring at the beginning of their design

processes, Group C continuously engaged in problem structuring during their design process. All three groups engaged in problem-solving cognitive phases throughout their design processes.

When focusing on the design task and the cognitive phases, it seems as if the design task was instrumental in facilitating all three groups to engage in problem structuring at the beginning of the design process. It appears, however, that the design brief was not considered throughout the participants' design processes, albeit for a few outliers. In advanced teaching methods for the Technology classroom, Petrina (2007) notes that the role of the design brief is to focus the efforts of learners on the design task, and is not a single-use document, i.e. the design brief should be used throughout the design process to ensure that the solutions that are generated and developed by designers actually fit the identified design problem. As such, it seems as if the participants only focused on the problem that they needed to address in the beginning of their design process without referring back to it during the middle or end of the design process. This finding confirms previous studies on Technology learners have evidenced how learners neglect to consider the problem they are addressing throughout their design process (Dixon & Johnson, 2012; Hill & Anning, 2001; Kimbell & Stables, 2008).

When considering the distribution of pictorial information during the design process, it seems that all three groups used pictures throughout the problem structuring and solving phases. Previous studies on novice designers have shown consistently that novice designers prefer to use pictorial information as sources of inspiration during designing (Cash & Gonçalves, 2017; Gonçalves et al., 2016; Gonçalves, Cardoso & Badke-Schaub, 2014). As seen in **Figures 3-5**, when providing the participants with pictorial information regarding existing solutions, the participants copied the ideas. However, providing pictures of existing solutions might have stifled the participants' own creative behaviours (McLellan & Nicholl, 2011).

## DISCUSSION

The first finding of this study indicated that the participants predominantly engaged in problem solving rather than problem structuring cognitive phases. This was expected since naïve designers do not have sufficient prior experience and knowledge to understand their design problem context or to recognise the complexity of the design issues to be addressed. Findings focusing on the early phases of designing indicate that the behaviour of Technology learners often differs from that of expert designers in terms of time spent on problem structuring and evaluation (Atman et al., 2007; Kelley et al., 2015; Mohedas et al., 2015).

Another finding revealed that the participants rarely accessed information from their memory to structure or solve their design problem. One reason for this could be the participants' lack of information and exposure to the problem context of the design task. It is unlikely that the participants understood the problem context, because they had limited prior knowledge and experience with such mechanical design problems. Furthermore, prior research in a South African context shows that teachers do not attempt to contextualise textbook content for learners (Ramaligela, Gaigher & Hattingh, 2014), a fact which may lie at the basis of this finding. Although the participants were engaged in 10 weeks of instruction on mechanical systems and control, they struggled to transfer the knowledge and skills acquired in 10 weeks of instruction to the given design task. Extended information processing theory, then, allowed us to study how the participants compensated for their lack of internally stored knowledge and experience by using information from external information sources.

By relying on an extended information processing view on the data we found that pictorial information and sketches were the most consistently used. This made sense, because the pictures provided information about the design context and existing solutions. Furthermore, pictorial information may be the only way in which the participants from a low-resource school could have access to the context of the design problem and existing solutions. Unfortunately, there are limited empirical findings on the way in which naïve designers actually use pictorial information during the design process (Gonçalves et al., 2016; Gonçalves et al., 2014).

The participants' use of sketches could potentially be explained by Dorst and Lawson's (2009) levels of design expertise. While the participants used sketching extensively, their sketching was mainly based on understanding and copying from existing solutions which they perceived in pictorial information. Since the participants of this study did not have sufficient prior knowledge or experience in design contexts featuring mechanical systems, this behaviour was predictable. Future studies might gain insight into how naïve designers transform existing ideas from pictorial information into novel design solutions.

## IMPLICATIONS

In this study, the participants tended to spend more time solving as opposed to structuring their design problem. Teachers might want to consider how to facilitate between problem structuring and problem solving, as is done by expert designers, when they see that learners do not have sufficient understanding of their design problem. By asking hinge-point questions (William, 2011) or engaging in Socratic questioning throughout the

design process, teachers can easily gauge whether learners understand fundamental design issues and concepts to be addressed during their PAT. Since naïve designers do not yet possess prior knowledge or experience to solve design problems on their own, it is necessary for teachers to facilitate ways of thinking and knowing mirroring expert designing.

If learners do not readily access and use information from their memory to structure or solve their design problem, it may mean that the content taught during enabling tasks, prior to the PAT, was not contextualised in a way that seems useful. Prior research findings that show that some South African teachers do not contextualise learning content for learners (Ramaligela et al., 2014), as well as the fact that expert designers predominantly rely on domain specific knowledge stored in their memory, indicate that teachers should model how previously learned concepts in enabling tasks are necessary for success in the PATs. Since the mechanical systems learning content prescribed by the Technology curriculum is devoid of context, and mainly based on physics, it remains the responsibility of the Technology teacher to contextualise learning content.

If learners are not able to access and use information located in their memory, they will search for information in the external environment. This was seen in this study in the participants' predominant use of pictorial information and sketches to solve their design problems. Since naïve designers do not yet have the internally stored prior knowledge and experience, it is imperative that effective external sources of information are suggested, either by curriculum developers, textbook writers or teachers for use during learners' PATs. However, simply providing examples of existing solutions enhances participants' copying of ideas. Therefore, further research may show how advanced beginner, competent and proficient designers (Lawson & Dorst, 2009) interact with external information, and so enhance understanding of how novel ideas emerge.

## CONCLUSION

The purpose of this paper was not to generalise its findings, but to identify the internal and external information sources that Grade 9 Technology learners from a low-resource school used during a mechanical systems and control design task. The Extended Information Processing Theory guided us to identify what internal and external information sources the participants in this case study used during problem structuring and problem solving. Describing each participating group's design process from an extended information processing viewpoint allow opportunities for demonstrating how design thinking is a rational activity in which information sources are purposefully and intentionally used for designing. This implies that teachers can effectively support learners' design processes by showing and manipulating existing information sources, or by reminding learners of prior knowledge to structure and solve their design problems. Finding empirical evidence regarding what information sources naïve designers use during design tasks might contribute to better facilitation of the design process in Technology classrooms. If we want Technology learners to develop higher-order design cognition, we should encourage current and future teachers to design and provide meaningful learning environments in which learners are exposed to various information sources during their design tasks. During learners' design tasks, teachers should scaffold learners' design processes by introducing or reminding learners of valuable information on which to base their design decisions. Failing to scaffold learners' design processes with information sources might result in learning failures characterised by common and predictable design solutions due to a lack of critical thinking. As such, learners should be guided to make informed design decisions based on appropriate contextual, theoretical, and practical information in order to prevent superficial design solutions.

## ACKNOWLEDGEMENTS

The financial support of the National Research Foundation (NRF) of South Africa is hereby acknowledged and appreciated. Opinions expressed and conclusions arrived at are those of the authors and may not necessarily be attributed to the above mentioned institutions.

## REFERENCES

- Abbey, S. K. (2008). *Modelling socio-economic dynamics in a working-class desegregation area in post-industrial, post-apartheid South Africa – the case of Danville-Elandsport* (Doctoral thesis), University of Pretoria, Pretoria.
- Atman, C., Adams, R., Mosborg, S., Cardella, M., Turns, J., & Saleem, J. (2007). Engineering design processes: a comparison of students and expert practitioners. *Journal of Engineering Education*, 96. <https://doi.org/10.1002/j.2168-9830.2007.tb00945.x>
- Björklund, T. A. (2013). Initial mental representations of design problems: Differences between experts and novices. *Design Studies*, 34(2), 135–160. Retrieved from <http://doi.org/10.1016/j.destud.2012.08.005>



- Bursic, K. M., & Atman, C. J. (1997). Information gathering: a critical step for quality in the design process. *The Quality Management Journal*, 4(4), 60–75. <https://doi.org/10.1080/10686967.1998.11919148>
- Cash, P., & Gonçalves, M. (2017). Information-triggered Co-evolution: A Combined Process Perspective. In B.T. Christensen, L.J. Ball & K. Halskov (Eds.), *Analysing Design Thinking: Studies of Cross-Cultural Co-Creation* (pp. 501 – 520). London: CRC Press.
- Cash, P., Hicks, B., & Culley, S. (2015). Activity Theory as a means for multi-scale analysis of the engineering design process: A protocol study of design in practice. *Design Studies*, 38, 1–32. Retrieved from <https://doi.org/10.1016/j.destud.2015.02.001>
- Clark, A. (2006). Soft Selves and Ecological Control. In D. Spurrett, D. Ross, H. Kincaid & L. Stephens (Eds.), *Distributed Cognition and the Will* (pp. 101 – 122). Cambridge MA: The MIT Press.
- Clark, A. (2008). *Supersizing the Mind: Embodiment, Action, and Cognitive Extension*. New York: Oxford University Press.
- Clark, A., & Chalmers, D. (1998). The extended mind. *Analysis*, 58, 10–23. <https://doi.org/10.1093/analys/58.1.7>
- Clitheroe, F., Goosen, A., Kathan, V., Mlambo, T., Roebert, M., Sargeant, I., & Walstra, K. (2013). *Platinum Technology*. Cape Town: Maskew Miller Longman.
- Creswell, J. W. (2014). *Research Design: Qualitative, Quantitative and Mixed Methods Approaches*. Lincoln, USA: SAGE Publications.
- Csapó, B., & Funke, J. (2017). The development and assessment of problem solving in 21st-century schools. In B. Csapó, & J. Funke (Eds.), *The nature of problem solving: Using research to inspire 21st century learning*. <https://doi.org/10.1787/9789264273955-en>
- DBE. (2011). *Curriculum and Assessment Policy Statement. Senior Phase: Technology*. Republic of South Africa: South African Department of Basic Education.
- DBE. (2018). *National Education Infrastructure Management System*. Retrieved from <https://www.education.gov.za/Portals/0/Documents/Reports/NEIMSReport20172018.pdf?ver=2018-01-30-120305-787>
- De Vries, M. (2016). *Teaching about Technology. An Introduction to the Philosophy of Technology for Non-philosophers*. Dordrecht: Springer.
- Dinar, M., Shah, J., Cagan, J., Leifer, L., Linsey, J., Woodruff, G., & Vargas Hernandez, N. (2015). Empirical Studies of Designer Thinking: Past, Present, and Future. *Journal of Mechanical Design*, 137, 1–13. Retrieved from <https://doi.org/10.1115/1.4029025>
- Dixon, R. A., & Johnson, S. D. (2012). The Use of Executive Control Processes in Engineering Design by Engineering Students and Professional Engineers. *Journal of Technology Education*, 24(1), 73–89. Retrieved from <http://scholar.lib.vt.edu/ejournals/JTE/v24n1/dixon2.html>
- Dorst, K., & Cross, N. (2001). Creativity in the design process: co-evolution of problem–solution. *Design Studies*, 22(5), 425–437. [https://doi.org/10.1016/S0142-694X\(01\)00009-6](https://doi.org/10.1016/S0142-694X(01)00009-6)
- Dym, C. L., Little, P., & Orwin, E. J. (2014). *Engineering Design: A Project based approach* (4th ed.). United States of America: John Wiley & Sons.
- Ericsson, K. A., & Simon, H. A. (1993). *Protocol analysis: Verbal reports as Data* (2nd ed.). Cambridge, MA: MIT Press.
- Gero, J. (1998). Towards a Model of Designing Which Includes its Situatedness. In H. Grabowski, S. Rude, & G. Grein (Eds.), *Universal Design Theory* (pp. 47–56). Aachen: Shaker Verlag.
- Goel, V. (1995). *Sketches of Thought*. Cambridge, MA: MIT Press.
- Goel, V. (2014). Creative brains: designing in the real world. *Frontiers in Human Neuroscience*, 8(April), 241. Retrieved from <https://doi.org/10.3389/fnhum.2014.00241>
- Goldschmidt, G., & Rodgers, P. A. (2013). The design thinking approaches of three different groups of designers based on self-reports. *Design Studies*, 34(4), 454–471. <https://doi.org/10.1016/j.destud.2013.01.004>
- Gonçalves, M., Cardoso, C., & Badke-Schaub, P. (2013). Inspiration peak: exploring the semantic distance between design problem and textual inspirational stimuli. *International Journal of Design Creativity and Innovation*, 1(4), 215–232. <https://doi.org/10.1080/21650349.2013.799309>
- Gonçalves, M., Cardoso, C., & Badke-Schaub, P. (2014). What inspires designers? Preferences on inspirational approaches during idea generation. *Design Studies*, 35(1), 29–53. <https://doi.org/http://dx.doi.org/10.1016/j.destud.2013.09.001>
- Gonçalves, M., Cardoso, C., & Badke-Schaub, P. (2016). Inspiration choices that matter: the selection of external stimuli during ideation. *Design Science*, 2. <https://doi.org/10.1017/dsj.2016.10>

- Grubbs, M., & Strimel, G. (2016). Cognitive Research: Transferring Theories and Findings to K-12 Engineering Educational Practice. In the *American Society for Engineering Education 103rd Annual Conference and Exposition*. New Orleans, LA: American Society for Engineering Education.
- Haupt, G. (2015). Learning from experts: fostering extended thinking in the early phases of the design process. *International Journal of Technology and Design Education*, 25(4), 483–520. <http://doi.org/10.1007/s10798-014-9295-7>
- Haupt, G. (2018). Hierarchical thinking: a cognitive tool for guiding coherent decision making in design problem solving. *International Journal of Technology and Design Education*, 28(1), 207–237. <http://doi.org/10.1007/s10798-016-9381-0>
- Hay, L., Duffy, A., McTeague, C., Pidgeon, L., Vuletic, T., & Grealy, M. (2017). A systematic review of protocol studies on conceptual design cognition: Design as search and exploration. *Design Science*, 3, 1–36. <http://doi.org/10.1017/dsj.2017.11>
- Heisig, P., Caldwell, N. H. M., Grebici, K., & Clarkson, P. J. (2010). Exploring knowledge and information needs in engineering from the past and for the future – results from a survey. *Design Studies*, 31(5), 499–532. <https://doi.org/10.1016/j.DESTUD.2010.05.001>
- Hill, A. M., & Anning, A. (2001). Comparisons and Contrasts between Elementary/Primary School Situated Design and Workplace Design in Canada and England. *International Journal of Technology and Design Education*, 11(2), 111–136.
- Hmelo-Silver, C., Chernobilsky, E., & Jordan, R. (2008). Understanding collaborative learning processes in new learning environments. *Instructional Science*. Springer. <https://doi.org/10.2307/23372648>
- Hutchins, E. (2014). The cultural ecosystem of human cognition. *Philosophical Psychology*, 27(1), 34–49. <https://doi.org/10.1080/09515089.2013.830548>
- Jin, Y., & Benami, O. (2010). Creative patterns and stimulation in conceptual design. *Artificial Intelligence for Engineering Design, Analysis and Manufacturing*, 24(2), 191. <https://doi.org/10.1017/S0890060410000053>
- Johnstone, H., Mitchley, A., Schreuder, B., Sherwood, R., Snyman, E., & Ter-Morshuizen, K. (2013). *Technology Today Gr. 9*. South Africa: Maskew Miller Longman.
- Jonassen, D. H. (2011). *Design problems for secondary students*. Retrieved from [http://digitalcommons.usu.edu/ncete\\_publications/164](http://digitalcommons.usu.edu/ncete_publications/164)
- Kelley, T., Capobianco, B., & Kaluf, K. (2015). Concurrent think-aloud protocols to assess elementary design students. *International Journal of Technology and Design Education*, 25(4), 521–540. <http://doi.org/10.1007/s10798-014-9291-y>
- Kim, J., & Ryu, H. (2014). A Design Thinking Rationality Framework: Framing and Solving Design Problems in Early Concept Generation. *Human-Computer Interaction*, 29(5–6), 516–553. <https://doi.org/10.1080/07370024.2014.896706>
- Kimbell, R., & Stables, K. (2008). *Researching Design Learning*. Dordrecht, The Netherlands: Springer.
- Kola, M. I. (2017). Technology Teacher Trainees' Lesson Planning Approach in South Africa: Room for Improvement. *African Journal of Research in Mathematics, Science and Technology Education*, 21(3), 293–303. <https://doi.org/10.1080/18117295.2017.1379215>
- Kruger, C., & Cross, N. (2006). Solution driven versus problem driven design: Strategies and outcomes. *Design Studies*, 27(5), 411–435. <https://doi.org/10.1016/j.destud.2006.01.001>
- Lawson, B., & Dorst, K. (2009). *Design Expertise*. Oxford: Architectural Press.
- Mathumbu, D., Rauscher, W., & Braun, M. (2014). Knowledge and cognitive process dimensions of Technology teachers' lesson objectives. *South African Journal of Education*, 34(3), 01–09. Retrieved from [http://0-www.scielo.org.za/innopac.up.ac.za/scielo.php?script=sci\\_arttext&pid=S0256-01002014000300009&lng=en&nrm=iso&tlng=es](http://0-www.scielo.org.za/innopac.up.ac.za/scielo.php?script=sci_arttext&pid=S0256-01002014000300009&lng=en&nrm=iso&tlng=es)
- McLellan, R., & Nicholl, B. (2011). "If I was going to design a chair, the last thing would look at is a chair": Product analysis and the causes of fixation in students' design work 11-16 years. *International Journal of Technology and Design Education*, 21(1), 71–92. <https://doi.org/10.1007/s10798-009-9107-7>
- Menary, R. (2007). *Cognitive Integration: Mind and cognition unbounded*. Basingstoke: Palgrave Macmillan.
- Menary, R. (2010). Dimensions of Mind. *Phenomenology and the Cognitive Sciences*, 9, 561–578.
- Mettas, A., & Norman, E. (2011). A grounded theory approach to the development of a framework for researching children's decision-making skills within design and technology education. *Design and Technology Education: An International Journal*, 16, 8–19.



- Mohedas, I., Daly, S., & Sienko, K. (2015). Requirements Development: Approaches and Behaviors of Novice Designers. *Journal of Mechanical Design*, 137(7), 71407. <https://doi.org/10.1115/1.4030058>
- Naidoo, K. (2011). Poverty and socio-political transition: perceptions in four racially demarcated residential sites in Gauteng. *Development Southern Africa*, 22(2), 277-290.
- Newell, A., & Simon, H. (1972). *Human problem solving*. Englewood Cliffs, NJ: Prentice-Hall.
- Nicholl, B., & McLellan, R. (2005). "Oh yeah, yeah you get a lot of love hearts. The year 9s are notorious for love hearts. Everything is love hearts." Fixation in pupils' design and technology work (11-16 years). *Design and Technology Education: An International Journal*, 12(1), 34-44.
- Oxman, R. (2001). The mind in Design: A conceptual Framework for Cognition in Design Education. In C. Eastman, M. McCracken, & W. Newstetter (Eds.), *Design knowing and learning: Cognition in Design Education* (pp. 269-297). Oxford: Elsevier.
- Petrina, S. (2007). *Advanced Teaching Methods for the Technology Classroom*. Information Science Publishing. Retrieved from <http://eric.ed.gov/?q=%2522Petrina+Stephen%2522&ff1=pubBooks&id=ED508836>
- Petrina, S. (2010). Cognitive Science. In P. A. Reed & J. E. LaPorte (Eds.), *Research in Technology Education: 59th Yearbook*. United States of America: Council on Technology Teacher Education.
- Petrina, S., Feng, F., & Kim, J. (2008). Researching cognition and technology: how we learn across the lifespan. *International Journal of Technology and Design Education*, 18, 375-396. <https://doi.org/10.1007/s10798-007-9033-5>
- Pieper, J. (2013). High School Students' Use of Paper-Based and Internet-Based Information Sources in the Engineering Design Process. *Journal of Technology Education*, 24(2), 78-95.
- Ramaligela, M. S., Gaigher, E., & Hattingh, A. (2014). Exploring the use of Technology textbooks in medium- and well-resourced school contexts in South Africa. *Africa Education Review*, 11(2), 183-200. <https://doi.org/10.1080/18146627.2014.927156>
- Reed, S. K. (2016). The Structure of Ill-Structured (and Well-Structured) Problems Revisited. *Educational Psychology Review*, 28(4), 691-716. <https://doi.org/10.1007/s10648-015-9343-1>
- Restrepo, J. (2006). Studying Design Engineers use of Information Systems: Which variables to control for. *Design Research Society International Conference*, Lisbon.
- Restrepo, J., & Christiaans, H. (2004). Problem Structuring and Information Access in Design. *The Journal of Design Research*, 4(2). <https://doi.org/10.1504/JDR.2004.009842>
- Robbins, P., & Aydede, M. (2009). A Short primer on situated cognition. In P. Robbins & M. Aydede (Eds.), *The Cambridge Handbook of Situated Cognition* (pp. 3 - 10). New York: Cambridge University Press.
- Robertson, I. (2017). *Problem solving: Perspectives from Cognition and Neuroscience* (2nd ed.). London: Routledge.
- Simon, H. A. (1973). The structure of ill structured problems. *Artificial Intelligence*, 4(3-4), 181-201. [https://doi.org/10.1016/0004-3702\(73\)90011-8](https://doi.org/10.1016/0004-3702(73)90011-8)
- Song, T., Becker, K., Gero, J., DeBerard, S., Lawanto, O., & Reeve, E. (2016). Problem Decomposition and Recomposition in Engineering Design: a Comparison of Design Behavior between Professional Engineers, Engineering Seniors, and Engineering Freshmen. *Journal of Technology Education*, 27(1). <https://doi.org/10.21061/jte.v27i2.a.3>
- Stables, K. (2010). The Inspiration Pitch: Where do design ideas come from? In *The Design and Technology Association Research Conference* (pp. 111-121). United Kingdom: Keele University.
- Stemler, S. E. (2004). A comparison of consensus, consistency, and measurement approaches to estimating interrater reliability. *Practical Assessment, Research & Evaluation*, 9(4).
- Strimel, G., & Grubbs, M. (2017). A Critical Examination of Engineering Design Processes and Procedures. In L. Litowitz & S. Warner (Eds.), *Technology and engineering education: Fostering the creativity of youth around the globe*. Philadelphia, PA: Millersville University.
- Summers, J. D., Joshi, S., & Morkos, B. (2014). Requirements evolution: Relating functional and non-functional requirement change on student project success. *International Design Engineering Technical Conferences and Computers and Information in Engineering Conference*, Buffalo.
- Teddle, C., & Tashakkori, A. (2009). *Foundations of Mixed Methods Research: Integrating Quantitative and Qualitative Approaches in the Social and Behavioural Sciences*. Thousand Oaks, CA: SAGE.
- Trudell, B. (2007). Local community perspectives and language of education in sub-Saharan African communities. *International Journal of Educational Development*, 27(5), 552-563. <https://doi.org/10.1016/J.IJEDUDEV.2007.02.002>

- Ullman, D., Dietterich, T., & Stauffer, L. (1988). A model of the mechanical design process based on empirical data. *AI EDAM*, 2(1), 33–52.
- Visser, W. (2009). Design: one, but in different forms. *Design Studies*, 30(3), 187–223. <https://doi.org/10.1016/j.destud.2008.11.004>
- Welch, M. (1999). Analyzing the Tacit strategies of Novice Designers. *Research in Science & Technological Education*, 17(1), 19–34. <https://doi.org/10.1080/0263514990170102>
- Welch, M., & Lim, H.S. (2000). The strategic thinking of novice designers: discontinuity between theory and practice. *The Journal of Technology Studies*, 26. <https://doi.org/10.21061/jots.v26i2.a.6>
- Wells, J. G., Lammi, M., Gero, J., Grubbs, M., Paretti, M., & Williams, C. (2016). Characterizing design cognition of high school students: Initial analyses comparing those with and without pre-engineering experiences. *Journal of Technology Education*, 27(April), 78–91. <https://doi.org/10.21061/jte.v27i2.a.5>
- William, D. (2011). *Embedded formative assessment*. Bloomington, IN: Solution Tree.
- Wu, Q., & Wang, Y. (2015). To explore the effect of sub consciousness on Sudden Moments of Inspiration (SMI) in the sketching process of industrial design. *International Journal of Technology and Design Education*, 25(4), 563–584. <https://doi.org/10.1007/s10798-015-9326-z>
- Yin, R. (2014). *Case Study Research: Design and Methods* (5th ed.). Los Angeles: SAGE.

APPENDIX A

The Design Task

Name: \_\_\_\_\_ Participant: \_\_\_\_\_

**Problem Statement**

A timber company cuts down trees in a forest and uses trucks to transport the logs to a nearby sawmill. It takes very long for workers to manually load the logs onto a truck one by one. The company needs a machine that can pick up logs from the ground and transfer them onto a truck quickly and safely.

**Fig. 1: Workers carrying logs** (Uisso, 2015)



**Fig. 2: Workers loading logs unto trucks** (Jose, 2011a)



**Fig. 3: Workers carrying logs** (Jose, 2011b)



**Fig. 4: Loaded trucks with logs** (Jose, 2011c)



**Design task**

**Design a model of a machine that can pick up logs from the ground and transfer them onto the transport truck. You only have to design the lifting machine, not the truck.**

Most machines consist of several mechanisms that are combined to do a task. Your model must consist of at least two sub-systems:

- One of the sub-systems must consist of one or more mechanism that give mechanical advantage, such as *levers, linkages, wheels, cams, cranks, pulleys, gears, hydraulic or pneumatic systems.*
- The other sub-system must control the movements of the machine. Safety requirements demand that a load must not fall when the effort is removed. If the lifting process is interrupted for some reason, gravity may cause the load to drop back again. This could damage the load or the mechanical system, or it may hurt people nearby. Your design must include a mechanical control system such as a *cleat, or a ratchet and pawl,* to prevent the reverse action and/stop the movement.

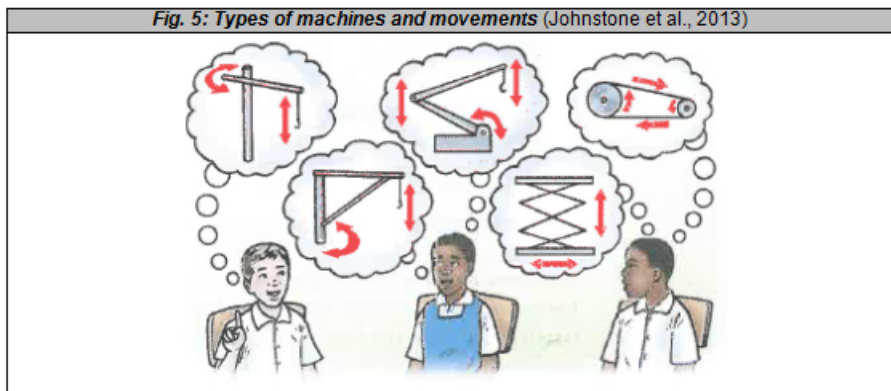
### Instructions

In this design task, you will be working in a group. You are required to design a machine that can load logs onto a truck. Throughout the design task you may use information from your memory, textbook, workbook and cell phone if you need it. You are also allowed to highlight, make notes and draw sketches on all the pictures and notes given to you.

1. Consider the environment in which the machine must function. Discuss the following questions: (15 minutes)
  - How will the environment in which the machine will operate affect its operation?
  - Will the machine always stay in the same position?
  - How high will it have to lift the logs?
  - How will you ensure that the machine will not topple over?
  - How will the machine make work quicker and faster?
2. Think about the movements your machine will need to perform. Which mechanisms can you use to? (20 Minutes)
  - Pick up and hold the logs
  - Lift the logs
  - Create different movement in different parts of the machine
  - Control the movements of the machine (*Gravity may cause the load to drop back and be damaged. Consider how to incorporate a control mechanism in your machine to stop this from happening*).
  - Move the machine around, if necessary

**Make as many notes of your ideas by writing and drawing rough preliminary sketches with arrows and labels to describe movements.**

Fig. 5: Types of machines and movements (Johnstone et al., 2013)



3. Suggest at least two possible designs that will be able to transfer logs from the ground onto a truck. (25 minutes)



**Additional information**

**Fig. 6: Workers in the logging environment** (SA Forestry Magazine, 2011a)

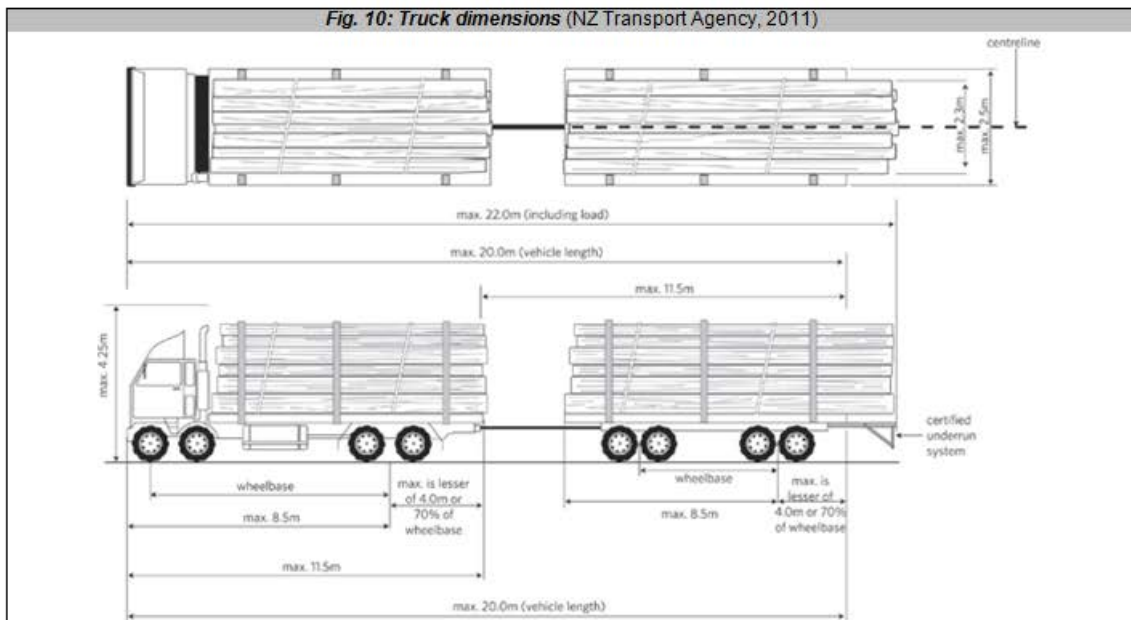


**Fig. 7: Team of workers for lifting logs onto trucks** (SA Forestry Magazine, 2011b)



**Fig. 8: Person packing and arranging logs on the truck** (Logging on, 2009)







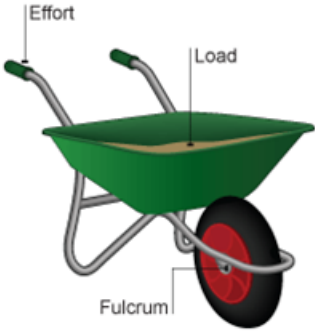

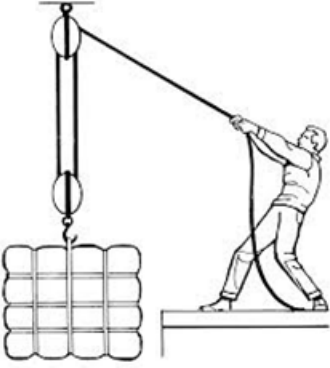
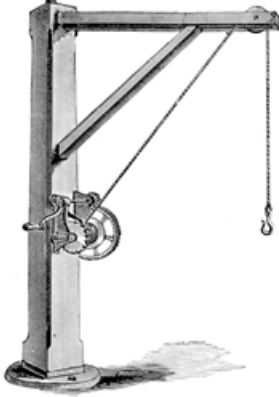


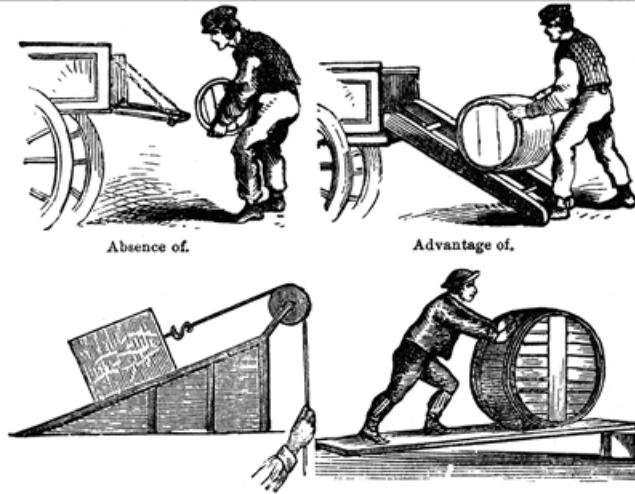
<b>Mechanisms</b>	
<p><b>Fig. 11: Levers</b> (BBC, 2014)</p> 	<p><b>Fig. 12: Linkages, wheel and axle and hydraulic system</b> (Mason &amp; Croft, 2014)</p> 
<p><b>Fig. 13: Pulley system</b> (The Mighty Quill, 2014)</p> 	<p><b>Fig. 14: Gear and crank system</b> (Edwin Harrington, Son &amp; Co., 2010)</p> 
<p><b>Fig. 15: Ratchet and pawl</b> (Automation components, 2012)</p> 	<p><b>Fig. 16: Cleat</b> (Blind technique, 2015)</p> 

Fig. 17: Inclined planes (Florida Centre for Educational Technology)



Existing solutions

Fig. 19: Simple winching system (Mostacedo, 2010)

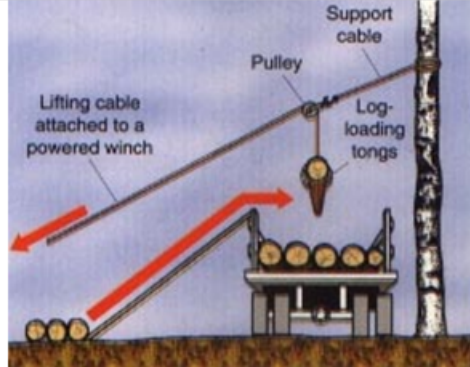
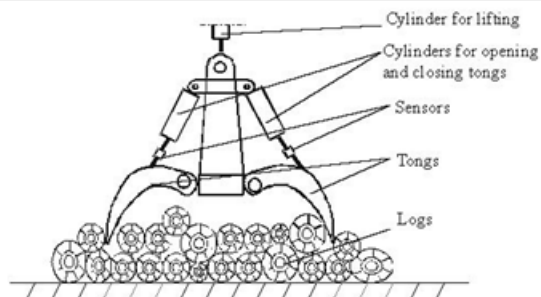


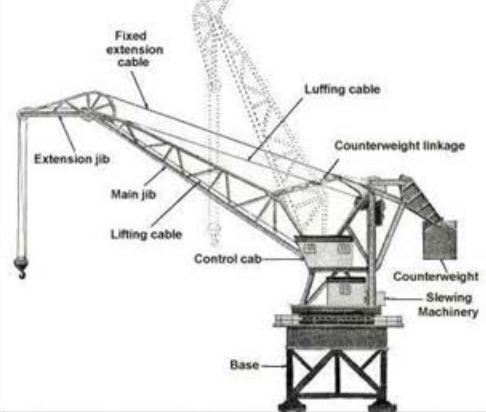
Fig. 20: Hydraulic tongs (Wang, LeDoux & Wang, 2005)



**Fig. 21: Hydraulic crane** (Logging on, 2009)



**Fig. 22: Electrically powered crane** (Admin, 2011)



**Fig. 23: Manual crane** (Princess Auto, 2015)

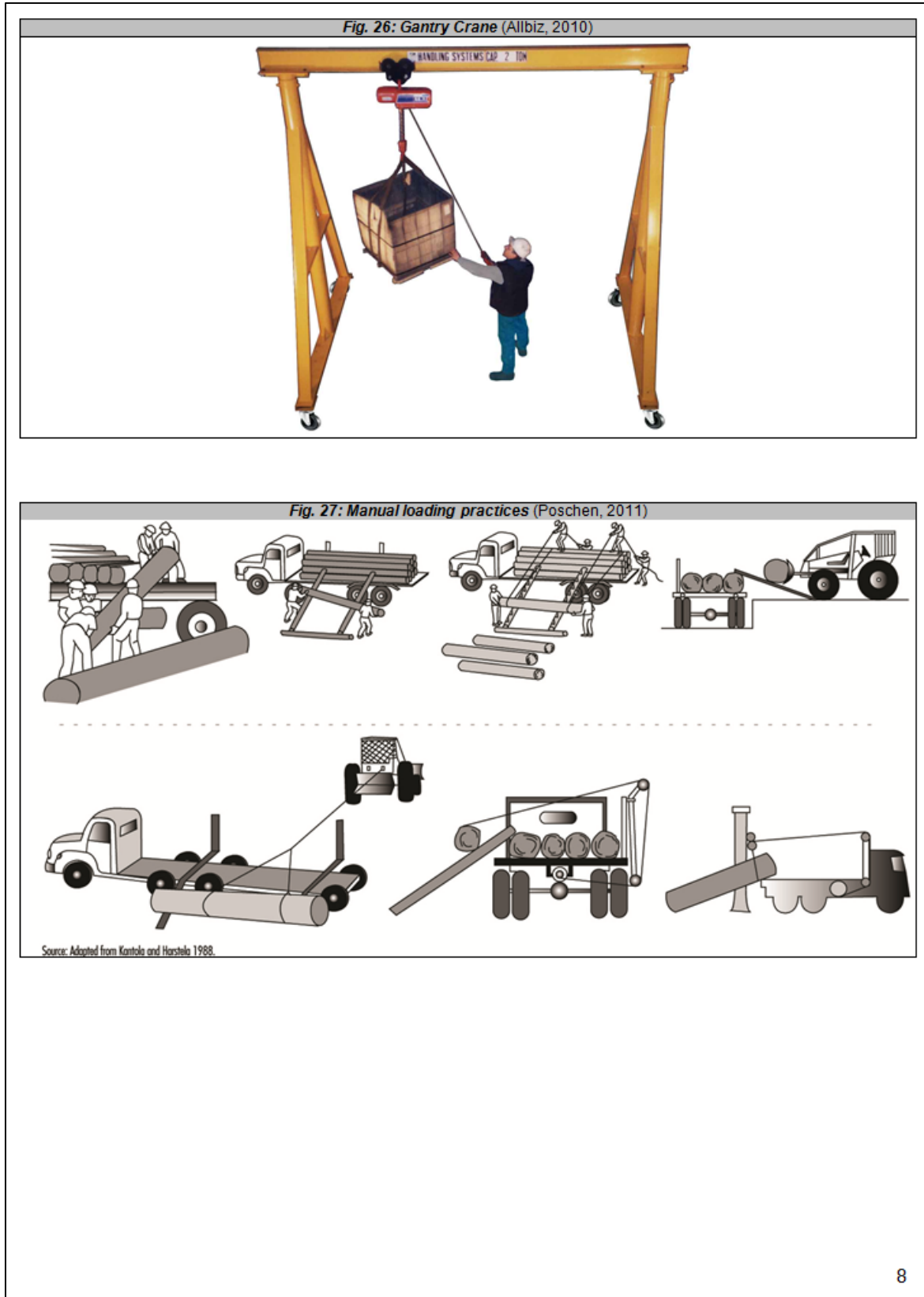


**Fig. 24: Log hauler** (Forestry Department, 1995)



**Fig. 25: Electrically powered crane on truck** (Desertdrover, 2012)





## Research into the Effects of an ICALL Program on Teaching Word Classes to Learners of English

Rüya Mert Altıncı<sup>1</sup>, Behbood Mohammadzadeh<sup>1\*</sup>

<sup>1</sup> Cyprus International University, Lefkosa, NORTHERN CYPRUS

Received 8 March 2018 • Revised 1 April 2018 • Accepted 3 April 2018

### ABSTRACT

This study investigated the effectiveness of an intelligent computer-assisted language learning (ICALL) program on learning word classes to Turkish learners of English. Learning word classes is a common problem for Turkish students, so the main aim of this research is to help students to overcome this problem. Within the scope of this research, an ICALL application with a word class analyzer was developed and used on Foundation English School Students to measure its effects on students' achievement in the mastery of word classes and also their attitudes toward such an ICALL environment. The study employed a pre-test—post-test control group design. The sample consisted of 38 B1 level students who were divided into experimental and control groups. The *t* test was used to investigate the differences between the experimental and control groups. Learners' achievements in the knowledge of word classes were measured. The results showed that the reading activities with this system had positive effects on students' word classes learning and their attitudes toward the intelligent computer-assisted language learning tool. According to the statistical results obtained from the study, there is a significant difference between the groups in favor of the experimental group.

**Keywords:** parts of speech learning, word classes analyzer, ICALL, *reading*

### INTRODUCTION

It is a fact that technology is in every part of our lives. 20 years ago, teachers who teach language skills by using computer technology were accepted as innovative, today the ones who don't adapt the technology to the classroom are considered as out-of-date (Chapelle, 2008). It has been proven that using computer in language learning has several important advantages such as multimedia-based learning, simulation-based learning, self-paced learning and immediate feedback which cannot be done by traditional methods (Bax, 2011; Butler-Pascoe & Wiburg, 2003; Butler-Pascoe, 2011; Choi, 1991; Dudeney, 2007; Lamy & Hampel, 2007; Levy, 1997). There are some terms related to the computer in education; which are CASLA (Computer Applications in Second Language Acquisition) (Chapelle, 2001), CAI (Computer-Assisted Instruction), CAL (Computer-Assisted Learning), CBI (Computer-Based Instruction), CDI (Computer-Directed Instruction), and CMI (Computer-Managed Instruction). CAL is synonymous with CAI. What is more, CALL is another term which is both a part of CAI and related to language teaching (Yang, 2011). CALL stands for "Computer-Assisted Language Learning" which is used to describe the role of computers in terms of language teaching (Hardisty & Windeatt: 1989). It is also defined as "the search for and study of applications of the computer in language teaching and learning" by Levy (1997). In other words, CALL is based on teaching English by using computers. Lee (2000) suggests 8 reasons to use CALL which are (1) Experimental learning, (2) Motivation, (3) Enhancing student achievements, (4) Authentic materials, (5) Greater interaction, (6) Individualization, (7) Independence from a single source of information and (8) Global understanding. CALL provides more interactive teaching along with a highly individualized instruction. It is a student-centered instruction and even the speed of the lessons can be controlled by the students. Another aspect of CALL is that it can fit learners' level and evaluate learners' responses (Chapelle, 2008). To sum up CALL is flexible, patient and sensitive to a learners' pace, students can set their own speed of work, it gives responses and it can



### Contribution of this paper to the literature

- This paper introduces a new effective way to teach word classes to Turkish EFL learners.
- The study highlights the importance of using ICT in teaching English through literary texts.
- The ICALL program the study presents can be used everywhere and every time via all ICT devices.

answer the real needs of the individuals and what is more, it increases motivation (Ahmad et al., 1985:5; Calvo, 1997).

Based on our observations during English lessons, we realized that Turkish ESL students commonly suffer from lack of parts-of-speech knowledge and that causes their failure especially in cloze tests. We brainstormed about it in an attempt to find a solution to it. Finally we came up an idea of using technology to overcome this problem. Teaching parts-of-speech directly is not as effective as we want, so the method we are looking for is based on indirect teaching. For this reason a web based system has been developed to help students to differentiate parts-of-speech. This system is designed as autonomous learning activity because in language teaching “perception” is the key (Derwing & Munro, 2005). Students need to apprehend the parts-of-speech concept on their own for retention learning. It is believed that with the help of this system, students will improve their parts-of-speech knowledge by the end of the study.

## LITERATURE REVIEW

### Intelligent CALL Programs

Uses of computers in language teaching dated back to the 1960s. During this period CALL can be divided into three main stages which are Behaviorist CALL, Communicative CALL and the Integrative CALL (Lee, 2000). There are also three important time periods in terms of significant developments in CALL: The 1960s and 1970s, the 1980s and the 1990s (Levy, 1997). In 1960s, Computer-assisted language learning was supported by mainframe computers. “Courseware” (Computer-based language learning activities) was developed through programming languages and stored on a mainframe for learners (Chapelle, 2001). The PLATO and TICCIT are the significant projects of the 1960s and 1970s (Levy, 1997). During the early 1980s, with the rising of cheap microcomputers, CALL industry was on the rise. *Storyboard* and *the Athena Language Learning Project (ALLP)* are important works of the 1980s (Levy, 1997). With the involvement of the internet, the most significant improvement has occurred in educational technology. *The International Email Tandem Network*, *the CAMILLE/France InterActive Project* and *the Oral Language Archive (OLA)* are the prominent projects of the 1990s (Levy, 1997). According to Murphy (2000), 20<sup>th</sup> century CALL technology is based on behaviouristic and communicative CALL and the 21<sup>st</sup> century CALL technology will depend on Technology Enhanced Language Learning (TELL). With TELL, the role of technology changes and education adapts a constructivist, student-centered approach.

There are eight CALL applications that can be used or developed for projects. These are (1) Word processing, an application for spelling, (2) Games such as hangman, (3) Literature, for reading skills, (4) Corpus Linguistics, in terms of real world samples, (5) Computer-mediated communication (CMC), For instance e-mail, chat, (6) WWW resources, (7) Adapting other materials for CALL and (8) Personal Digital Assistants (PDAs) & Mobile Phones (Beatty, 2013). Warschauer and Healey (1998) claim that there are three ways to help language learners develop reading skills which are incidental reading, reading comprehension and text manipulation. It has been claimed that ESL learners’ reading activities through a CALL program are more effective than the traditional ones. According to several researches, CALL improves reading comprehension (AlKahtani, 1999; Busch, 2003; Gorjian, 2008; McGlenn & Parrish, 2002). Abraham (2008) and Cummins (2008) also examined the effect of computers on reading comprehension and the determined that computer assisted reading activities are highly effective.

Several studies have been done on effectiveness of CALL in grammar teaching. For instance Pirasteh (2014) tested CALL for teaching 15 grammar points. 52 learners were divided into two groups. Experimental group have learned these grammar points through computer and control group through printed paper. Results showed that the experimental group have been more successful in the post test than the control group. Naba’h et al. (2009) used CALL to teach passive voices on 212 students. Experimental group students who have used computer outperformed control group students who have used traditional method. Nutta (1998) has also done a research on effectiveness of CALL in grammar teaching on 53 students and it is determined that teaching grammar structures through CALL is more effective than traditional methods. Finally Nagata (1996) compared CALL and workbook instruction in terms of grammar teaching on 26 students and it is found that CALL is more effective than using workbook.



## Word Classes

In all languages in the world, words can be categorized into classes according to their semantic and syntactic functions (Gardenfors, 2014). "Word class" can be used instead of "part-of-speech" (Van Lier & Rijkhoff, 2013). The term word class was introduced by structuralist linguists in the twentieth century. Another equivalent term is "Syntactic category" called by Chomskyan linguists (Haspelmath, 2001).

Word classes are groups of words with similar behaviours (Vulanovic & Miller, 2010). Hockett (1958: 2219) explained parts-of-speech as form class stems that have similar features in inflection, syntax, or both of them. Native speakers unconsciously have a word classification system (Alderson, Clapham, & Steel, 1997). However, second language learners must create a new system. They can start to do that through direct transfer from their first language (Schmidst, 2001).

Word classes dates back to ancient times (Gil, 2000). Aristotle and the Stoicks used to have their own part-of-speech lists. However Throx's set of eight became the basis for all parts-of-speech description of Latin, Greek and most European languages. Those eight parts-of-speech were noun, verb, pronoun, preposition, adverb, conjunction, participle and article (Jurafsky & Martin, 2000). Adjectives have been accepted as a word class since the second half of the 18<sup>th</sup> century. Latest lists of word classes (or tagsets) had more classes such as 45 for the Penn Treebank tagset (Marcus, Santorini, & Marcinkiewicz, 1993), 87 for the Brown Corpus tagset (Francis, 1980; Francis & Kucera, 1982) and 146 for the C7 tagset (Garside & McEnery, 1997). Nowadays noun, verb, adjective, adverb, pronoun, preposition, conjunction and interjection are "traditional word classes" (Gardenfors, 2014; Van Lier & Rijkhoff, 2013). Auxiliaries are not included in the traditional word classes list. The reason of it is probably the fact that they are not prominent in Latin and Greek grammar (Haspelmath, 2001).

In most languages, word classes are divided into two main categories. These categories are "Content words" and "Function words". Nouns, verbs, adjectives and adverbs are content words. However, prepositions, conjunctions, articles, auxiliaries and particles are function words (Haspelmath, 2001). Jurafsky and Martin (2000), on the other hand, claimed that parts-of-speech are divided into two classes which are "closed class types" and "open class types". Prepositions are a closed class because they are fixed. On the contrary, Nouns and verbs are open classes because they welcome new nouns and verbs continually. Another opinion in terms of classification of words classes is DeCapua's. DeCapua (2008) said that parts-of-speech are divided into as "form and structure classes" in many grammar texts. Form classes are the major parts-of-speech such as nouns, verbs, adjectives and adverbs. However, the structure classes are the minor parts-of-speech which are prepositions, pronouns, conjunctions and others.

Word classes are predictors of better text comprehension (Mikk, 1997). The most important aspect of parts-of-speech (also known as POS, Word classes, Morphological classes or Lexical tags) is the amount of information they provide to a word. Knowing whether a word is a possessive pronoun or a personal pronoun helps students a lot. For instance possessive pronouns are mostly followed by a noun and personal pronouns by a verb (Jurafsky & Martin, 2000). On the other hand, there is a problem which is that some of the classes intersect. In other words one word can be in more than one class. For instance; "there" is a both a pronoun and adverb (Haspelmath, 2001). To sum up, word classes in English do not always rely on word endings or forms. Context and sentence positions in English are key points in terms of clarifying the function of a word, because word order in English is fixed (DeCapua, 2008).

## Research Questions

The main research problem is divided into two research questions and two sub-questions which are presented below:

1. Do reading activities with Graffor and traditional reading activities differ in enhancing ESL learners' *grammar knowledge*?
  - (a) Do reading activities with Graffor and traditional reading activities differ in enhancing ESL learners' grammar with regard to *the development of parts-of-speech knowledge*?
  - (b) Do reading activities with Graffor and traditional reading activities differ in enhancing ESL learners' grammar regarding *how words function in context*?
2. Do reading activities with Graffor affect learners' *attitudes to CALL* compared to traditional reading activities?
  - (a) Do reading activities with Graffor affect learners' opinions of *the usefulness of ICALL programs* compared to traditional reading activities?
  - (b) Do reading activities with Graffor affect learners' *anxiety about CALL programs* compared to traditional reading activities?

## METHOD

### Research Design

This study applies quantitative and qualitative methods together to analyze the collected data. Fraenkel and his colleagues state that “quantitative researchers seek to establish relationship between variables and look for and sometimes explain the causes of such relationship” (Fraenkel, Norman, & Hyun, 2012: 11). This study attempts to find the effectiveness of a CALL program on word classes learning. Therefore, we use a quantitative data analysis procedure in order to find out the relationship between the variables. This method will enable us to generalize our results to the same setting. We also use a qualitative data analysis procedure in order to find out students’ attitudes toward the CALL program.

### Participants

Thirty-eight university students who studied intermediate level (B1) English at Foundation English School of Girne American University (GAU) participated in the research. Students whose ages range from seventeen to twenty had been divided into groups at the beginning of the semester by the administration. Volunteer students (22 male - 16 female) from the groups named as B1.7 and B1.8 were the participants of the research. B1.7 (Control Group) contained 19 students. B1.8 (Experimental Group) had 19 students as well. Both groups, after taking the pre-test, followed the same reading texts in two different ways. Experimental group have studied word classes through computer and control group have studied them through printed texts. The aim of the lessons was to teach word classes and the function of the words in context. After the one month of training, both groups took the post test.

### Measurement Tools

For this study, two tests were designed by the researcher. A pilot study has been done. The reliability of the tests was measured by using Cronbach’s alpha. The values are satisfactory: the value of test 1 is 0.84 and the value of test 2 is 0.61. The content validity was determined through the opinions of three experts who are professors in ELT department at Cyprus International University. Learners’ attitudes toward Graffor were gathered through a focus group. Six volunteers were selected randomly from among the experimental group students and focus group interviews were done with them.

### The System

Graffor is a CALL program with a word classes analyzer. It consists of 11 short stories of Oscar Wilde. According to Inn-Chull (2016) using short stories in grammar learning (in our case, more specifically parts-of-speech learning) takes learners’ attention and help them to focus on grammatical concepts without dealing with contextual comprehension of the short stories. Therefore, the aim of our system is to facilitate reading skills of Turkish students who are learners of English and improve their parts of speech knowledge while reading in English. The system has a module which can:

1. show word classes of every word in the system
2. provide an explanation why the word belongs to that particular class

### Pedagogic Design

The Graffor system has been designed to help learners to learn word classes in context and increase their language awareness. It is an out-of-class online learning tool which can be used whenever and wherever learners want to use. This not only facilitates a student-centered learning environment but also increases learners’ contact time with the foreign language. Students can easily connect to the system by using their e-mails and a password given by the researcher, through the following website link: “[www.graffor.com](http://www.graffor.com)” (See **Figure 1**). The system based on a reading activity that consists of eleven B1 level short stories. Students can choose any story they want to read (See **Figure 2**). The best part of the system is that each learner has the opportunity to choose any story he or she wants to read and click on any word that seems unfamiliar to him or her while reading. As soon as the word is clicked, the word classes analyzer is automatically activated and the word class of the word displayed in the “parts of speech” window on the right along with its explanation in the “Rules” window under the “parts of speech” window (see **Figure 3**).

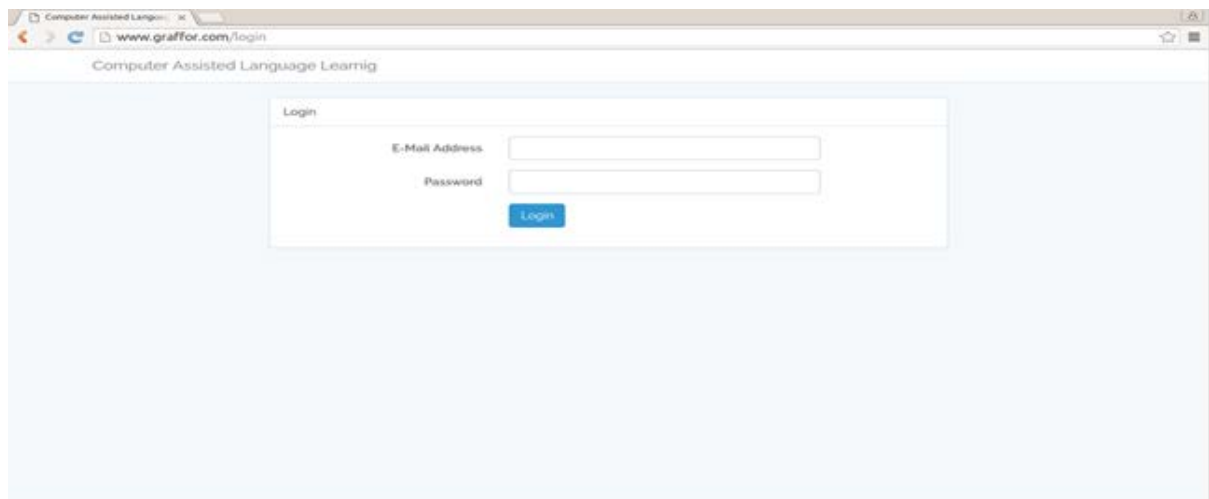


Figure 1. www.graffor.com

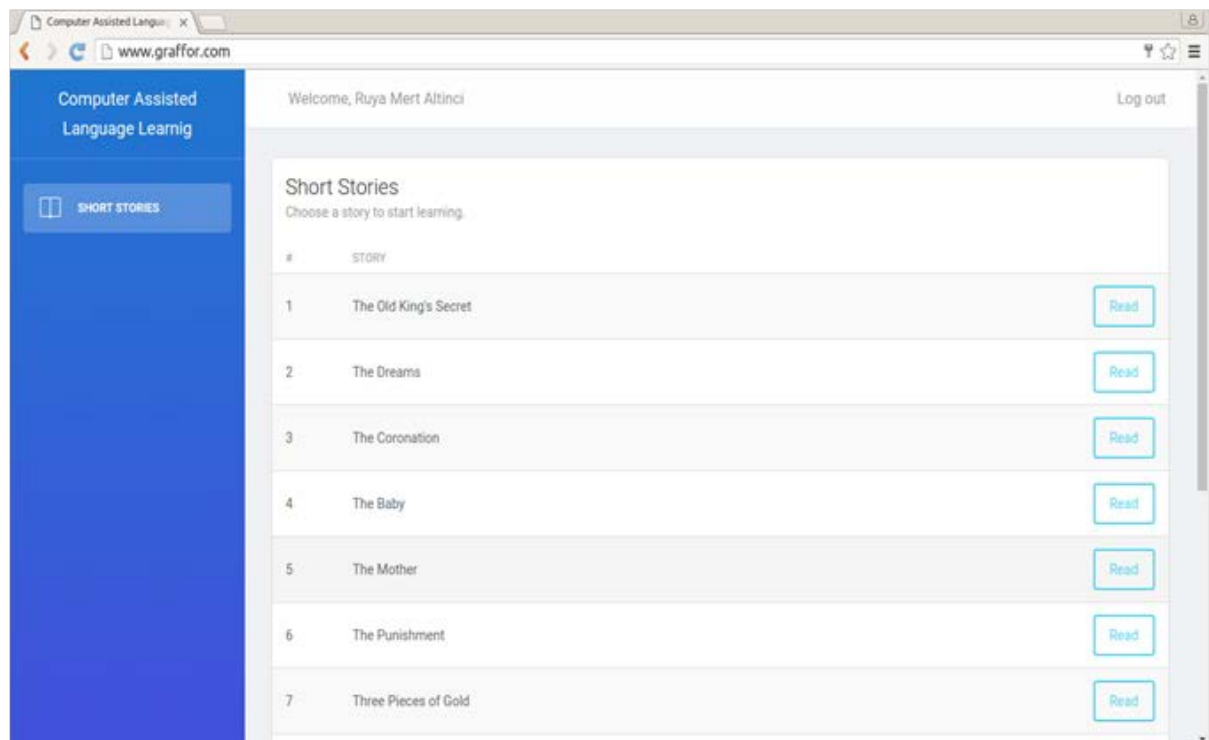


Figure 2. Short Stories

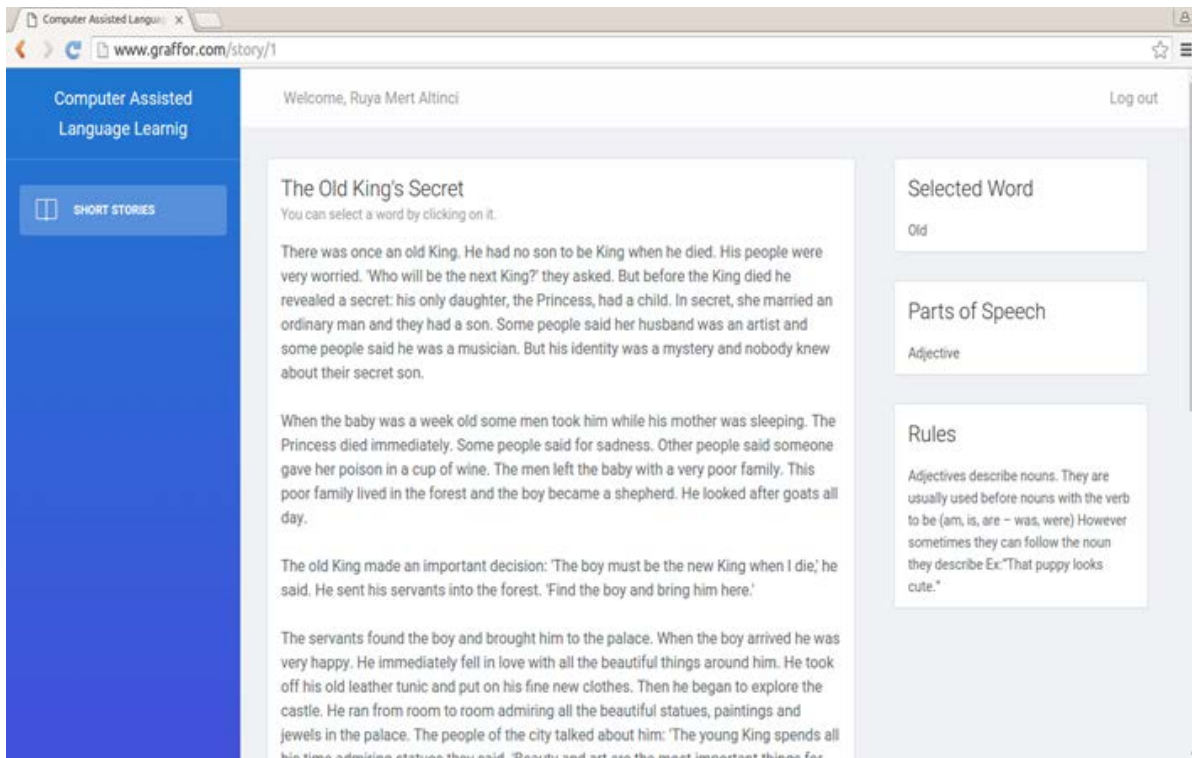


Figure 3. The Graffor user interface

## Performance Analysis

The Graffor system consists of 11 short stories and total 6377 words. There are 891 unique words and all eight parts-of-speech in the system which helps students to be aware of different types of parts-of-speech. In order to test functional performance of the system, all words were checked by the researcher and the accuracy of the words in terms of part-of-speech and their rules were also analyzed. During the test three problems were encountered:

**(1) Flexible Words:** Some words in the system have two meanings. Such as “well” which is both a noun and an adjective according to the context. In these cases, the rules section has both rules of nouns and adjectives so learners are supposed to read the rules and decide on whether the “well” is a noun or an adjective according to the context. For instance; according to the rules section if it is a noun, there must be an article (a, an, the) before the singular nouns, so if in the context, it says “there is a well” the “well” here is a noun. This problem is a challenging one, because learners will be able to practice what they have learned.

**(2) Phrasal verbs:** The system fails to analyze phrasal verbs it analyzes them as single words. For instance “look after” is considered as “look-verb” and “after-preposition”. It is not a big problem, because it is known that phrasal verbs are combination of verbs and prepositions. Also our aim is to teach parts-of-speech, this way is much easier for beginners.

**(3) Prepositions:** Another problem the system had created is preposition problem. Analyzing the one-word prepositions such as, “in, on, at, between, behind...” is fine. However prepositions more than one word have problems. The system doesn’t analyze them together. It does it separately. For instance “in front of” is analyzed as “in-preposition” “front-noun” “of-preposition”. Still it is not a big problem in terms of parts-of-speech learning at all.

## Underlying Technology

There are four issues to take into consideration in order to develop a system with a part-of-speech analyzer:

1. Creating an online website
2. Building a corpus story module
3. Determining parts-of-speech of the words
4. Creating rules for each part-of-speech

The main function of Graffor is to help Turkish students to be aware of parts-of-speech. It has two basic components which are (1) story module and (2) parts-of-speech and their rules segments. It doesn't show definition of the words or their morphemes. However it does show hints to guess parts-of-speech of the words without even knowing meaning of the words.

Graffor is a web based application and it is written with Hypertext Preprocessor (Php) language which is a server-side scripting language, designed for web development. Php is backed with a relational database management system (RDBMS) called MySQL to store and fetch all the stories, rules and parts-of-speech of the words in the system. The system provides an open access through the web for everyone that has a valid username and password that is in the database. Graffor system has 3 components: story corpus module, parts-of-speech (POS) module, and the rules module. Story corpus module consists of the short stories of Oscar Wilde in the system. POS module is a key value dictionary where "key" is the word and value is the part of speech of the word. Parts of speech of the words in the stories have been determined and classified before and then stored in the database for fast and reliable access for the students. The system supports word flexibility as well. To make it clear, if a word belongs to more than one word classes, the system shows all of them. The rules module consists of the information related to all word classes. Each word class has its own rules, key hints and examples in the system which can be seen by clicking on the related words.

### Procedure and the Analysis of Data

The research employed a pre-test - post-test design. The control group learned parts-of-speech and read Oscar Wilde's short stories (2003) from the book. While reading, they also analyzed the word classes through traditional ways such as the use of dictionary. However, the experimental group learned parts-of-speech and read Oscar Wilde's short stories through Graffor. Both groups did the research as out-of-class activity. In short, both groups read exactly the same stories, but the experimental group used only the electronic version of it. The research consisted of two tests (test 1 with 17 questions and test 2 with 15 questions). Tests which were used as both pre-test and post-test, developed by the researcher. The researcher selected two or three sentences from each short story and by omitting one word from each sentence, in other words by turning sentences into cloze test, she prepared the word classes tests for the control and the experimental group students. The research took one month and experimental group students' online activities were tracked by the researcher. After the one-month of intensive study period, both control and experimental group students took the post-test.

## RESULTS

The results of Test 1 which are shown in [Table 1](#) and [2](#) indicate that there is a significant difference between the mean scores of experimental and control groups. Especially experimental group's post test results are highly significant. In other words, the experimental group has a statistically significantly higher mean score (10.94) than the control group (1.21). In the light of pre and post test results, it can be said that students who used "Graffor" improved themselves more, in terms of parts-of-speech knowledge.

**Table 1.** (M and SD of Test 1)

Scale type	Group type	N	M	SD	Standard Error Mean
Pre-test	Experimental	19	5.63	4.63	1.06
	Control	19	2	1.68	0.38
Post-test	Experimental	19	10.94	4.04	0.92
	Control	19	1.21	1.00	0.23

**Table 2.** (t-test results of Test 1)

Scale type	t	p	Mean difference
Pre-test	3.212	0.002	3.631
Post-test	10.190	0.0001	9.736

The results of Test 2 are shown in [Table 3](#) and [4](#). According to the tables, mean scores of the experimental group are statistically significant (pre- 6.94 - post: 11.84) comparing to mean scores of the control group (pre: 4.15 - post: 3.84). While pre-test results do not have statistically significant difference between two groups (experimental: 6.94 control: 4.15), post test results do have. This difference can be interpreted as the students who used traditional methods for parts-of-speech knowledge did not improve themselves as much as the students who used the CALL program "Graffor".

**Table 3.** (M and SD of Test 2)

Scale type	Group type	N	M	SD	Standard Error Mean
Pre-test	Experimental	19	6.94	3.25	0.74
	Control	19	4.15	2.15	0.49
Post-test	Experimental	19	11.84	2.58	0.59
	Control	19	3.84	2.83	0.65

**Table 4.** (t test results of Test 2)

Scale type	t	p	Mean difference
Pre-test	3.120	0.003	2.79
Post-test	9.105	0.0001	8

With regard to research question 1 (Do reading activities with Graffor and traditional reading activities differ in enhancing ESL learners' *grammar knowledge*?) students in the experimental group enhanced their grammar knowledge more than the ones in the control group. It can be seen from the mean scores above. After one-month, students took the post tests. The purpose of the delayed posttest was to check learners' retention in terms of parts-of-speech knowledge. Students in the experimental group got higher marks compared to the control group students. All students in the experimental group had more correct questions in their posttests compared to their pretests so this means there is an obvious improvement in their parts-of-speech knowledge. On the other hand students in the control group had almost the same results both in pre and posttests. Some of them even got the lower marks. Therefore, it can be said that experimental group's retention success is higher than the control group. In other words, there is a significant difference in the retention of the parts-of-speech by the control and experimental group students' tests. The tests were in cloze test format because cloze tests are language teaching tools which help students to check their knowledge about lexical items. Cloze tests help students to predict the missing word and by doing this, students learn information about the grammar and vocabulary of a language (Mohammedzadeh, 2015). According to Simpson (1997) cloze test are designed on the purpose of increasing learners' knowledge about choosing the appropriate lexical items for related grammatical contexts. To conclude, it can be deduced that reading activities with Graffor is more effective than traditional methods in terms of development of both parts-of-speech knowledge and function of the words.

With regard to research question 2 (Do reading activities with Graffor affect learners' *attitudes to CALL* compared to traditional reading activities?) students' attitudes toward the CALL program were positive. Students in the experimental group were enthusiastic about the study and they were eager to use the system at home. They considered it as a game. On the other hand students in control group were not happy to get extra papers to read at home. They considered it as homework. According to the CALL focus group, all students who used the tool, found the system useful.

The followings are the students' responses in the focus group: *Question 1: What do you think about the usefulness of Graffor compared to traditional reading activities?*

*Low achiever participant:* I think this program is useful. It is easy to use. It is not boring like using dictionaries. Although I couldn't use it much because of work, I think it is better than traditional methods.

*Moderate achiever participant 1:* I think it is really useful. I have started to understand how words function in a sentence. The rules section in the system really helped me. I prefer to use this system instead of traditional methods.

*Moderate achiever participant 2:* I can say that this new system is really enjoyable. It is also very useful. It is faster than using a dictionary for sure. I believe that I improved myself.

*High achiever participant 1:* I love the system. It is really functional. I used it with my mobile phone whenever I was free. It is definitely better than traditional methods. Now I can analyze sentences and find the missing parts-of-speech in cloze tests.

*High achiever participant 2:* Reading activity with Graffor is really useful and fun. I really liked to use technology. It is different. When I use it, time flies so fast. Now, I know word classes and their functions in sentences better than before.

*High achiever participant 3:* Graffor is quite useful. I have learned lots of new things. Learning word classes through a computer was fun. It was more practical than using traditional methods. I mean, I used it at school, at work, at night. It is easy to use and it doesn't seem like homework. Now parts-of-speech doesn't seem so difficult to me.

*Question 2: Did you have any anxiety about the program?*

*Low achiever participant:* No, I didn't.



*Moderate achiever participant 1:* Yes I did. I thought I couldn't use the tool because I am not good at technology. However I did use it. It was really easy to use.

*Moderate achiever participant 2:* No, I didn't. I found it innovative and enjoyable.

*High achiever participant 1:* No, I didn't. I use my mobile phone all the time, so I liked the idea of using my mobile phone and learning parts-of-speech.

*High achiever participant 2:* No, I didn't. I love technology. My department is computer engineering, so I really liked it.

*High achiever participant 3:* Yes I did a bit. I was anxious about "if I don't understand something or if I have a question, how will I ask it to a computer?" I mean, teachers are always there for us and this thing is new. However, the system was really simple and easy to use. I didn't have any problem.

## DISCUSSION AND CONCLUSION

Just like claims of several researchers, the study shows that CALL application with a parts-of-speech analyzer can help learners to acquire word classes effectively. An ICALL tutoring system with an L2 grammar teaching setting has positive effects on L2 learners and prevents them from incorrect conceptualization of grammatical rules and subsequent fossilization. Therefore, this study eventually leads learners to acquisition of the target grammar (Fotos & Brownne, 2004, pp. 3-14; Matthews, 1993; Stockwell, 2007; Toole & Heift, 2002). The results of the experiment demonstrate that reading activities with Graffor have positive effects on learners' parts-of-speech learning and their attitudes toward the use of CALL program as well.

Studies on SLA have shown that process-oriented language learning where the main aim is the learning process' itself (in our case, computer assisted language learning) is much more effective than product-oriented language learning where the main aim is results (in our case traditional language learning such as learning by answering questions or taking multiple choice tests) (Bolhuis, 2003; Gattegno, 1972; Horowitz, 1986; Richards & Rodgers, 1987; Vermunt & Verschaffel, 2000, pp. 209-225). Both Test 1 and Test 2 results show that posttest mean scores of experimental groups are higher than control groups which proves that "Graffor" system helps students to improve themselves in terms of parts-of-speech/ grammar knowledge. This cooperates with the findings of (Naba'h, Hussain, Al-Omari, & Shdeifat, 2009; Nagata, 1996; Nutta, 1998; Pirasteh, 2014). On the other hand, post test scores of control group are lower. That means students' performance even worse than the pre-test, so according to these data, it can be said that following the traditional methods is not helpful in terms of improvement in parts-of-speech learning.

It is a fact that there are a lot of advantages of computer assisted language learning. However, all of these advantages are up to learners' interest and desire to use it (Hsu, 2016). In this case, ESL learners' acceptance and usage of CALL is quite important. Based on students' opinions about the CALL program, it can be said that Graffor is both useful and enjoyable. All students found it effective even the one who didn't use it much. Some students were anxious about it but they changed their minds as soon as they started to use it. According to students, Graffor was effective, useful, practical, simple, easy to use, innovative and enjoyable. To conclude, students think that with "Graffor" it is fun to learn parts-of-speech. This result also matches up with other results which claim that learners have a positive attitudes toward computer assisted language learning (Al-Juhani, 1991; Askar, Yavuz & Köksal, 1992; Önsöy, 2004).

## SUGGESTIONS

Another version of the Graffor can be created for teaching vocabulary, grammar, pronunciation etc. This research has been carried out on Turkish students. Another research may be done on students with other nationalities as well. There were some limitations during the research such as flexible words; the words belong to more than one word class. The researcher solved this problem by adding all word classes it belongs to the parts-of-speech section, so students had to read the rules, analyze the sentence and decide in which class the word belongs to whenever they come across these flexible words. For further improvements, some suggestions are as follows:

- In the research, repeated words have the same rules which created some trouble in terms of flexible words, so there can be a system in which each word has its own rules.
- The system can be redesigned for vocabulary, grammar and even pronunciation teaching.
- There are only 11 short stories in the system, so number of the words is limited too, so the number of the short stories can be increased.
- Compound words accepted as two individual words, so the system can be developed to overcome this problem as well.

## REFERENCES

- Abraham, B. (2008). Computer-mediated glosses in second language reading comprehension and vocabulary learning: A meta-analysis. *Computer Assisted Language Learning*, 21(3), 199–226. <https://doi.org/10.1080/09588220802090246>
- Ahmad, K., Corbett, G., Rogers, M., & Sussex, R. (1985). *Computers, Language Learning and Language Teaching*. Cambridge: Cambridge University Press.
- Alderson, J. C., Clapham, C. M., & Steel, D. (1997). Metalinguistic knowledge, language aptitude, and language proficiency. *Language Teaching Research*, 1, 93–121. <https://doi.org/10.1177/136216889700100202>
- Al-Juhani, S. O. (1991). *The effectiveness of computer-assisted instruction in teaching English as foreign language in Saudi secondary school* (Unpublished doctoral dissertation), University of Denver, Denver, CO.
- AlKahtani, S. (1999). Teaching ESL reading using computers. *The Internet TESL Journal*, V(11), 1–10. Retrieved on October 23, 2017 from <http://iteslj.org/Techniques/AlKahtaniComputerReading/>
- Aşkar, P., Köksal, M., & Yavuz, H. (1992). Students' perceptions of computer assisted instruction environment and their attitudes towards computer assisted learning. *Educational Research*, 34 (2), 133-139. <https://doi.org/10.1080/0013188920340204>
- Bax, S. (2011). Normalisation revisited: The effective use of technology in language education. *International Journal of Computer-Assisted Language Learning and Teaching*, 1(2), 1-15. <https://doi.org/10.4018/ijcallt.2011040101>
- Beatty, K. (2013). *Teaching & researching: Computer-assisted language learning*. London: Routledge.
- Bolhuis, S. (2003). Towards process-oriented teaching for self-directed lifelong learning: A multidimensional perspective. *Learning and Instruction*, 13(3), 327–347. [https://doi.org/10.1016/S0959-4752\(02\)00008-7](https://doi.org/10.1016/S0959-4752(02)00008-7)
- Busch, H.-J. (2003). Computer based readers for intermediate foreign-language students. *Educational Media International*, 40(3–4), 277–285. <https://doi.org/10.1080/0952398032000113194>
- Butler-Pascoe, M. E., & Wiburg, K. M. (2003). *Technology and teaching English language learners*. Boston, MA: Pearson Education.
- Butler-Pascoe, M. E. (2011). The history of CALL: The intertwining paths of technology and second/foreign language teaching. *International Journal of Computer-Assisted Language Learning and Teaching*, 1(1), 16-32. <https://doi.org/10.4018/ijcallt.2011010102>
- Calvo, M. V. (1997). Computer Assisted Language Learning: Revision of some theoretical principles from a practical case. *Encuentro: Revista de Investigación e Innovación en el aula de idiomas*, 9, 127-134.
- Chapelle, C. A. (2001). *Computer applications in second language acquisition*. Cambridge University Press. <https://doi.org/10.1017/CBO9781139524681>
- Chapelle, C. A. (2008). *Computer assisted language learning* (pp. 585-595). Blackwell Publishing Ltd. <https://doi.org/10.1002/9780470694138.ch41>
- Choi, I.-C. (1991). CALLeui wisang gwa jeonmang [Current status and prospects of CALL]. *English Teaching*, 42, 69-87.
- Cummins, J. (2008). Computer assisted text scaffolding for curriculum access and language learning/acquisition. Retrieved on October 22, 2017 from <http://iteachilearn.com/cummins/elective.html>
- DeCapua, A. (2008). *Grammar for teachers: A guide to American English for native and non-Native speakers*. Springer Science & Business Media. <https://doi.org/10.1007/978-0-387-76332-3>
- Derwing, T. M., & Munro, M. J. (2005). Second language accent and pronunciation teaching: A research--based approach. *TESOL Quarterly*, 39(3), 379-397. <https://doi.org/10.2307/3588486>
- Dudeny, G. (2007). *The Internet and the language classroom* (2nd ed.). Cambridge: Cambridge University Press.
- Fotos, S., & Brownne, S. M. (2004). The development of CALL and current options. In S. Fotos & S. M. Brownne (Eds.), *New perspectives on CALL for second language classrooms* (pp. 3-14). Mahwah, NJ: Lawrence Erlbaum Associates.
- Fraenkel, J., Norman, E. W., & Hyun, H. H. (2012). *How to Design and Evaluate Research in Education*. New York: McGraw-Hill.
- Francis, W. N. (1980). A tagged corpus--problems and prospects. *Studies in English linguistics for Randolph Quirk*, 192-209.
- Francis, W. N., & Kucera, H. (1982). *Frequency analysis of English usage: Lexicon and usage*. Houghton Mifflin.
- Gärdenfors, P. (2014). A semantic theory of word classes. *Croatian Journal of Philosophy*, 14(2), 179-194.
- Garside, R., L, G., & McEnery, A. (1997). *Corpus Annotation*. London and New York: Longman.

- Gattegno, C. (1972). *Teaching foreign languages in schools: The silent way* (2nd ed.). New York, NY: Educational Solutions.
- Gil, D. (2000). Syntactic categories, cross-linguistic variation and universal grammar. *Empirical approaches to language typology*, 173-216. <https://doi.org/10.1515/9783110806120.173>
- Gorjian, B. (2008). Developing linguistic and cultural perspectives of English as a foreign language through email discussion. *The JALT CALL Journal*, 4(3), 3-14.
- Hardisty, D., & Windeatt, S. (1989). *CALL*. Oxford: Oxford University Press.
- Haspelmath, M. (2001). Word classes/parts of speech. In P. B. Baltes, & N. J. Smelser (Eds.), *International Encyclopedia of the Social and Behavioral Sciences* (pp. 16538-16545). Amsterdam: Pergamon Pr. <https://doi.org/10.1016/B0-08-043076-7/02959-4>
- Heward, V. (2003). *Oscar Wilde's short stories retold by Victoria Heward*. Black cat publishing.
- Hockett, C. F. (1958). A course in modern linguistics. *Language Learning*, 8(34), 73-75. <https://doi.org/10.1111/j.1467-1770.1958.tb00870.x>
- Horowitz, D. (1986). Process, not product: Less than meets the eye. *TESOL Quarterly*, 20(1), 141-144. <https://doi.org/10.2307/3586397>
- Hsu, L. (2016). An empirical examination of EFL learners' perceptual learning styles and acceptance of ASR-based computer-assisted pronunciation training. *Computer Assisted Language Learning*, 29(5), 881-900. <https://doi.org/10.1080/09588221.2015.1069747>
- Inn-Chull, Ch. (2016). Efficacy of an ICALL tutoring system and process-oriented corrective feedback, *Computer Assisted Language Learning*, 29(2), 334-364. <https://doi.org/10.1080/09588221.2014.960941>
- Jurafsky, D., & Martin, J. H. (2000). Word classes and Part-Of-Speech Tagging. Ed. In *Speech and Language Processing*, New Jersey: Prentice Hall.
- Lamy, M.-N., & Hampel, R. (2007). Online communication in language learning and teaching. Houndmills: Palgrave Macmillan. <https://doi.org/10.1057/9780230592681>
- Lee, K. W. (2000). English teachers' barriers to the use of computer-assisted language learning. *The Internet TESL Journal*, 6(12), 1-8.
- Levy, M. (1997). *Computer-assisted language learning: Context and conceptualization*. Oxford: Oxford University Press.
- Marcus, M. P., Santorini, B., & Marcinkiewicz, M. A. (1993). Building a large annotated corpus of English: The Penn tree-bank. *Computational Linguistics*, 19(2), 313-330.
- Matthews, C. (1993). Grammar frameworks in intelligent CALL. *CALICO Journal*, 11(1), 5-27.
- McGlenn, J., & Parrish, A. (2002). Accelerating ESL students' reading progress with accelerated reader. *Reading Horizons*, 42(3), 175-189.
- Mikk, J. (1997). Parts of speech in predicting reading comprehension. *Journal of Quantitative Linguistics*, 4(1-3), 156-163. <https://doi.org/10.1080/09296179708590091>
- Mohammadzadeh, B. (2015). The Application of Pedagogical Stylistics in ELT Literature and Language Teaching Courses. *International Online Journal of Primary Education (IOJPE)*, 4(1), 21-26.
- Murphy, E. (2000). *Strangers in a strange land: Teachers' beliefs about teaching and learning French as a second or foreign language in online learning environments* (pp. 1-356).
- Naba'h, A. A., Hussain, J., Al-Omari, A., & Shdeifat, S. (2009). The effect of computer assisted language learning in teaching English grammar on the achievement of secondary students in Jordan. *Int. Arab J. Inf. Technol.*, 6(4), 431-439.
- Nagata, N. (1996). Computer vs. workbook instruction in second language acquisition. *CALICO Journal*, 14(1), 53-75.
- Nutta, J. (1998). Is computer-based grammar instruction as effective as teacher-directed grammar instruction for teaching L2 structures? *CALICO Journal*, 16(1), 49-62. <https://doi.org/10.1558/cj.v16i1.49-62>
- Önsoy, S. (2004). *Students' and teachers' attitudes towards the use of computer-assisted language learning at the Preparatory School of Celal Bayar University* (Unpublished master's thesis), Bilkent University, Ankara, Turkey.
- Pirasteh, P. (2014). The effectiveness of computer-assisted language learning (CALL) on learning grammar by Iranian EFL learners. *Procedia-Social and Behavioral Sciences*, 98, 1422-1427. <https://doi.org/10.1016/j.sbspro.2014.03.561>
- Richards, J. C., & Rodgers, T. S. (1987). *Approaches and methods in language teaching*. Cambridge: Cambridge University Press.

- Schmidt, R. (2001). Attention. In P. Robinson (Ed.), *Cognition and second language instruction* (pp. 3–32). Cambridge: Cambridge University Press. <https://doi.org/10.1017/CBO9781139524780.003>
- Simpson, P. (1997). *Language through literature: An introduction*. Psychology Press. <https://doi.org/10.4324/9780203279175>
- Stockwell, G. (2007). A review of technology choice for teaching language skills and areas in the CALL literature. *ReCALL*, 19(2), 105–120. <https://doi.org/10.1017/S0958344007000225>
- Toole, J., & Heift, T. (2002). The tutor assistant: An authoring tool for an intelligent language tutoring system. *Computer Assisted Language Learning*, 15(4), 373-386. <https://doi.org/10.1076/call.15.4.373.8266>
- Van Lier, E., & Rijkhoff, J. (2013). *Flexible word classes: A typological study of underspecified parts-of-speech*. Oxford: Oxford University Press.
- Vermunt, J., & Verschaffel, L. (2000). Process-oriented teaching. In R-J. Simons, J. v. d. Linden, & T. Duffy. (Eds.), *New learning* (pp. 209-225). Netherlands: Kluwer Academic. [https://doi.org/10.1007/0-306-47614-2\\_11](https://doi.org/10.1007/0-306-47614-2_11)
- Vulanović, R., & Miller, B. (2010). Grammar Efficiency of Parts-of-Speech Systems. *Glottology*, 3(2), 65-80. <https://doi.org/10.1515/glot-2010-0015>
- Warschauer, M., & Healey, D. (1998). Computers and language learning: an overview. *Language teaching forum*, 31, 57-71. <https://doi.org/10.1017/S0261444800012970>
- Yang, Y. F. (2011). Computer Assisted Language Learning. *College English*, 24, 181-198.

**<http://www.ejmste.com>**

## Compilation of the Scale of College Students' Attitudes towards Three-self-determination PE Class and Norm Construction

Yiyong Wu<sup>1</sup>, Rong Hai Su<sup>2\*</sup>

<sup>1</sup> Business School, Minnan Normal University, Fujian, CHINA

<sup>2</sup> School of Physical Education and Sport, Beijing Normal University, Beijing, CHINA

Received 27 December 2017 • Revised 13 February 2018 • Accepted 25 March 2018

### ABSTRACT

College students' attitudes towards three-self-determination PE class are preceded the theoretical construction and the scale of college students' attitudes towards three-self-determination PE class is compiled by comprehensively applying literatures, discussions, and questionnaire. With Partial Least Squares (PLS) to select information and explore theories, it reveals that college students' attitudes towards three-self-determination PE class are composed of 7 dimensions of attitudes towards course cognition, attitudes towards social behavior, attitudes towards health and safety, attitudes towards leisure life, attitudes towards sports knowledge, attitudes towards sports technique, and attitudes towards physical development; and, the fit of attitude model is favorable. With Structural Equation Modeling (SEM) Confirmatory Factor Analysis, the structure of the scale of college students' attitudes towards three-self-determination PE class is supported, and the scale presents good reliability, validity, and stability. What is more, the national overall, gender, and grade norms are also constructed.

**Keywords:** three-self-determination teaching, PE class, partial least squares, structural equation modeling, norm

### INTRODUCTION

According to the spirit of "National Teaching Guidelines for PE Course at the Level of General Universities and Colleges", three-self-determination PE teaching model thoroughly develops the student-centered and teacher-led functions to promote open instruction and expand the time and space of PE course. Under the guide of teachers, students select the class contents (projects), the instructor, and the time for the class. Wu (2011) took the students in academic years of 2008 and 2009 in 8 general colleges and universities in Fujian Province as the research subjects and received the feedback that 83.6% students regarded the necessity of three-self-determination teaching. Apparently, three-self-determination teaching model was deeply approved by students. In terms of teaching mode, three-self-determination teaching model expands the time and space of PE course, could satisfy most students' requirements for class selection, and is suitable and correct. Nevertheless, has three-self-determination teaching model, which has been practiced since 2002, achieved the expected teaching goal? What are students' attitudes after receiving three-self-determination teaching model? What is the effect of formed attitudes on three-self-determination PE class teaching effectiveness? Such questions should be emphasized in order to better understand the actual effect of three-self-determination PE class teaching model. Regarding attitudes towards PE class, more questionnaire surveys are applied to the measurement. International scales of attitudes towards PE class are basically complied with Wear's Likert, while domestic research on attitudes towards PE class mainly combines the relations with interests, motivation, and behaviors or focuses on descriptive surveys that the research quality needs to be enhanced. From literature review, there has not been a scale of attitudes established aiming at PE class domestically.

### Contribution of this paper to the literature

- Colleges and universities should reinforce the research on the modernization of course establishment, timely assign teachers for learning and study, and establish some emerging PE projects to expand the course establishment, enhance the course novelty, and satisfy students' needs.
- The network of "three-self-determination" course selection should be reinforced to enhance the teaching organization and management. The single assessment model should be changed to stress on the comprehensive evaluation in order to provide larger free space for students.
- Colleges and universities should grasp such an opportunity to enlarge the PE field and facilities and gradually release the contradiction between students' requirement for course establishment and the lag of field and facility construction.

For this reason, in order to understand college students' attitudes towards physical education after receiving three-self-determination PE class and test college three-self-determination teaching model, a reliable and effective scale of college students' attitudes towards three-self-determination PE class is compiled for the reference.

## LITERATURE REVIEW

Since Alden (1932) studied the least attractive factors in female college students' attitudes towards physical education in 1932, research on students' attitudes towards PE class has been broadly concerned. In the 20<sup>th</sup> century before 1940s, research on students' attitudes towards PE class was restricted to questionnaire survey, and there was not a researcher compiling the scale of attitudes towards PE class. Not until 1945, when Carr (1945) compiled the first scale of attitudes towards physical education with interval scale, or Thurstone Scale, did foreign researchers started the research on and application to the scale of attitudes towards PE class.

Reviewing domestic and international research on students' attitudes towards PE class, most research revealed that students approved or presented active attitudes towards PE class, supported the social, affective, and physical value of PE class to students, and improved the attitudes towards physical education taking PE course. Particularly, in the 20<sup>th</sup> century after 1990s, attitudes showed the critical role in the research on PE teaching, mainly because attitudes were the key factor in adolescents participating in PE activity.

In regard to the measurement of attitudes, which cannot be directly measured, domestic and international researchers mainly measured students' attitudes towards PE class indirectly, e.g. personal interview, questionnaires, evaluation method, and project method, where questionnaires were mostly applied to measure students' attitudes towards PE class. Regarding the types of attitude scales, current application of attitude scales contains Thurstone scale (or interval scale), Likert scale (or summated scale), and Guttman scale (or cumulative scale), where Likert scale, with the advantages of broader measurement and application, simpler measurement practice, better conforming to the requirement for reliability, and more delicate and deeper measurement, is favored by domestic and international researchers. Domestic and international researchers present different aspects on the structure of students' attitudes towards PE class. Most researchers discussed attitude structure with social psychology and considered that attitudes were composed of cognition, affection, and behavioral intention. Other researchers studied attitude structure from the aspect of Theory of Reasoned Action and regarded past behaviors and experiences as the key factors in attitudes. Some researchers directly applied the structure of attitudes towards physical education to the evaluation of students' attitudes towards PE class. A lot of researchers took the elements of PE teaching, e.g. teachers, class contents, teaching climate, and teaching goal, into the account of attitude structure.

No matter which measurement is applied, which type of scale is applied, and what the structure of scale is, the quality of test tools should be guaranteed, as it could directly affect the description or inference of research results. As a matter of fact, research methods on sports science were emphasized after 2000; especially, the popularity of Structural Equation Modeling (SEM) had the scale compilation process become stricter. The overall reliability and validity of the scale of students' attitudes towards PE class were also enhanced. From the development of the scale of attitudes towards PE class in the past 86 years, the research on attitudes towards PE class has developed from borrowing the scale of research on attitudes towards physical education to general research on attitudes towards PE class and would develop to the research on attitudes with PE class teaching characteristics. Based on the understanding and above descriptions, Likert scale is utilized in this study. Based on the attitude theory in social psychology and combined with the statement of college three-self-determination PE class teaching goals, the scale of attitudes towards college three-self-determination PE class is compiled for analyzing the reliability and validity and establishing the norm.



## PRETEST OF THE SCALE OF ATTITUDES TOWARDS THREE-SELF-DETERMINATION PE CLASS

### Pretest Subject

With group sampling, colleges and universities with three-self-determination physical education are distributed the pretest scale, including Peking University, Sichuan University, Shenzhen University, Northeast Normal University, Northwestern Polytechnical University, and Southeast University. Total 508 copies of questionnaire are distributed. Respondents who have never taken three-self-determination PE class and invalid copies of questionnaire are removed to make total 489 valid copies, with the effective retrieval rate 96.3%, including 221 males (45.2%) and 286 females (54.8%), 115 freshmen, 118 sophomores, 126 juniors, and 130 seniors, as well as 286 from countryside and 203 from cities. The sample representativeness is favorable.

### Pretest Analysis

Partial Least Squares (PLS), first proposed by Wold (1975) for econometric analysis but emphasized and popular in chemometry, is commonly used in management, marketing, and psychology. PLS defines a component structure with the linear integration of variables and, with regression principle, to explain and test the prediction and explanation among components that it is called Component-Based Structural Equation Modeling. PLS aims to acquire the maximum prediction among components. Components in the model are not the same as the properties of psychological dimension that the variable allocation is not restricted by normal assumptions that it is called soft modeling. PLS is suitable for solving the prediction of variables and exploring the theoretical model that it is utilized in this study for selecting the information in the pretest scale and exploring the attitude model.

### Result and Analysis of Pretest Scale

Combining domestic and international research and experts' opinions with the teaching situations and characteristics of college three-self-determination PE class as well as college students' reflection to PE effect, 7 domestic college students' three-self-determination PE class teaching goals are confirmed, covering course cognition, social behaviors, health and safety, leisure life, sports knowledge, sports techniques, and physical development. Total 29 questions related to domestic college students' attitudes towards three-self-determination PE class are compiled for the 7-point simplified scale. It contains 6 questions about attitudes towards course cognition, 4 questions about attitudes towards social behaviors, 8 questions about attitudes towards health and safety, 2 questions about attitudes towards leisure life, 3 questions about attitudes towards sports knowledge, 3 questions about attitudes towards sports technique, and 3 questions about attitudes towards physical development. The research variables are reflective indices; questions with the same or similar contents present exchangeability; and, questions without changing the idea of dimensions are removed. Fornell and Larcker (1981) suggested the structural validity with the factor loadings  $>.70$ . In this case, the data analyses show that the factor loadings of T1, T2, T4, K3, and SK1 in the pretest scale do not achieve the standard  $.70$  that they are removed. The rest questions present the factor loadings in  $.74\sim.95$ , larger than  $.70$ , the composite reliability in  $.93\sim.97$ , larger than  $.70$ , the average of variance extracted in  $.77\sim.8$ , larger than  $.50$ , and the Cronbach's  $\alpha$  in  $.82\sim.96$ , larger than  $.70$ , reaching the ideal standards. It reveals favorable reliability and convergent validity after removing 7 questions not achieving the standard. As a result, they should be remained. The square roots of AVE of variables appears in  $.88\sim.95$ , larger than the standardized correlation coefficients of other variables, showing better discriminant validity among dimensions. The constructed PLS attitude model GOF =  $.76$  is higher than  $.36$ , revealing the good fit of attitude model with the 7 dimensions. The pretest scale of attitudes towards three-self-determination PE class passes the exploratory analysis that confirmatory analysis could be further preceded.

## FORMAL TEST OF THE SCALE OF ATTITUDES TOWARDS THREE-SELF-DETERMINATION PE CLASS

### Test Subject

Total 2500 college students in Tsinghua University, Harbin Institute of Technology, Shanghai Jiao Tong University, Southeast University, Xiamen University, Shenzhen University, Sichuan University, Hunan Agricultural University, Chongqing Jiaotong University, Guangxi Normal University, Northwestern Polytechnical University, and Lanzhou University are classified, sampled, and tested. Total 2487 copies of questionnaire are retrieved, and 45 invalid copies are removed to make the effective 2442 copies. The valid samples are listed in [Table](#)

**Table 1.** Analysis of demographic characteristics

Variable	Group	No. of Times	Percentage	Variable	Group	No. of Times	Percentage
Sports item	Football	178	7.3	Gender	Male	1175	48.1
	Basketball	229	9.4		Female	1267	51.9
	Volleyball	212	8.7	Grade	First grade	595	24.4
	Tennis	142	5.8		Second grade	611	25.0
	Badminton	186	7.6		Third grade	622	25.5
	Table tennis	125	5.1		Fourth grade	614	25.1
	Soccer	93	3.8	Origin	Countryside	1119	45.8
	Cricket	68	2.8		City	1323	54.2
	Swimming	149	6.1	Distribution of university	Northeast	2	10.0
	Martial art	127	5.2		North China	4	20.0
	Tai Chi	120	4.9		East China	4	20.0
	Taekwondo	181	7.4		South China	3	15.0
	Rhythmic gymnastics	212	8.7		Central China	2	10.0
	Shape	201	8.2		Southwest	2	10.0
	Others	219	9.0	Northwest	3	15.0	

1. The sampled colleges and universities are broadly distributed, including 2 in northeast, 4 in north China, 4 in east China, 3 in south China, 2 in central China, 2 in southwest, and 3 in south east.

### Statistical Analysis

Confirmatory Factor Analysis (CFA) is an important part of SEM (Structural Equation Modeling). The reduction of variables for CFA is revised from Kline's (2010) two-order model. The measurement model should be tested before evaluating the structure model. The complete SEM report could be preceded when the measurement of the fit of model is acceptable. SEM, as the technological integration of structure covariance, could develop and test the model and compare the fit of the opposition model and data generated from theories. As a result, it is suitable to precede SEM Confirmatory Factor Analysis and evaluate the fit of model structure with AMOS.

### Result and Analysis of Formal Test

#### *Reliability and validity*

With Factor Analysis, the factor loadings of all dimensions appear in .69~.93, including "attitudes towards course cognition" (average variance extracted=0.64,  $\alpha=0.83$ ), "attitudes towards social behavior" (average variance extracted=0.75,  $\alpha=0.92$ ), "attitudes towards health and safety" (average variance extracted=0.69,  $\alpha=0.95$ ), "attitudes towards physical development" (average variance extracted=0.81,  $\alpha=0.93$ ), "attitudes towards sports knowledge" (average variance extracted=0.58,  $\alpha=0.73$ ), "attitudes towards sports technique" (average variance extracted=0.74,  $\alpha=0.85$ ), and "attitudes towards leisure life" (average variance extracted=0.75,  $\alpha=0.86$ ).

#### *Discriminant validity of form scale*

The results are shown in Table 2. The square roots of AVE of dimensions on the diagonal are larger than the standardized correlation coefficients beyond the diagonal that there is discriminant validity among the 7 dimensions.

**Table 2.** Discriminant validity analysis of formal scale

	<b>Cognition goal</b>	<b>Social behaviors goal</b>	<b>Health and safety goal</b>	<b>Leisure life goal</b>	<b>Sports knowledge goal</b>	<b>Sports techniques goal</b>	<b>Physical goal</b>
Cognition goal	<b>.80</b>						
Social behaviors goal	-.15	<b>.87</b>					
Health and safety goal	-.26	.81	<b>.83</b>				
Leisure life goal	-.22	.72	.83	<b>.87</b>			
Sports knowledge goal	-.08	.67	.71	.69	<b>.76</b>		
Sports techniques goal	-.10	.64	.69	.70	.67	<b>.86</b>	
Physical goal	-.13	.71	.78	.76	.66	.76	<b>.84</b>

Note: The bold on the diagonal is the square roots of AVE, lower triangle is the Pearson correlation of factors

**Table 3.** Fit indices of attitude model

<b>Fit indices</b>	<b>Allowable range</b>	<b>Fit</b>	<b>Model fit judgment</b>
Chi-square		386.55	
Degree of freedom		245	
CFI	>.9	.98	pass
RMSEA	<.08	.07	pass
TLI	>.9	.98	pass
GFI	>.9	.96	pass
NFI	>.9	.96	pass
$\chi^2/df$	<3	1.58	pass
AGFI	>.8	.95	pass

### *Test of attitude model*

Since SEM samples more than 200 could easily result in large chi-square value to cause bad fit, the fit needs to be modified with Bootstrap. The modified fit of model is shown in [Table 3](#), from which the fit indices pass the standards, showing the acceptability of the attitude model.

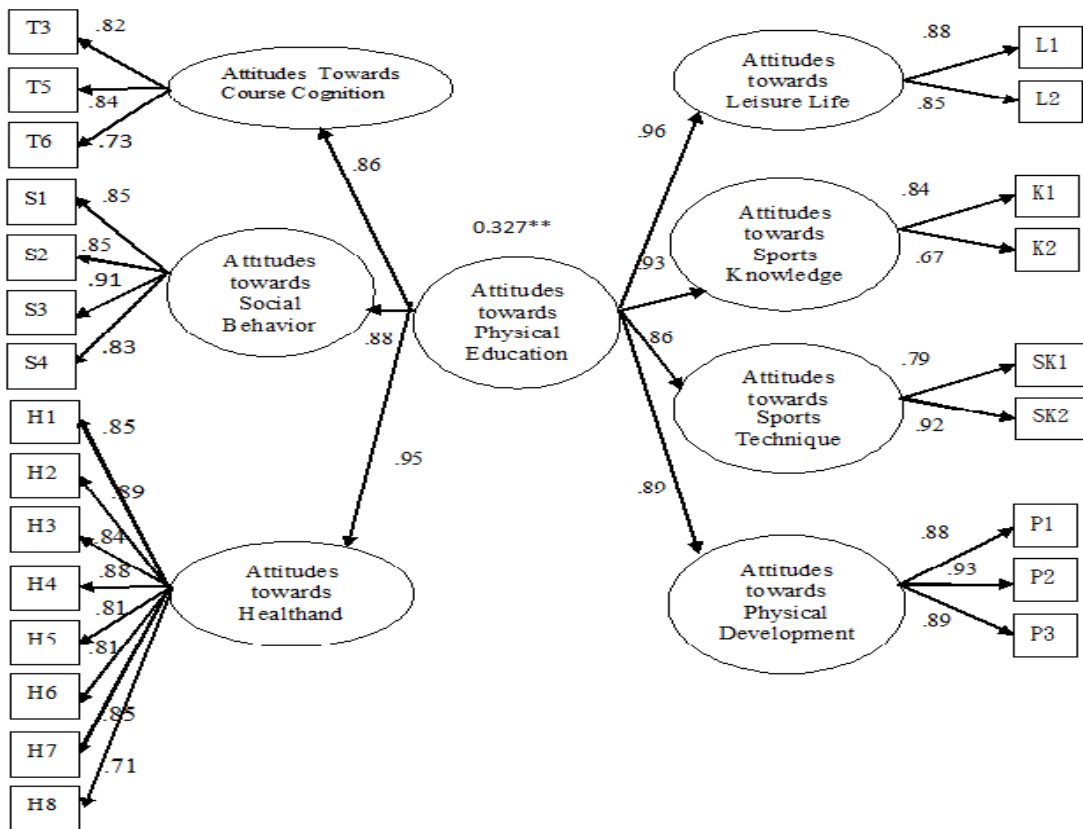


Figure 1. AMOS attitude model

Table 4. Cross validation data organization

Model	$\chi^2$	Df	$\Delta df$	$\Delta\chi^2$	P
Factor loadings	14.97	17			.60
Structure coefficient	25.92	23	6	10.95	.30
Structure covariance	28.16	24	1	2.24	.25

### Cross validation test

The samples are randomly divided into two groups to test the cross validation of the attitude model, containing the factor loadings, structure coefficient, and structure covariance of the measurement model. The model presents stability when there is no difference between the two sample groups. The results, Table 4, conform to the mild test, the data in two groups are homogeneous, and the two groups are equivalent, revealing no difference between two groups. The two groups present cross validation, and the attitude model shows stability.

### Sample estimation and statistical test

RMSEA is used in this study for sampling, and the sample value is calculated according to the degree of freedom 245 to make the minimum samples above 108. There are 2442 effective samples in this study, conforming to the requirement. The statistical test is better higher than .8, and the statistical test of this study is 1, showing good statistical test of this study.

**Table 5.** Multivariate Analysis of Variance of gender and grade in attitudes towards three-self-determination PE class

Factor	Gender			Grade			Gender × Grade		
	SS	df	F	SS	df	F	SS	df	F
Attitudes towards course cognition	13.99	1	6.14*	4.85	3	2.13	7.42	3	3.25*
Attitudes towards social behavior	.15	1	.12	2.52	3	2.10	1.06	3	.88
Attitudes towards health and safety	.00	1	.00	3.32	3	3.26*	1.40	3	1.38
Attitudes towards leisure life	3.79	1	3.02	4.32	3	3.44*	1.91	3	1.52
Attitudes towards sports knowledge	.15	1	.12	3.47	3	2.70*	1.76	3	1.37
Attitudes towards sports technique	.36	1	.25	3.33	3	2.33	2.26	3	1.58
Attitudes towards physical development	.53	1	.44	2.03	3	1.69	1.53	3	1.27

\* stands for P<.1

**Table 6.** National norms of college students' attitudes towards three-self-determination PE class

Type of norm	Attitudes towards Course Cognition	Attitudes towards Social Behavior	Attitudes towards Health And Safety	Attitudes towards Leisure Life	Attitudes towards Sports Knowledge	Attitudes towards Sports Technique	Attitudes towards Physical Development	
Overall	4.66±1.53	4.47±1.10	4.58±1.02	4.55±1.13	4.33±1.14	4.28±1.20	4.43±1.10	
Gender	Male	4.46±1.52	4.40±1.16	4.54±1.05	4.43±1.16	4.31±1.16	4.23±1.20	4.37±1.10
	Female	4.83±1.52	4.55±1.04	4.63±.97	4.67±1.09	4.36±1.12	4.34±1.19	4.50±1.09
Grade	First	4.16±1.75	4.62±1.75	4.73±1.09	4.69±1.17	4.59±1.20	4.50±1.36	4.61±1.19
	Second	4.87±1.45	4.57±1.45	4.69±.86	4.73±1.01	4.31±1.08	4.28±1.14	4.44±.96
	Third	4.59±1.50	4.50±1.50	4.57±.99	4.48±1.21	4.25±1.08	4.18±1.15	4.37±1.17
	Fourth	4.54±1.36	4.20±1.36	4.33±1.06	4.30±1.09	4.18±1.14	4.18±1.10	4.33±1.03

## NORMS OF COLLEGE STUDENTS' ATTITUDES TOWARDS THREE-SELF-DETERMINATION PE CLASS

### Sample Distribution

The normative samples, with formal test, appear 2442 valid copies and 812 valid copies acquired from the successive survey to make the total 3254 copies (samples are acquired from the previous 20 colleges and universities as well as 5 non-985 and 211 colleges and universities of Beijing Normal University (Zhuhai), Minnan Normal University, Anyang Institute of Technology, Ezhou Polytechnic, and Huanggang Normal College). The specific distribution shows 1676 females and 1578 males, 793 freshmen, 825 sophomores, 831 juniors, and 805 seniors, as well as 1566 from countryside and 1688 from cities. The sample representativeness is strong.

### Norm Establishment of College Students' Attitudes towards Three-Self-Determination PE Class

Taking gender and grade as the arguments, the factors of attitudes towards three-self-determination PE class is evenly divided for Multivariate Analysis of Variance (MANOVA), **Table 5**. The results show significant differences in gender of the even division of attitudes towards course cognition, remarkable differences in grade of the even division of attitudes towards health and safety, attitudes towards leisure life, and attitudes towards sports knowledge, as well as notable interaction of gender×grade of the even distribution of attitudes towards course cognition. The multiple comparisons and simple effect test present that females appear higher attitudes towards course cognition than males; and, attitudes towards health and safety, attitudes towards leisure life, and attitudes towards sports knowledge decrease with increasing grade. The overall, gender, and grade norms of college students' attitudes towards three attitudes self-determination PE class are established from above analyses.

### Norm of College Students' Attitudes towards Three-Self-Determination PE Class

**Table 6** shows the overall norm, gender norm, and grade norm of college students' attitudes towards three-self-determination PE class.

## DISCUSSION

College three-self-determination PE class is the final stage of school physical education as well as the final opportunities for college students learning lifelong physical education and maintaining physical health before entering the society from the school system. For this reason, compiling the scale cutting in from college three-self-determination PE class teaching goals to understand college students' attitudes towards three-self-determination PE class and acquire the three-self-determination PE class teaching effect present the significant meaning for the complete college three-self-determination PE class teaching. It is also related to students' lifelong training and health and the key factor in the productivity of the nation and society and the expenditure of medical funds.

From college PE class teaching goals proposed under "National Teaching Guidelines for PE Course at the Level of General Universities and Colleges" issued by Ministry of Education, college PE class should achieve 5 goals of sports participation, sports skills, physical health, psychological health, and social adaptation. Some domestic researchers considered that college PE teaching goals should cover physical fitness, sports skills, knowledge of physical and health theories, and learning attitudes. Furthermore, domestic researchers also surveyed college students' PE class. For instance, Yeh (1994) indicated that ideal PE teaching goals should contain the cultivation of sports techniques, the training of physical fitness, the cultivation of social behaviors, the learning of professional sports knowledge, and the acquisition of sports fun. Tsai, Lin, and Liu (1998) discovered that college students' top PE class teaching goals contained the enhancement of personal health, the acquisition of physical and mental balanced development, the release of pressure, the establishment of sports habits, and the promotion of leisure life. Yang et al. (1994) pointed out the order of PE teaching goals approved by college students as the acquisition of health, the cultivation of sports habits, and the training of basic physical fitness. From above literatures, the statements of PE teaching goals from Ministry of Education, domestic researchers, and college students are distinct, but the basic agreement with PE teaching goals is consistent. The 7 major attitude structures in the scale cover above points of view that the 7 major dimensions are reasonable and present good structural validity.

Domestic research on scale compilation used to apply Exploratory Factor Analysis (EFA), but little utilize Structural Equation Modeling (SEM) for Confirmatory Factor Analysis (CFA) so that the consistency between the theoretical model and the actual data could not be effectively explored and verified; and, the cross-sample application stability of the scale cannot be tested. PLS (Partial Least Squares) is applied in this study to explore college students' attitudes towards three-self-determination PE class model. Information is selected from the pretest scale and SEM is utilized for Confirmatory Factor Analysis and testing the fit of attitude model that it is a new attempt for the reference of future researchers. From the attitude model explored with PLS, T1, T2, T4, K3, and SK1, which do not reach the factor loadings, are removed and the fit of attitude model  $GOF=.76$  achieves the better standard. From SEM Confirmatory Factor Analysis and the test result of attitude model, all dimensions in the scale appear the factor loadings in .69~.93, the composite reliability (CR) in .73~.95, the average of variance extracted (AVE) in .58~.81, and the square root of AVE larger than the standardized correlation coefficients of various dimensions, explaining the good reliability and validity of the scale. The fit indices of attitude model pass the standards, revealing the acceptability of the attitude model which could be used for explaining the actual observed data. What is more, the attitude model passes the cross validation test, showing the cross-sample application stability of the scale. Based on above analyses, the college students' attitudes towards three-self-determination PE class simplified scale containing 7 major factors and 24 observation questions are eventually acquired.

From the national norm of college students' attitudes towards three-self-determination PE class, the average of college students' attitudes towards three-self-determination PE class is 4.50, and the overall evaluation of three-self-determination PE class is above the general standard, which are consistent with the past research results. Females present higher overall evaluation on college three-self-determination PE class and the evaluation of dimensions, and college students' overall evaluation and evaluation of dimensions of three-self-determination PE class reduce with increasing grade. It is possibly because females show stronger motivation on the participation in three-self-determination PE class; the higher class participation results in higher female evaluation. College students generally would complete three-self-determination PE class before being seniors that it is normal for the attitude evaluation decreasing with increasing grade.

## SUGGESTION

A lot of domestic colleges and universities have established the PE course system "with the three-self-determination elective course as the body, the required course as the basis, the extra-curricular training as the supplement, and the competition training as the expansion" for the theoretical and practical innovation and breakthrough of college PE course systems. In this case, research on college students' attitudes towards three-self-determination PE class becomes primary. PLS (Partial Least Squares) is applied in this study to explore college students' attitudes towards three-self-determination PE class model and SEM is used for Confirmatory Factor Analysis and testing the fit of attitude model to eventually acquire college students' attitudes towards three-self-



determination PE class simplified scale with good reliability and validity. The scale contains 7 major factors and 24 observation questions. It could be directly used for the measurement of college students' attitudes towards three-self-determination PE class. From the national norm of college students' attitudes towards three-self-determination PE class, the evaluation of three-self-determination PE class is above the general standard. It could be enhanced from the following directions.

- (1) Colleges and universities should reinforce the research on the modernization of course establishment, timely assign teachers for learning and study, and establish some emerging PE projects to expand the course establishment, enhance the course novelty, and satisfy students' needs. Meanwhile, "three-self-determination" PE class should be reinforced the material construction. Particularly, the reinforcement of the research on and compilation of teaching outlines and teaching plans is the premise to guarantee the teaching quality.
- (2) Teachers should be aware of the adjustment of the knowledge structure, expand the knowledge, reinforce the theory learning and business study, enhance the professional standards, and accurately find out the direction. Meanwhile, the network of "three-self-determination" course selection should be reinforced to enhance the teaching organization and management. The single assessment model should be changed to stress on the comprehensive evaluation in order to provide larger free space for students.
- (3) With the great development in past years, domestic colleges and universities have established certain economic bases and presented the ability to improve and expand existing field and facilities. Colleges and universities should grasp such an opportunity to enlarge the PE field and facilities and gradually release the contradiction between students' requirement for course establishment and the lag of field and facility construction.

### ACKNOWLEDGEMENTS

1. Fujian Province Education Department (Fujian higher education, No: 44, 2017), College of Applied Discipline construction field: Applied Economics application-oriented discipline cultivation project.
2. Fujian Provincial Education Department (Fujian education subject, No: 115, 2017), "Business Big data analysis and application of Fujian University key Laboratory" construction project.

### REFERENCES

- Alden, M. A. (1932). The Factors in the Required Physical Education Program that are Least Attractive to the College Girl. *Research Quarterly for Exercise and Sport*, 3(4), 97-107.
- Carr, M. G. (1945). The Relationship between Success in Physical Education and Selected Attitudes Expressed by High School Freshmen Girls. *Research Quarterly for Exercise and Sport*, 16(3), 176-191.
- Fornell, C., & Larcker, D. F. (1981). Evaluating structural equation models with unobservable variables and measurement error. *Journal of Marketing Research*, 18(1), 39-50. <https://doi.org/10.2307/3151312>
- Kline, R. B. (2010). Principles and practice of structural equation modeling. *Journal of the American Statistical Association*, 101(12), 354-361.
- Tsai, C.-B., Lin, L.-J., & Liu, Y.-R. (1998). National Cheng Kung University PE course needs evaluation and survey. *NCKU PE research collection*, (4), 61-84.
- Wold, H. (1975). Soft modelling by latent variables: the non-linear iterative partial least squares (NIPALS) approach. *Perspectives in Probability and Statistics*, 117-142. <https://doi.org/10.1017/S0021900200047604>
- Wu, S.-S. (2011). A study on the practice of "three-self-determination" teaching model in PE course of universities in Fujian Province. *Shandong Sports Science & Technology*, 33(6), 70-72.
- Yang, Z.-X., Chen, T.-C., Chen, H.-Y., Wu, H.-Y., Lan, B.-Y., Wang, J.-L., Liu, L.-Y., & Chen, Q.-C. (1994). Opinion survey of the practice of university PE course. *Sports & Exercise Research*, (18), 95-101.
- Yeh, X.-Q. (1994). PE teaching goal and content. *National Sports Quarterly*, 23(4), 63-70.

## APPENDIX

## College Students' Attitudes towards Three-Self-Determination PE Class Simplified Scale

Factor	Serial no.	Question	Remark
Attitudes towards course cognition	T1	Three-self-determination PE class is more effective than traditional PE class.	
	T2	Complete college PE teaching should contain three-self-determination PE teaching.	
	T3	Physical training opportunities are adequate in daily life and learning that three-self-determination PE class is not necessary.	
	T4	Modern education trend points out the necessity of college three-self-determination PE class teaching.	revised
	T5	Merely interested items are opened in PE required course, but not three-self-determination PE class.	
	T6	I would participate because three-self-determination PE class is a required credit.	
Attitudes towards social behavior	S1	Three-self-determination PE class could provide actual teaching situations to develop sports spirit.	revised
	S2	Three-self-determination PE class could help develop good social behaviors.	
	S3	Three-self-determination PE class could train the brave, determined, and agile spirits.	
	S4	Three-self-determination PE class allows learning tolerance and obedience.	
Attitudes towards health and safety	H1	Three-self-determination PE class could result in satisfactory and pleasant feelings.	
	H2	Three-self-determination PE class could inspire me to present self-confidence.	
	H3	Three-self-determination PE class could let me relax.	
	H4	Three-self-determination PE class is important to my physical training.	
	H5	Three-self-determination PE class allows me understanding the importance of sports to health.	revised
	H6	Self-selected three-self-determination PE class could enhance self-confidence.	revised
	H7	Three-self-determination PE class could help develop good figure.	
	H8	Three-self-determination PE class could enhance the health of physically weak students.	revised
Attitudes towards leisure life	L1	The teaching effect of three-self-determination PE class could have my life be more pleasant.	
	L2	Sports skills cultivated in three-self-determination PE class is valuable for the sports life after graduation.	revised
Attitudes towards sports knowledge	K1	Three-self-determination PE class shows explanations about the specific knowledge and rules of acquired sports projects.	
	K2	Sports items learned in three-self-determination in PE class allow me becoming a professional sport audience.	revised
	K3	Mental activity (sports rules, PE theories) is not necessary for three-self-determination PE class.	
Attitudes towards sports technique	SK1	The participation of three-self-determination PE class merely trains techniques, but not mind (sports rules, PE theories)	
	SK2	The participation in three-self-determination PE class allows me being familiar with the interested sports projects.	revised
	SK3	Three-self-determination PE class could help improve sports techniques.	
Attitudes towards physical development	P1	The participation in three-self-determination PE class allows me showing more flexible responses to accidents.	
	P2	The participation in three-self-determination PE class allows me engaging in learning and living in daily life with enough strength and endurance.	revised
	P3	Three-self-determination PE class presents great help on the flexibility of personal responses.	

<http://www.ejmste.com>

# Effects of Social and Emotional Learning on Disadvantaged Year 1 Pupils' Understanding of Sinking and Floating Concepts

Ang Sze Wei<sup>1</sup>, Mageswary Karpudewan<sup>1\*</sup>

<sup>1</sup> School of Educational Studies, Universiti Sains Malaysia, Penang, MALAYSIA

Received 30 September 2017 • Revised 21 February 2018 • Accepted 26 March 2018

## ABSTRACT

The purpose of this qualitative case study was to explore Year 1 pupils' understanding about sinking and floating after learning using *Social and Emotional Learning (SEL)* strategies. A total of 16 Year 1 pupils of low socio-economic background from one class in a rural school participated in this study. The participants were from disadvantaged rural communities; single parents and two pupils were identified with medical problems (thalassemia and mild autism). In this study, three lessons on sinking and floating were imparted using *SEL* strategies. Data from three sources; worksheets, interviews and observations were triangulated to cross validate the data and to capture richer information to answer the research question. The triangulation of the findings indicates that *SEL* strategies created a conducive learning environment; reduced disruptive behaviors among the pupils; encouraged engagement and participation in learning. In sum *SEL* strategies employed to teach sinking and floating resulted in the pupils having a better understanding of these concepts. The research findings imply that ability in managing social and emotional tendency improved their competency particularly in learning abstract science concepts such as sinking and floating.

**Keywords:** disadvantaged pupils, sinking and floating, social and emotional learning, rural school, year 1 pupils

## INTRODUCTION

*Social and Emotional Learning (SEL)* is rapidly gaining the attention of many educators world-wide (Durlak, Weissberg, Dymnicki, Taylor, & Schellinger, 2011). Three reviews involving 371 students revealed that *SEL* produced various benefits including improved academic achievements across kindergarten to grade eight students (Payton et al., 2008). For the purpose of this study, a set of teaching strategies based on *SEL* principles aimed at establishing a positive relationship among the learning communities, and establishing an encouraging learning environment with reduced challenging behaviors were designed. These teaching strategies were employed to teach sinking and floating concepts to the Year 1 students from disadvantaged rural communities. In this qualitative study, how students developed their understanding of sinking and floating will be reported.

## THEORETICAL BACKGROUND

### Social and Emotional Learning (SEL)

In the classroom context, an individual's thinking is developed during the social interaction between students and the teacher and between peers (Vygostky, 1978). Lessons based on social constructivist perspectives designed using mobile devices have supported students' learning (Krajcik & Delen, 2017). An inquiry-based socio-constructivist model of shadow formation implemented in a French context involving pre-schoolers contributed to the children's understanding of shadow formation (Impedovo, Delserieys-Pedregosa, Jegou & Ravanis, 2017). STEM education implemented in many countries using various approaches shown to support students' learning (Tippett & Milford, 2017). Social interaction is one of the imperative dimensions of STEM education. Findings of

### Contribution of this paper to the literature

- This study exhibits one of the initial examples on the introduction of Social and Emotional Learning approach in teaching science concepts among less disadvantaged Year 1 pupils.
- Up to this end, there is no study, particularly reported on the effectiveness of Social and Emotional Learning Approach in learning science concepts. As such the findings of the study bridge this gap.
- This study suggests how less disadvantaged students able to learn difficult science concepts when they manage to take control of their behaviors and emotions.
- The findings of this study also suggest that the ordinary teaching strategies used in a normal classroom are not appropriate to teach less privileged students with behavioral problems.

these studies elaborated that the interactions during the lessons emotionally supported involvement and engagement of the students in the lessons. The findings from a neuroscience study suggested that there is a direct link between emotions and learning. This is because the emotional centers of the brain are intricately interwoven with the neocortical areas involved in cognitive learning. Fler (2013) investigated the influences of the affective components (the emotional aspects) on science learning in early years and a study by Tomas and Ritchie (2012) confirmed Fler's findings and reported that Year 12 students' positive emotions encouraged learning about socio-scientific issues.

A study reported academic performance of students increased up to 11 to 17 percentile points with the implementation of SEL programs. SEL programs also showed a significant effect on Chilean 3<sup>rd</sup> and 4<sup>th</sup> graders' academic success (Berger, Alcalay, Torretti & Milicic, 2011). Remarkable improvement in understanding of maths and reading among the low-income kindergarten students and first graders following teaching using SEL programs was explained using the classroom emotional support obtained from the intervention (McCormick, Cappella, O'Connor & McClowry, 2015).

The above literature indicates that when the students were taught on how to manage their feelings and emotion, results in better control of their behaviors particularly the behaviors expressed in the social context such as in classroom learning. Having better control of the behaviors is particularly important for learning abstract science concepts (i.e., sinking and floating). In contemporary various SEL programs have been implemented and students' overall academic performance was measured. More specific studies were conducted in maths and reading. However, to the best of our knowledge, there is no study that has reported on the influence of SEL programs on an understanding of abstract science concepts at an early stage of schooling, especially involving students from the rural school with low socioeconomic backgrounds. For the purpose of this study, SEL strategies were used to teach sinking and floating concepts to Year 1 students. These students were from a rural and low performing school of low socioeconomic background. By the introduction of SEL strategies, Year 1 students' understanding of sinking and floating was explored.

SEL is a process in which students work collaboratively building skills, values and attitude and ability to manage their emotions better to understand each other in the group. These developments enable students to adapt to complex demands of schooling and learning and to successfully manage their learning (Zins & Elias, 2007). Particularly, for elementary school children living in disadvantaged urban communities the ability to manage emotions and understand others have an impact on their academic achievement as these competencies are the foundation for the students to perform at an optimum level (Schonfeld et al., 2015). Schonfeld et al. (2015) further listed three main reasons for SEL interventions being effective in improving academic outcomes. These include SEL interventions that teach children to solve problems (identify problems, set goals, generate solutions and evaluate the outcomes), encourage student-teacher relationships in which more opportunity is provided to interact in the classroom and engage in the learning, and with the SEL intervention the classroom will be better managed with less destructive behaviors that enable teachers to deliver complete and effective instructions.

Based on the reasons above various SEL interventions have successfully resulted in improved learning outcomes. For example, *Providing Alternative Thinking Strategies (PATHS)* is a SEL program for elementary students from kindergarten to grade six employed to bridge the cognitive, academic and socio-emotional development using a set curriculum (Fishbein et al., 2016). Increased emotional awareness, being more socially competent, improved behavior adjustment including reducing destructive behaviors that are derived from the implementation of PATHS collectively explain the program's efficiency in improving academic achievement (Greenberg & Kusche, 1998). Lessons include instructions that permit children in identifying, labeling, assessing and managing feelings, controlling impulse and reducing stress, using steps for problem-solving and decision making and having non-verbal and verbal communication skills (Goleman, 1995). These lessons were performed using dialoguing, role-playing, story-telling and modeling (Kelly, Longbottom, Potts & Williamson, 2004). Improved academic achievement in the PATHS classroom could be explained using the affect-behavior-cognitive-dynamic (ABCD) model on which the PATHS curriculum was based (Greenberg & Kusche, 1998). The model works on the premise

that children's emotional development occurs first prior to the behavioral and cognition aspects (Kam, Greenberg & Kusche, 2004). Emotion developed during the maturation stage is verbalized in the form of behavior and cognition at later stages. Major development of cognitive processing skills occurs between the ages 5 to 10 years. During this phase developmental integrations among affect, behavior and cognition influences the social and emotional formation and ultimately academic achievement (Honess & Hunter, 2014).

Another example of the *SEL* approach is called the *Responsive Classroom (RC)*. *RC* is an approach that focuses on promoting both social and academic learning (Rimm-Kaufman & McTigue, 2011). Similar to other *SEL* interventions, *RC* is also based on the principle of developing positive relationships in the classroom and using appropriate approaches to cultivate learning. Implementation of *RC* during third, fourth and fifth grades reported improving academic performance (Brock, Nishida, Chiong, Grimm, & Rimm-Kaufman, 2008). Specifically, *RC* improved both reading (Koslin, Koslin, Zeno, & Ivens, 1989) and maths. The improved reading skills and improvement in maths resulted from the positive classroom learning environment created by *RC* and the activities used. For instance, morning meetings allowed the classroom to be better managed. The practice of greeting every student by name allowed the students to communicate and share in low-stress settings; the group activity encouraged active participation and build class identity and morning messages delivered by the teacher provided a transition to the academic context and aroused interest for the learning.

Studies have found that it is common for children to exhibit behavioral problems and the problems are exacerbated among children from low-income families and children with disabilities (Qi & Kaiser, 2003). A multi-tiered intervention model "Teaching Pyramid" was implemented with the intention to educate the pre-schoolers to identify and manage their problems (Fox, Dunlap, Hemmeter, Joseph & Strain, 2003). The model had reported supporting preschoolers' development of social-emotional competence, reduced challenging behavioral problems and improved their learning (Hemmeter, Ostrosky & Fox, 2006). Similar to *RC* and *PATHS*, the Teaching Pyramid model is also fundamentally based on the principle establishing positive relationships among the children and providing an environment that encourages learning with fewer behavioral problems. With positive social skills, it is expected that the children will be able to manage their emotions and better understand others. This ultimately will result in the effective execution of any program (Hemmeter et al., 2006).

## Sinking and Floating

Sinking and floating are one of the most broadly studied topics in lower primary education (Kallery, 2015). Concepts associated with sinking and floating are the density of materials, buoyancy, water displacement and Archimedes' Principle. Understanding about density is required to understand the concept of buoyancy. Studies have revealed that the concept of buoyancy and density are too difficult for young pupils to comprehend (Kallery, 2015). In another study, Lehrer et al. (2001) found that young pupils failed to differentiate between weight and density. Some studies (e.g., Butts, Hofman, & Anderson, 1993) reported that young pupils' explanations about sinking and floating often focus on a single dimension and relate an object's sinking or floating to its size or its weight. Due to these reasons, pupils in most classrooms were found to hold alternative conceptions of floating (Biddulph & Osborne, 1984). Hsin and Wu (2011) suggested that the use of 'material kind,' rather than introducing the definition of density would be more helpful for the student to understand. This is because in relating the object to the material, pupils would be able to reason and explain the phenomena better (Hardy, Jonen, Möller, & Stern, 2006).

Havu-Nuutinen (2005) conducted a study to observe the process of conceptual change of pupils about sinking and floating. The study employed inquiry and collaborative learning to help pre-kindergarten to second-grade students to develop the concepts of sinking and floating. A study reported that all children were able to explain the objects' behavior in water by relating to the properties of the objects in the post-interviews. This showed that social interaction and knowledge was collaboratively constructed during the inquiry and collaborative learning processes.

More recently, Hsin and Wu (2011) carried out a study to examine young children's explanations about sinking and floating. The findings suggested that manipulative experiences alone might not be enough for children to further their understandings about objects' behavior in water. This same study revealed that with the aid of scaffolding the teaching, children could better understand about sinking and floating. Kallery (2015) carried out action research to help preschoolers to adjust their initial explanations of objects' behavior in water (sinking or floating) by shifting their attention from the objects to the materials used to make the objects. This study also reported that pupils' knowledge of sinking and floating could be constructed through the adult and child working together on particular learning tasks under adult guidance or in collaboration with more capable peers. In the context where this study has taken place, a minimum collaboration between students; students and teacher emerged. As these students were from a disadvantaged background, they tend to carry their problems from home to the classroom and exhibits various destructive behaviors. Past studies depicted that students from this kind of background should be taught to manage their social and emotional competency. With managing both

**Table 1.** Description of participants' characteristics

Pupils	Names	Description of the characteristics of the pupils
Pupil 1-4	Ellen, Katherine, Hubert and Wilson	These are the smart pupils. They obtained good grades in science.
Pupils 5-7	May, Jackson and Sean	These are the average pupils. Jackson and Sean are more proactive than May. They are willing to participate in class activities, but they are talkative and less attentive in class.
Pupils 8 and 9	Queenie and Wendy	These are passive pupils. Their academic performance is below average. Most of the time, they just sat quietly and were reluctant to take part in any classroom activity. They are quiet and less attentive in the class.
Pupil 10	Jack	He as an extrovert pupil. He is good in sports but does not like classroom learning. His attention is always distracted during class. Most of the time he cannot follow the instructions in the class. He always disturbs others and does not hand in the homework given by his teachers. His academic performance indicates that he is weak in his studies.
Pupil 11	Zane	Zane is a pupil with mild autism. Most of the time, he cannot get along with other classmates well and is unable to control his emotions. He always cries and throws things when he is angry.
Pupil 12	Sunny	Sunny is a passive and quiet pupil. He is a Thalassemia patient. He is always passive and reluctant to participate in discussions. He is always seen to be less energetic, sleeps in the class, faces difficulty to concentrate and has poor stress tolerance.
Pupil 13-16	Darrel, Andy, Trudy and Nessa	These are the non-native speakers in the class. Language barriers make them unable to cope with studies in school. Their academic performance is very low and usually appeared less confident.

Note. All the given names are pseudonyms

competencies, behaviors are more controlled. As such in this study, *SEL* strategies were employed to teach the students the lessons on sinking and floating. This is because sinking and floating forms the basis for the Year 1 science curriculum and students face difficulty in understanding these concepts.

## Research Question

The study was guided by the main research question: How do students develop the basic ideas about sinking and floating when *SEL* strategies were used?

## METHODS

### Research Context

Since the parents invest a large amount of time on their jobs, they focused less on their children's academic performance. There were also pupils with single parents. These pupils with less encouraging support from the parents coupled with the high demand of the education system which requires them to learn seven academic subjects, most of the time appeared less motivated in school. Particularly, enormous challenges were encountered by teachers in delivering abstract science concepts to pupils who faced various constraints in the home environment as well as in schools (Kallery, 2015). *SEL* being an approach that effectively improves social and emotional competency (Fishbein et al., 2016) of the pupils is expected to encourage pupils learning of science.

### Sample

The sample for this study consisted of 16 seven-year-old Year 1 pupils. The academic achievements of the participants in this study ranged from excellent to very poor. The proportion of the weak academic achievers in the class was larger than the high achievers. Most of the Year 1 pupils in this study had two to three years of preschool education from a local kindergarten before enrolling into Year 1. In preschool, science is not taught as a formal subject. As such the prior knowledge of the pupils was mainly from their daily experiences. At the local kindergarten, the children were handled entirely by one untrained teacher. Two pupils in this class did not receive preschool education. Sunny did not receive a preschool education due to his health problem while Darrel due to poverty was unable to enroll in preschool. In **Table 1** the 16 pupils' names and a brief description of their characteristics are provided. The descriptions provided in **Table 1** shows that the 16 students possess a fewer similar and some distinctive characteristics. The non-native speakers, apparently due to language barrier unable to cope with the studies; the good ones seem to be able to follow the lessons well; the average students exhibit behavioral issues; some of them are passive learners and students with medical issues.



**Table 2.** Progression of the lessons

Lessons	Progression of the lessons
1	Pupils watched the YouTube video clip "Who Sank the Boat". While watching pupils responded to the question who sank the boat. The pupils were noticed listening and watching the video attentively.
	Pupils were asked to draw a picture to reflect their understanding of the video clip.
	Pupils were asked to guess behavior (sink and float) of a candy; test the behavior in water; and how the behavior changed when the candy is wrapped with air.
Pupils worked in group experimenting the behaviors (sinking or floating) of materials provided by the teacher	
2	Greeting and sharing the feelings of each other.
	Watched the video clip on making submarine-1.
	The teacher demonstrated on how to transform sinking objects to float.
Pupils worked in a group and investigated on how to use the available materials to float the sinking objects.	
3	Greeting and sharing the feelings of each other.
	Watched the video clip on making submarine-2.
	The teacher demonstrated on how to transform floating objects to sink.
Pupils worked in group investigated on how to use the available materials to sink the floating objects.	

## Research Design

In this qualitative descriptive case study Year 1 pupils' understanding about sinking and floating based on teaching using *SEL* strategies were explored. In total three lessons were performed in six weeks. In lesson 1 pupils were introduced to sinking and floating concepts. In lesson 2 using the knowledge obtained in lesson 1, they were expected to modify sinking objects to float and conversely in lesson 3 pupils were expected to apply the knowledge from lessons 1 and 2 to modify floating objects to sink. Worksheets were provided after lessons 1 and 3; interviews were conducted after the three lessons and observations were performed throughout all the three lessons. Data obtained from these three methods were triangulated to explain the pupils' understanding about sinking and floating.

## SEL Teaching Strategies

The *SEL* teaching strategies employed in all the three lessons adapted the suggestions proposed by Schonfeld et al. (2015). The lessons executed by Schonfeld covered four major areas: emotional awareness; self-control; problem-solving skills and developing peer relationships. The four major areas proposed by Schonfeld guided the three lessons implemented in this study.

In lesson 1, pupils were introduced to sinking and floating concepts. This lesson highlighted the importance of understanding emotions and to build a good relationship between friends to maintain a conducive environment for learning. In lessons 2 and 3 the focus was more on identifying the problems exist among them, setting goals to solve the problem and ultimately suggesting solutions to the problems. The progression of each lesson is provided in **Table 2**. The details of lessons 1, 2 and 3 are illustrated in next following section.

## Lessons

**Lesson 1.** In the introduction, a YouTube video clip "Who Sank the Boat" by Pamela Allen was shown to the pupils. The video clip is about a cow, a donkey, a sheep, a pig and a little mouse who decided to go for a row. Listening to the story the pupils need to predict who will sink the boat? At first, the cow jumped on to a boat. As the boat was about to sink, the donkey jumped in to balance the weight. The pig as fat as butter then stepped on the side and caused a great flutter; the sheep who loves to knit sat at the side to level the boat so that she could knit, and finally the little mouse got onto the boat. While watching each slide, the teacher prompted the pupils with the question 'Who sank the boat?' Pupils were reminded that they were only given a single chance to guess the answer. While the story was in progress, the pupils were noticed gazing onto the screen and listening attentively. Each time when the teacher asked 'who sank the boat' they tried to discuss with their friends and suggest an answer.

After watching the video, pupils were asked to draw their understanding about sinking and floating on a piece of paper. The teacher repetitively reminded the pupils that "This is not a drawing test, you don't have to draw well" so that the pupils could focus more on presenting their understanding rather than drawing. At the same time, the teacher encouraged the pupils to add explanations to the picture. A class discussion was held after the drawing activity to discuss the drawings. Following this, pupils weighed a candy by using their hand and decided whether

Worksheet 1

1. Tick the correct answer on the box given according to the object's behaviour in the water.

	Object	Float	sink
a.	Wooden pencil	<input checked="" type="checkbox"/>	<input type="checkbox"/>
b.	apple	<input checked="" type="checkbox"/>	<input type="checkbox"/>
c.	eraser	<input type="checkbox"/>	<input checked="" type="checkbox"/>
d.	Plastic toy	<input checked="" type="checkbox"/>	<input type="checkbox"/>
e.	seashell	<input type="checkbox"/>	<input checked="" type="checkbox"/>
f.	candle	<input checked="" type="checkbox"/>	<input type="checkbox"/>

2. Which object float? Which object sink? Fill in the blank with the alphabet which represents the object.

a.  P

b.  Q

c.  R

d.  S

e.  T

f.  U

g.  V

h.  W

i.  X

Float	P, R, T, V
sink	Q, S, U, W, X

Figure 1. Questions included in Worksheet 1

the candy will float or sink. The candy was put into a transparent container containing water to test its behavior in the water. These steps were repeated by using a milky candy bar with air in the wrapper. This activity encouraged pupils to make predictions and do experiments to prove their prediction.

Then, the pupils carried out experiments to test the behaviors of the objects provided by the teacher in the water. During the activity, the teacher reminded the pupils to follow certain rules in the investigation. Pupils were firstly asked to touch, weigh and observe the objects closely, but not to put the objects into the water until the teacher instructed them to do so. The pupils wrote down their predictions on a piece of paper after observing the objects. After that, the pupils carried out experiments to prove their predictions. The lesson ended with a group discussion lead by the teacher to guide them to generalize their findings. Finally, a worksheet was distributed to assess their understanding of the lesson. Figure 1 illustrates the content of worksheet 1.

**Lessons 2 and 3.** In lessons 2 and 3, pupils modified sinking objects to float and floating objects to sink followed with presenting their work in front of the class. In both lessons, pupils were given a problem-solving task. They had to solve the problem by following the steps and evaluate their solution and share their feelings after the lesson. The lessons were conducted based on the problem-solving guidelines proposed in the modules (Greenberg & Kusche, 1998). Both lessons started with the teacher helping calm down the pupils. For this purpose, she asked the pupils to greet each other individually and encouraged them to talk to each other to share their feelings. Some came forward and said that they were not ready to study; unhappy; the day seems to be boring; they are confused about the previous lesson; few said they are not interested with the lesson. If possible, they requested the teacher not to perform the teaching. Upon considering all the pupils' feelings, the teacher diverted the pupils' attention from the stressful to lower stress condition by allowing the pupils to watch a video clip on how to make a submarine available at [www.youtube.com/watch?v=ql5NykrDHN0](http://www.youtube.com/watch?v=ql5NykrDHN0). After watching the video, the pupils appeared more cheerful than earlier. After that, the teacher demonstrated how to float a clip. Firstly, she placed a clip into a transparent plastic container with water in it to show that the clip will sink in water. The teacher asked them how they could float the clip. The teacher later tied a cork to the clip using a rubber band and again placed it into the water. It was noticed the clip tied to a cork floats. Following the demonstration, pupils were asked to work in group to float a marble in lesson 2 and to sink a table tennis ball in lesson 3 using the provided materials. In lesson 2, pupils in groups were asked to choose three objects out of ten objects (play dough, clips, candles, rubber bands, wooden blocks of different sizes, sponges, clothes, needles, nails and table tennis balls). Similarly, for lesson 3 they were asked to pick three objects from play dough, clips, sand, rubber band, straws, sponges, marble balls, needles, nails and plastic bags. After many attempts of testing finally, the pupils reached a decision and conclusion. For instance, using the idea from the demonstration, one group tried to float the marble by tying it to a wooden block. They tried to stick the marble to the play dough but failed. Finally, this group managed to float the marble by tying the marble to a bigger wooden block. Another group tried tying the marble to a table tennis ball but again failed to float the marble. At last one student from this group asked permission to cut open the table tennis ball and placed the marble into the tennis ball. With the experience of handling problem-solving tasks in lesson 2, in lesson 3 pupils

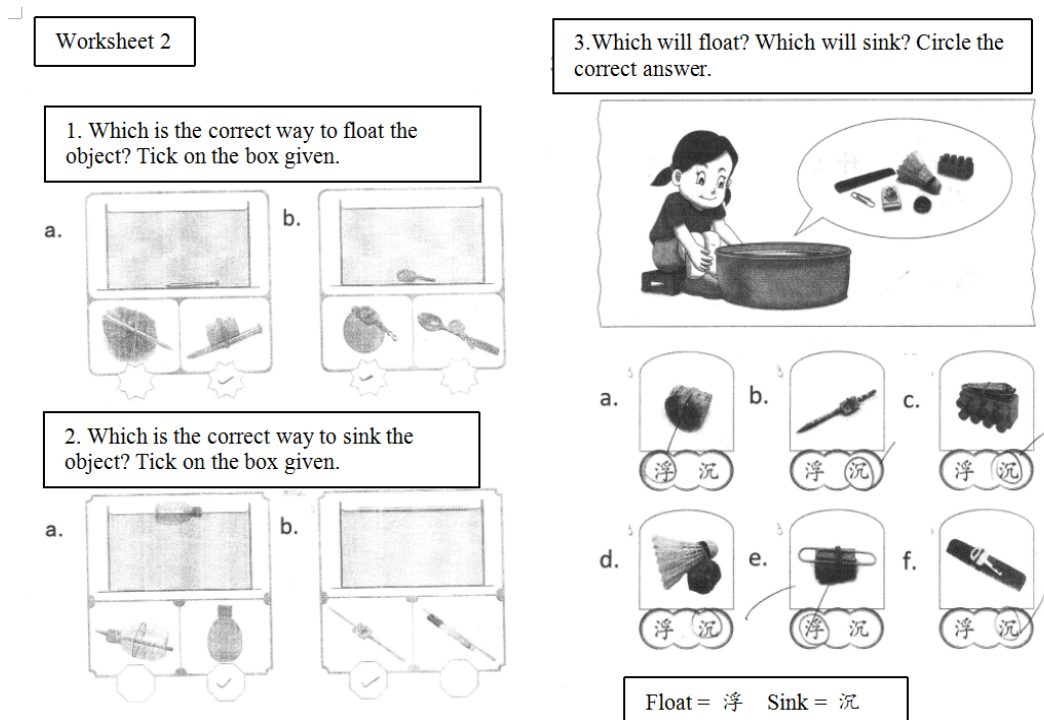


Figure 2. Questions included in Worksheet 2

managed to reach a decision faster when they were asked to sink a table tennis ball. A group of pupils tried to wrap the table tennis ball with play dough but failed to sink the table tennis ball. Finally, the pupils decided to cut open the table tennis ball and filled the inner space of the table tennis ball with play dough. Another group of pupils used a nail to make a hole in the table tennis ball and let the water flow into the table tennis ball to sink it. The other group also made a hole using a nail and filled the table tennis ball with sand and sank it. Worksheet 2 as shown in Figure 2 was used to gauge the understanding obtained from Lesson 2 and 3.

### Data Sources

**Floating and sinking worksheets.** Pupils were asked to respond to two worksheets. Worksheet 1 was given after lesson 1 and worksheet 2 after lesson 3. The worksheets were adapted from the activity book by Lao and Chiew (2010). In worksheet 1, pupils needed to determine whether the six objects listed would float or sink. In worksheet 2 three questions were asked: In question 1 a key was placed into a beaker filled with water. Pupils were provided with two options to make the nail float: tie the nail to a bundle of thread or tie an empty tin to the nail. In another beaker, a key was placed into water. Pupils were provided with two options on how to make the key float: tie the spoon to a balloon filled with air or tie the key to a spoon. In question 2 pupils were provided with two situations. In situation 1, pupils were given a floating empty plastic bottle. They had to decide on how to make the bottle to sink either by tying the bottle to a pencil or filling the bottle with water. In the situation, 2 pupils were provided a pencil floating on the water. In making the pencil of sinking they had to choose between tying the pencil to an eraser or tying the pencil to a marker pencil. In question 3 six situations were given: a coin tied to a cork, a pencil tied to an eraser, a nail clipper tied to a plastic toy, a shuttlecock tied to a stone, a paper clip tied to a cork, a and key tied to a comb. Pupils were asked to decide whether these objects would float or sink when placed in water.

**Semi-structured interviews.** Semi-structured interviews involving all the 16 participants were conducted after each lesson. The purpose of the interviews was to identify pupils’ understanding about sinking and floating and to determine how they applied the knowledge to modify sinking objects to float and vice versa. Following are the interview questions:

- (1) Why did some objects float and others sink?
- (2) How would you make a nail or a key to float?
- (3) How would you make an empty bottle or straw to sink?

During the interviews, questions were added to probe the pupils’ understanding further. The probing questions were posed when incorrect, partially correct or no answers were given during the interviews.

**Classroom observations.** Observations were conducted throughout all the three lessons. The first author played the role of participant observer and conducted the observations. All the lessons were video-recorded and transcribed to obtain more information. Additionally, field notes were recorded. The first author conducted the observations based on the following: number of pupils who asked questions; the number of questions asked by the pupils and type of questions asked; engagement in learning; participation in group activities; and non-verbal facial expressions.

## RESULTS

### Worksheet Analysis

**Analysis of worksheet 1 after lesson 1.** After lesson 1, 12 pupils (Wilson, Ellen, Katherine, Hubert, May, Jackson, Sean, Wendy, Zane, Andy, Trudy & Nessa) were able to correctly identify that a wooden pencil, an apple, a plastic toy, and candle will float on water. An eraser and seashell would sink into the water. On the contrary, three pupils (Queenie, Sunny and Darrel) had indicated that a candle would sink in water. As noticed in the class discussion, these three pupils presumed that the candle was made of plastic. Queenie also had the understanding that an apple would sink in water. These misconceptions might be due to the experiences encountered in their daily lives.

**Analysis of worksheet 2 after lessons 2 and 3.** Analysis of situation 1 in question 1 of worksheet 2 showed that 13 pupils managed to indicate that the nail that would sink in water but would float when tied to a thread. Only three pupils (Jack, Sunny and Darrel) provided incorrect answers. This showed that Jack, Sunny and Darrel still could not grasp the knowledge learned in lesson 1 firmly. For situation 2 in question 1, all the 16 pupils provided correct answers by saying that a floating key, when tied to a balloon filled with air, would sink. Similarly, for question 2 all the 16 pupils managed to acquire the knowledge that a floating empty plastic bottle would sink when filled with water compared to tying it to a pencil. They also said that a floating pencil would sink when tied to a marker pen rather than to an eraser. For question 3, the majority of the pupils (12) made a correct decision on the characteristic of the objects listed, whether they would float or sink when placed on water. However, four pupils (Darrel, Nessa, Jack and Sunny) made a few incorrect decisions. Darrel and Nessa assumed that the cork which was tied together with a coin would float because the coin which is made of metal is heavy enough to sink the cork. Jack and Sunny assumed that a pencil which was tied together with an eraser would float. According to Sunny, this is due to the size of the pencil which is bigger than the eraser. These kinds of responses indicated that pupils were still having some misconceptions because in deciding sinking or floating pupils only paid attention to a single dimension of the objects (either weight or size) and failed to consider both dimensions as weight and size collectively determine the sinking or floating property of the objects.

### Interview Analysis

**Analysis of interview responses after lesson 1.** When the question "Why some objects float and others sink?" was asked 12 pupils provided correct responses. Following are the responses provided by the 12 pupils.

- Wilson : Because the objects are made of wood, plastic or contain air.  
Ellen : Because the objects are made of wood or plastic that makes them float.  
Katherine : I think should be the material .... wooden things will float, plastic will also float.  
Hubert : The objects are made of wood, plastic, or contain gas.  
Jackson : Emm ..... maybe because it is wood, so it floats, objects made of the iron sink.  
Sean : Objects that made of wood, plastic ..... or contain air, float.  
Wendy : Wooden objects float, metal objects sink.  
Zane : Because of a wooden pencil floats ..... It is made of wood ..... Rubber sinks.  
Darrel : Wooden objects float. Eraser and iron sink.  
Andy : It is made of wood, so it floats ..... metal objects sink ..... rubber sinks, too.  
Trudy : Empty objects float ..... yes, it contains air.  
Nessa : Wooden objects float.

The responses of these 12 pupils indicated that these pupils acquired the knowledge about sinking and floating of an object because of the materials of the objects. The remaining four pupils (May, Queenie, Jack, and Sunny) exhibited partial understanding about the basic ideas of sinking and floating. As shown in the excerpts below initially these pupils mentioned that the weight of the object determined the object's behavior in the water. After

the interviewer prompted (using questions in italics in the excerpts below), these pupils corrected themselves and were able to provide correct responses as shown below:

- May : Light objects (*Are you sure? ..... Do you mean all light objects can float?*) .. Oh, No .. Em .. (*What kind of objects can float?*) the objects that are made of wood.
- Queenie : Emm ..... (*think back the activity done in the class, Why could some objects float?*) because it is light ..... (*So you mean that light objects can float?*) No .. Em ..... because it is made of wood.
- Jack : Because it is light ..... (*So you mean that light objects can float?*) No, not necessarily light objects float. It also depends on the material. Metal objects sink.
- Sunny : Light objects float .. (*Are you sure? .. Do you mean all light objects can float?*) No, because it is made of wood, so it floats.

**Analysis of interview responses for lessons 2 and 3.** In order to obtain further insights on how pupils applied their understanding to modify floating objects to sink or vice versa, interviews were conducted. When the question "How would you make a key or a nail float?" was asked, the following are the responses provided by the 16 pupils. The responses obtained were classified into three categories as below:

***Pupils who showed firm and excellent understanding***

Katherine, Ellen, Hubert, May, Jackson: Tie the object to another floating object.

***Pupils who showed good basic understanding***

- Wilson : Put the object on a wooden plank.
- Sean : Tie the object to a table tennis ball.
- Wendy : Put in a bowl ..... Can it be?
- Zane : Put in a bottle ..... empty bottle floats.
- Queenie : Stick it on a ball.
- Darrel : Tie together with a table tennis ball.
- Andy : Tie together with a table tennis ball.
- Trudy : Stick on a wooden block.
- Nessa : Tie to a balloon.

***Pupils who showed partial understanding***

- Jack : Em put ... tie to a light object ..... em ..... no ..... stick it to a table tennis ball.
- Sunny : Put it on a ship ..... because the ship floats ..... yes ..... tie to floating objects.

From the interview outcomes, it could be postulated that the pupils understood that floating objects could be used to enable sinking objects to float. Katherine, Ellen, Hubert, May and Jackson confidently provided exact correct responses. Other pupils asserted that a nail or key could float if it were tied to a table tennis ball, a balloon or a wooden plank. Wendy appeared less confident with her answer even though she was giving the correct answer. Sunny and Jack showed partial understanding about the lessons. Jack was found to hold some misconceptions about sinking and floating. He assumed that light objects could be used to float a sinking object. When Sunny was prompted by the interviewee to identify ways to make the key or the nail to float guided with the questions: if the key is tied to a rock can the key float? Or if it were tied to a balloon or would the nail float if tied to a tennis ball or cork? He was able to tell that floating objects could be used to make the sinking objects to float after he was prompted by the interviewer.

When the question "How to make an empty bottle or straw to sink?" was asked following are the responses provided by the 16 pupils. The responses were classified into two categories as presented below:

***Pupils with firm and excellent understanding***

- Ellen : Use a sinking object to help it sink.
- Hubert, May, Jackson : Tie it with a sinking object.
- Wilson : Put some water or clay in the bottle, make sure there is no air inside, so it cannot float.

***Pupils with good basic understanding***

- Katherine : Tie the straw with rubber or iron to make it sink.
- Sean : Tie it with a magnet bar.
- Queenie : Em ..... stick it with an iron rod.
- Wendy : Fill the bottle with sand?
- Jack : Make a hole in the bottle.

- Zane, Sunny : Put water in it.  
Darrel : Tie it to iron.  
Andy : Tie it to an eraser.  
Trudy, Nessa : Tie it to a rock.

The interview responses indicated that the pupils had a good basic understanding about sinking and floating. The pupils knew sinking objects such as an iron rod, clay and magnet could be used to modify floating objects to sink. It was also noticed that four pupils claimed that tying or sticking the straw or bottle with a sinking object could make the straw or the bottle sink. The interview responses also showed that Wilson could justify his answer very well. This indicated that the pupils were able to apply the knowledge about sinking and floating to modify the floating object to sink excellently.

### Classroom Observations (Lessons 1, 2 and 3)

In lesson 1, it was noticed that none of the pupils asked any questions. In lessons 2 and 3 many questions were asked. In lesson 2 it was noticed that six pupils posed questions to the teacher. This indicated that the interactions between the teacher and the pupils had improved since the first lesson. Questions posed in lesson 2 could be described as questions to clarify the problem-solving tasks and questions of higher order thinking level.

#### *Questions to clarify the problem-solving task*

- Ellen : Teacher, can I change the objects chosen just now?  
Katherine : How to tie the marble and the wooden block?  
Hubert : Teacher, how can I tie the marble and the wooden block?  
May : Teacher, shall I change the objects?  
Jackson : What do we need to do now? Can I change the ball with other objects?; Teacher, shall we use the all three objects to modify the marble to make it float?

#### *Questions with higher order thinking level*

- Wilson : Can I cut the table tennis ball?

Most of the questions asked by the pupils were regarding problem-solving tasks. It was noticed that Jackson asked the most number of questions during the lesson. This might be due to the lack of understanding in solving the problem-solving task. Meanwhile, it was noticed that Wilson could think critically as the question asked reflected that Wilson had a firm basic idea of sinking and floating and Wilson was able to apply the knowledge of sinking and floating to find a solution to float the marble. From the class observations, it was also noticed that the pupils who asked questions to the teacher were the more capable pupils in the group.

**Table 3** shows the number of responses given by the pupils to the questions raised by the teacher during the lessons 1, 2 and 3. As presented in **Table 2**, on average of 6.31 responses were obtained in lesson 1. In lesson 2 the average increased to 9 and 11.44 in lesson 3. In lesson 1, it was also noticed that Queenie and Sunny were passive and reluctant to participate in the lesson 1 as they answered only one question. Jack, Jane and Darrel were also very passive in the class. They only answered two questions whereas Nessa, Wendy and Trudy answered four, five, and seven questions raised by the teacher, respectively. Sean, May and Wilson showed moderate engagement in the learning. These three pupils answered eight questions raised by the teacher throughout the lesson. It was noticed that Jackson was highly engaged in the learning process and answered 15 questions asked by the teacher even though he was uncertain about the answers. Besides these Ellen, Katherine and Hubert were also highly engaged in the lesson and answered most of the questions asked by the teacher which are 11, 13 and 14 questions, respectively. These pupils appeared very confident in expressing the answers. In terms of participation in the group, it was found that Queenie and Zane were less engaged in the group activity. It was also observed that Queenie and Zane did not contribute to the group discussion. Queenie sat quietly while Zane did not cooperate with other group members but was doing his work. Therefore, other group members had difficulties to work together with Zane. On the other hand, Jack was noticed to disturb other pupils when the group discussion was in progress. From the observations, Jack was found to have difficulties following the teacher's instruction to complete the task. He walked around in the class when his group members did not entertain him. It was also noticed that Sunny's attention was easily distracted. This student did not listen attentively to the teacher or his friends during the first lesson. This might be due to his health problem as he was diagnosed as a Thalassemia patient. Generally, throughout lesson 1, from their facial expressions, pupils looked cheerful for the whole lesson except Sunny whose eyes looked hollow and did not show any facial expressions.



**Table 3.** Number of Responses Given by the Pupils during Lesson 1, 2 and 3

Student	Lesson 1	Lesson 2	Lesson 3
Sunny	1	3	7
Darrel	1	3	8
Jack	1	5	7
Trudy	5	7	8
Nessa	4	7	8
Wendy	5	8	12
Andy	3	8	12
Queenie	1	8	9
Ellen	11	10	13
Katherine	13	10	15
Sean	8	10	12
May	8	10	13
Zane	1	12	14
Hubert	14	14	15
Jackson	15	15	15
Wilson	8	15	15
Average	6.31	9	11.44

In lesson 2, Jackson and Wilson answered the most numbers of questions (15). The number of pupils who answered 15 questions in lesson 3 increased to three pupils (Jackson, Wilson and Hubert). It was noticed that Sunny and Darrel answered the least questions: three questions in lesson 2, followed by Jack who managed to answer five questions during Lesson 2. In lesson 3 Sunny and Jack answered seven questions each and Darrel answered eight questions. Meanwhile, both Trudy and Nessa answered seven questions in lesson 2 and eight questions each in lesson 3 whereas Wendy, Andy and Queenie answered eight questions each during lesson 2. On the other hand, Wendy and Andy answered 12 questions each in the lesson 3. Queenie showed notable increment in the responses given to the teacher during lesson 2; number of responses given by Queenie increased from one question in Lesson 1 to eight questions in lesson 2 and nine questions in lesson 3. It was also noticed that Zane's responses to the teacher increased from two questions to 12 questions in lesson 2 and 14 questions in lesson 3. Similarly, Wilson's responses to the teacher also showed an increment from lesson 1 to lesson 3. He answered eight questions in Lesson 1 and 15 questions each in the lessons 2 and 3. It was found that Ellen, Katherine, Sean and May answered ten questions each during lesson 2 while Hubert and Jackson answered 14 questions during lesson 2. It was reported that Sean and Wendy answered 12 questions each whereas Ellen and May answered 13 questions each and Zane answered 14 questions in lesson 3.

The group activities designed in the lessons 2 and 3 were problem-solving tasks. The pupils collaboratively discussed in groups to find out the solutions to float the marble in lesson 2 and sink a table tennis ball in lesson 3. At first, the pupils looked confused. It was observed that the more capable members of the group conferred with the teacher and other group members before solving the problem. The teacher let the pupils solve the problems tentatively before giving any guidance. Queenie and Sunny showed increased participation in group discussions. These two pupils started to involve themselves in the group discussions beginning from the second lesson. It was also noticed that Jack did not walk around the class (as he did in lesson 1) but he did not contribute to the discussion and group activities. This indicated that the *SEL* strategy was able to reduce occurrences of disruptive behavior in the class.

During the lessons, most of the pupils looked serious when the pupils were conducting the problem-solving task except Jack. At the end of the lesson, the pupils looked cheerful as the pupils gained a strong sense of accomplishment in completing the task successfully. From the pupils' facial expressions, the pupils looked brighter when they were on the problem-solving tasks. The pupils even asked for more similar activities in their future science classes. This might be due to the success in solving the tasks enabled the pupils to gain a strong sense of fulfillment which motivated them to learn more.

## DISCUSSION AND CONCLUSION

In response to the main research question of the study (How do students develop the basic ideas about sinking and floating?), the data obtained from the worksheet indicated that 12 out of 16 pupils developed the basic ideas about sinking and floating. They were able to change their initial misconceptions that light objects float and heavy objects sink to correct conceptions that materials of the objects determined the behaviors of the object in the water. The interview responses and classroom observations showed that pupils were well engaged and participated in the learning. From these findings, it could be postulated that enhanced understanding about sinking and floating

and the encouraging learning environment was derived from the *SEL* lessons. From the explanations given in the interviews, the findings of this study revealed that the pupils were able to elaborate on the sinking and floating properties of an object by relating to the material used to make the objects. This is similar to the findings reported in previous studies (Kallery, 2015; McDonald, 2012). McDonald (2012) and Kallery (2015) asserted that 'material kind' would be more appropriate to be introduced to the primary pupils than the term 'density.'

The findings of this study indicated that pupils had actively participated in the learning. Active participation was reflected when the pupils eagerly answered the questions in the class and also enjoyed the group activities. This has subsequently created a positive learning atmosphere which had facilitated pupils' learning and promoted their understanding about sinking and floating. Hence, it could be postulated that the improved knowledge observed among the pupils was probably due to the social interaction that occurred between students and the teacher and between students. The findings obtained from this study are parallel with the claim that during the *PATHS* (a *SEL* program) lessons 80% to 96% is the instruction time where pupils cooperatively engaged in the learning (Bardon, Dona & Symons, 2008). As a result of this collaborative learning atmosphere, *PATHS* lessons developed social and emotional learning effectively and subsequently had resulted in better learning (Bardon et al., 2008).

The *PATHS* lessons have enabled the pupils to interact effectively and this has resulted in a healthy classroom atmosphere (Martinson & Damberg, 2016). A healthy classroom environment was noticed in the *SEL* lessons because the approaches employed in the *SEL* lessons provided opportunities for pupils to learn from peers, discuss with peers and carry out tasks together with their peers to explore science and have a whole class discussion (Martinson & Damberg, 2016). Similarly, storytelling and hands-on activities in this study helped the pupils to identify their own emotions and be more empathetic and cooperative with others in the group activities or collaborative learning. It facilitated the pupils learning as the pupils worked cooperatively and collaboratively.

The positive outcome derived from the *SEL* strategies used in this study could be explained using the *ABCD* model (Kusche & Greenberg, 1994). The lessons on sinking and floating were based on *SEL* principles of establishing a positive relationship among the learning communities and setting an encouraging learning environment with reduced challenging behaviors that enabled the pupils to understand their feelings and feelings of others better. By understanding the feelings of others, the pupils learned to respect their friends' opinions, and interacted with them positively. This leads to the improvement in the pupils' social and emotional competence. With better social and emotional competence, the pupils managed their own emotions better. With more stable emotions, the pupils communicated more effectively in the group and class discussions. This subsequently reduced the disruptive behavior in the class and helped to engage them better in the learning process. When the pupils were socially and emotionally competent, they handled the relationships with their friends and the teacher better. These subsequently helped them maintain good communication. The problem-solving tasks in lessons 2 and 3 created more opportunities for the pupils to consider all possible factors when making decisions, reaching to an appropriate conclusion by taking into consideration different viewpoints, and taking responsibility for the decisions. This subsequently helped the pupils to improve their critical thinking skills which enabled them to apply the knowledge learned in modifying floating objects to sink and vice versa.

The studies that were conducted by Kallery (2015) also asserted that collaborative learning was effective in developing the concepts of sinking and floating among young children. Also, Kallery (2015) stated that whole class discussions and group discussions would help to develop children's scientific reasoning skills. Hence, *SEL* strategies in this study which involved many social learning activities such as collaborative learning, problem-solving tasks, and group and class discussions assisted the pupils to reason their decisions effectively and to critically apply their knowledge of sinking and floating to modify sinking objects to float and vice versa.

In the context of this study, the participating pupils were from a rural area with parents of low socioeconomic background. For pupils from disadvantaged groups, schooling is a challenge. The situation is exacerbated with pupils having single parents, autism and being non-native speakers. Ordinary teaching strategies if employed to teach these kinds of pupils perhaps will further add to pupils' stress levels with tendencies for them to show disinterest in learning. Strategies that permit the teacher and the pupils to understand their emotions and challenges and maintain low-stress levels throughout the lessons such as in *SEL*, helped to create improved learning contexts. However, in this study, the lessons were focused only on learning about sinking and floating. It is suggested that investigating how *SEL* strategies could be implemented in learning other science concepts and perhaps involving larger groups of pupils from different rural areas in the future.

## REFERENCES

- Bardon, L. A., Dona, D. P., & Symons, F. J. (2008). Extending class wide social skills interventions to at-risk minority pupils: A preliminary application of randomization tests combined with single-subject design methodology. *Behavioral Disorders*, 33(3), 141-152. <https://doi.org/10.1177/019874290803300302>
- Berger, C., Alcalay, L., Torretti, A., & Milicic, N. (2011). Socio-emotional well-being and academic achievement: Evidence from a multilevel approach. *Psicologia: Reflexaoe Critica*, 24(2), 344-351. <https://doi.org/10.1590/S0102-79722011000200016>
- Biddulph, F., & Osborne, R. (1984). Pupils' ideas about floating and sinking. Pupils' ideas about floating and sinking. *Research in Science Education*, 14(1), 114-124. <https://doi.org/10.1007/BF02356797>
- Brock, L. L., Nishida, T. K., Chiong, C., Grimm, K. J., & Rimm-Kaufman, S. E. (2008). Children's perceptions of the classroom environment and social and academic performance: A longitudinal analysis of the contribution of the Responsive Classroom approach. *Journal of School Psychology*, 46(2), 129-149. <https://doi.org/10.1016/j.jsp.2007.02.004>
- Butts, D. P., Hofman, H. M., & Anderson, M. (1993). Is hands-on experience enough? A study of young children's views of sinking and floating objects. *Journal of Elementary Science Education*, 5(1), 50-64. <https://doi.org/10.1007/BF03170644>
- Durlak, J. A., Weissberg, R. P., Dymnicki, A. B., Taylor, R. D., & Schellinger, K. B. (2011). The impact of enhancing pupils' social and emotional learning: A meta-analysis of school-based universal interventions. *Child Development*, 82(1), 405-432. <https://doi.org/10.1111/j.1467-8624.2010.01564.x>
- Fishbein, D. H., Domitrovich, C., Williams, J., Gitukui, S., Guthrie, C., Shapiro, D., & Greenberg, M. (2016). Short-term intervention effects of the PATHS Curriculum in young low-income children: Capitalizing on plasticity. *The Journal of Primary Prevention*, 37(6), 493-511. <https://doi.org/10.1007/s10935-016-0452-5>
- Fleer, M. (2013). Affective imagination in science education: Determining the emotional nature of scientific and technological learning of young children. *Research in Science Education*, 43(5), 2085-2106. <https://doi.org/10.1007/s11165-012-9344-8>
- Fox, L., Dunlap, G., Hemmeter, M. L., Joseph, G. E., & Strain, P. S. (2003). The teaching Pyramid: A model for supporting social competence and preventing challenging behavior in young children. *Young Children*, 58(4), 48-52.
- Goleman, D. P. (1995). *Emotional intelligence: Why it can matter more than IQ for character, health and lifelong achievement*. New York: Bantam
- Greenberg, M. T., & Kusche, C. A. (1998). Preventive interventions for school-age deaf children: The PATHS curriculum. *Journal of Deaf Studies and Deaf Education*, 3, 49-63. Retrieved from <http://www.jstor.org/stable/23805415>
- Hardy, I., Jonen, A., Möller, K., & Stern, E. (2006). Effects of instructional support within constructivist learning environments for elementary school students' understanding of "floating and sinking". *Journal of Educational Psychology*, 98(2), 307-326. <https://doi.org/10.1037/0022-0663.98.2.307>
- Havu-Nuutinen, S. (2005). Examining young children's conceptual change process in floating and sinking from a social constructivist perspective. *International Journal of Science Education*, 27(3), 259-279. <https://doi.org/10.1080/0950069042000243736>
- Hemmeter, M. L., Ostrosky, M., & Fox, L. (2006). Social and emotional foundations for early learning: A conceptual model for intervention. *School Psychology Review*, 35(4), 583-601.
- Honess, A., & Hunter, D. (2014). Teacher perspectives on the implementation of the PATHS curriculum. *Educational Psychology in Practice*, 30(1), 51-62. <https://doi.org/10.1080/02667363.2013.869490>
- Hsin, C. T., & Wu, H. K. (2011). Using scaffolding strategies to promote young children's scientific understandings of floating and sinking. *Journal of Science Education and Technology*, 20(5), 656-666. <https://doi.org/10.1007/s10956-011-9310-7>
- Impedovo, M. A., Delseerieys-Pedregosa, A., Jégou, C., & Ravanis, K. (2017). Shadow formation at preschool from a socio-materiality perspective. *Research in Science Education*, 47(3), 579-601. <https://doi.org/10.1007/s11165-016-9518-x>
- Kallery, M. (2015). Science in early year's education: introducing floating and sinking as a property of matter. *International Journal of Early Years Education*, 23(1), 31-53. <https://doi.org/10.1080/09669760.2014.999646>
- Kam, C. M., Greenberg, M. T., & Kusché, C. A. (2004). Sustained effects of the PATHS curriculum on the social and psychological adjustment of children in special education. *Journal of Emotional and Behavioral Disorders*, 12(2), 66-78. <https://doi.org/10.1177/10634266040120020101>

- Kelly, B., Longbottom, J., Potts, F., & Williamson, J. (2004). Applying emotional intelligence: Exploring the promoting alternative thinking strategies curriculum. *Educational Psychology in Practice*, 20(3), 221-240. <https://doi.org/10.1080/0266736042000251808>
- Koslin, B. L., Koslin, S., Zeno, S., & Ivens, S. (1989). *The Degrees of Reading Power Test: Primary and standard forms*. Brewster, NY: Touchstone Applied Science Associates Degree of Reading Power Services.
- Krajcik, J., & Delen, I. (2017). How to support learners in developing usable and lasting knowledge of STEM. *International Journal of Education in Mathematics, Science and Technology*, 5(1), 21-28. <https://doi.org/10.18404/ijemst.16863>
- Kusché, C. A., & Greenberg, M. T. (1994). *The PATHS curriculum*. South Deerfield, MA: Channing-Beta Co.
- Lao, P. T., & Chiew, L. C. (2010). *Dunia, Sains dan Teknologi Tahun 1*. Kuala Lumpur; Malaya Press Sdn. Bhd.
- Lehrer, R., Schauble, L., Strom, D., & Pligge, M. (2001). Similarity of form and substance: Modeling material kind. *Cognition and Instruction: Twenty-five Years of Progress*, 39-74.
- Martinson, B., & Damberg, I. (2016). Qualitative analysis of teachers' written self-reflections after implementation of a social-emotional learning program in Latvia. *International Journal of School & Educational Psychology*, 1-11. <https://doi.org/10.1080/21683603.2016.1225236>
- McCormick, M. P., Cappella, E., O'Connor, E. E., & McClowry, S. G. (2015). Context matters for social-emotional learning: Examining variation in program impact by dimensions of school climate. *American Journal of Community Psychology*, 56(1-2), 101-119. <https://doi.org/10.1080/00368121.2012.671197>
- McDonald, J. R. (2012). Does It Sink or Float? *Science Activities: Classroom Projects and Curriculum Ideas*, 49(3), 77-81.
- Payton, J., Weissberg, R. P., Durlak, J. A., Dymnicki, A. B., Taylor, R. D., Schellinger, K. B., & Pachan, M. (2008). The positive impact of social and emotional learning for kindergarten to eighth-grade pupils: Findings from three scientific reviews. Technical Report. Retrieved on June 29, 2017 from <http://files.eric.ed.gov/fulltext/ED505370.pdf>
- Qi, C. H., & Kaiser, A. P. (2003). Behavior problems of preschool children from low-income families: Review of the literature. *Early Childhood Special Education*, 23(4), 188-216.
- Rimm-Kaufman, S., & McTigue, E. (2011). The 'Responsive Classroom' approach and its implications for improving reading and writing. *Reading and Writing Quarterly*, 27(1-2), 5-24.
- Schonfeld, D. J., Adams, R. E., Fredstrom, B. K., Weissberg, R. P., Gilman, R., Voyce, C., Tomlin, R., & Speese-Linehan, D. (2015). Cluster-randomized trial demonstrating impact on academic achievement of elementary social-emotional learning. *School Psychology Quarterly*, 30(3), 406-420.
- Tippett, C. D., & Milford, T. M. (2017). Findings from a Pre-Kindergarten classroom: Making the case for STEM in early childhood education. *International Journal of Science and Mathematics Education*, 1(15), 67-86.
- Tomas, L., & Ritchie, S. M. (2012). Positive emotional responses to hybridised writing about a socio-scientific issue. *Research in Science Education*, 42(1), 25-49. <https://doi.org/10.1007/s11165-011-9255-0>
- Vygotsky, L. S. (1978). *Mind and society: The development of higher mental processes*. Cambridge, MA: Harvard University Press.
- Zins, J. E., & Elias, M. J. (2007). Social and emotional learning: Promoting the development of all pupils. *Journal of Educational and Psychological Consultation*, 17(2-3), 233-255.

<http://www.ejmste.com>

# A New Mental Experience Quantification and Emotion Prediction Model for E-Learning Users

Hui Wang <sup>1\*</sup>, Ting-Cheng Chang <sup>1</sup>

<sup>1</sup> Ningde Normal University, Ningde, CHINA

Received 27 October 2017 • Revised 22 February 2018 • Accepted 12 March 2018

## ABSTRACT

At present, there exists a lack of an in-depth study on the quality of service evaluation of computer systems from the perspective of user psychological experience. This paper proposes an overall model for prediction of user psychological experience which is based on the environmental analysis of E-learning, the quantitative evaluation of user psychological experience and emotion. First, this study analyzes the impact of usability, usefulness, emotion and other factors on the psychological experience of E-learning users. Next, we use the resource coverage rate, recommendation hit rate and other indicators to measure usability and usefulness that are to construct the feature weight matrix and then use the AHP to quantify the overall user psychological experience evaluation model. The partial least squares regression method is adopted to take the individual characteristics of the learners as independent variables, and the characteristics of negative emotion regulation strategies as the variables. The proposed model can effectively find the E-learning system experience in the shortcomings of user psychology through a practical application. The results of this study can be used to build a more suitable quantitative evaluation method of user psychological examination for further study the characteristics of emotions affecting the user's psychological experience.

**Keywords:** quantitative evaluation, emotion prediction, user psychological experience, partial least squares regression

## INTRODUCTION

The speed and extent of service information development depends on the availability of Internet, computer technological and financial resources at this time, but in its essence development is a process that is determined by the response of user to their external environment. User experience is subjective, dynamic from time variations, environmental limited and different among individuals, which all demonstrate that there will never be identical user experiences (Calvo & D'Mello, 2010; Moridis & Economides, 2008). However, it is still possible to create similar user experience with certain designs when it comes to clear target customer groups, which requires in depth research and precise control to take all the circumstances of customers using the product into consideration.

Experience economy is a kind of subjective psychological feeling formed by users when they receive service. Researchers in computer science, psychology, sociology and other fields have studied user experience from their respective perspectives and applications. In the process of service acceptance, the user, computer system and objective environment will affect the quality of user experience (Broekens & Brinkman, 2013; Ortigosa, Martín, & Carro, 2014). The current research on the user experience becomes more focused on the research of the system but the lack of consideration of user psychological and cognitive factors. Therefore, the human thinking and mental aspects of the user experience to further research is a big issue to explore it.

Buchholz defined QoC (Quality of Context) as quantitative indicators to describe the information of quality for any user (Buchholz, Küpper, & Schiffers, 2003). They discussed what QoC is, what its most important parameters are and how QoC relates to QoS (Quality of Service) and QoD (Quality of Device). These three notions of quality

#### **Contribution of this paper to the literature**

- This research helps to complete the quantitative assessment and psychological adjustment strategy prediction for e-Learning users' psychological experience.
- It is hoped that the results of this study can be used instead of expert assessment which can provide suggestions for studying the characteristics of users' psychological experience.
- This paper provides a reliable path for solving the quality problems of user experience when receiving services.

are unequal, but not unrelated. Based on several examples they showed the interdependence between them. Manzoor proposed the objective and subjective view of distinguishing QoC (Bellavista, Corradi, Fanelli, & Foschini, 2012). They pointed out that the evaluation of user experience quality should be defined and measured according to the consumer's needs and expectations. Bellavista presented a unified architectural model and a new taxonomy for context data distribution by considering and comparing a large number of solutions. In addition, Sheikh etc., identified and defined five quality-of-context indicators for context-aware middleware, and discuss different alternatives for their quantification (Sheikh, Wegdam, & Sinderen, 2007). These quality-of-context indicators are: precision, freshness, spatial resolution, temporal resolution and probability of correctness (Manzoor, 2010).

On the basis of previous research, this paper gives a quantitative analysis method from the perspective of user psychological experience, the key issues including E-learning application background (Harrati, Bouchrika, Tari, & Ladjailia, 2016):

1. The characteristics and factors that affect the psychological experience of E-learning users;
2. The quantitative measurement of features and elements;
3. The overall construction and experimental analysis of the quantitative model of user's psychological experience;
4. Construct a quantitative model of learners' personality and emotion regulation strategies.

The rest of this paper is organized as follows: Section 2 describes the related research work; Section 3 introduces the E-learning user psychological experience of the quantitative evaluation model; Section 4 introduces the E-learning user psychological emotion regulation strategy model. Section 5 the empirical quantitative evaluation model and emotion regulation prediction model of E-learning users' psychology were tested and analyzed. Finally, some conclusions and future works are drawn.

## **RELATED WORKS**

### **Factors of Influencing Mental Experience for User**

Researchers in psychology, sociology and computer science have made qualitative and quantitative research on the factors that influence the quality of user experience from different focuses (Aparicio, Bacao, & Oliveira, 2016; Chu, & Chen, 2016; Sinclair, Kable & Levettjones, 2016). In the qualitative aspects, some researchers believe that the influence factors of user experience can be divided into surface layer, frame layer, structure layer, layer and layer micro scope of strategic factors affect user experience is divided into service content, reconstruction and expression. In quantitative aspect, the researchers propose some quantitative indicators to measure the user experience, such as Lewis (1995) introduces a set of questionnaires for different phases of usability evaluation: one for collecting immediate user response after a task in a usability test (After Scenario Questionnaire ASQ), another for post-study evaluation for usability tests (Post Study System usability questionnaire PSSUQ) and the third for field studies (Computer System Usability Questionnaire CSUQ). The measurements have been developed by IBM. Two questionnaires were used to analysis of the effectiveness of information system quality, interface quality and overall satisfaction (Ortigosa et al., 2014). Arnie Lund designed effectiveness, satisfaction, learnability and usability questionnaire (USE) including 30 score items (Broekens & Brinkman, 2013).

The overall results show that the factors affecting the quality of user experience including:

1. It's easy to use, which can be further refined as the response speed and easy to learn, easy navigation, simple operation, favorable operation, visual appeal and other factors.
2. It can be further refined to meet the needs of users, improved the work efficiency of users and brought the value of user.
3. Some other factors can be used for user experience such as the character of the user, the user's personal information and the user emotional factors.



From the user's cognitive and emotional characteristics of the user experience has become a hot topic in this field, such as usability consideration of user cognition, behavior, psychology and qualitative research method of psychological measurement. But there is lack of quantitative evaluation methods and experimental verification in practice.

### **Quantitative Measurement of Factors**

We can obtain user needs, habits and other information from man-machine interaction and interface by observation, interview, questionnaire survey, user role play simulation and other methods to analyze the psychological characteristics of the user. This method is relatively direct and easy to operate that is mostly used in qualitative measurement but they need to spend time, use a lot of manpower and is subject to the human subjective factors (Clark, & Wrona, 2016; Reyes-Aguilar, & Barrios, 2016).

The user experience is an individual behavior which can't be completely simulated and reproduced. But there are a lot of psychological characteristics in common from the user group. Most users can be reached satisfaction through psychological common characteristics and different application of user experience services.

Some quantitative methods have been generated through user experience research such as GOMS method, CPM-GOMS method and NGOMSL method which all focus on operating time.

### **Construction of User Experience Model**

The comprehensive evaluation method of user experience quality mainly includes Grey Relational Analysis (GRA) and Analytic Hierarchy Process (AHP). Grey relational analysis (GRA) is one of the most widely used model in grey system theory. It is a method to judge the degree of correlation between factors based on the similarity degree of geometric shape of each factor (Li, Wen, & Xie, 2015; Lin & Lin, 2002; Malek, Ebrahimnejad & Tavakkoli-Moghaddam, 2017). The basic idea of grey relational analysis is to carry out dimensionless processing of the original number of evaluation indicators, calculate correlation coefficient and correlation degree, and rank the evaluation index according to the degree of correlation, so it is suitable for the comparative analysis of multiple versions of service system.

The AHP is a structured technique for organizing and analyzing complex decisions, based on mathematics and psychology (Dong, & Herrera-Viedma, 2017; Wang, Sharkh, Chipperfield & Cruden, 2017; Zhou & Xu, 2016). Users of the AHP first decompose their decision problem into a hierarchy of more easily comprehended sub-problems, each of which can be analyzed independently. Decision makers establish relative weight calculation and consistency check by establishing the hierarchical structure of analysis objectives and constructing the 22 comparison judgement matrix of element weights, and get the relative importance of each element. Therefore, the analytic hierarchy process (AHP) is suitable for single system analysis.

### **User Emotion Regulation Strategy**

Emotion is any conscious experience characterized by intense mental activity and a high degree of pleasure or displeasure. Emotions are complex. According to some theories, they are states of feeling that result in physical and psychological changes that influence our behavior (Dyson & Renk, 2006; Hannigan, Edwards, & Burnard, 2004). The physiology of emotion is closely linked to arousal of the nervous system with various states and strengths of arousal relating, apparently, to particular emotions. Emotion is also linked to behavioral tendency. Extroverted people are more likely to be social and express their emotions, while introverted people are more likely to be more socially withdrawn and conceal their emotions. Emotion is often the driving force behind motivation, positive or negative. According to other theories, emotions are not causal forces but simply syndromes of components, which might include motivation, feeling, behavior, and physiological changes, but no one of these components is the emotion (Chang, Liang, Chou & Lin, 2017; Chen, Yen, & Hwang, 2012). Nor is the emotion an entity that causes these components. At present, the research based on the relationship between emotion regulation strategy and personality is mainly qualitative analysis of a character and strategy in personality. But past studies did not explain the qualitative research of the application background and emotion research mostly took western people as subjects.

## **QUANTITATIVE EVALUATION MODEL OF E-LEARNING USERS' PSYCHOLOGICAL EXPERIENCE**

In this paper, user's psychological experience is defined as the degree of the psychological feeling of the user in receiving the service (Hwang, Al-Arabi, Shin, & Lee, 2016; Kebritchi, Hirumi, & Bai, 2010; Lee, 2010; Liu & Huang, 2015). The overall framework of the quantitative evaluation method of user's psychological experience is shown in

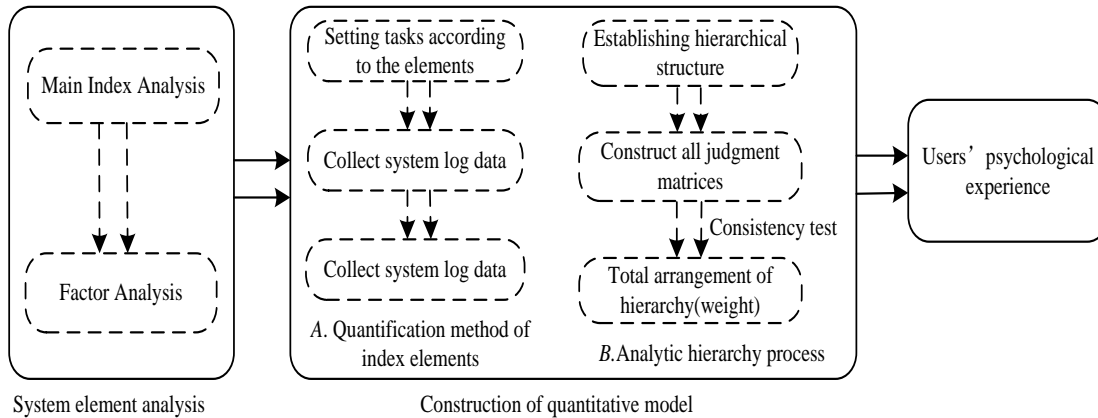


Figure 1. Overall framework of the quantitative evaluation method of user's psychological experience in E-learning

Figure 1. As shown in Figure 1, the overall idea of the quantitative evaluation method of user psychological experience is divided into three parts: (1) analysis of system elements. The main evaluation indexes are selected according to the psychological experience characteristics of the users, and the factors of the evaluation indexes are analyzed. (2) Quantitative model construction. First, according to the evaluation index, a hierarchical structure is established to determine the weight of each evaluation index. Secondly, set tasks according to the elements, collect log data and quantify the elements. (3) User psychological experience decision. Combined with the weight of each index, the quantitative results of the index factors evaluate the user's psychological experience.

### Characteristic analysis and quantization method of the quality of user's experience (QoE)

From the analysis of the previous section we can see, there are many factors that affect the user's experience, among which the most important is the usefulness and usability.

#### Usefulness

The degree of satisfaction of users to the service provided and recommended by the system is called usefulness, also called validity, which has the following 3 characteristics:

1. Resource coverage rate. It means, to which extent the resources provided by the system can cover the domain of knowledge learned by the user.

2. Recommended hit rate. The hit rate is defined as the ratio of hit times and recommendation times in the process of login. And when the user finishes the content recommended by the system, the recommendation is considered to be a hit when the evaluation of the content is greater than the corresponding threshold. As for the recommended hit rate, it is the ratio of the total number of hits to the recommended content of the system and the total number of recommended content of the system, namely

$$\alpha_H = \frac{n_s}{n_r} \tag{1}$$

3. User loyalty. It is defined as the degree of willingness of users to reuse the system, and can be measured by the frequency of user visits. If the number of users using the system per week is  $n_u$ , and the number of loyalty benchmarks based on experts' experience is  $N$ , we have

$$\alpha_L = \begin{cases} 1 & n_u \geq N \\ \frac{n_u}{N} & n_u < N \end{cases} \tag{2}$$

#### Usability

When users master the operation, learning, navigation and use of the service provided by the system, the degree of difficulty in accordance with the user's habits is called usability. Usability of the E-learning system can be reflected by the following characteristics:

1. Response speed. The response time is a time interval between the user requests the service and the system render the request service, which can be obtained by analyzing the system log record

$$v = \begin{cases} 1 & \bar{t}_{re} \leq t_{ts} \\ \frac{t_{ts}}{\bar{t}_{re}} & \bar{t}_{re} > t_{ts} \end{cases} \quad (3)$$

where,  $t_{re}$  is the response time, is the time of the user logging into the system control and loaded;  $t_{ts}$  denotes the reference response time. And user login system time is  $t_{in}$ , the time when system control is loaded is  $t_s$ , so

$$t_{re} = t_s - t_{in} \quad (4)$$

2. Navigation definition

$$\alpha_c = \frac{N_k}{M} \quad (5)$$

where,  $M$  is the number of knowledge items accessed by the user when the task is successfully completed;  $N_k$  means the number of knowledge items succeed in learning. If the user finds the target directly, the navigation definition will be 100%; if not, then the navigation definition will be 0%. Therefore, it can be seen that the smaller the system navigation, the better the user can directly and easily find the target knowledge items.

3. Task completion efficiency

$$E_T = \frac{\sum t_{ek}}{\sum t_{en}}, e_k \in E \quad (6)$$

where,  $t_{ek}$  is the length of learning time, namely, the time from the user clicks the  $k$ -th knowledge item  $e_k$  to the next knowledge. It is also the time of the user learning knowledge item  $e_k$ ;  $t_{en}$  means the time spent by the user in learning the  $n$ -th knowledge of  $N$  knowledge items;  $E$  denotes the target knowledge item set, namely a collection of knowledge items that users need to learn in a learning task,  $E = \{e_1, e_2, \dots\}$ .

In E-learning system, learning resources are provided to users by means of knowledge items. The minimum time of the user in learning the corresponding target knowledge item is  $t_{ekm}$ . If  $t_{ek} < t_{ekm}$ , it suggests that the user does not complete the learning task of the knowledge item. The minimum time is defined by the teacher expert or by referring to the average learning time of the user group.

If user's length of learning time  $t_{ek}$  is longer than  $t_{ekm}$ , namely  $t_{ek} > t_{ekm}$ , and the user thinks he/she has successfully learned the knowledge, namely the learning of knowledge item  $e_k$  is successful, the function assignment is 1; otherwise it is 0, namely

$$S_{ek} = \begin{cases} 1 & t_{ek} \geq t_{ekm} \\ 0 & t_{ek} < t_{ekm} \end{cases} \quad (7)$$

If the user successfully learned the  $N$  knowledge item in  $E$ , then think that they completed the learning task, the function assignment is 1; otherwise it is 0, namely

$$T_{S_{ek}} = \begin{cases} 1 & \sum S_{ek} \geq N, e_k \in E \\ 0 & \sum S_{ek} < N, e_k \in E \end{cases} \quad (8)$$

The task time is a period from the task loaded to the completion of the task successfully, namely

$$t_T = \sum t_{en} \quad (9)$$

### An Overall Quantitative Model of E-learning User's Psychological Experience

Analytic hierarchy process (AHP) is a decision making method for qualitative and quantitative analysis, which decomposes the elements related to decision-making into goals, criteria, plans and so on. It is a simple, practical and effective method for decision analysis and comprehensive evaluation of complex problems with multi objectives, criteria, factors and levels. Based on this, this paper applies the analytic hierarchy process (AHP) to the overall quantification of E-learning user's psychological experience.

#### *Hierarchical structure of user's psychological experience*

User's psychological experience is a kind of overall and subjective psychological feeling when users use E-learning system to study. From the above content can be seen, the overall user experience quality can be reflected in the usefulness, usability and other characteristics, which can be further refined. The hierarchical structure of the quality of mental experience in E-learning system is shown in [Figure 2](#).

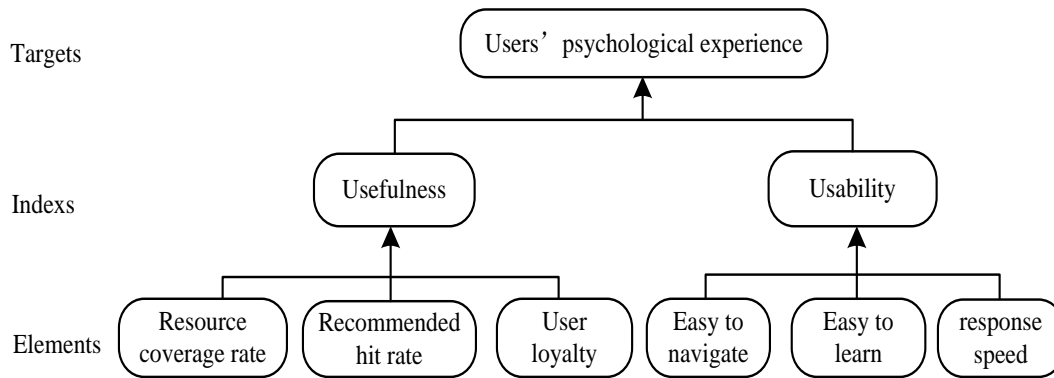


Figure 2. Hierarchical structure of user's psychological experience

Table 1. 1-9 scale method

Scale	Definition
1	equally important
3	slightly important
5	obvious important
7	strongly important
9	extremely important
2, 4, 6, 8	Denote the median of 1-3, 3-5, 5-7, 7-9 adjacent judgments respectively

Table 2. Weight judgment matrix of each sub feature of usefulness index

Usability Index	Resource Coverage Rate	Recommended Hit Rate	Loyalty
Resource Coverage Rate	1	3	1/3
Recommended Hit Rate	1/3	1	1/5
User Loyalty	3	5	1

Table 3. Weight judgment matrix of each sub feature of usability index

Usability Index	Response Speed	Navigation Definition	Task Completion Rate
Response Speed	1	1/5	1/3
Navigation Definition	5	1	3
Task Completion Rate	3	1/3	1

Table 4. The relative weight matrix of the second level index to the first level target

Index	Usability	Usefulness
Usability	1	3
Usefulness	1/3	1

### Constructing all judgment matrices at all levels

The discriminant matrix represents the relative importance between the underlying factor and its related elements in the upper layer, and determined by the mutual comparison between elements, namely, under a certain index, the feature of high weight is obtained by comparing 2 arbitrary features. And the scale of 1~9 is used to measure the comparison (Table 1).

As for usefulness, the weighting matrix is shown in Table 2.

As for usability, the weighting matrix is shown in Table 3.

The relative weight matrix of the second level index to the first level target is shown in Table 4.

### Hierarchical single ordering and its consistency check

The solution  $W$  of the eigenvalue problem  $AW = \lambda_{\max}$  of the judgment matrix  $B$ , after normalization, it is the rank weight of the relative factors of the same level to the relative importance of the upper level. The process is called the hierarchical single order.

**Table 5.** The relationship between random consistency index and matrix order

$n_A$	1	2	3	4	5	6	7	8	9
RI	0.00	0.00	0.58	0.90	1.12	1.24	1.32	1.41	1.45

**Table 6.** Hierarchical total ordering

	Usefulness	Usability	Total Ordering Weight
	0.75	0.25	
Resource Coverage Rate	0.2583	0	0.1937
Recommended Hit Rate	0.1047	0	0.0785
User Loyalty	0.6371	0	0.4775
Response Speed	0	0.1047	0.0262
Navigation Definition	0	0.6371	0.1592
Task Completion Rate	0	0.2583	0.0646

The judgment matrix needs to be acquired by the expert’s experience. Because of their different views, the weight judgment matrix needs to be checked by consistency. When the judgment matrix cannot be guaranteed to be completely consistent, the eigenvalue of the corresponding judgment matrix will change, and the consistency of the judgment can be checked by the change of the eigenvalue of the judgment matrix. Therefore, in the analytic hierarchy process, the consistency index of the judgment matrix check is

$$C = \frac{\lambda_{max} - n_A}{n_A - 1} \tag{10}$$

where,  $\lambda_{max}$  is the largest eigenvalue of matrix A;  $n_A$  denotes the order of matrix. When the matrix is inconsistent,  $\lambda_{max} > n_A$ , the greater the difference  $\lambda_{max} - n_A$ , the greater the error, that is, the greater the  $n_A$ , the poorer the consistency. In order to eliminate the influence of order on consistency test, the random consistency index R is introduced, as shown in **Table 5**.

When the order is greater than 2, the ratio of the consistency index of the judgment matrix C and the average random consistency index RI of the same order is called the random consistency ratio, which is denoted as CR. When  $CR = \frac{C}{RI} < 0.1$ , it is believed that the judgment matrix has satisfactory consistency, otherwise, the elements in the matrix need to be modified so that the importance of the elements is relatively balanced. After the consistency test, the relative weight of each feature can be obtained by normalizing the corresponding eigenvectors of  $\lambda_{max}$ .

As for the usability index,  $\lambda_{max} = 3.0386$ ,  $C = 0.0192$ , corresponding to **Table 2**,  $R = 0.52$ , corresponding to **Table 5**, then  $CR = 0.036 < 0.1$ , which shows that the matrix has passed the consistency test. Eigenvectors  $W' = [0.3715, 0.1506, 0.9161]$  corresponding to  $\lambda_{max}$ , the normalized eigenvector  $W_1 = [0.2583, 0.1047, 0.6371]$ , where the numerical value corresponds respectively to the relative weight of the resource coverage rate, the recommended hit rate and user loyalty of the usefulness index. Similarly, as for the usability index,  $CR = 0.037 < 0.1$ , satisfying consistency test, the normalized eigenvector  $W_2 = [0.1047, 0.6371, 0.2583]$ , the numerical values correspond respectively to the relative weight of the response speed, the navigation definition and the task completion efficiency of the usability index. Similarly, in **Table 4**, the relative weight of the second layer index layer relative to the first layer target layer is  $W_3 = [0.75, 0.25]$ .

### Hierarchical total ordering and its consistency test

From the previous section, the relative weight of all the elements in each layer of the hierarchy to the total target is obtained, as shown in **Table 6**.

Next, with

$$CR = \frac{\sum_{j=1}^m CI(j)a_j}{\sum_{j=1}^m RI(j)a_j}, j = 1, 2 \tag{11}$$

The consistency check of the total rank weight matrix is further carried out. It can be seen from the last section,  $CI(1) = 0.01925$ ,  $CI(2) = 0.01925$ ,  $RI(1) = 0.52$ ,  $RI(2) = 0.52$ , by(11),  $CR = 0.037 < 0.1$  can be got, which shows that the quality feature weight matrix of the whole user mental experience is tested and has satisfactory consistency.

## PREDICTION MODEL OF E-LEARNING USER’S PSYCHOLOGICAL EMOTION REGULATION STRATEGY

The relationship between learners’ personality and emotion regulation strategies can be expressed by 6 tuple

$$L = \langle U, V, W, X, Y, f \rangle \tag{12}$$

where,  $U$  symbolizes the whole set of learners;  $X$  means the attribute set of learners' personality characteristics;  $Y$  denotes the set of learners' emotion regulation strategies;  $W$  represents learner's feature set, and  $W = X \cup Y$ ;  $V$  is the predicted emotion regulation strategy set,  $V = \bigcup_{y \in Y} v_y$ , in which  $v_y$  is the value of  $y \in Y$ ;  $f: U \times W \rightarrow V$  refers to the feature mapping function of learners, and any entity  $w \in W$  in  $U$  corresponds uniquely to  $V$ .

### An Overview of Partial Least Squares Regression (PLS)

In the general multivariate linear regression model, there is a set of dependent variable  $Y = \{y_1, y_2, \dots, y_q\}$  ( $q$  is the number of dependent variables) and independent variable  $X = \{x_1, x_2, \dots, x_m\}$  ( $m$  is the number of independent variables), when the data satisfies the Gauss Mark off theorem, according to the least square method, we have

$$B = X(X^T X)^{-1} X^T Y \tag{13}$$

where,  $B$  is the estimated regression coefficient. When the variables in  $X$  have serious multiple correlations (the physical meaning of variables determines their correlation, or is caused by the insufficient number of sample points), determinant  $(X^T X)$  in formula 13 is close to zero. Therefore, there will be serious rounding errors when solving  $(X^T X)^{-1}$ , making the sampling variability of the estimation of regression coefficient increase significantly. What is more, when the variables in  $X$  are completely correlated,  $(X^T X)$  will be an irreversible matrix, unable to solve regression coefficient. At the same time, if the least square method is used to fit the regression model, there will be many abnormal phenomena in the regression result, which will not guarantee the accuracy and reliability. In practical work, the multiple correlations of variables are universal. Partial least square (PLS) method can solve this kind of problem better.

Partial least squares regression (PLS) is the integration and development of multiple linear regression, canonical correlation analysis and principal component analysis. This method first extracts component  $t_h$   $h = (1, 2, \dots)$  from the independent variable set  $X$ , each component is independent of each other. Next, establish regression equations between these components and independent variable  $X$ , the key to which is the extraction of components. Different from the principal component regression, the components extracted by partial least squares regression can not only generalize the information in independent variable system, but also explain the dependent variable best and eliminate the noise interference in the system. Therefore, the model of regression modeling is effectively solved under the condition of multiple correlations between independent variables.

### Emotion Regulation Strategy Prediction Model

At present, there are many categories of personality characteristics. Considering the age distribution of learners, and combining the mature evaluation technology with existing research results, 16 personality characteristics defined by the cartel is adopted in this paper, and the learner's personality is divided into 16 attributes, they are sociability, intelligence, stability, strength, excitability, perseverance, social boldness, sensitivity, suspicion, fantasy, sophistication, anxiety, experiment, independence, self-discipline and tension, which are defined as  $P = [A_1, A_2, \dots, A_{16}]$ , the elements in the vector represent the 16 dimensions of the above characters respectively. At the same time, this paper adopts Gross strategies of emotion regulation and divides emotion regulation strategies into depressed expression and cognitive reappraisal, which can be shown as  $T = [R, S]$ , the Chinese version of CERQ has been proved to have good applicability.

The collected data were standardized, and the personality characteristics of learners and the emotion regulation strategies of learners are independent variables and dependent variables respectively, which are presented as  $X = [x_1, x_2, \dots, x_{16}]$  and  $Y = [y_1, y_2]$ . Using partial least squares regression method, the algorithm of emotional strategy modeling based on personality strategy is as follows

**Input:** Learner personality matrix  $X = [x_1, x_2, \dots, x_{16}]$  and he emotion regulation strategy of learners  $Y = [y_1, y_2]$ .

**Output:** Prediction model of learners' emotional strategies  $y = \alpha + \beta_i x$ .

(1) Standardize the matrix of the individual personality  $X$  and the emotion adjustment strategy  $Y$ , and obtain the standardized independent variable matrix  $E_0$  and dependent variable matrix  $F_0$ .

(2) Based on the maximum eigenvalue  $\theta_1^2$  of the matrix  $E_0^T F_0 F_0^T E_0$  and the corresponding eigenvector  $\omega_1$ , the components representing the learner's individuality  $t_1 = \omega_1^T X$ , the score vector  $\hat{t}_1$  ( $\hat{t}_1 = E_0 \omega_1$ ) and the residual matrix  $E_1 = E_0 - \hat{t}_1 \chi_1^T$ ,  $\chi_1 = \frac{E_0^T \hat{t}_1}{\|\hat{t}_1\|^2}$  are obtained. Meanwhile, the eigenvector  $\omega_2$  corresponding to matrix  $E_0^T F_0 F_0^T E_0$ , the component of the emotion strategy  $\gamma_1$  ( $\hat{\gamma}_1 = F_0 \omega_2$ ), the score vector  $\hat{\gamma}_1$  and the residual matrix  $F_1 = F_0 - \hat{\gamma}_1 \beta_1^T$ ,  $\beta_1 = \frac{E_0^T \hat{\gamma}_1}{\|\hat{\gamma}_1\|^2}$  are also gained.

(3) Cross validation test, when  $Q_h^2 < 0.0975$  meets the precision requirements, the algorithm terminates, otherwise it continues.



**Table 7.** The minimum time length of the learners to complete the target knowledge item

	<b>Knowledge Unit</b>	$t_{ekm}(s)$	$\hat{t}_{ek}(s)$		<b>Knowledge Unit</b>	$t_{ekm}(s)$	$\hat{t}_{ek}(s)$
<b>1</b>	equivalent transformation of circuit	3	6	<b>9</b>	2 equivalent transformation of real circuit	8	16
<b>2</b>	series and parallel connection of resistance	1	3	<b>10</b>	circuit diagram	8	16
<b>3</b>	Y circuit of resistance	6	12	<b>11</b>	KCL independent equation	6	16
<b>4</b>	$\Delta$ circuit of resistance	6	3	<b>12</b>	KVL independent equation	10	20
<b>5</b>	series connection of voltage source	3	7	<b>13</b>	branch current method	11	22
<b>6</b>	parallel connection of voltage source	5	11	<b>14</b>	mesh current method	12	24
<b>7</b>	series connection of current source	3	7	<b>15</b>	loop current method	12	25
<b>8</b>	parallel connection of current source	6	13	<b>16</b>	node voltage method	14	28

**Table 8.** The learner log results of the E-learning system

ID number	2013
User identification	324
User name	1601082014
Knowledge unit	branch current method
Log in time	2017-09-04,19:12:34
Log out time	2017-09-04,19:13:37
Time Length/s	63

(4) Because of the rank  $r$  of  $E_0$ ,  $r \leq \min(n - 1, m)$ , there may exist  $r$  components  $t_1, t_2, \dots, t_r$ , residual matrix  $E_1$  and  $F_1$  replace  $E_0$  and  $F_0$ , and repeat the steps above.

(5) Regress of  $r'$  components  $t_1, t_2, \dots, t_{r'}$  extracted in  $F_0$ , and get ordinary least square regression equation  $F_0 = \hat{t}_1\beta_1^T + \hat{t}_2\beta_2^T + \dots + \hat{t}_{r'}\beta_{r'}^T + F_{r'}$ .

(6) As  $\omega'_k = \prod_{j=1}^{h-1} (I - \omega_j \alpha_j^T) \omega_h$ ,  $t_k = \omega'_{k1}x_1 + \omega'_{k2}x_2 + \dots + \omega'_{km}x_m$  ( $k = 1, 2, \dots, r'$ ), plug  $Y = t_1\beta_1 + t_2\beta_2 + \dots + t_{r'}\beta_{r'}$ , and the partial least squares regression equation  $y_j = \alpha_{j1}x_1 + \alpha_{j2}x_2 + \dots + \alpha_{jm}x_m$  of emotion regulation strategy dependent variables of  $p$  was obtained, the algorithm terminates.

## EXAMPLE VERIFICATION AND ANALYSIS

### Quantitative Analysis of E-learning User's Psychological Experience

By using this method, this paper analyzes the user's psychological experience of E-learning system in the course of the third grade of a university, in which 113 learners are randomly sampled. In the experiment, the learning task required by participants is to learn 2 equivalent knowledge units: equivalent transformation of resistance circuit and general analysis of resistance circuit in E-learning system.

#### Definition of successful completion of learning tasks

To complete the 2 learning tasks above, it is necessary to learn the target knowledge item set E, E=[Equivalent transformation of circuit, series and parallel connection of resistance, Y circuit of resistance, delta circuit of resistance, series connection of voltage source, parallel connection of voltage source, series and parallel connection of current source, two equivalent transformations of real circuit, circuit diagram, KCL independent equation, KVL independent equation, branch current method, mesh current method, loop current method, and node voltage method].

Assume that the minimum time length of a learner to complete a target knowledge item is equal to half of the average length of time that the learner group studies the knowledge item, as shown in Table 7. According to the expert experience, if the learners successfully learn 4 knowledge items in E, the learning task is completed successfully. N=3 is the frequency of learners using E-learning system per week, the reference response time is 10s.

#### Quantitative evaluation of data acquisition and user's psychological experience

Based on the above learning tasks, the learner log results of the E-learning system are collected, as shown in Table 8.

Next, using the above-mentioned analytic hierarchy process, and starting from the usefulness and usability, we construct the overall quantitative evaluation model of user psychological experience quality, so as to obtain the

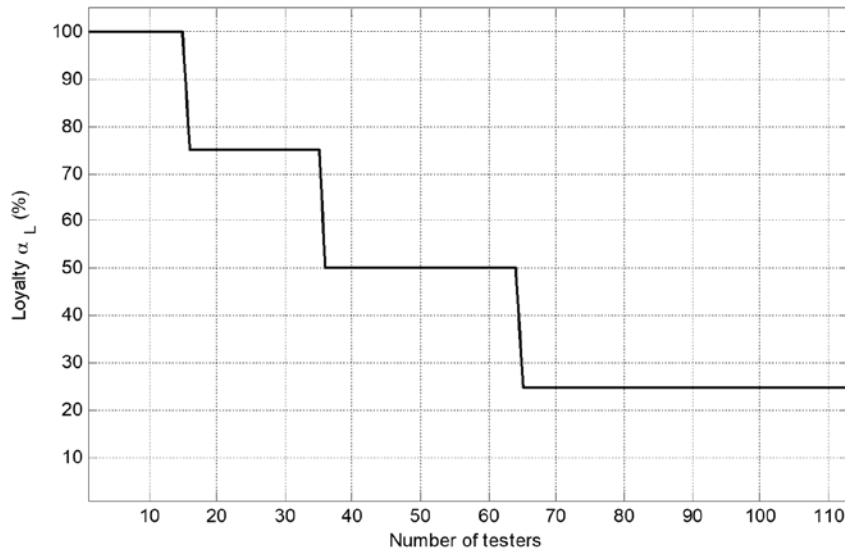


Figure 3. User loyalty

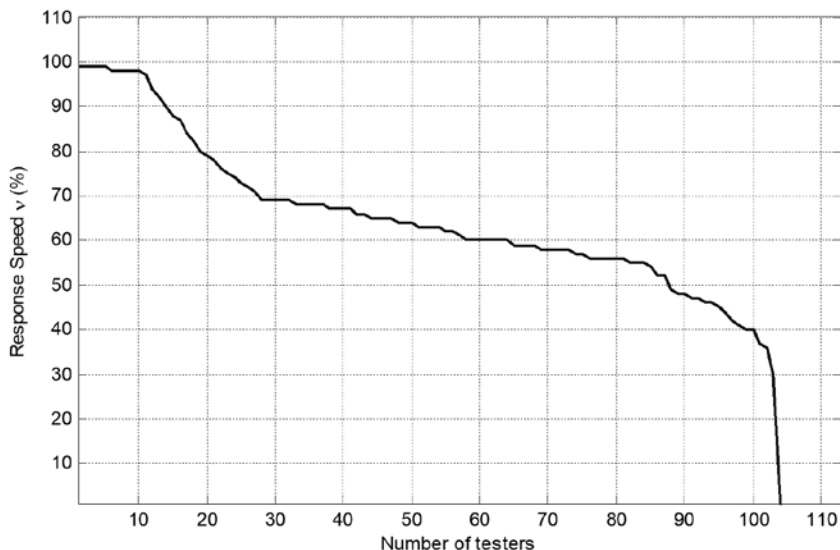


Figure 4. Response speed

resource coverage rate, recommended hit rate, user loyalty, response order weight speed, navigation definition and task completion efficiency, which were 0.1937, 0.0785, 0.4775, 0.0262, 0.1592, 0.0646 respectively, and by the combination of consistency test, It can be seen that the feature weight matrix has satisfactory consistency.

### Experimental results and analysis

The key point of the experiment is to analyze and discuss the indexes such as user loyalty, response speed, navigation definition and task completion rate, and the total index of the user's psychological experience.

Loyalty is shown in Figure 3. From Figure 3, the average value of loyalty is 50.2%, which indicates that the system is less attractive to learners, and few users are willing to continue to use the system.

The response speed is shown in Figure 4. Seen from Figure 4, affected by the network environment, the average response time is from 35s to 80s, the mean value of the response speed is 59.8%, the system response speed for 9% users is 0%. This shows that the user has taken a shutdown measure while waiting for the system to load, so the response time cannot be obtained.

Navigation definition is shown in Figure 5. From Figure 5, the average navigation definition is 37.1%, and the navigation definition of the system for 20% users is 0%, that is, it is difficult for 20% users to find the learning knowledge items while using the system.

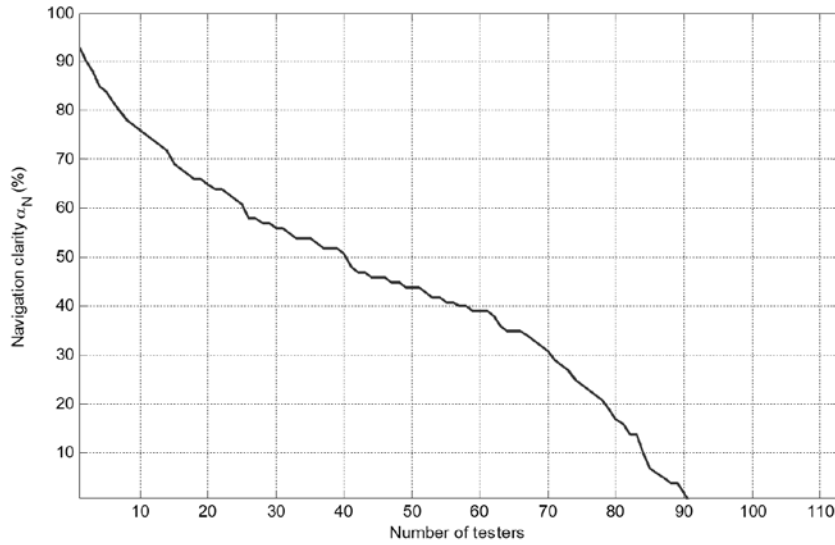


Figure 5. Navigation definition

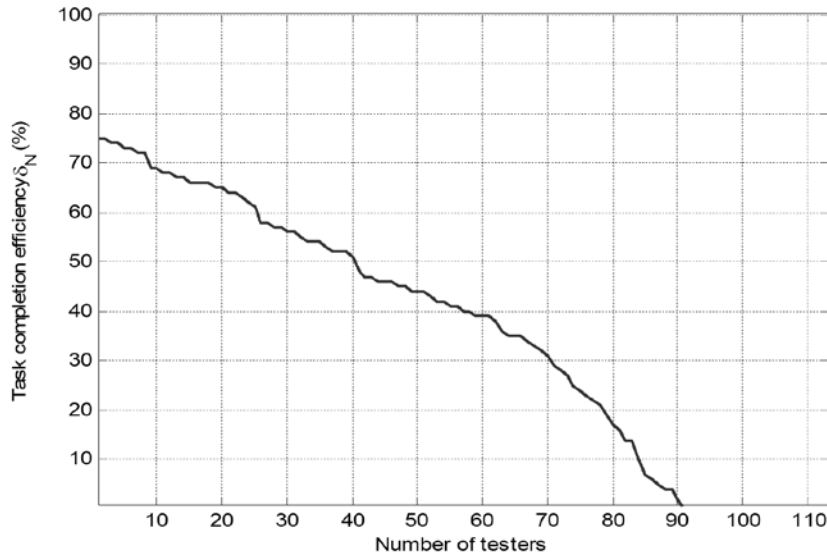


Figure 6. Task completion rate

The task completion efficiency is shown in Figure 6. From Figure 6, the average task completion rate of users when using the system is 36%, the maximum task completion rate is 75%, which shows that some users can effectively complete the learning task, but 20% users can not complete the learning task.

The overall user’s psychological experience quality that E-learning system brings to the learners is shown in Figure 7. According to Figure 7, the highest experience quality is 72%; the lowest is 27%; the average is 37.5%, which indicates that the quality of user psychological experience of E-learning system needs to be further improved.

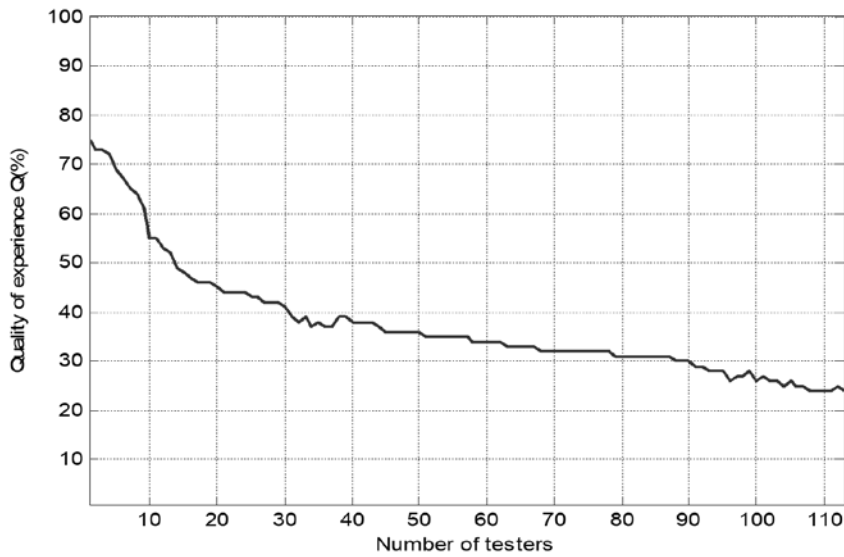


Figure 7. User experience quality

Table 9. The correlation coefficient between learners' personality and emotion regulation strategies

Attribute	correlation coefficient		Attribute	correlation coefficient	
	Repressed expression	Cognitive reappraisal		Repressed expression	Cognitive reappraisal
A <sub>1</sub>	-0.470**	0.529**	A <sub>9</sub>	0.202	0.523**
A <sub>2</sub>	0.219	0.227	A <sub>10</sub>	0.421**	-0.080
A <sub>3</sub>	0.116	0.258	A <sub>11</sub>	0.152	0.218
A <sub>4</sub>	-0.429**	0.228	A <sub>12</sub>	-0.144	0.276
A <sub>5</sub>	-0.582**	0.237	A <sub>13</sub>	-0.003	0.088
A <sub>6</sub>	0.127	0.078	A <sub>14</sub>	0.461**	-0.219
A <sub>7</sub>	-0.302*	0.336	A <sub>15</sub>	-0.092	0.105
A <sub>8</sub>	-0.112	0.261	A <sub>16</sub>	-0.159	-0.019

Notes: Data strip \* means  $p < 0.05$ , data strip \*\* in table denotes  $p < 0.01$

### E-learning User's Emotion Prediction Analysis

In order to study the relationship between learners' personality and emotion regulation strategies, this paper observed 113 learners, and form a table of the independent variable and dependent variable. The partial least squares regression is used to extract the required components on X and Y, and the emotion prediction model of personality and emotion regulation strategies are established.

#### Data preprocessing

In this paper, 113 valid samples are collected, of which 83 samples are used to establish the data set of the prediction model, and the other 30 samples are used as the sample set of the analysis and prediction model to verify the effect of the model fitting. First of all, data like personality characteristics, learners' emotion regulation strategies are preprocessed respectively, so as to gain the corresponding values. Then, the person coefficient is used to determine whether the independent variable and the dependent variable are related, and the correlation coefficient matrix is used to get the correlation between the emotion regulation strategy and the character attribute, as shown in Table 9.

From the research above and relevant data analysis, it is can be seen that in the learners' individual data, high attribute features lie in intelligence (6.084), perseverance (6.126) and self-discipline (5.978), which proves their wisdom, abstract thinking, quick thinking, responsibility, self-discipline and preciseness. The mean values of two types of emotion regulation strategies (depressive expression and cognitive reappraisal) are 2.51 and 3.168, respectively, which shows the personality and emotion regulation strategies of the learners are in line with those of the college students.

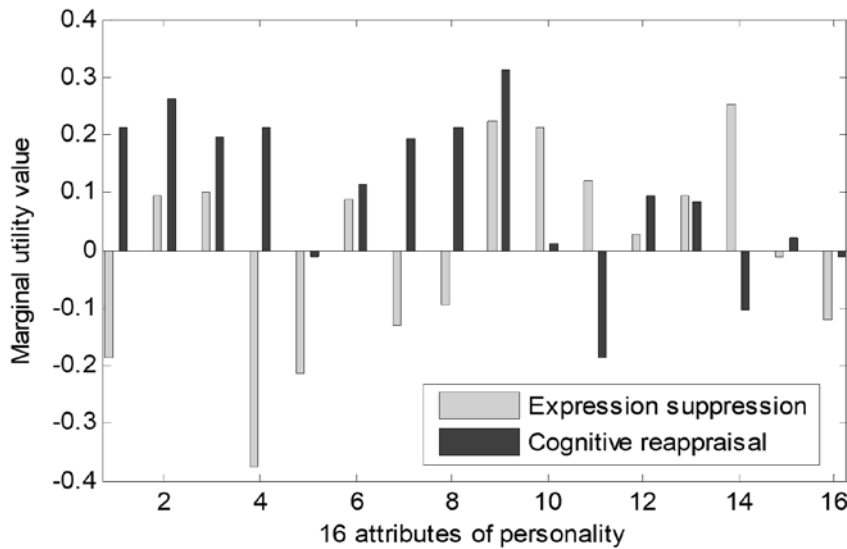


Figure 8. Regression coefficients of standardized data

### Data analysis

Based on the above data preprocessing results, the 83 samples of the effective sample set are used as the data set, and the program of partial least squares algorithm is run under the matlab2012a environment. In order to evaluate the predictive ability of the model, the cross validity is used to evaluate the model. Suppose  $Q_h^2 = -0.0178$ , According to the rule of  $Q_h^2 \geq 0.0974$ , finally, 3 components were extracted to fit, and then the depressive expression and cognitive reappraisal standardized prediction regression equation were obtained

$$\begin{aligned}
 y_r &= 0.352 + 0.075x_1 + 0.097x_2 + 0.088x_3 \dots - 0.038x_{14} + 0.019x_{15} - 0.006x_{16} \\
 y_s &= 1.667 - 0.061x_1 + 0.041x_2 + 0.057x_3 + \dots + 0.017x_{14} - 0.0131x_{15} - 0.0622x_{16}
 \end{aligned}
 \tag{14}$$

where,  $y_r$  and  $y_s$  denotes the value of repressed expression and cognitive reappraisal, the greater the value, the greater the tendency of using this emotion regulation strategy, and the value range is  $y \in [1,5]$ ;  $x_1, x_2, \dots, x_{16}$  represents the 16 dimension attributes of learners' personality in turn, Its value range is  $[1,10]$ . In this prediction model, the explanatory power of personality attributes to expression suppression and cognitive reappraisal is 72.049% and 67.862% respectively, and good accuracy is achieved.

In addition, in order to observe the importance of personality attributes in explaining emotion regulation strategies more intuitively, the histogram of regression coefficients is drawn, as shown in Figure 8, which shows, sociability, intelligence, stability, strength, sensitivity and suspicion is of great influence in cognitive reappraisal strategy; aggressiveness, suspicion, fantasy plays an important role in the interpretation of repressed expression; while experiment and self-discipline almost do not affect emotion regulation.

### Forecast analysis

Using the prediction equation set (14) established by PLS and the other 30 samples as the data set, the cognitive reappraisal and repression expression in the emotion regulation strategy are predicted. The fitting prediction based on PLS forecast values are compared with the observed values, as shown in Figure 9, we can see that all the sample points are near the diagonal distribution, prediction of the equation and the observed value are smaller, so the equation fitting effect is satisfactory.

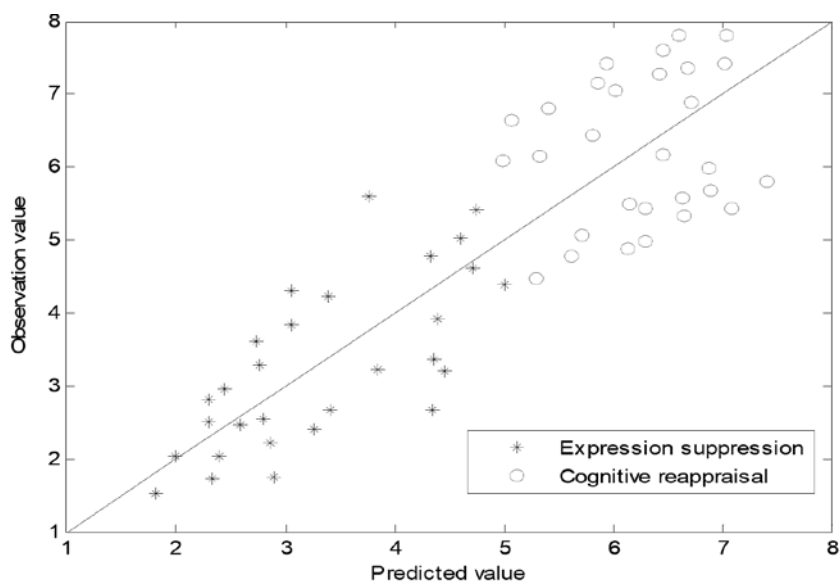


Figure 9. Predictive value and observational value of emotion regulation strategies

## CONCLUSIONS AND FUTURE WORKS

User experience research mostly focuses on the research of computer application system, which results in a research blank of user psychology, emotion, cognition and so on. This paper analyzes the characteristics of user psychological experience quality and the measurement method of selection feature quantification. Meantime, we also analyze the correlation between variables and establish the quantitative relationship between personality and emotion regulation strategies. Two conclusions have been made as following: (1) A quantitative evaluation method of user psychological experience can effectively analyze the factors that affect the quality of psychological experience of E-learning users. (2) A predictive model of emotion regulation strategy lays a theoretical foundation for designing and implementing emotion compensation system in personalized E-learning environment.

In the next step, we will continue to study other factors, such as age, family background, and so on, and establish a more perfect user experience quantitative evaluation method and emotion regulation strategy prediction model. The drawback is that this paper uses analytic hierarchy process to calculate the weight between each index. However, when there is an excessive index, the method needs to construct a deeper, larger number and larger judgement matrix, which is not conducive to consistency checking, and the exact solution of eigenvalues and eigenvectors is more complicated. In addition, the determination of judgement matrix is mostly based on the subjective experience of experts, and cannot objectively and accurately depict the fuzziness and randomness of importance among indicators.

## ACKNOWLEDGEMENTS

This work is supported in part by the Science Foundation of Ningde (Grant No.20160036), school Innovation Team of the Ningde Normal University (2015T011), project of the Fujian Provincial Natural Science Fund (Grant No. 201710016), education Department of Fujian Province under Project Number JA15556 and Youth Project of Ningde Normal University (2017Q105).

## REFERENCES

- Aparicio, M., Bacao, F., & Oliveira, T. (2016). An e-learning theoretical framework. *Educational Technology & Society, 19*(1), 292-307.
- Bellavista, P., Corradi, A., Fanelli, M., & Foschini, L. (2012). A survey of context data distribution for mobile ubiquitous systems. *Acm Computing Surveys, 44*(4), 1-45. <https://doi.org/10.1145/2333112.2333119>
- Broekens, J., & Brinkman, W. (2013). Affect Button: A method for reliable and valid affective self-report. *International Journal of Human-Computer Studies, 71*(6), 641-667. <https://doi.org/10.1016/j.ijhcs.2013.02.003>
- Buchholz, T., Küpper, A., & Schiffers, M. (2003). Quality of context: what it is and why we need it. *Proceedings of the 10th Workshop of the Open View University Association: OVUA'03*.



- Calvo, R., & D'Mello, S. (2010). Affect Detection: An Interdisciplinary Review of Models, Methods, and Their Applications. *IEEE Transactions on Affective Computing*, 1(1), 18-37. <https://doi.org/10.1109/T-AFFC.2010.1>
- Chang, C. C., Liang C. Y., Chou, P. N., & Lin, G. Y. (2017). Is game-based learning better in flow experience and various types of cognitive load than non-game-based learning? Perspective from multimedia and media richness. *Computers in Human Behavior*, 71, 218-227. <https://doi.org/10.1016/j.chb.2017.01.031>
- Chen, S. C., Yen, D. C., & Hwang, M. (2012). Factors influencing the continued intention to the usage of Web 2.0: An empirical study. *Computers in Human Behavior*, 28(3), 933-941. <https://doi.org/10.1016/j.chb.2011.12.014>
- Chu, T. H., & Chen, Y. Y. (2016). With good we become good: understanding e-learning adoption by theory of planned behavior and group influences. *Computers & Education*, 92-93, 37-52. <https://doi.org/10.1016/j.compedu.2015.09.013>
- Clark, L. M., & Wrona, S. (2016). A sensory & emotional experience: pediatric chronic pain & mental health. *Pain Management Nursing*, 17(2), 97-97. <https://doi.org/10.1016/j.pmn.2016.02.020>
- Dong, Y., & Herrera-Viedma, E. (2017). Consistency-driven automatic methodology to set interval numerical scales of 2-tuple linguistic term sets and its use in the linguistic gdm with preference relation. *IEEE Transactions on Cybernetics*, 45(4), 780-792. <https://doi.org/10.1109/TCYB.2014.2336808>
- Dyson, R., & Renk, K. (2006). Freshmen Adaptation to University Life: Depressive Symptoms, Stress and Coping. *Journal of Clinical Psychology*, 62(10), 1231-1244. <https://doi.org/10.1002/jclp.20295>
- Hannigan, B., Edwards, D., & Burnard, P. (2004). Stress and Stress Management in Clinical Psychology: Findings from a Systematic Review. *Journal of Mental Health*, June, 13(3), 236-245. <https://doi.org/10.1080/09638230410001700871>
- Harrati, N., Bouchrika, I., Tari, A., & Ladjailia, A. (2016). Exploring user satisfaction for e-learning systems via usage-based metrics and system usability scale analysis. *Computers in Human Behavior*, 61, 463-471. <https://doi.org/10.1016/j.chb.2016.03.051>
- Hwang, Y. J., Al-Arabi, M., Shin, D. H., & Lee, Y. H. (2016). Understanding information proactiveness and the content management system adoption in pre-implementation stage. *Computers in Human Behavior*, 64, 515-523. <https://doi.org/10.1016/j.chb.2016.07.025>
- Kebritchi, M., Hirumi, A., & Bai, H. (2010). The effects of modern mathematics computer games on mathematics achievement and class motivation. *Computers & Education*, 55(2), 427-443. <https://doi.org/10.1016/j.compedu.2010.02.007>
- Lee, M. C. (2010). Explaining and predicting users' continued intention toward e-learning: An extension of the expectation-confirmation model. *Computers & Education*, 54, 506-516. <https://doi.org/10.1016/j.compedu.2009.09.002>
- Lewis, J. R. (1995). *IBM computer usability satisfaction questionnaires: Psychometric evaluation and instructions for use*. L. Erlbaum Associates Inc. <https://doi.org/10.1080/10447319509526110>
- Li, Z., Wen, G., & Xie, N. (2015). An approach to fuzzy soft sets in decision making based on grey relational analysis and Dempster-Shafer theory of evidence: an application in medical diagnosis. *Artificial Intelligence in Medicine*, 64(3), 161. <https://doi.org/10.1016/j.artmed.2015.05.002>
- Lin, J. L., & Lin, C. L. (2002). The use of the orthogonal array with grey relational analysis to optimize the electrical discharge machining process with multiple performance characteristics. *International Journal of Machine Tools & Manufacture*, 42(2), 237-244. [https://doi.org/10.1016/S0890-6955\(01\)00107-9](https://doi.org/10.1016/S0890-6955(01)00107-9)
- Liu, Y. C. & Huang, Y. M. (2015). Using the UTAUT Model to Examine the Acceptance Behavior of Synchronous Collaboration to Support Peer Translation. *JALT CALL Journal*, 11(1), 77-91.
- Malek, A., Ebrahimnejad, S., & Tavakkoli-Moghaddam, R. (2017). An improved hybrid grey relational analysis approach for green resilient supply chain network assessment. *Sustainability*, 9(8), 1433. <https://doi.org/10.3390/su9081433>
- Manzoor, A. (2010). Quality of context in pervasive systems: models, techniques, and thesis, applications. *PhD School of Computer Science, Wien TU*.
- Moridis, C., & Economides, A. (2008). Toward Computer-Aided Affective Learning Systems: A Literature Review. *Journal of Educational Computing Research*, 39(4), 313-337. <https://doi.org/10.2190/EC.39.4.a>
- Ortigosa, A., Martín, J., & Carro, R. (2014). Sentiment analysis in Facebook and its application to e-learning. *Computers in Human Behavior*, 31(1), 527-541. <https://doi.org/10.1016/j.chb.2013.05.024>
- Reyes-Aguilar, A., & Barrios, F. A. (2016). A preliminary study of sex differences in emotional experience. *Psychological Reports*, 118(2), 337. <https://doi.org/10.1177/0033294116633350>

- Sheikh, K., Wegdam, M., & Sinderen, M. V. (2007). Middleware Support for Quality of Context in Pervasive Context-Aware Systems. *IEEE International Conference on Pervasive Computing and Communications Workshops* (Vol.13, pp.461-466). <https://doi.org/10.1109/PERCOMW.2007.81>
- Sinclair, P., Kable, A., & Levettjones, T. (2016). The effectiveness of internet-based e-learning on clinician behavior and patient outcomes: a systematic review protocol. *International Journal of Nursing Studies*, 57(1), 70-81. <https://doi.org/10.1016/j.ijnurstu.2016.01.011>
- Wang, L., Sharkh, S., Chipperfield, A., & Cruden, A. (2017). Dispatch of vehicle-to-grid battery storage using an analytic hierarchy process. *IEEE Transactions on Vehicular Technology*, 66(4), 2952-2965. <https://doi.org/10.1109/TVT.2016.2591559>
- Zhou, W., & Xu, Z. (2016). Asymmetric hesitant fuzzy sigmoid preference relations in the analytic hierarchy process. *Information Sciences*, 358-359, 191-207. <https://doi.org/10.1016/j.ins.2016.04.003>

**<http://www.ejmste.com>**

## An Analysis Study of the Feasibility on Offering Bachelor's Degree in Service Science

Amer Al-Badarneh <sup>1\*</sup>, James Spohrer <sup>2</sup>, Basheer Al-Duwairi <sup>1</sup>, Mohammed Shatnawi <sup>1</sup>

<sup>1</sup> Jordan University of Science and Technology, Irbid, JORDAN

<sup>2</sup> IBM Almaden Research Center, San Jose, CA, USA

Received 22 June 2017 • Revised 21 February 2018 • Accepted 21 February 2018

### ABSTRACT

The service sector is the uppermost growing stake of the developed economies. The reliance of this sector on information technology (IT) deserves revision of IT curricula. As the field of computing continues to grow and diversify, and new computing-related disciplines emerge, existing curriculum programs must be updated regularly and new computing disciplines will be drafted. The primary aims of this paper, therefore, are firstly, to introduce the emerging academic discipline known as Service Science, Management, and Engineering (SSME), in response to the growing dominance of the service sector in emerging economies. Secondly, we present a feasibility study of establishing a new undergraduate academic program that offers a Bachelor's degree in SSME. The study was based on analyzing the results of a study conducted to evaluate the workforce in Jordanian information and communications industry. The results of the study concluded that the demand for hybrid IT graduates in the knowledge-based service economy is rapidly growing.

**Keywords:** bachelor's degree, curriculum development, feasibility study, service science, SSME

### INTRODUCTION

Recently, there is an increase interest to upgrade academic programs by new disciplines. In today's knowledge-intensive economy, services represent the fastest growing portion of the world economy and the service sector has grown to a degree that it is ranked first in terms of gross domestic product as well as number of workers in all major industrialized countries (Spohrer & Maglio, 2008; Solnet, 2012). Recently, there is a "call to action" focusing educational institutes to update academic curriculum in areas related to the dominant sector of economics activity (Al-Badarneh, Spohrer, & Al-Duwairi, 2013; Chesbrough, 2004). Services contribute more than 50% of World GDP economy (Soubbotina & Katherine, 2000) and service innovation represents the main factor for revenue and profit growth.

Service science is an emerging multidisciplinary approach to study value-cocreation phenomena. It is the study of complex systems that allow us to create a better world, in which various types of service system entities (e.g., people, businesses, universities, and technologies) take actions that provide value for others. Now, service science has led hundreds of organizations and thousands of people into a remarkable preliminary investment prioritization by creating service innovation roadmaps (Spohrer & Maglio, 2010).

In the report published by the U.S. Department of Labor (Bureau of Labor Statistics, 2016) which introduces the employment figures in the United States, it shows the increase demand for the employment of people with hybrid (mixed) experience of technical and business skills (T-Shaped professionals) instead of traditional IT jobs (Beblavý, Fabo, & Lenearts, 2016; Thompson, Bellanca, Owens, & Lorenzo, 2012).

In line with this demand on service scientists locally and globally, we believe, Jordan in general and the University of Science and Technology (JUST) in particular, there is a need to take appropriate initiatives and

### **Contribution of this paper to the literature**

- To take appropriate initiatives and rehabilitation of graduates and provide them with the knowledge and skills necessary to compete better in the job market.
- To develop a competent academic program that is systematically developed and reviewed to ensure that it continues to meet the needs of the fast-growing and evolving IT service-based sector.
- To present a feasibility study to illustrate the importance, rationale, and objectives of initiating a new service science undergraduate program at Jordan University of Science and Technology.

rehabilitation of graduates and provide them with the knowledge and skills necessary to compete better in the job market locally, regionally and globally. The purpose of this study is to present a feasibility study to illustrate the importance, rationale, and objectives of initiating a new undergraduate SSME program within the college of Computer & Information Technology (CIT) at JUST.

This study aims to be a catalyst for developing competent academic program of high quality that is systematically developed and reviewed to ensure that it continues to meet the needs of the fast-growing and evolving IT service-based sector in Jordan and in the region. This work was conducted based on two main activities, which are: (1) Reviewing existing SSME programs locally, regionally, and internationally to have a clear perception of others' experiences in offering programs in service science. This includes the academic as well as the organizational aspects of the existing program. (2) Analyzing the results of a study conducted by Ministry of Information and Communications Technology (ICT) of Jordan entitled "Workforce in Jordanian ICT Industry: Evaluation and Needs Assessment 2010" (Ministry of Information and Communications Technology [MoICT], 2010).

## **BACKGROUND**

### **Overview of SSME**

Service Science, Management, and Engineering (SSME) is a term introduced recently by IBM, highlighting the need for a multidisciplinary approach to service innovation (Spohrer & Kwan, 2009). SSME is a multi-disciplinary program to the study, design, and implementation of services systems. It combines studies in disparate fields such as computer science, management, engineering, and business strategies. In these complex systems, people and technology are arranged and interact in harmony to provide value for others. In general, SSME academic curriculum should consist of three parts (Spohrer, Maglio, Bailey, & Gruhl, 2007): science, management, and engineering. Science is a way to create knowledge to: (i) understand services and their evolution, (ii) provide tools and methods to study services, and (iii) develop solutions to challenging problems. Management covers investment approaches to improve service systems; it also improves the process of creating and capturing value. Engineering is how to invent new technologies that improve the scaling of service systems; it is a way to apply knowledge and create new value.

### **SSME in Academia**

SSME is beginning to emerge in academia and it is gaining high importance and attracting the attention of leading university researchers, teaching faculty, industry people, and government officials. In fact, it is becoming a common target of many schools and universities worldwide (especially in USA and Europe). Several top U.S. and top international universities are formulating and offering professional Masters-level concentrations or degree programs containing courses related to this field.

For example, over two hundred universities in fifty countries have begun service-related academic programs, service science textbooks, books, and readings have been published worldwide (e.g., *Service Is Front Stage* (Teboul, 2006), *Service Science: Research and Innovations in the Service Economy* (Hefley, & Murphy, 2008), and *Service Management* (Fitzsimmons, Fitzsimmons, & Bordoloi, 2014)). Furthermore, there is an increasing number of related activities including, first, emerging professional associations such as International Society of Service Innovation Professionals - [issip.org](http://issip.org), second, establishing special interest groups (SIG) in service science such as Institute for Operations Research and the Management Sciences - INFORMS, finally, launching and expanding several annual conferences such as *Exploring Service Science and Frontiers in Service*.

## THEORETICAL FRAMEWORK

### Justification of Establishing SSME Program

In today's knowledge-intensive economy, it is very important that companies, governments, and universities are involved in service innovation, because GDP growth of nations, revenue, and profit growth increasingly depends on it (Daniels, 2012; Witell et al. 2016). Academia, in its turn, need to adopt and embrace services as a new discipline through adapting existing curricula and the offering of new dedicated degrees in service innovation. Furthermore, people in the academic field need to play an active and productive role in initiating frontier research in service innovation in partnership with businesses for the good of society.

Here in Jordan in general and at JUST in particular, it is in our best interest to understand, leverage, and adapt to the increasing importance of services in several business sectors. It is not only the importance of services itself, but also it is vital to focus on this field of study and to adopt it as a new discipline. This comes inline with the strategic objectives of Jordan's ICT sector (MoICT, 2013) that include:

- Promote the role of IT as a service and its potential to transform businesses to become more efficient, productive as well as improve product quality.
- Help Jordanian companies to increase their outreach in the service sector by leveraging novel Internet-based service delivery models.
- Development of applications and solutions targeted toward niche markets including healthcare, banking and gaming industry.
- Leverage Internet-based services in the educational process.
- Better align Universities outcome to industry needs by teaching students necessary and desirable skills.

Also, the research and development strategy for the ICT sector in Jordan (MoICT, 2017) pointed out a user-driven strategy for ICT sector development. Such user-driven strategy promotes software as a product and a service, which is vital for a vibrant and sustainable ICT sector. In this section, the justifications to establish the SSME academic program are presented and discussed.

### The Role of SSME Program

In Jordan, services are the largest share in IT expenditure. The 2016 ICT and IT Enabled Services (ITES) Sector Classification and Statistics Survey (MoICT, 2016) recognizes IT role beyond the supply of computer hardware and software. IT plays an increasing role in the provisioning of services over communications networks, such as the provisioning of information, applications and transaction services. Government policy on ICT also encourages companies, both within and outside of Jordan, to make online services and applications available in the Jordanian market. The following points discuss the important role that SSME will play in Jordan in general and at JUST in particular:

- The service sector has been consistently gaining a bigger portion of the total GDP of the world's biggest economies, the Jordanian economy is no exception to this phenomena. According to a study by the CIA-world Fact Book, the service sector in Jordan is the largest contributor to the Jordanian GDP with a percentage of 66.5 leaving the industrial sector and agricultural sector with only 29.9 percent and 3.7 percent, respectively. In response to this local as well as global demand we believe that Jordan University of Science and Technology (JUST) need to take the appropriate initiatives and qualify our graduates with necessary knowledge and skills to better compete in the local, regional, as well as global job market.
- At JUST, we believe that we should take a leading step and offer a dedicated SSME degree. SSME degree holders will be better aligned with the industry and job market trends. Almost all of the big players in the IT field are moving toward service-oriented and Software as a Service (SaaS) architectures including IBM, Microsoft, Google, HP, Oracle, and many others. In this architecture, every aspect of IT is being offered as a service for a fee beginning with the hardware and ending with application logic. Hardware is being offered as virtual machines (cloud computing), storage, office tools, DBMSs, operating systems and others.
- The SSME department will be the host of exceptional inter-disciplinary faculty members who are capable of conducting cutting-edge research for the benefit of the local and regional service sector. Such research will tackle all sorts of real-life problems facing the service sector. The results of such research will improve our fundamental understanding, engineering, as well as management of the local and regional service sectors.
- The SSME department will outreach to the less-developed local businesses and acquaint them with the global services trend. Furthermore, the department will help them in the transition from product-oriented businesses to service-oriented businesses.

## STUDY APPROACH

This descriptive study utilized survey research conducted by Ministry of ICT/Jordan (MoICT, 2010). To collect the data needed for this study, a structured questionnaire is utilized and distributed over a representative sample of 111 Jordanian IT companies. The majority of companies (72%) are primarily oriented toward information technology activities whereas the remaining focus on telecommunications sector. The response rate (68%) was a good proportion representing the total companies answered the questionnaire.

A weighting variable was created to take into account the selection probability and non-responses. With the above number of completions, the sampling error was calculated to be +/- 2 percentage points.

The objective of this study was to provide an incentive for the development of high quality vocational education with regularly reviewed and systematically developed curricula to ensure that the requirements of the rapidly growing ICT sector in Jordan and the region are met. The results of the study will help:

- The development of specialized academic programs in the field of technology education to meet the needs of industries and rapidly changing requirements
- Establishing high-quality professional education motivated by continuously and systematically reviewed and developed curricula.
- Aligning learning outcomes with required skills by developing training programs and workplaces.
- Enhancing partnerships and collaboration between ICT industry and academic communities.
- Implementing student-centered teaching practices to equip university graduates with appropriate skills and knowledge.

## RESULTS & DISCUSSION

In the following subsections, we present the analysis results for the needed job and technologies.

### Job Roles Importance

In the survey, companies were asked to evaluate 16 major ICT job roles using scale (1-4) in terms of existing skills, current and future relevance, and proficiency level for both current employees and new graduates. Companies were also inquired about their plans to employ new graduates for certain job roles, their plans to train them, and the availability of the training budget.

The results of the survey showed that the most important job role is the *Application Developer*, with 57% of the companies indicated that this role is of high importance now and in the future. Similarly, the job role of the *Project Manager* is also important now and in the future to 49% of the companies. The role of the *Database Administrator* is the third and most important job role, followed by *Network Service Specialist*, *Security Services Specialist*, and *System Administrator* with an assessment rate of 41% and 36% of companies, respectively. The lowest percentage in this category was for a *Packaged Application Specialist* at 19% of companies. On the other hand, results showed that the most important role now and in the future is the *Storage Services Specialist* followed by *Content Management Specialist* and *Packaged Applications Specialist*.

Regarding the job roles that are considered to be of current and future importance; *Testing Specialist* took first place with 28% of respondents, while 11% of respondents said it was of low current importance but expected to be of high importance in the future. The second place was for both *Business Analysts* and *Integration Specialist*. However, 19% of companies noted that the role of *Business Analyst* is of low importance at present but is expected to be high in the future followed by *Integration Specialist* with 15% of companies. **Table 1** shows the average importance (current and future) of all identified job roles. **Table 2** presents statistic summaries (mean, standard deviation, median, skewness, Kurtosis, and standard error) of current and future importance of job roles.



**Table 1.** Current and future importance of job roles (%)

Job Role	LOW current Importance and LOW future Importance (1)	LOW current Importance and future HIGH Importance (2)	Moderate Current Importance and future Importance (3)	Current HIGH Importance and future HIGH Importance (4)	No Answer
Portals & Collaboration	23	15	20	23	19
Packaged Application Specialist	27	13	20	19	21
Content Manager Specialist	27	19	13	28	13
Project Manager	7	11	25	49	8
Storage Services Specialist	31	15	12	20	22
Systems Programmer	12	24	16	36	12
Server Services Specialist	17	11	19	33	20
Security Services Specialist	19	13	15	36	17
Network Services Specialist	17	15	17	36	15
Infrastructure Specialist	21	16	12	35	16
Database Administrator	12	15	21	41	11
Test Specialist	16	11	28	31	14
Data Specialist	20	15	21	24	20
Integration Specialist	20	15	27	20	18
Application Developer	9	11	15	57	8
Business Analyst	11	19	27	32	11

**Table 2.** Statistic summaries of current and future importance of job roles

Job Role	Mean	S Dev.	Median	Skewness	Kurtosis	S Error
Portals & Collaboration	2.53	1.18	2.63	-0.07	-1.52	0.13
Packaged Application Specialist	2.39	1.19	2.46	0.07	-1.55	0.13
Content Manager Specialist	2.48	1.24	2.37	0.06	-1.62	0.13
Project Manager	3.26	0.95	3.56	-1.07	0.04	0.10
Storage Services Specialist	2.27	1.23	2.03	0.30	-1.55	0.14
Systems Programmer	2.86	1.11	3.00	-0.34	-1.34	0.12
Server Services Specialist	2.85	1.18	3.13	-0.49	-1.31	0.13
Security Services Specialist	2.82	1.22	3.13	-0.41	-1.46	0.13
Network Services Specialist	2.85	1.18	3.12	-0.44	-1.37	0.13
Infrastructure Specialist	2.73	1.25	2.92	-0.26	-1.60	0.14
Database Administrator	3.02	1.09	3.33	-0.67	-0.95	0.12
Test Specialist	2.86	1.11	3.07	-0.55	-1.07	0.12
Data Specialist	2.61	1.16	2.74	-0.17	-1.45	0.13
Integration Specialist	2.57	1.11	2.72	-0.18	-1.34	0.12
Application Developer	3.30	1.02	3.69	-1.17	-0.05	0.11
Business Analyst	2.90	1.03	3.04	-0.47	-1.01	0.11

### Trained Workforce Availability for Job Roles

To estimate the level of skills existing for each of the basic ICT jobs, companies were requested to rank the trained workforce available for each role of ICT by using scale ranks from 1 (unavailable) to 4 (too many). Results showed that the highest ranking in the availability of a very large number of trained workforce was for *Systems Programmer*. Three roles were ranked second: *Application Developer*, *Database Administrator*, and *Project Manager*. The third place was related to *Infrastructure Specialist*.

The lowest level was for *Test Specialist*, *Security Services Specialist*, *Storage Service Specialist*, and *Application Specialist*. *Packaged Application Specialist* has the lowest job role in terms of the availability of the trained workforce, because about one-third of the companies believe that there is no trained workforce available for this role. The second place is for *Storage Services Specialist* followed by *Portal & Collaboration Specialist* and *Content Manager Specialist*.

With regard to the jobs that companies indicated had an adequately trained workforce, the highest rank was for *Application Developer*. The second rank was *Database Administrator*. The third rank was for *System Programmers* and *Network and Services*, and the fifth place for *Project Managers*. The least job role with sufficiently available trained manpower was *Packed Application Specialist*.

**Table 3.** Availability of trained workforce of job roles (%)

Job Role	No available	Few available	Enough available	Too much available	No Answer
	trained workforce (1)	trained workforce (2)	trained workforce (3)	trained workforce (4)	
Portals & Collaboration	23	25	20	5	27
Packaged Application Specialist	32	28	9	4	27
Content Manager Specialist	23	28	19	8	22
Project Manager	11	36	29	13	11
Storage Services Specialist	28	23	16	4	29
Systems Programmer	9	28	32	15	16
Server Services Specialist	16	28	28	7	21
Security Services Specialist	19	32	24	4	21
Network Services Specialist	8	35	32	8	17
Infrastructure Specialist	19	29	23	9	20
Database Administrator	11	29	33	14	13
Test Specialist	15	35	25	4	21
Data Specialist	19	33	19	5	24
Integration Specialist	16	43	13	8	20
Application Developer	9	25	40	14	12
Business Analyst	17	44	17	6	16

**Table 4.** Statistic summaries of trained workforce of job roles

Job Role	Mean	S. Deviation	Median	Skewness	Kurtosis	S. Error
Portals & Collaboration	2.10	0.93	2.04	0.32	-0.95	0.11
Packaged Application Specialist	1.79	0.87	1.66	0.91	0.09	0.10
Content Manager Specialist	2.15	0.97	2.07	0.37	-0.91	0.11
Project Manager	2.49	0.89	2.43	0.11	-0.78	0.09
Storage Services Specialist	1.94	0.92	1.83	0.54	-0.80	0.11
Systems Programmer	2.63	0.90	2.66	-0.10	-0.82	0.10
Server Services Specialist	2.33	0.90	2.34	0.04	-0.89	0.10
Security Services Specialist	2.16	0.85	2.14	0.17	-0.81	0.10
Network Services Specialist	2.48	0.80	2.46	0.06	-0.52	0.09
Infrastructure Specialist	2.28	0.95	2.22	0.22	-0.94	0.11
Database Administrator	2.57	0.91	2.61	-0.08	-0.83	0.10
Test Specialist	2.23	0.82	2.20	0.13	-0.64	0.09
Data Specialist	2.13	0.87	2.08	0.35	-0.63	0.10
Integration Specialist	2.16	0.86	2.06	0.62	-0.15	0.10
Application Developer	2.67	0.87	2.75	-0.26	-0.60	0.09
Business Analyst	2.14	0.82	2.07	0.50	-0.16	0.09

Furthermore, we can notice that the highest ratio of job roles with few available manpower was for *Business Analyst*, followed by *Integration Specialists*, and then *Project Managers*. The lowest category was for *Storage Services Specialists*. **Table 3** shows the availability percent of the trained workforce for core job roles. **Table 4** presents statistic summaries of the trained workforce for core job roles.

### New Graduates and their Proficiency Level for Core Job Roles

For each ICT job role, companies were requested to rank the attained skills of new graduates using a four-category assessment scale (1: No skills, 2: Acquired skills, 3: Applied skills, 4: Expert skills). For the expert skill category, the companies' assessment ratios for main job roles were not high; moreover the values were concentrated with small inconsistencies, which meant small differences have been noticed among them. The highest rank in this category was for the role of *Project Manager* since 8% of the respondents pointed out that new graduates have expert skills for this role followed by *Business Analyst*. *Server Service Specialist* and *Data Specialists* were ranked third. The fourth level has acquired five job roles; *Infrastructure Specialist*, *Network Service Specialist*, *Database Administrator*, *Content Manager Specialist*, and *Test Specialist*. The lowest rate for *Packaged Application Specialist*.

As for the companies' awareness of applied skills, the highest percentage (20% of the participants) indicated that the skills of the new graduates of *System Programmer* are applied skills, while this role ranked third in terms of acquired skills. The next rank was for *Database Administrator*, while it was ranked as the fifth place in terms of gained skills, and the third for *Test Specialist*. *Server Service Specialist*, *Application Developer*, and *Data Specialist* were

**Table 5.** Proficiency level of fresh graduate (%)

Job Role	No skills (1)	Acquired skills (2)	Applied skills (3)	Expert skills (4)	No Answer
Portals & Collaboration	33	32	4	3	28
Packaged Application Specialist	37	24	9	2	28
Content Manager Specialist	33	29	9	5	24
Project Manager	33	36	11	8	12
Storage Services Specialist	31	32	4	3	30
Systems Programmer	24	37	20	3	16
Server Services Specialist	31	29	12	5	23
Security Services Specialist	29	35	11	3	22
Network Services Specialist	24	43	11	4	18
Infrastructure Specialist	31	35	9	5	21
Database Administrator	25	36	19	4	16
Test Specialist	32	29	13	4	21
Data Specialist	31	27	12	5	25
Integration Specialist	32	33	9	3	23
Application Developer	23	51	12	3	11
Business Analyst	41	29	5	8	17

**Table 6.** Statistic summaries of proficiency level of fresh graduate

Job Role	Mean	S. Deviation	Median	Skewness	Kurtosis	S. Error
Portals & Collaboration	1.68	0.77	1.59	1.15	1.29	0.09
Packaged Application Specialist	1.67	0.80	1.47	0.98	0.15	0.09
Content Manager Specialist	1.82	0.89	1.67	0.92	0.06	0.10
Project Manager	1.93	0.93	1.81	0.81	-0.21	0.10
Storage Services Specialist	1.70	0.77	1.63	1.12	1.23	0.09
Systems Programmer	2.02	0.82	1.99	0.34	-0.63	0.09
Server Services Specialist	1.88	0.90	1.76	0.76	-0.30	0.10
Security Services Specialist	1.85	0.81	1.79	0.72	-0.01	0.09
Network Services Specialist	1.94	0.79	1.90	0.70	0.26	0.09
Infrastructure Specialist	1.82	0.83	1.74	0.87	0.26	0.09
Database Administrator	2.02	0.85	1.97	0.42	-0.59	0.09
Test Specialist	1.89	0.91	1.76	0.73	-0.37	0.10
Data Specialist	1.88	0.91	1.74	0.76	-0.36	0.11
Integration Specialist	1.78	0.80	1.70	0.86	0.24	0.09
Application Developer	1.94	0.73	1.92	0.61	0.46	0.08
Business Analyst	1.76	0.94	1.52	1.17	0.44	0.10

ranked fourth. The lowest rank was for *Portal and Collaboration Specialist* and *Storage Service Specialist*, while 32% of the respondents believed that the skills available to new graduates of these two roles were acquired skills.

The results also showed that more than 40% of the respondents (the highest percentage) indicated that new graduates do not have skills of *Business Analyst*, while the second place is related to *Packaged Application Specialist*. The third level relates to *Portal and Collaboration Specialist*, *Content Manager Specialist*, and *Project Manager*. The fourth level was for both *Integration Specialists* and *Test Specialists*. *Server Service Specialist*, *Infrastructure Specialist*, *Storage Service Specialist*, and *Data Specialist* were ranked fifth. *Application Developer* was ranked, which is the highest level of acquired skills. **Tables 5** and **6** show the overall statistical analyses.

### Number of Fresh Graduates to Be Hired

Each year, there is a need to hire new employees to cover the demand and expansion of the Jordanian ICT sector. The goal of this subsection is to measure the demand volume for each job and therefore asks companies to provide their forecasts for the number of new graduates they plan to employ for each specific job role.

*Application Developer* gained the largest demand size, where all companies plan to hire as of total 256 new graduates for this role. The results revealed that all of the other jobs are required but not as much as required as the *Application Developer*. The next job required is *Project Manager* with 82 appointments of new graduates for this role, followed by *Content Manager Specialist* with 78 new graduates. While 73 graduates are needed for the role of *Business Analyst*, 64 graduates for *System Programmer*, the least is for *Storage Service Specialist* with the demand of 17 graduates. These results are consistent with the results presented in job roles important subsection. The results

**Table 7.** Fresh graduates needed to be hired for each job role

Job Role	Total	Percent %
Application Developer	256	25.2
Project Manager	82	8.1
Content Manager Specialist	78	7.7
Business Analyst	73	7.2
Systems Programmer	64	6.3
Test Specialist	59	5.8
Database Administrator	58	5.7
Network Services Specialist	55	5.4
Infrastructure Specialist	52	5.1
Integration Specialist	46	4.5
Server Services Specialist	42	4.1
Data Specialist	37	3.6
Security Services Specialist	34	3.3
Packaged Application Specialist	33	3.2
Portals & Collaboration	30	3
Storage Services Specialist	17	1.7

showed that the majority of companies (57%) believe that the role of *Application Developer* is of high importance in the present and future, and the results of this subsection reveal that this role is the most sought after. These results present a good picture of actual market needs and draw attention to the importance of bridging the gap between market forces; supply and demand. **Table 7** shows the demand volume of new graduates to be recruited for each job.

### Technologies Needed

Companies are requested to measure the current and future (over 5 years) importance of each the identified technologies through analyzing the companies' perception of each technology. For technologies that are of great importance today and in the future, *Database Systems* has the highest ratings. Followed by *Enterprise Development*, *Web Development*, and *Enterprise Resource Planning*. The latter rank was for the *Supply Chain*, while it has the highest in term of low current and low future importance.

With regard to the second set of evaluation (technologies of low current importance but expected to have high future importance). *Customer Relationship Management* gained the highest percentage of respondents, with 23% of companies indicated that this technology is of low importance at present but is expected to be of high importance in the future. The second is *Uniform Modeling Language*. The third is *Enterprise Resource Planning*, *Supply Chain*, *Business Intelligence*, and *Web 2.0*. The fourth place is *Enterprise Content Management*, while the latter was a set of two technologies: *Infrastructure Monitoring* and *Web Development*. The overall results are summarized in **Tables 8** and **9**.

**Table 8.** Current and future importance of technology skills (%)

Technology Skill	LOW current	LOW current	Moderate	Current HIGH	No Answer
	Importance and LOW future Importance (1)	Importance and future HIGH Importance (2)	Current and future Importance (3)	Importance and future HIGH Importance (4)	
Data Base Systems (Oracle, MS SQL, DB2)	3	16	27	45	9
Enterprise Development (J2EE, .Net, VB, C++)	11	12	23	37	17
Web Development (Java, Apache, PHP, ASP.Net)	19	9	24	36	12
ERP (Enterprise Resource Planning)	15	19	16	29	21
Network Security and Infrastructure (Cisco, IBM)	21	11	19	27	22
Web 2.0 (AJAX, Wikis, Social Networks)	25	19	9	23	24
CRM (Customer Relationship Management)	15	23	21	19	22
Cloud Computing & Virtualization	30	16	13	16	25
Business Intelligence (Business Analytics, DWH)	13	19	25	16	26
AIM - BPM (Business Process Management), BPEL	20	15	23	16	27
Enterprise Content Management	20	17	17	15	31
Infrastructure Monitoring (Tivoli, HP)	27	9	21	11	32
SOA (Service Oriented Architecture)	30	12	17	9	32
UML (Unified Modelling Language), RUP	28	20	16	8	28
Supply Chain Management	31	19	16	5	29

**Table 9.** Statistic summaries of current and future importance of technology skills

Job Role	Mean	S. Deviation	Median	Skewness	Kurtosis	S. Error
Web 2.0 (AJAX, Wikis, Social Networks)	3.25	0.86	3.48	-0.81	-0.42	0.09
CRM (Customer Relationship Management)	3.04	1.06	3.30	-0.73	-0.80	0.12
Cloud Computing & Virtualization	2.88	1.17	3.17	-0.56	-1.21	0.13
Business Intelligence (Business Analytics, DWH)	2.75	1.15	2.84	-0.25	-1.42	0.13
AIM - BPM (Business Process Management), BPEL	2.67	1.21	2.87	-0.26	-1.52	0.14
Enterprise Content Management	2.39	1.23	2.18	0.20	-1.59	0.14
Infrastructure Monitoring (Tivoli, HP)	2.56	1.06	2.55	-0.04	-1.26	0.12
SOA (Service Oriented Architecture)	2.20	1.19	1.97	0.38	-1.41	0.14
UML (Unified Modelling Language), RUP	2.60	1.02	2.68	-0.16	-1.13	0.12
Supply Chain Management	2.47	1.11	2.59	-0.05	-1.38	0.13
Web 2.0 (AJAX, Wikis, Social Networks)	2.39	1.13	2.35	0.12	-1.40	0.14
CRM (Customer Relationship Management)	2.24	1.15	2.28	0.18	-1.50	0.14
Cloud Computing & Virtualization	2.07	1.11	1.83	0.44	-1.30	0.13
Business Intelligence (Business Analytics, DWH)	2.06	1.03	1.90	0.50	-1.03	0.12
AIM - BPM (Business Process Management), BPEL	1.93	0.98	1.74	0.59	-0.89	0.12

### Availability of Technology Skills of Fresh Graduates

To assess the availability of technology skills of new graduates, companies were requested to rank the availability of technology skills of new graduates using a four-category assessment scale (1: No available, 2: Few available, 3: Enough available, 4: Too much). The results of the analysis showed that most companies think that majority of new graduates do not have trained workforce for most technologies. In addition, the results showed small percentage of companies that have pointed out the availability of too much ones.

The technology skill that was ranked the highest in terms of "No available" is *Cloud Computing and Virtualization*. The second is *Business Process Management*. The third is *Business Intelligence*. The fourth is *Supply Chain Management*. The fifth category is *Service-Oriented Architecture*. The last technology in terms of "No available" trained workforce is *Database Systems*.

The technology that was ranked the highest in terms of "few available" trained workforce is *Database Systems*. Pointing out that it has ranked first in terms of high current and future importance. The second rank is *Web Development*. The third is *Enterprise Development*. Ranked fourth is *Web2.0* followed by *Customer Relationship*

**Table 10.** Availability technology skills of fresh graduate

Technology Skill	No available trained workforce (1)	Few available trained workforce (2)	Enough available trained workforce (3)	Too much available trained workforce (4)	No Answer
Data Base Systems (Oracle, MS SQL, DB2)	13	40	27	8	12
Enterprise Development (J2EE, .Net, VB, C++)	15	37	19	9	20
Web Development (Java, Apache, PHP, ASP.Net)	19	39	20	7	15
ERP (Enterprise Resource Planning)	35	23	16	3	23
Network Security and Infrastructure (Cisco, IBM)	23	27	20	7	23
Web 2.0 (AJAX, Wikis, Social Networks)	29	29	12	3	27
CRM (Customer Relationship Management)	33	27	12	1	27
Cloud Computing & Virtualization	44	17	8	1	29
Business Intelligence (Business Analytics, DWH)	40	19	12	1	28
AIM - BPM (Business Process Management), BPEL	41	15	16	0	28
Enterprise Content Management	31	27	8	3	31
Infrastructure Monitoring (Tivoli, HP)	35	17	15	0	33
SOA (Service Oriented Architecture)	37	17	9	2	35
UML (Unified Modelling Language), RUP	32	25	13	1	29
Supply Chain Management	39	17	8	1	35

**Table 11.** Statistic summaries of availability technology skills of fresh graduate

Job Role	Mean	S. Deviation	Median	Skewness	Kurtosis	S. Error
Web 2.0 (AJAX, Wikis, Social Networks)	2.34	0.84	2.28	0.22	-0.56	0.09
CRM (Customer Relationship Management)	2.28	0.90	2.18	0.37	-0.62	0.10
Cloud Computing & Virtualization	2.18	0.88	2.10	0.39	-0.53	0.09
Business Intelligence (Business Analytics, DWH)	1.83	0.89	1.65	0.66	-0.71	0.10
AIM - BPM (Business Process Management), BPEL	2.14	0.96	2.07	0.34	-0.93	0.11
Enterprise Content Management	1.85	0.84	1.76	0.69	-0.30	0.10
Infrastructure Monitoring (Tivoli, HP)	1.74	0.78	1.63	0.65	-0.57	0.09
SOA (Service Oriented Architecture)	1.55	0.81	1.31	1.29	0.73	0.10
UML (Unified Modelling Language), RUP	1.64	0.81	1.40	0.88	-0.45	0.10
Supply Chain Management	1.65	0.82	1.38	0.70	-1.19	0.10
Web 2.0 (AJAX, Wikis, Social Networks)	1.75	0.83	1.63	0.93	0.24	0.10
CRM (Customer Relationship Management)	1.70	0.82	1.46	0.58	-1.28	0.10
Cloud Computing & Virtualization	1.63	0.84	1.38	1.07	0.12	0.10
Business Intelligence (Business Analytics, DWH)	1.76	0.80	1.64	0.61	-0.72	0.10
AIM - BPM (Business Process Management), BPEL	1.55	0.77	1.33	1.13	0.27	0.10

Management. The latter rank is *Business Process Management*. The highest ratio in terms of availability of sufficient trained graduates was for *Database Systems*. **Tables 10** and **11** summarize the overall results.

### Availability of Technology Skills of Existing Staff

To assess the availability of technological skills of existing employees, companies were asked to rank the availability of technological skills of their existing employees using a four-tier rating scale (from no available to too many). Unfortunately, most companies indicated that there were no trained staff available for most of the technologies skills. *Database Systems* gained the highest ranking in terms of too many available trained staff. The second is *Enterprise Development*. The third is *Web Development*. The fourth is for *Network Security* and *Enterprise Resource Planning*. The last is *Service-Oriented Architecture*.



**Table 12.** Availability technology skills of existing employees

Technology Skill	No available trained workforce (1)	Few available trained workforce (2)	Enough available trained workforce (3)	Too much available trained workforce (4)	No Answer
Data Base Systems (Oracle, MS SQL, DB2)	5	19	43	23	10
Enterprise Development (J2EE, .Net, VB, C++)	16	20	27	19	18
Web Development (Java, Apache, PHP, ASP.Net)	23	21	25	18	13
ERP (Enterprise Resource Planning)	23	16	24	15	22
Network Security and Infrastructure (Cisco, IBM)	23	17	23	15	22
Web 2.0 (AJAX, Wikis, Social Networks)	31	16	17	12	24
CRM (Customer Relationship Management)	23	24	21	7	25
Cloud Computing & Virtualization	35	16	15	5	29
Business Intelligence (Business Analytics, DWH)	19	31	15	9	26
AIM - BPM (Business Process Management), BPEL	25	23	17	7	28
Enterprise Content Management	31	16	15	8	30
Infrastructure Monitoring (Tivoli, HP)	31	13	16	7	33
SOA (Service Oriented Architecture)	32	16	17	3	32
UML (Unified Modelling Language), RUP	32	21	12	7	28
Supply Chain Management	35	19	12	4	30

**Table 13.** Statistic summaries of availability technology skills of existing employees

Job Role	Mean	S. Deviation	Median	Skewness	Kurtosis	S. Error
Web 2.0 (AJAX, Wikis, Social Networks)	2.93	0.83	2.99	-0.46	-0.35	0.09
CRM (Customer Relationship Management)	2.60	1.05	2.69	-0.16	-1.20	0.12
Cloud Computing & Virtualization	2.44	1.10	2.48	0.03	-1.34	0.12
Business Intelligence (Business Analytics, DWH)	2.40	1.11	2.50	0.03	-1.39	0.13
AIM - BPM (Business Process Management), BPEL	2.38	1.11	2.44	0.06	-1.38	0.13
Enterprise Content Management	2.13	1.12	1.94	0.41	-1.29	0.13
Infrastructure Monitoring (Tivoli, HP)	2.16	0.97	2.10	0.29	-1.03	0.11
SOA (Service Oriented Architecture)	1.86	0.99	1.53	0.71	-0.81	0.12
UML (Unified Modelling Language), RUP	2.19	0.96	2.08	0.45	-0.76	0.11
Supply Chain Management	2.08	0.99	1.98	0.44	-0.96	0.12
Web 2.0 (AJAX, Wikis, Social Networks)	2.00	1.06	1.75	0.57	-1.05	0.13
CRM (Customer Relationship Management)	1.99	1.07	1.69	0.55	-1.13	0.13
Cloud Computing & Virtualization	1.87	0.94	1.63	0.57	-1.00	0.11
Business Intelligence (Business Analytics, DWH)	1.92	1.00	1.69	0.74	-0.66	0.12
AIM - BPM (Business Process Management), BPEL	1.79	0.93	1.50	0.85	-0.42	0.11

Regarding the availability of trained staff on specific technologies, *Database Systems* is the technology that has the highest proportion of adequately trained staff. *Enterprise Development* comes second. The third is *Web Development* followed by *Enterprise Resource Planning* and *Network Security*. The latter is *Supply Chain Management*. The technology that has a few trained staff is *Business Intelligence*. **Tables 12** and **13** summarize all obtained results.

## RECOMMENDATIONS

Based on the findings of this study, the following are recommendations for different stakeholders:

### Government and Policy Makers

- Strengthening the role of government as a vital player in empowering partnerships among industry, private sector, and academic and research centers. The government should enforce the integration of innovation approaches within educational institutions.

- Promote, improve, and evaluate existing tools and studies used to get the right balance between labor demand and supply. A periodic assessment is needed to forecast the future market demand and then to align the strategic plans of the solicitous parties appropriately.
- Implement a tracking system with the help of the Civil Service Bureau to identify career paths in the ICT sector and plan future academic programs appropriately.
- Develop appropriate policies and programs in order to enhance the female participation in the ICT labor force.
- Support ICT companies financially to encourage them develop training plans for new graduates.

### **The Private Sector**

- Make professional visits to academic institutions, get together with instructors and students and provide time to present technical and awareness sessions.
- Encourage professional staff to acquire and work within the concept of teamwork.
- Pay further attention to the most important professional jobs now and in the future, continual review for jobs that are not important either now or in the future. Also, further attention is required for the jobs that are expected to be of importance in the future to ensure that they are aligned with the strategic plans of the academic community.
- Secure annual financial budget for collaboration with academic and research centers and provide education institutions with the confidence to invest. This budget can be used to sponsor graduation projects, support curriculum development, fund research proposals.
- Develop and share strategic plans with other stakeholders to ensure homogeneity with their policies, and ensure that new graduates will meet labor market needs.
- Come up with appropriate practices to match labor market needs and job requirements with the existing level of skills.

### **Universities & Academic Institutes**

- Plan to develop and build a dynamic high level quality and relevant, industry oriented ICT education through cooperation with all partnerships.
- Develop and maintain dynamic educational programs driven by dynamic curriculum and instructional practices to provide the graduates with pertinent knowledge and skills.
- Support research and development at academic and research centers and align it to labor market needs of technology skills.
- Develop and apply proper approaches to improve the quality of education and training of private university graduates to compete with graduates of public universities in the labor market.
- Provide students with business and soft skills and offer related capacity building and training development programs.
- Strongly considering teaching Business English course as an elective and gradually substitute it with the basic English course.
- Focus on helping students acquire teamwork skills (negotiation, collaboration, and cooperation) by encouraging them to work on course-based projects.

### **All Stakeholders**

- Develop, improve, and expand internship opportunities with industry to align learning outcomes with the current and practical technology skills needed by labor market.
- Encourage the knowledge transfer by promoting the transfer of people and their skills among academic institutions, government, and industry.
- Establish solid bridges and cooperation between partnerships to study the labor market needs of technologies, to facilitate the use of newly innovated technologies, and to provide professionals and experts for the most important ones.

- Honor and place emphasis on academic success stories. Great strides have been made towards curriculum development by many academic institutions and their accomplishments can serve as a role model for others.
- Disseminate and give emphasis to success achievements and cooperation between academia, the industry, and the government.
- Establish communication links between all partnerships and be open to new ideas from all sides.

## CONCLUSION

The service sector is the topmost growing share of the developed economies. The dependency of this sector on information technology (IT) deserves curricula revision of most IT related academic programs. As the discipline of computing endures to expand and diversify, and new computing-related academic programs arise, existing curriculum of academic programs must be updated regularly and new computing disciplines will be originated. This has made the need to develop an interdisciplinary curriculum to prepare university graduates entering the workforce with depth and breadth of skills needed for service sector industries a necessary issue.

The development of curricular guidelines for SSME is particularly challenging. The growing diversity of topics in SSME and the increasing integration of computing with other disciplines (e.g., computer science (Thompson, Bellanca, Owens, & Lorenzo, 2012), business (Conger, 2009), and engineering (Rozenes & Kukliansky, 2014)) create additional challenges. As a result, there is a need to establish international curricular guidelines for a new Bachelor's degree in SSME that will match the latest developments in the discipline and have lasting impact.

In this paper, we have presented and briefly discussed a feasibility study as a basis for establishing an undergraduate program that offers a Bachelor's degree in SSME. First, we identified the body of knowledge areas and skills needed by SSME graduates to compete in the knowledge-based service economy. Secondly, we presented justifications for establishing the new undergraduate SSME program. Finally, we provided the resources considered necessary for establishing SSME department. The establishment of this emerging degree program allows JUST, firstly, to cross the boundaries of traditional IT curricula and respond to an industry need that traditional IT disciplines do not serve, and secondly, to take a unique and pioneering step in this field and thus being the first university in Jordan and in the Middle East in offering this program.

## REFERENCES

- Al-Badarneh, A., Spohrer, J., & Al-Duwairi, B. (2013). A model curriculum for undergraduate program in IT SSME. *International Journal of Service Science, Management, Engineering, and Technology*, 4, 1-18. <https://doi.org/10.4018/ijssmet.2013100101>
- Beblavý, M., Fabo, B., & Lenearts, K. (2016, December). Demand for Digital Skills in the US Labour Market: The IT Skills Pyramid. *Centre for European Policy Studies (CEPS) Catalogue, Special Report No. 154*.
- Bureau of Labor Statistics. (2016, December). *The Employment Situation (USD17-0004)*. Washington, DC: US Department of Labor. Retrieved on January 6, 2017 from [https://www.bls.gov/news.release/archives/empsit\\_01062017.pdf](https://www.bls.gov/news.release/archives/empsit_01062017.pdf)
- Chesbrough, H. (2004, September 24). A failing grade for innovation academy. *Financial Times*. Retrieved on August 1, 2016 from <http://www.ft.com>
- Conger, S. (2009). Information technology service management and opportunities for information systems curricula. *International Journal of Information Systems in the Service Sector*, 1, 58-68. <https://doi.org/10.4018/jisss.2009040104>
- Daniels, P. W. (2012). Service industries at a crossroads: some fragile assumptions and future challenges. *The Service Industries Journal*, 32, 619-639. <https://doi.org/10.1080/02642069.2011.596536>
- Fitzsimmons, J. A., Fitzsimmons, M. J., & Bordoloi, S. (2014). *Service Management: Operations, Strategy, Information Technology* (8<sup>th</sup> ed.). Boston, MA: Mc Graw Hill.
- Hefley, B., & Murphy, W. (Eds.) (2008). *Service Science, Management and Engineering: Education for the 21st Century Series*. New York, NY: Springer. <https://doi.org/10.1007/978-0-387-76578-5>
- Ministry of Information and Communications Technology. (2010). Workforce in Jordanian ICT Industry: Evaluation and Needs Assessment 2010. Jordan: MoICT. Retrieved on January 7, 2015 from <http://moict.gov.jo/uploads/Policies-and-Strategies-Directorate/Surveys/Workforce-in-Jordanian-ICT-Industries/Evaluation-and-Needs-Assessment-of-Workforce-in-Jordanian-ICT-Industries-2010.pdf>
- Ministry of Information and Communications Technology. (2013). Jordan National Information and Communications Technology Strategy (2013-2017). Jordan: MoICT. Retrieved on March 23, 2015 from

<http://moict.gov.jo/uploads/Policies-and-Strategies-Directorate/Strategies/Jordan-National-Information-and-Communications-Technology-Strategy-2013-2017.pdf>

- Ministry of Information and Communications Technology. (2016). ICT and ITES Industry Statistics and Yearbook. Jordan: MoICT. Retrieved on April 2, 2016 from <http://moict.gov.jo/uploads/Policies-and-Strategies-Directorate/Surveys/Industries/ICTandITES-Industry-StatisticsandYearbook-2016.pdf>
- Ministry of Information and Communications Technology. (2016). Jordan National Information and Communications Technology Strategy (2013-2017). Jordan: MoICT. Retrieved on April 23, 2017 from <http://moict.gov.jo/uploads/Policies-and-Strategies-Directorate/Strategies/Jordan-National-Information-and-Communications-Technology-Strategy-2013-2017.pdf>
- Rozenes, S., & Kukliansky, I. (2014). An innovative design approach to new service development learning processes. *International Journal of Information Systems in the Service Sector*, 6, 27-39. <https://doi.org/10.4018/ijss.2014100102>
- Solnet, D. (2012). Service management in hospitality education: Review and reflection. *Journal of Hospitality Marketing & Management*, 21, 184-214. <https://doi.org/10.1080/19368623.2011.584267>
- Soubbotina, T. P., & Sheram, K. A. (2000). Beyond Economic Growth: Meeting the Challenges of Global Development. *WBI Learning Resources*. Washington, DC: World Bank. © World Bank. <https://openknowledge.worldbank.org/handle/10986/15789> License: CC BY 3.0 IGO.
- Spohrer, J., & Kwan, S. K. (2009). Service science, management, engineering, and design (SSMED): An emerging discipline - outline & references. *International Journal of Information Systems in the Service Sector*, 1, 1-31. <https://doi.org/10.4018/ijss.2009070101>
- Spohrer, J., & Maglio, P. P. (2008). The emergence of service science: Toward systematic service innovations to accelerate co-creation of value. *Production and Operation Management*, 17, 1-9. <https://doi.org/10.3401/poms.1080.0027>
- Spohrer, J., & Maglio, P. P. (2010). Toward a Science of Service Systems. In Maglio, P., Kieliszewski, C., Spohrer, J. (eds), *Handbook of Service Science. Service Science: Research and Innovations in the Service Economy* (pp. 157-194). Springer, Boston, MA. [https://doi.org/10.1007/978-1-4419-1628-0\\_9](https://doi.org/10.1007/978-1-4419-1628-0_9)
- Spohrer, J., Maglio, P. P., Bailey, J., & Gruhl, D. (2007). Steps toward a science of service systems. *Computer*, 40, 71-77. <https://doi.org/10.1109/MC.2007.33>
- Teboul, J. (2006). *Service Is Front Stage: Positioning Services for Value Advantage*. Hampshire, England: Palgrave Macmillan. <https://doi.org/10.1057/9780230579477>
- Thompson, J., Bellanca, M., Owens, N., & Lorenzo, G. (2012). Essential computer skills for college students. *International Journal of Information Systems in the Service Sector*, 4, 53-66. <https://doi.org/10.4018/ijss.2012010104>
- Witell, L., Snyder, H., Gustafsson, A., Fombelle, P., & Kristensson, P. (2016). Defining service innovation: A review and synthesis, *Journal of Business Research*, 69, 2863-2872. <https://doi.org/10.1016/j.jbusres.2015.12.055>

<http://www.ejmste.com>

# Influence of Instructional Design to Manage Intrinsic Cognitive Load on Learning Effectiveness

Yi-Hung Huang <sup>1\*</sup>

<sup>1</sup> National Taichung University of Education, Taichung, TAIWAN

Received 7 April 2017 • Revised 24 January 2018 • Accepted 13 March 2018

## ABSTRACT

For elementary school students who are accustomed to solving single-layer mathematical problems, integrating multiple mathematical concepts and applying them to seek solutions is clearly a complex task. From the perspective of cognitive load, students may often find their intrinsic cognitive load exceeding their processing capacity when they face such tasks. This study investigated two strategies to manage intrinsic cognitive load: pretraining and segmented learning. The researcher first employed cognitive load theory to analyze the cognitive load faced by students using the two types of materials and then performed an experiment to verify theoretical analysis. At the same time, the researcher used the multidimensional cognitive load scale to gauge the cognitive loads perceived by the students. Experiment results showed that multidimensional cognitive load scale successfully measured the intrinsic load and extraneous load perceived by the students and pretraining resulted in lower perceived cognitive load than segmented learning. They further indicated that interaction effects exist between the two strategy groups and the high and low prior knowledge groups in posttest scores. This study suggests that pretraining is probably a more suitable instructional strategy to manage intrinsic load for most older elementary school students.

**Keywords:** cognitive load theory, intrinsic cognitive load, instructional design, mathematics education

## INTRODUCTION

A comprehensive review of sixth-grade mathematics textbooks show that most units require the students to integrate the basic mathematics skills that they have acquired from first grade to fifth grade to solve problems in everyday life. Examples of these units include "How to Solve It" and "Reference Quantities and Comparison Quantities" (Huang, 2012). For elementary school students that are accustomed to solving problems using a single skill or concept, integrating multiple mathematical concepts and problem-solving procedures and then applying them is clearly a complex learning task. Indeed, students often find their intrinsic cognitive load exceeds their processing capacity when they face such tasks. Thus, the means of planning lessons appropriately to control intrinsic load during the instructional process and successfully achieve instructional objectives is crucial for sixth-grade mathematics teachers.

Cognitive load theory (CLT) posits that controlling intrinsic load depends on two aspects (Sweller, Ayres, & Kalyuga, 2011). The first aspect, referred to as pretraining, targets the student's personal capabilities, wherein the basic schemata necessary to complete a new task is presented before combining multiple lower-level interactive elements into a single higher-level interactive element for processing. In this manner, intrinsic load associated with the learning process can be effectively reduced. Exemplar strategies of this approach include the pretraining principle presented by Mayer and Moreno (2010), the isolated elements effect proposed by Sweller et al. (2011), and the part-whole approach proposed by Kester, Paas, and van Merriënboer (2010). The second aspect, referred to as segmenting, targets the task itself; i.e., the order in which the task is presented. At first students are asked to process

#### **Contribution of this paper to the literature**

- The researcher designed systematically two sets of materials to manage intrinsic cognitive load to provide elementary school teachers with useful reference.
- The researcher compared representative instructional strategies in the two different aspects (pretraining and segmenting), with regard to their influence on perceived cognitive load and learning effectiveness.
- The researcher referred to the multidimensional cognitive load scale and successfully measured the intrinsic load and extraneous load perceived by the students.

subtasks with a smaller number of elements before the number of elements and the interactivity of the task are gradually increased. Instructional strategies in this aspect include the segmenting principle proposed by Mayer and Moreno (2010), and the whole-part approach presented by Kester et al. (2010).

The studies above demonstrate that instructional strategies can effectively manage intrinsic load and thereby enhance the learning effectiveness of students. However, no study has compared the instructional strategies of these two aspects. The purpose of this study was therefore to compare representative instructional strategies in the two different aspects (pretraining and segmenting), with regard to their influence on perceived cognitive load and learning effectiveness.

This study used the "Reference Quantities and Comparison Quantities" unit in sixth-grade mathematics curriculum in Taiwan to compare two strategies for intrinsic cognitive load management: pretraining and segmenting. First, the researcher designed two sets of learning materials based on the two instructional strategies and then employed CLT to analyze the cognitive load engendered by these materials. An experiment was then performed to examine the influence of the two instructional strategies on the learning effectiveness and cognitive loads of students with different levels of prior knowledge. In addition, the researcher used the multidimensional cognitive load scale developed by Leppink, Paas, van der Vleuten, Van Gog, and Van Merriënboer (2013) to gauge the cognitive load perceived by the students, assess the effectiveness of the multidimensional indicator, and thereby verify the results of theoretical analysis.

## **LITERATURE REVIEW**

### **Cognitive Load Theory**

CLT was proposed by Australian scholar Sweller (1988) to examine the influence of instructional design and learning content on learning and cognition. The structure of human cognition includes working memory, which processes conscious activities with a limited capacity, and long-term memory, which stores schema structures at different levels of automation with unlimited capacity. When the amount of information that an individual is processing exceeds the capacity or temporal limits of his or her working memory, it creates a cognitive load that interferes with the individual's cognitive process, which hinders learning.

In Sweller's (2010a) later revisions of the theory, he simplified the various sources of cognitive load into one, namely, element interactivity, and revised the types of cognitive load that an individual may perceive to include only intrinsic and extraneous cognitive load. This revised perspective enhanced the integrity of CLT. Intrinsic cognitive load is determined by the complexity of the learning material. The degree of intrinsic cognitive load depends on the interaction of the learner with the learning material. Extraneous cognitive load refers to the number of interactive elements included in the learning material or teaching process. Thus, from the perspective of CLT, the objective of instructional design is to reduce extraneous cognitive load, optimize intrinsic load, ensure that the sum of intrinsic load and extraneous load does not exceed the cognitive capacity and limits of the learners, and increase the use of germane resources as much as possible (Ayres, 2013; Kalyuga, 2015; Leppink & van den Heuvel, 2015).

### **Intrinsic Load Management**

Numerous instructional strategies have been developed in recent years to reduce extraneous load (Sweller, 2010a). However, how should educators proceed when the extraneous load has been eliminated as much as possible, but the intrinsic load still exceeds the learner's cognitive capacity?

Intrinsic cognitive load is determined by the complexity of the learning task. It can only be reduced by expanding the knowledge of the learner or altering the nature of the learning task. Therefore, relevant research has tackled this issue from one of two aspects (Sweller et al., 2011). The first aspect starts from the learner's own capabilities by first constructing the basic schemata needed to complete the new tasks and then combining multiple lower-level interactive elements into a single higher-level interactive element for processing. In this manner, the



intrinsic load during the learning process can be effectively reduced. In accordance with the work of Mayer and Moreno (2010), we call this method ‘pretraining’. This approach is used to develop specific prior knowledge; i.e., prior to the presentation of key materials. Learners initially need only complete a portion of the tasks with lower element interactivity and do not encounter tasks with greater element interactivity until later in the learning phase (Kester et al., 2010). Mayer and Moreno (2003) stated that teaching about the parts of the system before teaching about how the system works enhances learning effectiveness. Kester, Kirschner, and van Merriënboer (2004a, 2004b, 2006) agreed that reducing element interactivity at first helps learners process complex concepts. Research conducted by Pollock, Chandler, and Sweller (2002) and Clarke, Ayres, and Sweller (2005) on mathematics learning tasks revealed that when low-ability learners study from materials with high element interactivity, initially presenting only a small portion of the elements and their interactivity and then gradually including the rest promotes better learning transfer. Ayres (2006a, 2013) established that low-ability learners benefit from reduced element interactivity in the beginning, whereas high-ability learners benefit from high element interactivity early on in the learning process.

The other aspect starts from the task itself. Mayer and Moreno (2010) call this approach ‘segmenting’, in which the number and interactivity of elements are shown to the learners early on in the learning process. However, learners are required to process only subtasks, which include fewer elements. The number of elements and degree of interactivity are gradually increased as the complexity of the tasks executed by students increases (Kester et al., 2010). Creating a learning environment that focuses on subtasks helps to reduce the degree of interactivity among elements, by narrowing the number of elements learners must consider at any given time; i.e., releasing them from the difficulty of considering all of the elements in the task simultaneously. They learn by segmenting (Mayer et al., 2010) or with worked examples and completion tasks (Renkl & Atkinson, 2010). Worked examples attract the learners’ attention to the correct problem-solving process so that they do not need to waste cognitive resources on tasks unrelated to the correct problem-solving steps. In this manner, they reduce the element interactivity required for processing during the learning process. Once the learners have completely understood the worked examples, they can then construct problem-solving schemata by practicing completion tasks. Many studies have used worked examples and completion tasks to enhance the learning effectiveness of low-ability learners.

The studies above demonstrate that the instructional strategies of these two aspects can manage intrinsic load to some degree and thereby enhance learning effectiveness. However, no study has compared the instructional strategies of these two aspects. This study therefore compared representative instructional strategies in the two different aspects with regard to their influence on perceived cognitive load and learning effectiveness.

## Measurement of Cognitive Load

Based on the characteristics of extraneous and intrinsic load, cognitive load is a multidimensional indicator. It can be perceived by learners, and it is a quantity that may fluctuate during the learning process. Despite the many research appeals to measure cognitive load (Ayres, 2006b; DeLeeuw & Mayer, 2008; Galy, Cariou, & Mélan, 2012), it remains unclear how best to quantify the different types of cognitive load adopting multiple items to gauge various types of cognitive load can provide more accurate measurements than using a single item and distinguish different types of cognitive load more clearly (Leppink, Paas, van der Vleuten, Van Gog, & Van Merriënboer, 2014). As a result, Leppink et al. (2014) and Leppink and van den Heuvel (2015) suggested using six questions to gauge the intrinsic and extraneous load that learners perceive. Germane cognitive load, however, can only be indirectly verified via learning effectiveness. In consideration of factors such as location and method of implementation, the researcher adopted the aforementioned tool to measure the intrinsic and extraneous load that learners perceive and regarded learning effectiveness as an auxiliary objective reference value.

Based on CLT and the analysis of relevant literature, the questions that this study sought to answer are as follows:

1. Do students with different levels of prior knowledge perceive significantly different levels of intrinsic and extraneous load when reading two different learning materials that control intrinsic load?
2. Do students with different levels of prior knowledge display significant differences in learning effectiveness when reading two different learning materials that control intrinsic load?

## METHODOLOGY

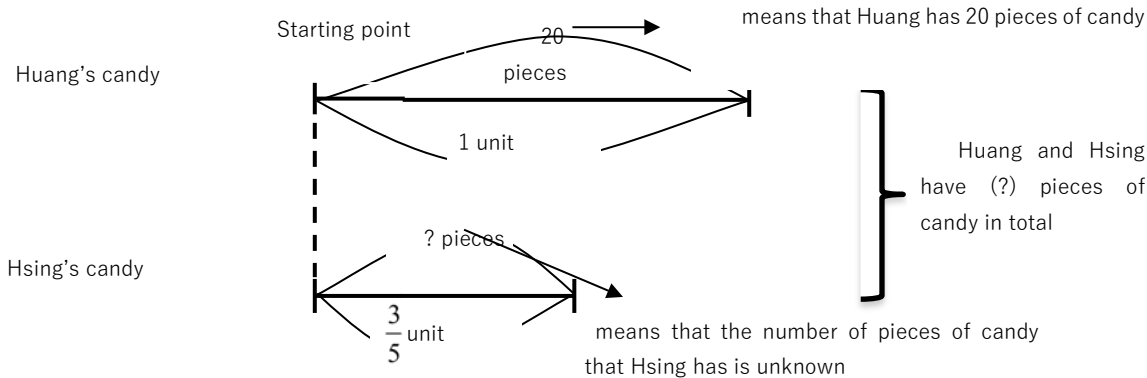
### Segmenting and Pretraining Learning Materials

Previous researchers (Lee, 2013; Huang & Shie, 2016) have reported that the “Reference Quantities and Comparison Quantities” unit in sixth-grade mathematics texts in Taiwan imposes high cognitive load. This can be attributed to the fact that the students must be able to identify the reference quantity as well as the comparison

1. Huang has 20 pieces of candy. Hsing has  $\frac{3}{5}$  the candy Huang has. How many pieces of candy do Huang and Hsing have altogether?

**Step 1: Express the relationship between the quantities of candy that Huang and Hsing have using a line segment diagram.**

As Hsing has  $\frac{3}{5}$  the candy Huang has, the candy that Huang has serves as the reference quantity. Draw as a line segment diagram, Huang's quantity of candy has can be drawn as a line that is 1 unit in length, while the number of pieces of candy that Hsing has can be drawn as a line that is  $\frac{3}{5}$  of the length of the line representing the number of pieces of candy that Huang has.



**Step 2: Find the solution to the problem based on the line segment diagram.**

The diagram above shows that Huang has 20 pieces of candy, whereas Hsing has an unknown quantity of candy. If the number of pieces of candy that Huang has is considered as a single unit, then the number of pieces of candy that Hsing has is  $\frac{3}{5}$  of that unit.

Thus, Huang and Hsing have a total of  $(1 + \frac{3}{5})$  units of candy.

Therefore, the number of pieces of candy that Huang and Hsing have in total is

$$20 \times (1 + \frac{3}{5}) = 20 \times \frac{8}{5} = 32.$$

Ans: 32 pieces of candy in total

**Figure 1.** Worked example for segmented learning

quantity and adopt different problem-solving methods to solve the problems. The researcher therefore used this unit as the learning topic of the experiment in this study.

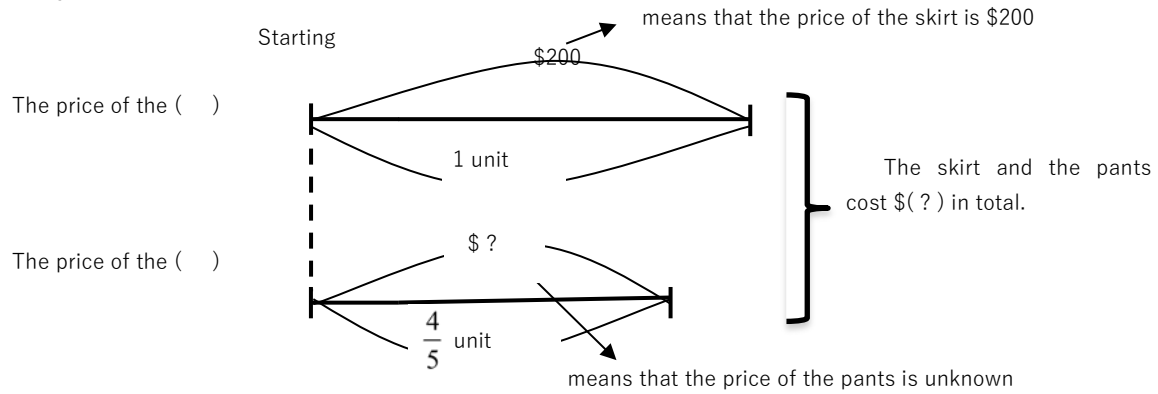
First, we present an example of segmented learning (Figure 1). The complete problem is shown at the beginning of the lesson. The first step is to explain how reference quantities and comparison quantities are to be identified, and the relationship between the two quantities are drawn in a line segment diagram. The second step is to explain how the clues in the line segment diagram are used to present the relationship in a mathematical expression. The students only need process a single step at a time, which reduces element interactivity and thereby manages intrinsic load.

When students finish reading a worked example, a similar example with less explanation is given in the form of a completion task, as shown in Figure 2. A blank space is left for the students to take notes in order that they may dedicate as much energy as possible to understanding the content, thereby easing germane load (Ayres, 2006a, 2013). The students are given the answer in the text; however, they must read the materials carefully to find it. This helps to ensure that they attend to the connection between  $(1 + \frac{3}{5})$  and the equations, since the key point is to understand the concept on which the solving method is based. This instructional strategy starts from the task itself and arranges the subtasks in an appropriate order, from simpler tasks with lower element interactivity to the complete task with greater complexity and element interactivity.

2. The teacher goes to the department store to buy a skirt and a pair of pants. The skirt is \$200, and the price of the pants is  $\frac{4}{5}$  that of the skirt. How much did the teacher spend on her new clothes?

**Step 1: Express the relationship between the prices of the skirt and the pants using a line segment diagram.**

As the price of the pants is  $\frac{4}{5}$  that of the skirt, the price of the pants serves as the reference quantity. Drawn as a line segment diagram, the price of the skirt can be drawn as a line that is 1 unit in length, while the price of the pants can be drawn as a line that is  $\frac{4}{5}$  of the length of the line representing the price of the skirt.



**Step 2: Find the solution to the problem based on the line segment diagram.**

The diagram above shows that the skirt is \$200, whereas the price of the pants is unknown. If the price of the skirt is considered 1 unit, then the price of the pants is  $\frac{4}{5}$  unit.

Thus, the skirt and the pants cost ( ) units in total.

Therefore, the total cost of the skirt and the pants is  $200 \times \left(1 + \frac{4}{5}\right) = 200 \times \frac{9}{5} = 360$

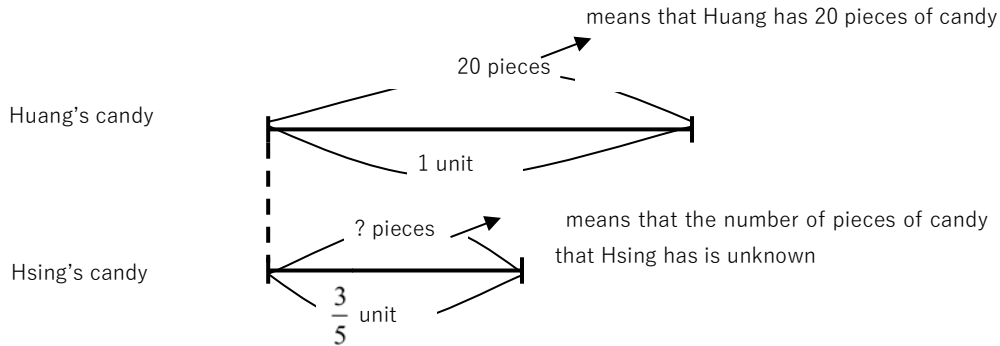
Ans: They cost \$360 in total

**Figure 2.** Completion task for segmented learning

Next, we present the learning materials for the pretraining group. The example for this group is composed of two parts. The first part involves training the learners in the basic concepts needed to solve problems with reference quantities and comparison quantities, including identifying the reference quantity and drawing the line segment diagram. As with the segmented learning group, the students are given a similar problem to practice on after they have read a worked example, as shown in [Figure 3](#).

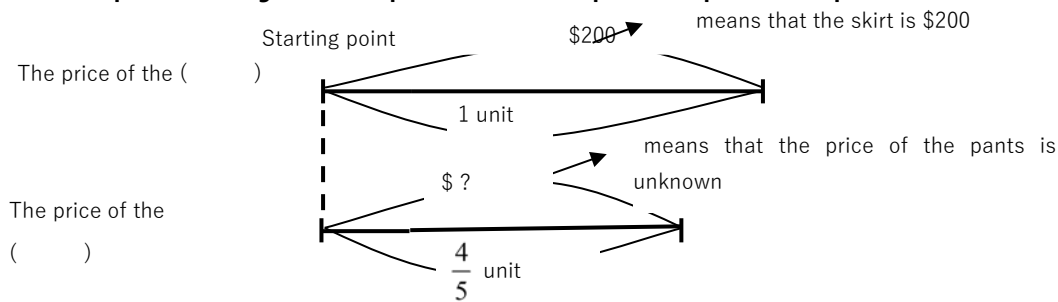
**Training 1-1.** Hsing has  $\frac{3}{5}$  the candy that Huang has, which means that the quantity of candy that Huang has serves as the reference quantity. In a line segment diagram, the number of pieces of candy that Huang has can be drawn as a line that is 1 unit in length, while the number of pieces of candy that Hsing has can be drawn as a line that is  $\frac{3}{5}$  of the length of the line representing Huang's candy.

**Task:** Use two parallel line segments to express the relationship between the candy that Huang and Hsing have.



**Training 1-2.** The price of the pants is  $\frac{4}{5}$  times that of the skirt. This means that the price of the pants serves as the reference quantity. In a line segment diagram, the price of the skirt can be drawn as a line that is 1 unit in length, while the price of the pants can be drawn as a line that is  $\frac{4}{5}$  of the length of the line representing the price of the skirt.

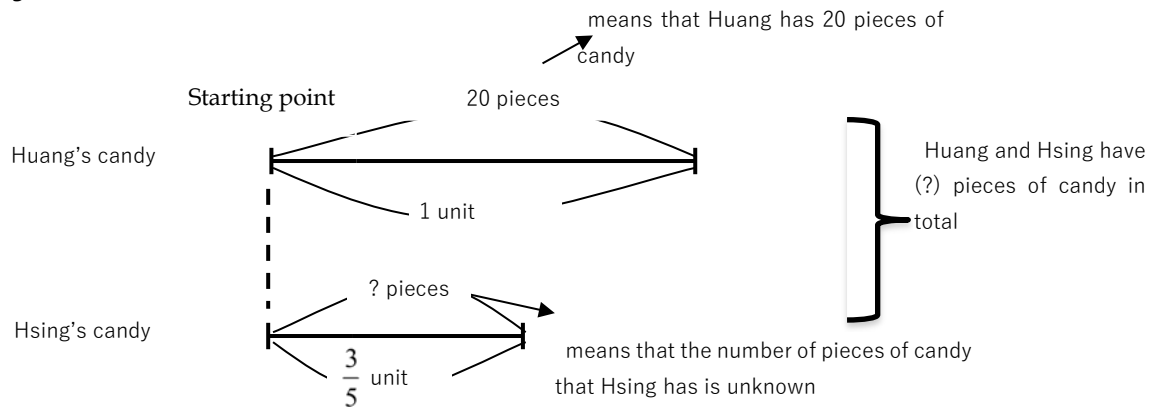
**Task:** Use two parallel line segments to express the relationship between prices of the pants and the skirt.



**Figure 3.** Worked example and complete task for drawing the line segment diagram

Next we present an explanation of how to translate the information held in a line segment diagram into a mathematical expression. This is followed by a similar problem on which students may practice. The materials are as shown in [Figure 4](#) and [Figure 5](#).

**Training 2-1.** Use the line segments in the diagram below to find how many pieces of candy Huang and Hsing have altogether.



**Task:** Find the solution to the problem based on the line segment diagram.

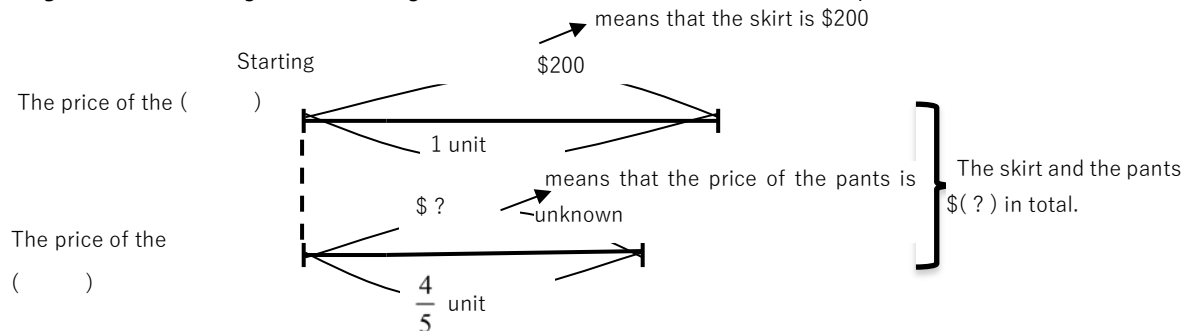
The diagram above shows that Huang has 20 pieces of candy, whereas Hsing has an unknown number of pieces of candy. If the number of pieces of candy that Huang has is considered 1 unit, then the number of pieces of candy that Hsing has is  $\frac{3}{5}$  of a unit. Thus, Huang and Hsing have a total of  $(1 + \frac{3}{5})$  units of candy.

Therefore, the number of pieces of candy that Huang and Hsing have in total is

$$20 \times \left(1 + \frac{3}{5}\right) = 20 \times \frac{8}{5} = 32 \qquad \text{Ans: 32 pieces of candy in total}$$

**Figure 4.** Worked example for operating the line segment diagram

**Training 2-2.** Use the line segments in the diagram below to find how much the skirt and the pants cost in total.



**Task:** Find the solution to the problem based on the line segment diagram.

The diagram above shows that the skirt is \$200, and the price of the pants is unknown. If the price of the skirt is considered 1 unit, then the price of the pants is  $\frac{4}{5}$  of a unit. Thus, the skirt and the pants cost ( ) units in total.

$$\text{Therefore, the total cost of the skirt and the pants is } 200 \times \left(1 + \frac{4}{5}\right) = 200 \times \frac{9}{5} = 360$$

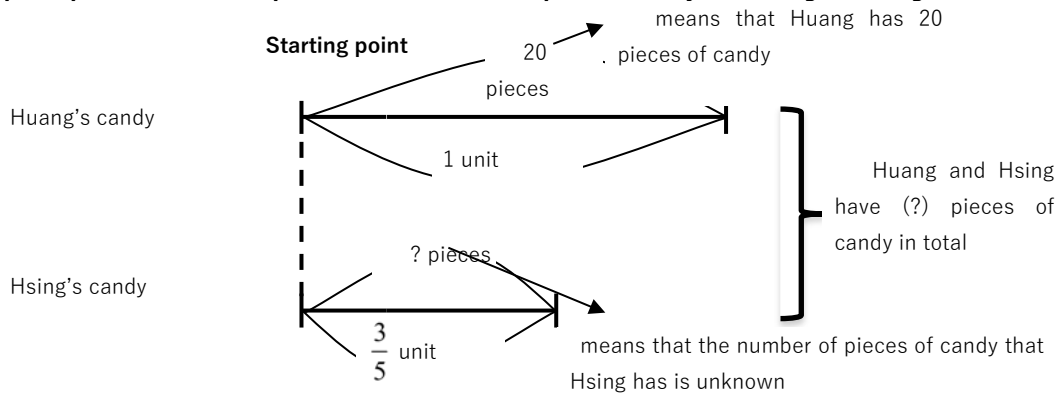
Ans: They cost \$360 in total

**Figure 5.** Completion task for operating the line segment diagram

The students do not learn how to solve a complete problem with reference quantities and comparison quantities until the second part. When the students finish reading a worked example, a similar completion task is provided for the students to practice on, as shown in **Figure 6** and **Figure 7**. In the first part, they learn how to draw a line segment diagram to express the relationship between two objects and how to interpret the information held in a line segment diagram. Unlike the worked example for the segmented learning group, the two steps do not offer any instructional explanations; they merely present the line segment diagram representation and the mathematical expression.

1. Huang has 20 pieces of candy. Hsing has  $\frac{3}{5}$  the candy Huang has. How many pieces of candy do Huang and Hsing have altogether?

**Step 1: Express the relationship between the numbers of pieces of candy that Huang and Hsing have:**



**Step 2: Find the solution to the problem based on the line segment diagram.**

The number of pieces of candy that Huang and Hsing have in total is

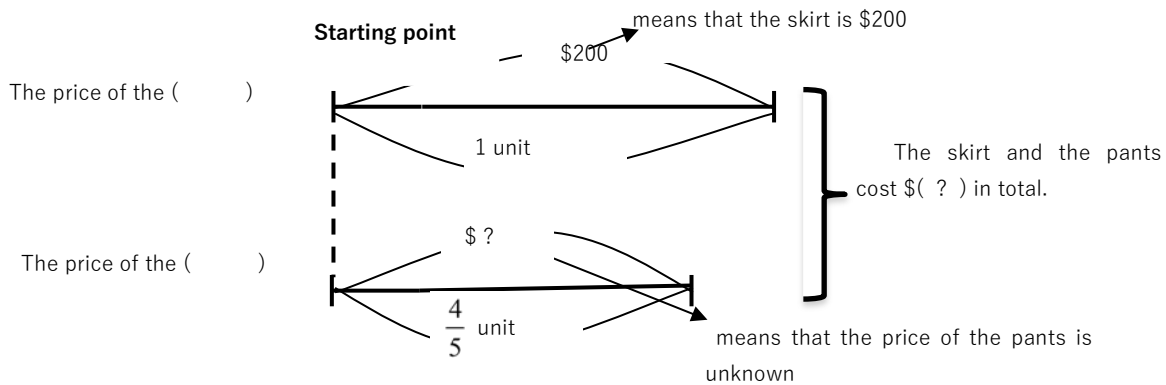
$$20 \times \left(1 + \frac{3}{5}\right) = 20 \times \frac{8}{5} = 32$$

Ans: 32 pieces of candy in total

Figure 6. Worked example for pretraining group

2. The teacher goes to the department store to buy a skirt and a pair of pants. The skirt is \$200, and the price of the pants is  $\frac{4}{5}$  that of the skirt. How much did the teacher spend on her new clothes?

**Step 1: Express the relationship between the prices of the skirt and the pants using a line segment diagram.**



**Step 2: Find the solution to the problem based on the line segment diagram.**

Therefore, the total cost of the skirt and the pants is  $200 \times \left(1 + \frac{4}{5}\right) = 200 \times \frac{9}{5} = 360$

Ans: They cost \$360 in total

Figure 7. Completion task for pretraining group

The design principle of these learning materials is to first construct the basic schemata that the students need to complete the new task, namely, drawing the relationship between two objects using a line segment diagram and interpreting the line segment diagram representation. Once these basic schemata have been established, the students then learn how to use these two schemata to solve reference quantities and comparison quantities problems via the worked example. When students construct basic schemata, multiple interactive elements are merged into a single interactive element in process, which effectively reduces the intrinsic load during the learning process.



## Research Hypotheses

Existing research (Ayres, 2006a, 2013; Huang & Shie, 2016) indicates that the prior knowledge influences a student's cognitive load and learning effectiveness. In view of this, the researcher investigated the cognitive load that learners with high and low prior knowledge may face during the learning process. Learners with high prior knowledge that can understand the concepts explained in Steps 1 and 2 in the example in **Figure 1** need only focus on how to integrate the concepts to solve the problem. Segmented learning awakens their prior knowledge and assists the learner in constructing new problem-solving schemata. For learners with low prior knowledge, who are not as familiar with the relevant knowledge, pretraining enables learners to first construct the schemata of sub-concepts, which contain fewer interactive elements and thus result in lower intrinsic load. Once they are familiar with the sub-concepts, the interactivity of the elements can be increased so that the learners can construct the complete problem-solving schemata, which reduces their cognitive load.

Based on existing research (Ayres, 2006a, 2013) and the analysis above, the researcher inferred that segmented learning creates greater cognitive load than pretraining. Furthermore, prior knowledge interacts with the selected learning strategy. In other words, segmented learning is more effective than pretraining for students in the high prior knowledge group, whereas pretraining should be more effective than segmented learning for students in the low prior knowledge group. This difference is the result of the prior knowledge of the students.

## Participants

The participants in the experiment of this study comprised 105 sixth-graders from four classes in an elementary school in Central Taiwan. The experiment was conducted one week after their midterms during the first semester. The curriculum used for the experiment was Unit 3 of Book 12 of the mathematics textbooks published by Nan-i Publishing Co. (Huang, 2012), which the students would have learned during the second semester. This prevented the possibility that students would have already come across the target content. To determine the influence of the two types of strategies on students with different levels of prior knowledge, we used the median of the students' midterm exam scores to divide the students into a high prior knowledge group and a low prior knowledge group. The students in these two groups were then randomly assigned to the segmented learning group and the pretraining group. The learning effectiveness and perceived cognitive load of the two groups were then compared. Using midterm scores to group the students had two merits. One is that the scope of the midterm exam covered division with fractions and ratios, which constitute the necessary prior knowledge for the "reference quantities and comparison quantities" unit. The students' midterm scores therefore served as an indicator of prior knowledge. The other merit was that a pretest, which would have affected the results of the posttest, was not needed to group the students.

## Experimental Design

### *Experimental procedure*

This experiment comprised two phases. During the first phase, the students read the materials to learn how to solve problems with reference quantities and comparison quantities. The second phase was the posttest, which assessed differences in learning effectiveness. Neither the pretraining group nor the segmented learning group were taught by a teacher; the learning examples were only presented on paper. The format of the problems and explanations in the examples were the same; i.e., they differed only in their presentation, as described above. This ensured that the students in the two groups experienced the same level of extraneous load but different levels of intrinsic load. During the learning process, the students were asked to fill out a cognitive load questionnaire after each pair of worked examples.

**Phase 1:** The students in the pretraining group first learned how to identify reference quantities and comparison quantities and draw line segment diagrams for the two pairs of corresponding examples. They were given three minutes to learn each pair of examples for a total of learning time of six minutes. Then, the students learned how to write mathematical expressions based on clues in the line segment diagrams. Again, they learned two pairs of corresponding examples. They were given three minutes of learning time for each pair of examples, so the learning time for this part was six minutes in total. Next, they learned how to solve two pairs of worked examples and completion tasks with reference quantities and comparison quantities. The reference quantity was unknown in one pair of problems, while the comparison quantity was unknown in the other pair of problems. They were given four minutes of learning time for each of the four problems, so the learning time for this part was 16 minutes in total. After a worked example and a completion task, the students were asked to fill out a cognitive load questionnaire. Each questionnaire took two minutes, so the two questionnaires took four minutes in total. Thus, the entire learning process for the pretraining group in Phase 1 was 32 minutes.

1. The teacher bought a box of markers and a box of crayons at the stationary store. The box of markers was \$72, and the box of crayons cost  $\frac{3}{4}$  as much as the box of markers. How much did the teacher spend in all?
2. John went to the supermarket to buy some fruit and vegetables. The vegetables cost \$128 in total, and the fruit cost  $\frac{3}{4}$  as much as the vegetables. What was the difference between the cost of the vegetables and the cost of the fruit?
3. Lily planted some red and white roses in the garden. The white roses covered 144 hectares, and the white roses covered  $\frac{3}{4}$  as much area as the red roses. What was the difference between the area of the white roses and the area of the red roses?
4. There are 84 yellow and blue marbles in total. There are  $\frac{3}{4}$  times as many yellow marbles as there are blue marbles. How many yellow marbles are there? How many blue marbles are there?
5. Among the members of the choir this year, the number of girls is  $\frac{2}{5}$  times that of the number of boys. The difference between the number of boys and the number of girls is 96. How many boys are there? How many girls are there?

**Figure 8.** Posttest problems

In the segmented learning group, the students were given the complete problems at the beginning, following which learning tasks were given to teach each portion in segments. The students were given two pairs of worked examples and completion tasks with reference quantities and comparison quantities. The reference quantity was unknown in one pair of problems, while the comparison quantity was unknown in the other pair of problems. They were given seven minutes of learning time for each of the four problems, so the learning time for this part was 28 minutes in total. After a worked example and a completion task, the students were asked to fill out a cognitive load questionnaire. Each questionnaire took two minutes, so the two questionnaires took four minutes in total. Thus, the total learning time for the segmented learning group was also 32 minutes, thereby enabling the students in the two groups to learn under the same conditions.

**Phase 2:** After reading the materials, the two groups of students took a posttest containing five problems to determine the influence of the two different instructional strategies on their learning effectiveness and transfer of learning ability. The first three problems in the posttest involved near transfer of learning, whereas the last two problems involved far transfer of learning. The posttest scores were recorded in points.

The independent variables of this experiment were the prior knowledge of the students and the two different learning strategies, whereas the dependent variables were perceived cognitive load and learning achievement. The control variables were the learning content, the learning location, and paper learning materials.

### *Pretraining materials*

The pretraining materials contained three parts. The first part focused on drawing line segment diagrams and contained two pairs of problems, each pair comprising an example and a problem-solving exercise, as shown in [Figure 3](#). This part aimed to enhance student understanding of how to draw line segment diagrams based on the meaning of the problem. The second part focused on the interpretation of line segment diagrams. Again, this part contained two pairs of problems, each pair comprising an example and a problem-solving exercise, as shown in [Figure 4](#) and [Figure 5](#). This part aimed to enhance student understanding of mathematical expressions based on line segment diagrams. The third part contained the worked example and completion task, as shown in [Figure 6](#) and [Figure 7](#). The practice scores were recorded in points in the third part.

### *Segmented learning materials*

The segmented learning materials display the problem at the beginning and then present the learning tasks of each segment. The learners need only focus on the individual task at hand, thereby reducing intrinsic load. [Figures 1](#) and [2](#) display the examples in the segmented learning materials. The practice scores were recorded in points.

### *Posttest*

The objective of the posttest is to gauge the effectiveness of near and far transfer of learning. The test contained five problems: The first three problems having a similar structure with the problems in the learning materials assessed the near transfer of learning, while the last two problems having a different structure with the problems in the learning materials assessed the far transfer of the students' learning. [Figure 8](#) displays the problems used in the posttest. Each problem counted for two points, one for each of the two steps in the learning example.

### *Cognitive load assessment questionnaire*

The questionnaire was designed as suggested by Leppink and van den Heuvel (2015). However, considering the fact that elementary students may not be able to differentiate between different levels, the researcher simplified

Please answer the six questions below based on your feelings after reading the materials. Please choose one answer for each question.

**Please read each question carefully, think about it, and then write down your answer.**

- ( ) 1. The content of the materials that I just read were (1) not complicated at all (2) a little complicated (3) half complicated (4) mostly complicated (5) completely complicated.
- ( ) 2. The problems in the materials that I just read were (1) not complicated at all (2) a little complicated (3) half complicated (4) mostly complicated (5) all complicated.
- ( ) 3. Of the materials that I just read, (1) nothing was complicated (2) a few parts were complicated (3) half of the parts were complicated (4) most of the parts were complicated (5) all of the parts were complicated.
- ( ) 4. The explanations in the materials that I just read were (1) all very clear (2) a little unclear (3) half clear and half unclear (4) mostly unclear (5) all very unclear.
- ( ) 5. I understood (1) all (2) most (3) half (4) only a little (5) none of the explanations in the materials that I just read.
- ( ) 6. I learned (1) all (2) most (3) half (4) only a little (5) none of the materials that I just read.

**Figure 9.** Cognitive load scale

**Table 1.** Descriptive statistics of learning effectiveness of various groups

Instructional strategy group (Full score)	Pretraining M (SD)		Segmented learning M (SD)		Subtotal M (SD)	
	High	Low	High	Low	High	Low
<b>Prior knowledge group</b>						
Number of students	24	25	26	24	50	49
Posttest score (10)	7.25(2.17)	3.28(1.60)	5.35(2.47)	3.67(2.26)	6.26(2.50)	3.47(1.94)
Subtotal	5.22(2.75)		4.54(2.49)			
<b>Practice score (5)</b>						
Practice score (5)	4.96(.20)	4.92(.27)	4.69(.74)	4.33(.82)	4.82(.56)	4.63(.67)
Subtotal	4.94(.24)		4.52(.79)			
<b>Intrinsic load (5)</b>						
Intrinsic load (5)	1.13(0.22)	1.39(0.82)	1.35(0.49)	1.67(0.65)	1.24(0.39)	1.52(0.75)
Subtotal	1.26(0.61)		1.50(0.59)			
<b>Extraneous load (5)</b>						
Extraneous load (5)	1.19(0.61)	1.37(0.66)	1.16(0.36)	1.59(0.59)	1.17(0.49)	1.48(0.63)
Subtotal	1.28(0.64)		1.37(0.53)			

the nine-point scale to a five-point scale. The questions were as shown in **Figure 9**. The first three questions served as the indicator for intrinsic load, while the last three problems served as the indicator for extraneous load.

### Data analysis

The data analysis in this study was conducted using SPSS for MS Windows 18.0. Using factor analysis, the results of the first three questions in the cognitive load scale were extracted as intrinsic load and the results of the last three questions as extraneous load. With the high and low prior knowledge group and the two different learning groups as the independent variables and the posttest scores and cognitive load indicators as the dependent variables, a two-factor analysis of variance was conducted to determine the influence of the prior knowledge grouping and instructional design grouping on perceived cognitive load and posttest scores.

## RESULTS

### Descriptive Statistics

After eliminating six students with incomplete tests, the researcher analyzed the data from the remaining 99 students, among which 49 were in the pretraining group and 50 were in the segmented learning group. The descriptive statistics of the high and low prior knowledge groups with regard to posttest scores, practice scores, intrinsic load, and extraneous load are presented in **Table 1**.

## Results

### *Cognitive load indicator analysis*

Factor analysis of the intrinsic load confirmed the scale of measurement with an eigenvalue of 2.71, which accounted for 90.33% of the total variance. Factor analysis of the extraneous load confirmed the scale of measurement with an eigenvalue of 2.56, which accounted for 85.38% of the total variance. The internal consistency of our questionnaires was satisfactory for both intrinsic load (Cronbach's alpha = .95) and extraneous load (Cronbach's alpha = .91).

Based on the experiment results, the research performed a two-factor analysis of variance on the measurements of intrinsic load in the two instructional strategy groups and high and low prior knowledge groups. *Levene's* test for homogeneity was first conducted. The intrinsic load result was  $F(3, 95) = 2.549, p = .060$ , which does not reach significance. This indicates homogeneity and that the analysis of variance can be performed. The interaction effects between the two strategy groups and high and low prior knowledge groups resulted in  $F(3, 95) = .077, p = .783$ , which does not reach significance. Thus, no interaction effects existed between the two strategy groups and high and low prior knowledge groups. As the interaction effects were not statistically significant, the main effects of the two strategy groups and high and low prior knowledge groups were examined.

The analysis result for the two strategy groups in intrinsic load was  $F(3, 95) = 4.333, p = .040$ , which reaches the level of significance. Thus, the mean of intrinsic load of the pretraining group, 1.26, is significantly lower than that of the segmented learning group, 1.50. This result verifies the previous inferences in that the pretraining strategy will result in lower perceived cognitive load than the segmented learning strategy. The analysis result for the high and low prior knowledge groups in intrinsic load was  $F(3, 95) = 5.899, p = .017$ , which reaches the level of significance. Thus, the mean of intrinsic load of the high prior knowledge group, 1.24, is significantly lower than that of the low prior knowledge group, 1.52.

A two-factor analysis of variance was then performed on the measurements of extraneous load in the two instructional strategy groups and high and low prior knowledge groups. *Levene's* test for homogeneity was first conducted. For extraneous load,  $F(3, 95) = 1.662, p = .180$ , which does not reach significance. This indicates homogeneity and that the analysis of variance can be performed. The interaction effects between the two strategy groups and high and low prior knowledge groups resulted in  $F(3, 95) = .1212, p = .274$ , which does not reach significance. Thus, no interaction effects existed between the two strategy groups and high and low prior knowledge groups. As the interaction effects were not statistically significant, the main effects of the two strategy groups and high and low prior knowledge groups were examined.

The analysis result for the two strategy groups in extraneous load was  $F(3, 95) = .749, p = .389$ , which does not reach the level of significance. This means that the pretraining group and the segmented learning group displayed no significant differences in extraneous load. The analysis result for the high and low prior knowledge groups in extraneous load was  $F(3, 95) = 7.187, p = .009$ , which reaches the level of significance. Thus, the mean of extraneous load of the high prior knowledge group, 1.17, is significantly lower than that of the low prior knowledge group, 1.48.

### *Posttest score analysis*

To determine whether students with different levels of prior knowledge displayed differences in their posttest scores in the pertaining group and the segmented learning group, a two-factor analysis of variance was conducted with the posttest scores as the dependent variable and the high and low prior knowledge groups and the two strategy groups as the independent variables. *Levene's* test for homogeneity was first conducted. For the posttest scores,  $F(3, 95) = 1.512, p = .216$ , which does not reach significance. This indicates homogeneity and that the analysis of variance can be performed. The result of interaction effects between the two strategy groups and high and low prior knowledge groups was  $F(3, 95) = 7.021, p = .009$ , which reaches significance. Thus, significant interaction effects existed between the two strategy groups and high and low prior knowledge groups. As the interaction effects were statistically significant, the simple main effects of the two strategy groups and high and low prior knowledge groups were examined.

The prior knowledge groups were processed first. In the high prior knowledge group, the posttest score result was  $F(1, 48) = 8.339, p = .006$ , which indicates that the means of posttest score of the pretraining group, 7.25, is significantly higher than that of the segmented learning group, 5.35. In the low prior knowledge group, the posttest score result was  $F(1, 47) = .482, p = .491$ , which indicates no significant difference between the means of posttest score of the pretraining group, 3.28, and that of the segmented learning group, 3.67.

Next, the strategy groups were processed. In the pretraining group, the posttest score result was  $F(1, 47) = 53.501, p = .000$ , which indicates that the means of posttest score of the high prior knowledge group, 7.25, is

significantly higher than that of the low prior knowledge group, 3.28. In the segmented learning group, the posttest score result was  $F(1, 48) = 6.276, p = .016$  which means that the means of posttest score of the high prior knowledge group, 5.35, is significantly higher than that of the low prior knowledge group, 3.67.

## DISCUSSION

### Analysis of Research Conclusions

This study compared two strategies to manage intrinsic cognitive load, pretraining and segmented learning, using the unit Reference Quantities and Comparison Quantities in the sixth-grade mathematics curriculum in Taiwan. First, the researcher designed two sets of materials based on the two instructional strategies and then employed CLT to analyze the possible cognitive load that learners may face when using the two types of materials. Next, the researcher performed an experiment on learners with different levels of prior knowledge to investigate the influence of the instructional strategies on learning effectiveness and perceived cognitive load. At the same time, the multidimensional cognitive load scale developed by Leppink et al. (2013) was employed to gauge the cognitive loads perceived by the learners, assess the effectiveness of the multidimensional indicator, and thereby verify the results of our theoretical analysis. The researcher thereby arrived at the following conclusions.

#### *Pretraining results in lower cognitive load than segmented learning*

Existing CLT research on elementary school students used conventional single items as indicators of the cognitive load perceived by the students (Huang & Shie, 2016; Wong, Leahy, Marcus, & Sweller, 2012). However, misunderstanding of questionnaire items or insufficient sensitivity with regard to the indicators can lead to errors in the measurement of cognitive load. To overcome this, this study referred to the multidimensional cognitive load scale developed by Leppink et al. (2013) to measure the intrinsic and extraneous load perceived by the students. Use of this scale increased the validity of our finding that pretraining results in lower perceived cognitive load than segmented learning. This result is consistent with the researcher's hypothesis in that the different strategy groups displayed significant differences in intrinsic load but no significant differences in extraneous load. The results of the statistical analysis also verified the researcher's inference that pretraining results in significantly less intrinsic load. To further verify the accuracy of this analysis, the researcher also looked at how the students performed in the completion tasks while reading the materials. As the students had similar examples to refer to when they did the completion tasks, most of them obtained full marks. The practice scores did not follow a normal distribution, so the researcher adopted a nonparametric test to determine whether significant differences existed between the two strategy groups in the practice scores. The results of a *Mann-Whitney U* test showed significant differences between the two strategy groups with  $p = .000$ . During the learning process, the segmented learning group displayed significantly greater perceived cognitive load than the pretraining group, which affected their performance in the completion tasks. As a result, the practice scores of the students in the segmented learning group were significantly lower than those of the students in the pretraining group.

Furthermore, in both groups, the students in the high prior knowledge group presented significantly lower intrinsic load and extraneous load than the students in the low prior knowledge group. This also shows that prior knowledge indeed influences the intrinsic and extraneous load perceived by learners.

#### *Interaction effects between two strategy groups and high and low prior knowledge groups in posttest scores*

In the analysis of the posttest scores, interaction effects existed between the two strategy groups and the high and low prior knowledge groups, which means that prior knowledge indeed influences the instructional strategy adopted to manage intrinsic load. This is consistent with our inferences and the findings of previous research (Ayres, 2006a, 2013). However, statistical analysis revealed that among the students in the high prior knowledge group, those who experienced pretraining obtained significantly higher posttest scores than those in the segmented learning group, which is inconsistent with the researcher's hypothesis. The research speculates that this was because the students in the high prior knowledge group did not have sufficient prior knowledge to understand the segmented learning materials. The previous cognitive load indicator analysis revealed that the students in the pretraining group perceived lower cognitive load than those in the segmented learning group. The CLT emphasizes that when the cognitive load exceeds the learner's cognitive capacity, it affects his or her learning effectiveness. The researcher therefore infers that when the students in the high prior knowledge group were learning with the pretraining materials, the resulting cognitive load did not exceed their cognitive capacity. In contrast, the cognitive load resulting from the segmented learning materials exceeded the cognitive capacity of the high prior knowledge

**Table 2.** Statistics of student performance in first three problems of posttest

Instructional strategy group	Pretraining		Segmented learning		Subtotal	
	High	Low	High	Low	High	Low
Prior knowledge group						
Number of students	24	25	26	24	50	49
Application of single method	8	25	19	18	27	43
Subtotal	33		37			
Correct application of two methods	12	0	6	4	18	4
Subtotal	12		10			
Incorrect application of two methods	4	0	1	2	5	2
Subtotal	4		3			

students in the segmented learning group. As a result, the high prior knowledge students in the pretraining group obtained significantly higher posttest scores than those in the segmented learning group.

The statistical analysis results of the low prior knowledge group also did not support previous inferences: among the students in the low prior knowledge group, those in the pretraining group did not obtain significantly higher posttest scores than those in the segmented learning group. The researcher speculates that although the cognitive load indicator revealed that the cognitive load perceived by the pretraining group was lower than that perceived by the segmented learning group, the cognitive load resulting from both sets of materials still exceeded the cognitive capacity of the students in the low prior knowledge group. This resulted in no significant differences between the two groups of low prior knowledge students in the posttest scores.

To further verify the inferences above regarding the posttest scores of the students, the researcher analyzed the answers given by the students on the posttest. As mentioned in the section on research instruments, the first three problems in the posttest involved near transfer of learning. Based on the posttest scores in [Table 1](#), only the high prior knowledge students in the pretraining group obtained scores greater than 6 points, which means most of these students solved these three problems correctly. However, the mean score of high prior knowledge students in the segmented learning group did not reach 6 points, which means that even some of these students still could not solve all of the near transfer of learning problems correctly, let alone the low prior knowledge students in the two strategy groups, whose mean score was less than 6 points. This also indicates that the overall rate of answering the two far transfer of learning problems in the posttest was low. For this reason, the researcher only analyzed the performance of the students in the three near transfer of learning problems.

The first and third of these three problems involve an unknown comparison quantity, whereas the second problem involves an unknown reference quantity. The students must be able to identify which is the reference quantity and which is the comparison quantity and adopt two different problem-solving methods to solve these three problems correctly. Thus, the researcher divided the students based on the problem-solving methods that they used, namely application of only one methods, correct application of two methods, and incorrect application of two methods, and summarized the results in [Table 2](#).

As can be seen, half of the high prior knowledge students in the pretraining group could correctly apply two different methods to solve the three near transfer of learning problems, whereas less than a fourth of the high prior knowledge students in the segmented learning group could do so. Most of the low prior knowledge students in the two strategy groups could only apply one problem-solving method. Compared to the previous inferences, only the high prior knowledge students in the pretraining group perceived cognitive load within their cognitive capacities and were able to understand the two different problem-solving methods presented in the learning materials. The researcher speculates that this may be because the high prior knowledge students did not possess the two problem-solving sub-concepts in the materials, namely the drawing and interpretation of line segment diagrams. Thus, the element interactivity that they encountered while reading the segmented learning materials was still too high; aside from processing the information in the two steps, they also needed to process the integration of the two steps to solve the problem. This high element interactivity thus exceeded the cognitive capacity of the students. In contrast, the first part of the pretraining materials enabled students to focus on processing a single concept, and after reading two pairs of problems, most of the high prior knowledge students may already have had the sub-concept. When they subsequently read the explanation on how to apply the sub-concept to solve problems, they had already formed the sub-schema, which reduced the amount of element interactivity in the information. This enabled them to more successfully understand the content of the materials without exceeding their cognitive capacity and achieving better learning effectiveness.

For the low prior knowledge students, even though the pretraining materials enabled them to focus on processing a sub-concept, the provision of only two pairs of problems, one with an unknown reference quantity and the other with an unknown comparison quantity, was probably still not enough practice for them to establish the sub-concept. As for the students in the segmented learning group, the element interactivity was too high for even the high prior knowledge students, let alone the low prior knowledge students.



## Implications for Instruction

### *Instruction design for effective intrinsic load management*

Previous research shows that the unit regarding reference quantities and comparison quantities in the sixth-grade mathematics curriculum is problematic for many sixth-graders in Taiwan. This study designed two sets of materials to manage intrinsic cognitive load. It is hoped that instruction design can be viewed in a systematic manner to provide elementary school teachers with useful reference.

### *Appropriate instructional strategies based on learners' prior knowledge*

Although the instructional materials designed to manage intrinsic load in past studies have all succeeded in enhancing the learning effectiveness of learners, the results of this study indicate that for most older elementary school students who are accustomed to using a single skill or concept to solve problems, pretraining is probably a more suitable instructional strategy to manage intrinsic load. If teachers do not clearly understand what prior knowledge is necessary, segmented learning is a more difficult strategy to implement.

## ACKNOWLEDGEMENTS

This research was partially supported by Ministry of Science and Technology, Taiwan, R.O.C., under contract no. MOST 105-2410-H-142-007-MY2.

## REFERENCES

- Ayres, P. (2006a). Impact of reducing intrinsic cognitive load on learning in a mathematics domain. *Applying cognitive psychology*, 20, 287-298. <https://doi.org/10.1002/acp.1245>
- Ayres, P. (2006b). Using subjective measures to detect variations of intrinsic load within problems. *Learning and Instruction*, 16, 389-400. <https://doi.org/10.1016/j.learninstruc.2006.09.001>
- Ayres, P. (2013). Can the isolated-elements strategy be improved by targeting points of high cognitive load for additional practice? *Learning and Instruction*, 23, 115-124. <https://doi.org/10.1016/j.learninstruc.2012.08.002>
- Brünken, R., Seufert, T., & Paas, P., (2010). Measuring cognitive load. In J. L. Plass, R. Moreno, and R. Brünken (Eds.), *Cognitive load theory and research in educational psychology* (pp. 181-202). New York, NY: Cambridge University Press. [https://doi.org/10.1007/978-1-4419-8126-4\\_6](https://doi.org/10.1007/978-1-4419-8126-4_6)
- Clarke, T., Ayres, P., & Sweller, J. (2005). The impact of sequencing and prior knowledge on learning mathematics through spreadsheet applications. *Educational Technology, Research and Development*, 53, 15-24. <https://doi.org/10.1007/BF02504794>
- DeLeeuw, K. E., & Mayer, R. E. (2008). A comparison of three measures of cognitive load: evidence for separable measures of intrinsic, extraneous, and germane load. *Journal of Educational Psychology*, 100, 223-234. <https://doi.org/10.1037/0022-0663.100.1.223>
- Galy, E., Cariou, M., & Mélan, C. (2012). What is the relationship between mental workload factors and cognitive load types? *International Journal of Psychophysiology*, 83, 269-275. <https://doi.org/10.1016/j.ijpsycho.2011.09.023>
- Huang J. -C (Ed.) (2012). *Elementary Mathematics Textbook*, 12, Tainan, Taiwan, Nani Press.
- Huang, Y.-H., & Shie J.-T (2016). The Comparison of Two Mathematics Problem-Solving Strategies of Line-Diagram Representations on Learning Achievements. *Bulletin of Educational Psychology*, 47(4), 581-601. <https://doi.org/10.6251/BEP.20150603>
- Kalyuga S. (2015). *Instructional guidance: A cognitive load perspective*, Charlotte, NC, USA: Information Age Publishing.
- Kester, L., Kirschner, P. A., & van Merriënboer, J. J. G. (2004a). Information presentation and trouble -shooting in electrical circuits. *International Journal of Science Education*, 26(2/6), 239-256. <https://doi.org/10.1080/69032000072809>
- Kester, L., Kirschner, P. A., & van Merriënboer, J. J. G. (2004b). Just in time presentation of different types of information in learning statistics. *Instructional Science*, 32, 233-252. <https://doi.org/10.1023/B:TRUC.0000024191.27560.e3>
- Kester, L., Kirschner, P. A., & van Merriënboer, J. J. G. (2006). Just-in-time information presentation: Improving learning and troubleshooting skill. *Contemporary Educational Psychology*, 31, 167-185. <https://doi.org/10.1016/j.cedpsych.2005.04.002>

- Kester, L., Paas, P., & van Merriënboer, J. J. G. (2010). Instructional control of Cognitive Load in the Design of Complex Learning Environments., In J. L. Plass, R. Moreno, & R., Brünken (Eds.), *Cognitive load theory and research in educational psychology* (pp. 109-130). New York, NY: Cambridge University Press.
- Lee, Y.-C. (2013). *A Study of Line Segment Diagram Representation on Reference Quantity Problem Solving Performance for Sixth Grader* (Unpublished master's thesis), National Pingtung University of Education, Pingtung, Taiwan.
- Leppink, J., & van den Heuvel, A. (2015). The evolution of cognitive load theory and its application to medical education. *Perspectives on Medical Education*, 4, 119-127. <https://doi.org/10.1007/s40037-015-0192-x>
- Leppink, J., Paas, F., van der Vleuten, C. P. M., Van Gog, T., & van Merriënboer, J. J. G. (2013). Development of an instrument for measuring different types of cognitive load. *Behavior Research Methods*, 45(4), 1058-1072. <https://doi.org/10.3758/s13428-013-0334-1>
- Leppink, J., Paas, F., van Gog, T., van der Vleuten, C. P. M., & van Merriënboer, J. J. G. (2014). Effects of pairs of problems and examples on task performance and different types of cognitive load. *Learning and Instruction*, 30, 32-42. <https://doi.org/10.1016/j.learninstruc.2013.12.001>
- Mayer, R. E., & Moreno, R. (2003). Nineways to reduce cognitive load in multimedia learning. *Educational Psychologist*, 38, 43-52. [https://doi.org/10.1207/S15326985EP3801\\_6](https://doi.org/10.1207/S15326985EP3801_6)
- Mayer, R., & Moreno, R. E. (2010). Techniques that reduce extraneous cognitive load and manage intrinsic cognitive load during multimedia learning. In J. L. Plass, R. Moreno, & R. Brünken (Eds.), *Cognitive load theory and research in educational psychology*. (pp. 131-152). New York: Cambridge University Press. <https://doi.org/10.1017/CBO9780511844744.009>
- Pollock, E., Chandler, P., & Sweller, J. (2002). Assimilating complex information. *Learning and Instruction*, 12, 61-86. [https://doi.org/10.1016/S0959-4752\(01\)00016-0](https://doi.org/10.1016/S0959-4752(01)00016-0)
- Renkl, A., & Atkinson, R. K. (2010). Learning from worked-out examples and problem solving. In J. Plass, R. Moreno, & R. Brünken (Eds.), *Cognitive load theory and research in educational psychology* (pp. 91-108). New York: Cambridge University Press. <https://doi.org/10.1017/CBO9780511844744.007>
- Sweller, J. (1988). Cognitive load during problem solving: effects on learning. *Cognitive Science*, 12, 257-285. [https://doi.org/10.1207/s15516709cog1202\\_4](https://doi.org/10.1207/s15516709cog1202_4)
- Sweller, J. (2010a). Element interactivity and intrinsic, extraneous, and germane cognitive load. *Educational Psychology Review*, 22, 123-138. <https://doi.org/10.1007/s10648-010-9128-5>
- Sweller, J. (2010b). Cognitive load theory: recent theoretical advances. In J. L. Plass, R. Moreno, and R. Brünken (Eds.), *Cognitive load theory and research in educational psychology* (pp. 29-47). New York, NY: Cambridge University Press. <https://doi.org/10.1017/CBO9780511844744.004>
- Sweller, J., Ayres, P., & Kalyuga S. (2011) Altering Element Interactivity and Intrinsic Cognitive load, *Cognitive load theory* (pp. 203-218). New York, NY: Springer-Verlag.
- Wong, A., Leahy, W., Marcus, N., & Sweller, J. (2012). Cognitive load theory: The transient information effect and e-learning. *Learning and Instruction*, 22, 449-457. <https://doi.org/10.1016/j.learninstruc.2012.05.004>

<http://www.ejmste.com>

## How do Students Perceived Computerized Feedback as Effective?

Chin Sook Fui <sup>1\*</sup>, Lim Hooi Lian <sup>2</sup>

<sup>1</sup> Universiti Sains Malaysia, 11800 Gelugor, Penang, MALAYSIA

Received 20 October 2017 • Revised 9 February 2018 • Accepted 21 March 2018

### ABSTRACT

Feedback plays an important role in fostering deep learning. It is widely recognized as one of the most powerful influences on students' learning. Meanwhile, timeliness is one of the important elements for feedback to be effective. In line with the technology development, the trend of feedback delivery has been shifted from conventional written and oral feedback to computerized feedback. It can be planned and delivered to students in a timely manner. To fully utilize the advantage of computerized feedback, students' views should be taken into account. This study investigated students' perception on computerized feedback through semi-structured interviews. From the results, seven themes were identified: (1) Meaning, (2) Content, (3) Comprehensibility, (4) Usefulness, (5) Timeliness, (6) Emotion, and (7) Attention. The findings of this study emphasize the needs for understanding students' perceptions of computerized feedback to maximize its role in improving students' performance.

**Keywords:** feedback, perception, computerized feedback

### INTRODUCTION

Feedback is an essential element in learning that enables students to raise their level of awareness in relation to their strengths and also identify weaknesses which require further attention. Frequent and immediate feedback is critical for learning (Narciss & Huth, 2004). It is widely recognized as one of the most powerful influences on students' learning (Johnson, Reisslein & Reisslein, 2015). Through feedback, students can reflect back, know about what they are doing well and what do they need to improve. Without feedback, a test may promote misconceptions (Epstein et al., 2002). Timeliness is one of the important elements for feedback to be effective. According to Mutch (2003), it is important to give feedback to students within certain timelines when it is still meaningful to them. Students who received immediate feedback showed higher response identification accuracy, confidence rating and memory retention (Brosvic, Epstein, Cook, & Dihoff, 2005). They appreciate prompt feedback that could reveal misconceptions and convert their mistakes to correct answers (Cotner et al., 2008; Epstein et al., 2002).

With the rapid development of educational technologies, feedback delivered to students is not limited to face-to-face or written feedback. It can be delivered through computer-based testing (CBT). It has become one of the mediums in providing computerized feedback to students due to its ability in providing instant feedback to students. The trend of providing feedback has been shifting from a conventional handwritten way to the electronic version (Chang, Watson, Bakerson, & McGoron, 2013). Students' views on the computerized feedback could help to frame its effectiveness in the teaching and learning process. Meanwhile, every person tends to view things in different ways and with their own perspective. Understanding how students perceive their learning is vital (Tudor, Penlington, & McDowell, 2010). What students perceive from their learning situation will influence their performance and also their motivation in learning. Moreover, the condition for computerized feedback to be effective can be better understood when students' opinions are taken into account. Therefore, this study aims to contribute to build a richer picture of students' view of computerized feedback, by finding out how the computerized feedback is perceived by students.

**Contribution of this paper to the literature**

- Different feedbacks might yield different outcomes. This study aimed to understand how do students' perceived computerized feedback as effective which leads for future improvement.
- Feedback has to be delivered to students in a timely manner while it is still meaningful to students. This study also highlighted the advantage of using computer in giving immediate feedback to students.

**METHODOLOGY**

This study adopted qualitative research method. In this study, sampling was constrained to schools that are having computer lab, sufficient amount of computers and internet connection. School X which fulfilled this criteria and implements tracking system (students are divided into different classes according to their academic achievement) was chosen. Cluster sampling was used to select desired class to be involved. In total, ten Grade 7 students in one class were selected randomly (average age: 13 years old), as follow:

**Table 1.** Respondents involved

Race	Male	Female
1. Malay	A3, A7	A4, A6, A8
2. Chinese	A1	A2
3. Indian	A9	A5
4. Others	A10	-

\*A= Student

An algebraic expression misconceptions test was constructed and transformed into CBT test by using XAMPP and *phpMyAdmin*. XAMPP is a free and open source cross-platform web server solution stack package. It is designed for use as a development tool for web designer (Apache Friends, 2015). Meanwhile, *phpMyAdmin* is a free software tool written in PHP, intended to handle the administration of MySQL over the web.

In total, 22 items were constructed by referring to textbooks and reference books published locally. The allocated time for the test is 40 minutes. Computerized feedback was presented to the students after an answer was clicked which comprised of the four major components (Correctness, Information, Reinforce, and Directive guide). **Figure 1** and **2** show the example of screenshot of the detailed feedback given. With the feedback provided, students gained information about their answer and proceeded to the next question after that until all 22 items were answered.

**Figure 1.** Example of Detailed Feedback Presented to the Students (Correct Response)

<p>NAMA: Student A NO. KP : 123456789</p> <p style="text-align: center;"><b>Bahagian C – Me</b></p> <p style="text-align: center;"><b>Soalan 14</b></p> <p><b>Simplify</b>    <math>2(d + 2) - (-d + 5)</math></p> <p> <input type="radio"/> A. <math>12d</math>  <input type="radio"/> B. <math>d + 9</math>  <input type="radio"/> C. <math>3d + 9</math>  <input type="radio"/> D. <math>5d + 5</math> </p>	<p style="text-align: center;"><b>Feedback</b></p> <p>The correct answer is "C".</p> <p>The purpose of this question is to simplify algebraic expression by combining "like terms". Do you know that in algebra, letter is used to represent a variable?</p> <p>Example: Alan runs Y meter. The variable is Y.</p> <p>Terms with similar variables can be simplified: <math>3d + 9d = 12d</math></p> <p>However, terms with different variables can NOT be simplified. <math>3d + 9 \neq 12d</math></p> <p><b>Sample Answer:</b></p> $2(d + 2) - (-d) + 5$ $= (2 \times d) + (2 \times 2) - (-d) + 5$ <p style="text-align: right; border: 1px solid gray; padding: 2px;">Ok</p>
--	--

**Figure 2.** Example of Detailed Feedback Presented to the Students (Wrong Response)

### Semi-structured Interview

Students' perceptions on the feedback were investigated by using semi-structured interviews. A semi-structured interview instrument was adapted from Rowe and Wood (2008) to assess students' perceptions towards feedback for several reasons. Firstly, the instrument was designed to explore students' perception of feedback. Secondly, the instrument was designed based on the themes identified and extracted from the qualitative data. Thirdly, Budge (2011) also adapted this instrument in his study to assess students' perception of electronic feedback. The interview instrument comprises of 11 questions and required about 30 minutes to complete. Trustworthiness of the interview instrument was facilitated by the following steps:

- (a) Member Check – Member check is "taking data and tentative interpretations back to the people whom they were derived and asking them if the results are plausible" (Merriam, 2001, p. 204). After the interviews were transcribed, the transcripts were validated by the students. This can ensure that the findings' resembled students' perception on the feedback designed in this study.
- (b) Language Used to Interview the Participants – The language used in the interview between researcher and students are important. Without using language that is mastered by students, communication barrier might happen and the response received might not be complete or accurate. In this study, researcher used Malay and Mandarin language when interviewing the students.
- (c) Interrater reliability – Interrater reliability (also known as consistency estimate) is used to assess the degree to which different raters make consistent estimates of the same phenomenon. It is important to examine interrater reliability so that data collected in this study is correct representations of the variable measured. In this study, semi-structured interview data was recorded by using audio-taping. It was then coded by two raters. Then, Cohen's kappa was used to examine the interrater reliability. From the analysis, there was substantial agreement between the two raters,  $k = 0.671$  ( $p < 0.001$ ).

### Research Procedure

There were two main sessions involved: (a) Session One – Intervention and (b) Session Two – Interview. During the intervention phase, all students took the CBT individually. Computerized feedback was presented after every question was answered, which consists of four elements: (a) Correctness, (b) Information, (c) Reinforce, and (d) Directive guide. Post-interviews were conducted individually by the researcher with the students to determine their perceptions on the feedback presented in Session 2. During the interviews, the researcher took note and audio-taped the interview. Audio-taping is convenient and reliable to ensure that the original data is available at any time (Gay, Mills, & Airasian, 2009). Following audio-taped data collection, the recordings were transcribed for analysis purpose.

## RESULTS

In this study, key themes that best summarized the students' perceptions towards the computerized feedback were identified: (1) Meaning, (2) Content, (3) Comprehensibility, (4) Usefulness, (5) Timeliness, (6) Emotion, and (7) Attention. They were then further analyzed and compared evidence from the different data sets. To protect the identity of the interviewees, all names used are pseudonyms.

### Meaning

**Table 2.** Meaning of CBT Feedback

Category	Number of Students	Examples of selected statement
Explanation of Correct Answer	4 out of 10 A1, A3, A5, A6	"那个答案的解释哦... 还有它给的答案, 那个题目的答案怎样来的 · 做法 (An explanation for the [correct] answer... and the answer given by it [feedback], how to get the answer for that question, [its] working solution)" (Interview A1).
		"Maklumbalas boleh... apa ini... dia... tolong kita kasih betul... dia bagi penjelasan yang lebih terang (Feedback can... somehow... it... helps us in correcting... it gives clearer explanation)" (Interview A3).
		"supaya dapat buat [soalan] lebih baik (to do [question] better)" (Interview A3).
		"maklumbalas itu... itu... macam respond lar, penerangan... penjelasan... kasih tahu [kita] jawapan [yang betul] lar... cara buat soalan. [Jadi, kita] dapat buat lebih baik (Feedback is... is... like a response, elaboration... explanation lar... tells [us] the [correct] answer... method to do the question. [So, we] can do better)" (Interview A5).
Knowledge	2 out of 10 A2, A8	"Kasih tahu [saya] jawapan lar... cara buat [jawab] soalan (Let [me] know [the] answer lar... method to do [answer] question)" (Interview A6).
		"可以让我知道很多知识的东西 (Knowledge that makes me learns a lot)" (Interview A2).
Information	4 out of 10 A4, A7, A9, A10	"Memberi... menyebabkan... kita... belajar... [saya] dapat belajar sesuatu lar! (Give... let... us... learn... [I] can learn something lar!" (Interview A8).
		"satu... pengajaran yang... memberi maklumat yang penting (a... lesson that... gives important information)" (Interview A4).
		"Mm... macam maklumat yang... diberi... tentang sesuatu (Mm... like information...regarding something)" (Interview A7).
		"Macam... dia bagi cara macam mana mahu buat (Like... it shows the method on how to do)" (Interview A9).
		"Supaya kita faham maklumat itu (To let us understand the information)" (Interview A10).

\*I= Interviewer; S = Student

From the interview data, students perceived CBT feedback as: (a) explanation of correct answer, (b) knowledge, and (c) information.

### Content

All students agreed that the content of the CBT feedback received was sufficient. There is no extra information should be added in the CBT feedback. In addition, five students expressed further that the CBT feedback presented is informative. Meanwhile, two students further described the content of the CBT feedback as accurate and relevant.



**Table 3.** Content of CBT Feedback

Category	Number of Students	Examples of selected statement
Sufficient	10 out of 10	I: <i>Adakah informasi dalam maklumbalas yang dipaparkan mencukupi? 它给你的资料够不够?</i> (Is the information given sufficient?) S: 够! (Sufficient!)
	A1, A2, A3, A4, A5, A6, A7, A8, A9, A10	I: <i>够啦? 解释了之后你很清楚那个题目了?</i> (Sufficient? After the explanation, can you understand the question?) S: 啊! (Yes!) (Interview A1)
Informative	5 out of 10	I: <i>Adakah informasi dalam maklumbalas yang dipaparkan mencukupi? 它给你的资料够不够?</i> (Is the information given sufficient?) S: Ya (Yes!) (Interview A6)
		" <i>sebab dia bagi... macam... anu... jawapan yang betul, dan dia bagi tahu kenapa... baca dia... boleh kasih [saya] faham</i> (Because it gives... like... mm... correct answer, and it tells [me] why)" (Interview A5)
		" <i>Ya... dia [maklumbalas]... banyak maklumat lar... (Yes... it [feedback]... a lot of information lar...)</i> (Interview A6)
		S: <i>Saya... tahu lar.. agak-agak... kan dia banyak bagi penerangan... dia tunjukkan informasi lar...</i> (I... know lar... roughly... it gives lot information... it shows the information lar...) I: Oh, banyak informasi terkandung di dalam maklumbalas itu? (Oh, is there a lot of information in the feedback?) S: Ya. (Yes.) (Interview A7)
Accurate & Relevant	2 out of 10	" <i>Boleh... itu... dia [maklumbalas] tunjukkan jawapan, ada banyak maklumat lagi...</i> (Can... it... it [feedback] shows the answer, a lot of information)" (Interview A8)
		" <i>Dia bagi tahu [saya] jawapan yang betul, sama... [langkah] kerja yang... betul</i> (It tells [me] the correct answer, and... the right... [working] solution)" (Interview A9).
		" <i>Dia [maklumbalas] menerangkan soalan itu... tidak lari tajuk!</i> (It [feedback] explains the question... not deviated from the topic!)" (Interview A3).
		I: <i>Adakah informasi dalam maklumbalas yang dipaparkan mencukupi? Kenapa?</i> (Is the information in the feedback sufficient?) S: <i>Ya, mencukupi</i> (Yes, sufficient) I: <i>Kenapa?</i> (Why?) S: <i>Dia punya... soalan itu... lengkap lar!</i> (Its... question... complete lar!) I: <i>Maksudnya, maklumat dipaparkan itu, lengkap?</i> (Does it mean, the information in the feedback, complete?) S: <i>Ya</i> (Yes) (Interview A10)

\*I= Interviewer; S = Student

## Comprehensibility

Although most of the students were satisfied with the content of the CBT feedback given, most of them are having comprehensibility problem.

Only two students (Student A1 and A10) felt that the CBT feedback presented is easy to understand. Meanwhile, eight students cannot understand the CBT feedback well. They were having difficulty in understanding the CBT feedback in some degree. They found that it is hard to catch what the CBT feedback meant due to two main factors. Firstly, it is due to the language used. The CBT feedback delivered was presented by using Malay language. This might be a disadvantage for non-native speakers such as Chinese and Indian students.

**Table 4.** Comprehensibility of CBT Feedback

Category	Subcategory	Number of Students	Examples of selected statement
Understand well		2 out of 10	I: <i>Ok... Adakah anda faham maklumbalas yang dipaparkan?</i> (Ok, do you understand the feedback presented?) S: Ya. (Yes)
		A1, A10	I: <i>意思说你读那个句子你明白?</i> (Does it mean that, you can understand the sentences?) S: <i>明白</i> (Understand)" (Interview A1)  " <i>Boleh lar... tidak berapa susah nak faham</i> (Can lar... not really hard to understand)" (Interview A10)
Partly understand	Language	2 out of 10	I: <i>Adakah ayat itu senang difahami?</i> (Is the sentence easy to understand?) S: <i>Mm... sikit-sikit</i> (Mm... a bit) I: <i>Sikit-sikit? Kenapa?</i> (A bit? Why?) S: <i>Ada perkataan yang saya tak faham.</i> (There are some words that I can't understand.) I: <i>Perkataan yang [kamu] tak faham? Contohnya?</i> (Words that [you] can't understand? For example?) S: <i>... .. dia itu... tak faham maksud... er... perkataan... (... .. its... can't understand the meaning... er... words...)</i> I: <i>Sebah Bahasa Melayu yang digunakan itu susah?</i> (Is it because of the Malay language used is difficult?) S: <i>Ya!</i> (Yes!) (Interview A6)
		A2, A6	" <i>tak berapa faham. Mm... sikit-sikit saja yang faham. Sebab... sebab... susah dia... susah mahu faham</i> ".  " <i>Dia... tidak kasih jelas... buat jelas kasih bagi...dia tidak kasih jelas terang kalau buat...</i> (It... didn't show it clear... make it clearer... it didn't make it clearer... )."  " <i>ayat itu terlalu panjang... tak... tak seberapa jelas. Macam... saya tidak faham apa yang dia... kasih jelas! Caranya itu</i> (the sentence is too lengthy... not... not that clear. Like... I can't understand what it is... trying to make it clear!" (Interview A3).  " <i>Sikit- sikit... ayat tidak jelas</i> (A bit... the sentences are not clear)" (Interview A5)  " <i>Ada yang faham, ada yang tidak faham. Sebab... mungkin... ayat itu terlampau susah</i> (Can understand some, but some are not. Because... maybe... the sentence is too difficult)" (Interview A8)  " <i>...ayat itu, saya tak berapa faham.</i> (...the sentence, I not really understand)" (Interview A9).
	Sentences	6 out of 10	
		A3, A4, A5, A7, A8, A9	

\*I= Interviewer; S = Student

Besides, another factor is due to the sentences of the CBT feedback. For examples, Student A5 shared her experience in understanding the sentences in the CBT feedback and Student A8 commented that he can only understand the CBT feedback partly due to its complexity

## Usefulness

In the interviews, most of the students viewed CBT feedback as highly important. They repeatedly commented on the usefulness of the CBT feedback delivered. In particular, students described how they benefited from the CBT feedback. In general, there are two categories that arose in this theme: (a) error detection, and (b) error correction.

**Table 5.** Usefulness of CBT Feedback

Category	Number of Students	Examples of selected statement
Error Detection	8 out of 10	"检讨... 错在哪里... 看它算出来那个方法... 那个讲解 (reflect... what is wrong... look at the solution presented... that explanation)" (Interview A2).
	A1, A2, A3, A4, A5, A6, A8, A10	"Selepas baca [maklumbalas], [saya] tahu kesilapan [saya] (After reading [the feedback], [I] know [my] error)" (Interview A3).  "Selepas baca maklumbalas, boleh tahu... boleh tahu kenapa salah... ah... salah di mana (After reading the feedback, can know... can know... why wrong... ah... which part is wrong)" (Interview A5).
Error Correction	8 out of 10	"因为它可能第五题问的东西... 在第六题只是那号码变了罢了... 做法还是一样的 (Because the thing [question] asked in Question 5... In Question 6, what has changed is the number only, working solution is still the same" (Interview A1).
	A1, A2, A3, A4, A5, A6, A8, A10	"Sebab... kalau soalan pertama salah, dia bagi maklumbalas, [jadi] soalan seterusnya [saya] dapat jawab dengan senang (Because... if the first question is wrong, it gives feedback, [so, I] can answer the next question easily" (Interview A4).  "Dalam... pengiraan. Dia punya soalan... tolak-tolak... kadang-kadang... mm... serupa (In... calculation. The question... minus, minus... sometimes... mm... identical) (Interview A10).
Not benefited	2 out of 10	I: Jadi, bagi kamu, kamu rasa... maklumbalas itu tidak membantu kamu dalam menjawab soalan yang seterusnya? (So, for you, do you think that... the feedback is not helpful for you in answering the next question?) S: Ya. (Yes.) I: Biar pun maklumbalas itu menunjukkan jawapan yang betul? (Even though it shows you the right answer?) S: Ya. (Yes.) (Interview A7)
		"Tidak, sebab susah mahu faham (No, because hard to understand)" (Interview A9).

\*I= Interviewer; S = Student

### Error detection

When the students were being asked whether the CBT feedback presented was helpful in reflecting their mistake, eight students agreed (A1, A2, A3, A4, A5, A6, A8, and A10). Student A1 expressed that he knew his mistake after reading the CBT feedback. Generally, he read through the feedback without spending much time on it, but paid more attention if his answer was wrong. By looking on the example solution shown in the feedback, he was able to identify his error (Interview A1). Similarly, Student A2 claimed that the CBT feedback delivered helped her to detect the error did.

### Error correction

In line with the use of CBT feedback in error correction, eight students (A1, A2, A3, A4, A5, A6, A8, and A10) perceived that CBT feedback is useful in error correction and improving their performance. For example, Student A1 shared that he read the CBT feedback and learnt the right way to solve the question. When came across to the next question which was similar to the previous question, he was able to get it right. From this, there is one important point has to be highlighted that, error correction is notable in similar questions. This is further ascertained by the experience shared by Student A10. He agreed that the CBT feedback helped him to correct his error in questions which are identical. As another example, Student A4 shared that CBT feedback gave her better picture on how to answer the question correctly. In turn, she performed better in the next question.

However, Student A8 commented that the CBT feedback presented helped him to correct his error and perform better in the next question, but not exclusively. This means that, after reading the feedback, in the next question, sometimes he got correct but sometimes got wrong.

### Timeliness

In this study, the CBT feedback was given to the students right after they answered a question. From the interviews, it is clear that students were aware of the immediate appearance of feedback. All students interviewed expressed that they prefer immediate feedback. As for example, Student A2 prefers immediate. For her, receiving answers after answering all questions is difficult for her to remember and identify her mistake. Meanwhile Student A5 preferred immediate feedback because she can't wait to know the result.

**Table 6.** Timeliness of CBT Feedback

Category	Number of Students	Examples of selected statement
Immediate	10 out of 10	"第一时间可以知道自己错哪里嘛!如果是...等到最后才给的话啦... [我] 就不知道这题是哪一题的答案了 (Can know where I did wrong at the first place! If... it is given at the end... [I] couldn't know which question is this answer belongs to)" (Interview A1).
	A1, A2, A3, A4, A5, A6, A7, A8, A9, A10	"嗯...卷子就不用...呃...可以答一题就直接接收到一题的答案, 不用还有等到最后才...呃...一起...比较难 (Mm... In this way, no need... er... can receive an [answer] directly after answering a question, no need to wait until the end... er... together... more difficult" (Interview A2).
		"Sebab macam...kalau dia [ujian berdasarkan komputer] bagi feedback itu kan, senang mahu... fikir, kalau soalan seterusnya (Because... if it [CBT] gives feedback, easier to... think, for next question)". (Interview A3)
		I: <i>Andakah anda lebih suka mendapat maklumbalas dengan serta-merta?</i> (Do you like to receive feedback immediately?) S: Ya. (Yes.) I: <i>Kenapa?</i> (Why?) S: <i>Tak sabar nak tahu keputusan</i> (Can't wait to know the result.) (Interview A5)

\*I= Interviewer; S = Student

### Emotion

In line with their preference of the timeliness of feedback, the data in this study reveals that most of the students were having positive emotional impact after receiving immediate feedback through CBT.

Nine students were having positive emotion when receiving CBT feedback. As in the example, Student A1 felt excited when receiving CBT feedback immediately after he answered the question, no matter it is correct or wrong. He did not feel pressured if got wrong answer, but tried to find out his mistake by looking at the solution presented in the CBT feedback (Interview A1).

Similarly, Student A2, A4 and A5 shared that they felt "happy" when receiving the CBT feedback. In the particular, Student A2 expressed that she felt happy because she can know whether her answer was correct or not. Even though when her answer was wrong, this triggered her to look deeply on the feedback, tried to find out why she got it wrong:

However, Student A3 expressed different emotion with other students. From the immediate feedback, he was able to know whether he got correct or wrong. However, for him, this created the feeling of tension in some degree.

**Table 7.** Emotion towards CBT Feedback

Category	Number of Students	Examples of selected statement
Positive	9 out of 10 A1, A2, A4, A5, A6, A7, A8, A9, A10	<p>I: 酱你的...感觉是怎样的? 如果你... 一答了之后, 你看到那个maklumbalas走出来, 你的感觉是什么的? (Then... how was your feeling? If you... after you answered, you saw the feedback appeared, what was your feeling?)</p> <p>A2: 开心! (Happy!)</p> <p>I: 做么开心? (Why happy?)</p> <p>A2: 因为我可以知道我自己对... 我知道我自己对还是错。(Because I can know that I am correct... I know that whether I am correct or wrong) (Interview A2)</p> <p>"Lega kerana dapat jawapannya (Relief because get the answer)" (Interview A7)</p> <p>"Puas hati, lebih yakin lar... sebab tahu jawapannya (Satisfiy, more confident lar... because know the answer)" (Interview A8).</p>
Negative	1 out of 10 A3	"tertekan... sebab... sebab... takut salah (Pressured... because... because... afraid of getting wrong)" (Interview A3).

\*I= Interviewer; A3 = Student A3

### Attention

Even though students perceived that the content of CBT feedback delivered was sufficient and important in detecting and correcting error, it is quite surprising that six students did not pay full attention on it.

As for example, Student A1 paid attention on the CBT feedback only when his answer was wrong. Besides, Student A2 admitted that she did not read through all the CBT feedback presented because of her "laziness". Other than that, Student A7 also expressed that he did not pay full attention on the CBT feedback. For him, he has no interest in reading all the sentences written in the feedback. He admitted honestly that he skipped the description in the feedback and only look at the example answer (working solution) provided.

Due to the poor students' attention towards the feedback presented, it is not surprising that most of them (nine out of ten) were not able recall and give example of the CBT feedback viewed.

**Table 8.** Attention towards CBT Feedback

Category	Number of Students	Examples of selected statement
Fully Attended	4 out of 10 A3, A5, A6, A8	I: <i>Okey, jadi, adakah anda memberi perhatian ke atas maklumbalas yang dipaparkan?</i> (Ok, so, do you pay attention on the feedback shown?) S: Ya! (Yes!) I: <i>Baca semua?</i> S: Ya! (Yes!) (Interview A3)
		I: <i>Ok, adakah anda memberi perhatian atas maklumbalas yang dipaparkan?</i> (Ok, do you pay attention on the feedback shown?) S: Ya. (Yes.) I: <i>Membaca dengan teliti?</i> (Read in detail?) S: Ya. (Yes.) I: <i>Membaca setiap perkataan?</i> (Read every word?) S: Ya. (Yes) (Interview A5)
		I: <i>Adakah anda memberi perhatian atas maklumbalas yang dipaparkan?</i> (Do you pay attention on the feedback shown?) S: Ya. (Yes.) I: <i>Membaca setiap perkataan atau dengan jawapan sahaja?</i> (Read every word or read the answer only?) S: <i>Baca semua... apa yang ditunjukkan itu lar!</i> (Read all... what is written there lar!) I: <i>Maksudnya kamu memberi perhatian yang sepenuhnya ke atas maklumbalas itu?</i> (Means, you paid full attention on the feedback, isn't?) S: Ya. (Yes.) (Interview A6)
Partly Attended	6 out of 10 A1, A2, A4, A7, A9, A10	" <i>因为[答案]对的就不用读了嘛! 只是看错的才读[反馈]啦!</i> (Because no need to read if [the answer] is correct! Read [the feedback] only when [the answer] is wrong!) (Interview A1)
		" <i>懒惰读。因为很多国语字我看不懂</i> (Lazy to read. Because there are many Malay words which I can't understand)" (Interview A2).
		" <i>Tengok jawapan sahaja lar!</i> (Look at the answer only lar!)" (Interview A7).
		I: <i>Jadi, adakah kamu memberi perhatian? Atas maklumbalas yang dipaparkan, melalui komputer itu?</i> (So, did you pay attention? On the feedback shown through computer?) S: <i>Ada lar</i> (Ya, I did) I: <i>Sepenuhnya? Memberi perhatian sepenuhnya?</i> (Fully? Paid attention fully?) S: <i>Tidak juga</i> (Not really) I: <i>Jadi?</i> (So?) S: <i>Er... tak baca semua, cuma... baca sikit-sikit... kan dia [maklumbalas] panjang... banyak... ar...</i> (Er... didn't read all, just... read a bit... it [feedback] is long... a lots... arg...) (Interview A10)

\*I= Interviewer; S = Student

### Summary of Students' Perception towards CBT Feedback

From the qualitative data, students' perception towards CBT feedback presented through CBT in this study is summarized in [Table 9](#).



**Table 9.** Summary of Students' Perception towards CBT Feedback

Themes	Category	Description
1. Meaning	a. Explanation of Correct Answer	Students perceived CBT feedback as explanation of correct answer, knowledge or information.
	b. Knowledge	
	c. Information	
2. Content	a. Sufficient	All students perceived that the content of CBT feedback presented is sufficient. In particular, the feedback is informative, accurate and relevant to the topic.
	b. Informative	
	c. Accurate & Relevant	
3. Comprehensibility	a. Understand well	Most of the students are having comprehensibility problem on the CBT feedback presented. There are two major factors identified: language and sentences.
	b. Not understand	
	i. Language	
	ii. Sentences	
4. Usefulness	a. Error Detection	Most of the students agreed that the CBT feedback is useful in improving their performance which helps them in error detection and error correction.
	b. Error Correction	
	c. Not benefited	
5. Timeliness	Immediate	All students expressed that they prefer immediate feedback.
6. Emotion	a. Positive	Most of the students are having positive emotion towards the CBT feedback presented. Only one student commented that he felt pressured.
	b. Negative	
7. Attention	a. Fully attended	More than half of the students admitted that they paid attention partly to the CBT feedback presented, some even expressed that they looked at the correct answer only instead of all information presented.
	b. Partly attended	

## DISCUSSION & CONCLUSION

Perception is important in understanding how a person thinks and gives meaning to something. Understanding how students perceive the feedback delivered through CBT is vital. What students perceive from their learning situation will influence their performance and also their motivation in learning (Annie, 2011). From the interview results, a richer picture of students' view of the computerized feedback was gained. Based on the results, students perceived feedback as explanation of correct answer, knowledge, and information. On the other hand, all students agreed that the content of feedback is sufficient. It is informative, accurate and relevant to the topic. Thus, it is useful in detecting errors made and correcting the error to improve their performance. This is in line with the findings by Randall and Zundel (2012) that students viewed feedback as useful as it indicated what they had done correctly and provide guidance to improve their performance. Moreover, the feedback presented is not only providing the correct answer (simple feedback), but also the verification that allow students to correct their error (answer feedback). As reported by Marsh (2012), answer feedback is necessary to maximize error correction.

Besides, students pointed out that they were able to identify their errors made from the feedback given. This shows that the feedback is useful in error detection. As supported by Mitrovic (2010), feedback plays the role of a mentor and informs the students of the errors made. Through feedback, students are able to judge their level of understanding and become aware of their errors made (Mason & Bruning, 2001). Similarly, the students also expressed that the feedback is useful in error correction. After reading the feedback, they were most likely not going to repeat the same error again. This is supported by Marsh (2012) that feedback is helpful in correcting students' errors. As pointed out by Gipps (1999, p.46), "*learners require feedback in order to learn*", students have the chance to learn from their error through feedback. It is an essential element in raising their awareness in relation to their errors which require further attention. In contrast, in the study by Kuiper and Pater-Sneep (2014), students expressed that they did not benefited from the feedback because what they had done wrong is not pointed out. Hence, this emphasizes the importance of the content of feedback given to students. It should be informative, especially able to point out students' weakness. Subsequently, help them to detect and correct their errors.

Despite the use of feedback in detecting and correcting errors, students admitted that there is inconsistency in error correction. Not all the students were able to correct their error in the subsequence similar question(s) nor they were able to correct their error absolutely afterward. This means that sometimes they answer the next question correctly after reading the feedback, but sometimes they get it wrong. For examples:

Scenario 1

*Student P answered Question 1 wrongly and received feedback. He was able to answer Question 2 (similar with Question 1) correctly.*

Scenario 2

*Student P answered Question 1 wrongly and received feedback. He was not able to answer Question 2 (similar with Question 1) correctly.*

Scenario 3

*Student P answered Question 1 wrongly and received feedback. He was able to answer Question 2 (similar with Question 1) correctly. However, he got wrong in Question 3 (similar with Question 1 and 2).*

The inconsistency in error correction might due to students' attention to the feedback provided. Although students viewed the feedback as useful, not all of them were paying full attention on it. Some students admitted that they only read the feedback when their answer is wrong, skipped through the feedback when their answer is correct. Besides, some of them even expressed that they looked at the correct answer (working solution) only rather than read through every sentences written in the feedback. This is in line with the study by Timmers and Veldkamp (2011) that attention paid to the feedback provided by a CBT varies greatly. In their study, fifty percent of the students paid attention to feedback of incorrect answers only. Meanwhile, twenty-five percent of the students did not pay attention to feedback at all. They suggested that the attention paid to feedback is influenced by task difficulty and test length. Despite emphasizing on the content and criteria of feedback, the findings of this study also reveal that there is a need to enhance students' attention on the feedback provided, especially their self-awareness of the importance of feedback have to be cultivated. Instead of trying the best to give feedbacks, teachers and educators should also help students to recognize the importance of feedback, be aware of the existence of feedback and how to utilize feedback in their learning. They have to know the importance of feedback and value the feedback received. Otherwise, it is a waste of designing and showing feedback to the students yet the outcome is not as fruitful as expected.

Besides, most of the students pointed out that they were having comprehensibility problem with the feedback presented. This reinforces the point made by Higgins (2000, p.1) that, "*Many students are simply unable to understand feedback comments and interpret them correctly.*" Similarly, Carless (2006) found that some students perceived that they could interpret the feedback given but some found it is hard to decipher handwritten feedback or catch what the meaning in the feedback. Even though the feedback used in this study was proposed and designed carefully to ensure that it is clear and easy to understand, the findings reveals that there are two major factors affecting the comprehensibility of feedback among the students: (a) language and (b) sentences. It is in line with the study by Carless (2006) that even though the feedback was given on specifics, some students perceived that they could interpret the feedback given but some found it is hard to understand what the feedback meant. This triggers the idea about concerning students' language background and ability in giving feedback.

In terms of timeliness, all students prefer immediate feedback. They expressed that immediate feedback enables them to know the correct answer quickly, giving them chance to make improvement and build confidence. It is supported by Lilley, Barker, and Britton (2005) that students like to be assessed and get value comments on their achievement. Besides, Sambell, Sambell and Sexton (1999) suggest that lack of feedback can lead to student demotivation. Immediate feedback can provide remedial information constantly and avoiding confusion (Siegel & Misselt, 1984). Therefore, receiving feedback immediately motivates their passion in engaging actively in learning.

While the feedback presented is considered as positive feedback, most of the students are having positive feeling towards the appearance of feedback right after they answered a question. Feedbacks presented were written in positive component, such as "well done, keep it up!" and "good jobs". Negative statements such as "you are wrong" and "you are weak" are avoided. Affirmation instead of criticism was applied. As support that Hattie and Timperley (2007) and Lalor (2012) that affirmation must be given to students, emphasize their strengths and what's they need to do next to improve their learning. It should be descriptive rather than judgmental. This is in line with the study by Barrow, Mitrovic, Ohlsson, and Grimley (2008), which positive feedback provides assurance and reduces uncertainty to students. Hence, students are willing to receive the feedback presented, no matter their answer or correct as not. The findings of this study underline the significance of the role of positive component in a feedback.

## IMPLICATIONS

This study pinpoints to advantage of the use of CBT in giving immediate feedback to students. Despite the importance of feedback, the frequency of feedback given to students in classroom is low due to the big teachers-to-students ratio, teachers' limited time and many responsibilities/tasks in school. One of the key advantage of CBT is students can be assessed and receive valuable feedback on their performance immediately. From the findings, students preferred immediate feedback which delivered by CBT. They were motivated and able to detect and correct their errors. This may encourage teachers and educators to use it as a tool to provide detailed and instant feedback to students in a timely manner.

## LIMITATIONS

There are some limitations in this study. Firstly, this study involves only Form One (Grade Seven in United States) secondary school students in Sabah, Malaysia. Besides, even though there are many subtopics in algebra, this study focuses on algebraic expressions, which is one of the topics in Form One Mathematics syllabus. Second, feedback is a powerful tool that provides information to students regarding their performance on certain tasks given. When feedback is given to students, certain criteria need to be met for it to be effective, especially promptness and timeliness. Therefore, computer-based testing was used as the medium of test in this study. For some students who are not computer literate, they might find difficulty in answering questions through computer. The effect of computer literacy on students' performance is beyond the scope of this study.

Besides, to ensure the consistency of feedback given to students, selected-response items is used in this study instead of open-ended questions. Students can only choose an answer from the distractors given, in which were designed by the researcher by referring to previous literature review and pilot study. The potential to investigate deeper about the errors is limited. Only targeted errors in this study can be included in the distractors.

## REFERENCES

- Annie, T. (2011). Exploring students' perception of and reaction to feedback in school-based assessment. *Malaysian Journal of ELT Research*, 7(2), 104-147.
- Apache Friends. (2015). What is XAMPP? Retrived from <https://www.apachefriends.org>
- Barrow, D., Mitrovic, A., Ohlsson, S., & Grimley, M. (2008). Assessing the impact of positive feedback in constraint-based tutors. In *ITS 2008, The 9th International Conference on Intelligent Tutoring Systems*, Montreal, Canada. [https://doi.org/10.1007/978-3-540-69132-7\\_29](https://doi.org/10.1007/978-3-540-69132-7_29)
- Brosvic, G. M., Epstein, M. L., Cook, M. J., & Dihoff, R. E. (2005). Efficacy of error for the correction of initially incorrect assumptions and of feedback for the affirmation of correct responding: learning in the classroom. *Psychological Record*, 55(3), 401-418. <https://doi.org/10.1007/BF03395518>
- Budge, K. (2011). A desire for the personal: student perceptions of electronic feedback. *International Journal of Teaching and Learning in Higher Education*, 23(3), 342-349.
- Carless, D. (2006). Differing perceptions in the feedback process. *Studies in Higher Education*, 31(2), 219-233. <https://doi.org/10.1080/03075070600572132>
- Chang, N., Watson, B., Bakerson, M. A., & McGoron, F. X. (2013). Undergraduate students' perceptions of electronic and handwritten feedback and related rationale. *Journal of Teaching and Learning with Technology*, 2(2), 21-42.
- Cotner, S. H., Fall, B. A., Wick, S. M., Walker, J. D., & Baepler, P. M. (2008). Rapid feedback assessment methods: Can we improve engagement and preparation for exams in large-enrollment courses? *Journal of Science Education and Technology*, 17(5), 437-443. <https://doi.org/10.1007/s10956-008-9112-8>
- Epstein, M. L., Lazarus A. D., Calvano, T. B., Matthews, K. A., Hendel, R. A., Epstein, B. B., & Brosvic, G. M. (2002). Immediate feedback assessment technique promotes learning and corrects inaccurate first responses. *The Psychological Record*, 52, 187-201. <https://doi.org/10.1007/BF03395423>
- Gay, L. R., Mills, G. E., & Airasian, P. (2009). *Educational research: Competencies for analysis and applications* (9th Ed.). Upper Saddle River, NJ: Pearson
- Gipps, G. R. (1999) Using Assessment Strategically to Change the Way Students Learn. In Brown, S. & Glasner, A. (Eds.), *Assessment Matters in Higher Education - Choosing and Using Diverse Approaches*. London. Society for Research in Higher Education and Open University Press, 41-53.
- Hattie, J., & Timperley, H. (2007). The power of feedback. *Review of Educational Research*, 77(1), 81-112. <https://doi.org/10.3102/003465430298487>

- Higgins, R. (2000). 'Be more critical': rethinking assessment feedback. Paper presented to *British Educational Research Association Conference*, Cardiff University, 7-10 September.
- Johnson, A. M., Reisslein, J., & Reisslein, M. (2015). Transitional Feedback Schedules During Computer-based Problem-solving Practice. *Computers & Education*, 81, 270-280. <https://doi.org/10.1016/j.compedu.2014.10.020>
- Kuiper, E., & Pater-Sneep, M. (2014). Student perceptions of drill-and-practice mathematics software in primary education. *Mathematics Education Research Journal*, 26(2), 215 - 236.
- Lalor, A. (2012). Keeping the destination in mind. *Educational Leadership*, 70(1), 75-78.
- Lilley, M., Barker, T. & Britton, C. (2005). The generation of automated learner feedback based on individual proficiency levels. *Proceedings of the 18th International Conference on Industrial & Engineering Applications of Artificial Intelligence & Expert Systems, Lecture Notes in Artificial Intelligence*, 3533, 842-844. [https://doi.org/10.1007/11504894\\_115](https://doi.org/10.1007/11504894_115)
- Marsh, E. A. (2012). Using verification feedback to correct errors made on a multiple-choice test. *Memory*, 20(6), 645-653. <https://doi.org/10.1080/09658211.2012.684882>
- Mason, B. J., & Bruning, R. (2001). *Providing feedback in computer-based instruction: What the research tells us*. Center for Instructional Innovation, University of Nebraska-Lincoln: 14. Retrieved from: <http://dwb.unl.edu/Edit/MB/MasonBruning.html>
- Merriam, S. B. (2001). *Qualitative Research and Case Study Application in Education*. San Francisco: Jossey-Bass Publishers.
- Mitrovic, A. (2010). Modeling domains and students with constraint-based modeling. In R. Nkambou, J. Bourdeau, & R. Mizoguchi (Ed.), *Advances in intelligent tutoring systems* (Vol. 308, pp. 63-80). Berlin Heidelberg: Springer. [https://doi.org/10.1007/978-3-642-14363-2\\_4](https://doi.org/10.1007/978-3-642-14363-2_4)
- Mutch, A. (2003). Exploring the practice of feedback to students. *Active Learning in Higher Education*, 4, 24-38. <https://doi.org/10.1177/1469787403004001003>
- Narciss, S., & Huth, K. (2004). How to design informative tutoring feedback for multi-media learning. In *Instructional Design for Multimedia Learning*, edited by H. M. Niegemann, D. Leutner, and R. Brünken, pp. 181-195. Münster: Waxmann.
- Randall, L., & Zundel, P. (2012). Students' perceptions of the effectiveness of assessment feedback as a learning tool in an introductory problem-solving course. *Canadian Journal for the Scholarship of Teaching and Learning*, 3(1), 1-15. <https://doi.org/10.5206/cjsotl-rcacea.2012.1.3>
- Rowe, A. D., & Wood, L. N. (2008). Student perceptions and preferences for feedback. *Asian Social Science*, 4(3), 78-88.
- Sambell, K., Sambell, A., & Sexton, G. (1999). Student perceptions of the learning benefits of computer-assisted assessment: a case study in electronic engineering. In Brown, S., Race, P. & Bull, J. (Ed.), *Computer-assisted assessment in higher education* (Chapter 19, 179-192). London: Kogan Page/SEDA.
- Siegel, M. A., & Misselt, A. L. (1984). Adaptive feedback and review paradigm for computer-based drills *Journal of Educational Psychology*, 76(2), 310-317. <https://doi.org/10.1037/0022-0663.76.2.310>
- Timmers, C., & Veldkamp, B. (2011). Attention paid to feedback provided by a computer-based assessment for learning on information literacy. *Computer & Education*, 56(3), 923-930. <https://doi.org/10.1016/j.compedu.2010.11.007>
- Tudor, J., Penlington, R., & McDowell, L. (2010). Perceptions and their influences on approaches to learning. *Journal of the Higher Education Academy Engineering Subject center*, 5(2), 69-79. <https://doi.org/10.11120/ened.2010.05020069>

<http://www.ejmste.com>

# The Depression and Creativity of Design-Major Students

Eva Chang<sup>1</sup>, Rain Chen<sup>2\*</sup>

<sup>1</sup> Independent Designer, Tainan, TAIWAN

<sup>2</sup> Southern Taiwan University of Science and Technology, Tainan, TAIWAN

Received 25 December 2017 • Revised 6 March 2018 • Accepted 7 March 2018

## ABSTRACT

In Taiwan, the rise of design industry recently has greatly increased the demand of design professionals. The design related departments has also been increased gradually. A designer's emotion can directly affect the design output, and designers with negative emotion may unconsciously project their negative emotion onto the design. The objective of the study is to discuss the association between design-major students with depressive tendency (DT) and their creativity. In this study, ten works from creators with DT and ten from creators without depressive tendency (NoDT) were examined by 123 subjects (as the audience) to explore the association between the creative works and emotional projection from the perspective of the audience. The result suggests that audience's preference and feeling of happiness of the 20 works are positively correlated. Those works making the audience happy are also liked, while those making the audience unhappy are disliked. Whether the audience has depression or not is not a factor affecting their perception of the works, but for creators, they would produce less liked works because of their depressive tendency.

**Keywords:** depression, creativity, design-major students, design education

## INTRODUCTION

Modern people lead a fast-paced life and stay tensed constantly because of the tremendous pressure from competition. As a result, more and more people experience negative emotion related psychiatric disorders. Among various types of neurosis, depression has the greatest impacts. According to the disability-adjusted life year as index from World Health Organization (WHO), the report of global burden of disease has predicted that depression would become the second highest burdened disease of DALY among the diseases in the world in 2020 (Murray & Lopez, 1996). WHO has also announced depression, cancer and AIDS as the three major diseases of the century. There are many factors associated with depression, such as genes, changes in biochemical substances, diseases, drugs, personality traits, and perceptual losses and pressure. Studies have shown that human genes and emotion are closely related; for example, the short allele of gene 5-HTTLPR could increase the risk of depression and suicide (Fox, Ridgwell, & Ashwin, 2009).

Studies have shown that the age and depression has negative correlation. For people with age 18 to 38, the depressive tendency is more obvious with the increase of the age (Steer, Ball, Ranier, & Beck, 1999). The most serious result of Depression is suicide. In United States, suicide is the third major cause of death for teenagers aged 15 to 24, and is the sixth major cause of death for children aged 5 to 14. Many adults with Chronic Depression have suffered from depression during the teenager or child period (Waslick, Schoenholz, & Pizarro, 2003). Depression limits the academic achievement of the teenagers, affecting their self-care ability, causing disabled and unable to take care their daily life, and even causing them to suicide. This causes important health problem of the students and cannot be neglected (Fulkerson et al., 2004; Pelkonen, Marttunen, & Aro, 2003; Smith & Blackwood, 2004). Freshmen enter the new learning environment. The challenge from schoolwork and interpersonal relationship may cause the freshmen to have doubts about the personal ability, and affect their self-concept (Cassidy & Trew, 2004). Studies have shown that low self-identity and huge pressure would cause depressive mood and evading the issue of the teenagers. In the long term, it may risk the physical and mental development of the university students



#### Contribution of this paper to the literature

- Regarding what the audience perceives of a work, there is a positive correlation between happy-unhappy and like/dislike.
- NoDT's works are more liked by the audience, and NoDT's works also make the audience happier.
- DT's works are less liked by the audience, and DT creators can be affected by depression tendency and create less liked works.

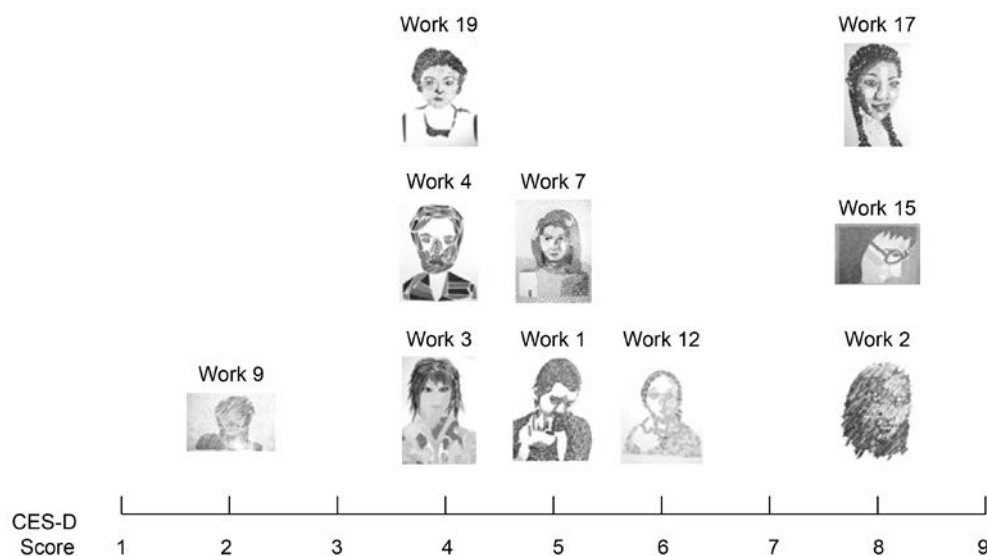
(Martyn-Nemeth et al., 2009). Many freshmen leave the hometowns that provide security and identity. However, they still have not blended in with the new environment and may eventually experience loss (Chow & Healey, 2008). Simultaneously, since the network is common, many university students overindulge in the Internet, for which it may cause issues on physiology, psychology, social intercourse and specialty, such as depression, anxiety, regression of academic and professional performance, insomnia, health issue and social withdrawn (Beard, 2005; Griffiths, 2000; Young, 1998, 2004).

According to the seriousness of Depression, there will be different therapy. In addition to medication, there are other therapy approaches. Seasonal affective disorder (SAD) is a mental illness associated with a lack of sun exposure, and SAD patients would experience seasonal mood swing. One common practice to handle SAD is to give the patients light therapy, and indeed, numerous studies have demonstrated that light therapy has a significant effect on SAD (Eastman et al., 1998; Ruhrmann et al., 1998). Art therapy is a helping profession that combines creative artistic expression and psychotherapy. In art therapy, the artistic media is applied for creative artistic expression of visual imagery. Through the expression of imagery, the personal thought, emotion, interest, ability and personality would be reflected and integrated. Art therapy has begun since the early 1900s. The paintings of the patients were applied for diagnosis and analysis. The actual professional development started from the psychiatric treatment movement in 1930-1940. Affecting by the concept from Sigmund Freud and Carl Gustav Jung, art becomes the media of communication and integration for psychoanalysts treating the children (Mcwhinnie, 1985). The paintings of the children reflect their personalities. The painting behaviors of the children reflect their personality emotional state (Farokhi & Hashemi, 2011). By applying painting as the media, the art therapy could integrate the linguistic and non-linguistic communication between left and right hemispheres of the brain. The imagery and image of the painting activity could be applied to arouse the linguistic expression of patients suffering from anxiety and depression, and improve the reaction and healing effect to the patients suffering from depression (McNamee, 2004). The development of art therapy combines different theory models and psychotherapy, including psychology, philosophy, aesthetics and art (Blatner, 1991; Lusebrink, 1991; Stamatelos & Mott, 1983).

Aside from letting the therapist understand their clients, art therapy also allows the clients to use perception as a communicative bridge for connecting the internal self to the external world (Zambelli, Clark, & Hodgson, 1994). Art is used by creators for expressing their thoughts and ideas, while the creative works can be viewed as an interface allowing creators to communicate with the outside. When a patient is not willing to use words or languages to express their thoughts, artworks can function as a communication tool bridging the patient to the therapist. Many studies used artworks as clues for the subjects to express their internal affection, thoughts, and feelings using concrete colors and shapes (McNamee, 2004; Ulman, 1992). Aside from using the media of artworks as clues, there are also studies using art creation as a type of therapy. The characteristics of the children reflected on the paintings are similar to the behavioral characteristics in the social situation. The art reflects the personality emotional state of the children (Farokhi & Hashemi, 2011). There is "externalization" for artistic creation, which allows people infusing the thought and emotion into the artistic media. The persons involved are allowed to infuse into their created works no matter it is related to something they like or hate. The artworks are improved continuously in the creative process. It is also true for artists, who keep on developing and get the new meaning. If the artists are too emotional or lacks of emotional compatibility to the artistic works, there would be negative effect to the articles (Sullivan & McCarthy, 2009).

In art therapy, the patients suffering from depression infuse the feeling into the works in the creating process during artistic creation. Designers also show their ideas from the works. There are more and more evidences showing that there are correlation between depression and certain cognitive functions, such as selective attention, message processing and obvious obstacle to working memory (Garcia-Toro et al., 2003; Koetsier et al., 2002; Landro, Stiles, & Sletvold, 2001; Nebes et al., 2003; Schatzberg et al., 2000). There is considerable correlation between origin of job pressure and depression (Jurado et al., 2005; Mausner-Dorsch & Eaton, 2000; Whooley et al., 2002). In Taiwan, the booming of the design industry increases the needs for design personnel. There is also a graduate increase over the years in the number of design related schools. Designers' emotion can directly affect their design output. Depressive mood of the designers affect their choice of color matching (Wu, Chang, & Lee, 2009). Designers with negative emotion often unconsciously infuse their negative emotion into their design products, which can be important because their products may be widely distributed on the market and be massively used. Designers use





**Figure 1.** Ten of the "Self-Portrait" Mosaic Creation Works belong to Creators with a Low CES-D Score

their professional expertise to integrate the sensual quality into the design, but what if a designer has a negative emotion and projects the negative emotion onto the works? Would the audience perceive the negative feeling? The study examined the projection of depressive mood onto creative works from the perspective of the audience and of the creators respectively.

## METHOD

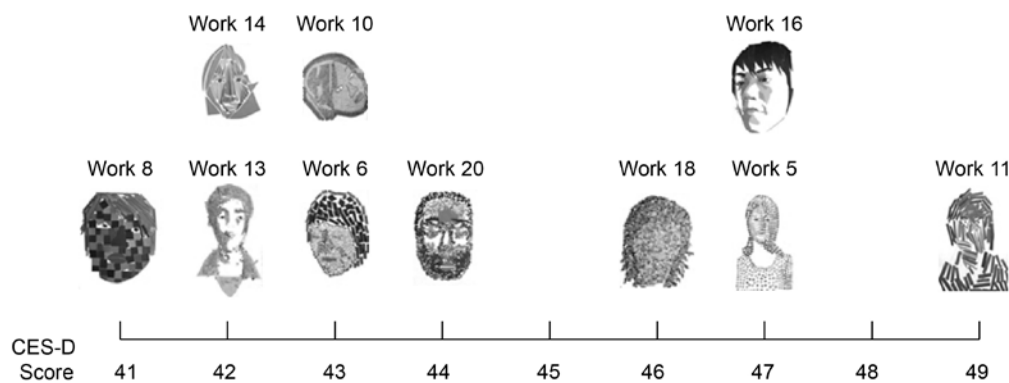
### Subjects

All the subjects (N = 123; 65 males and 58 females) participated in the experiments are Taiwanese and design-major students. Their average age is 19.14 years old. They all took the Ishihara Color Deficiency Test and verified that they are not color blinds (Ishihara, 1993).

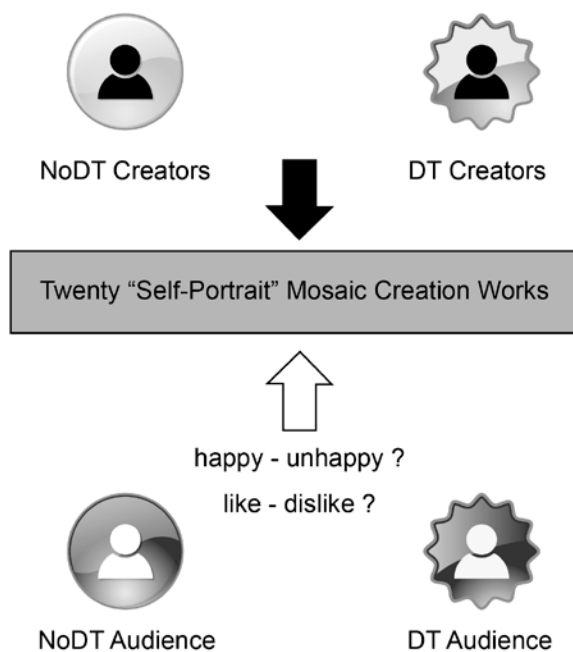
### Experimental Materials

The Center for Epidemiologic Studies Depression (CES-D) scale is a commonly applied self-report depression scale that has 20 question items (Carleton et al., 2013; Radloff, 1977, 1991). CES-D was originally used for assessing the depression condition of adults, but in recent years, it has been found that CES-D is also good and solid for children and adolescents (Edman et al., 1999; Olsson, Nordstrom, Arinell, & von Knorring, 1999; Prescott et al., 1998). Therefore, the study used CES-D for determining the level of depression. For youngsters, mood swing is a developmental feature during the adolescent phase, and because of mood swing, the optimal cutoff point for screening adolescent depression is higher than for adults (Ghubash et al., 2000). Because the study subjects are Taiwanese, the optimal cutoff point of depression is 29 (Yang, Soong, Kuo, Chang, & Chen, 2004). In addition, because adolescents are more likely to experience mood swing, instead of using the term "depression", it is recommended to use "depressive tendency" to refer to adolescents with the depression disorder. The subjects of the study were divided into two groups: depressive tendency (DT) and no depressive tendency (NoDT). Among the 123 subjects, who are all design-major students, their optimal cutoff point is 29, and 42 of them are DT (34%) while 81 are NoDT (66%).

For selecting the creative works, the study picked 10 with the lowest CES-D and 10 with the highest CES-D from the 233 works of "self-portrait" mosaic creation of relevant scholars (Wu, 2009). In "self-portrait" mosaic creation, the subjects are asked to create a work about self-image by pasting up different color blocks. Among the 233 works of "self-portrait" mosaic creation, ten of the works belong to creators with a low CES-D score (ranged from 2 to 8 points), making them the NoDT (See Figure 1). While another ten works belong to creators with a high CES-D score (ranged from 41 to 49 points), making them the DT (See Figure 2).



**Figure 2.** Ten of the “Self-Portrait” Mosaic Creation Works belong to Creators with a High CES-D Score



**Figure 3.** Emotional Projection on Creative Works from Perspectives of Audience and Creators

### Experimental Design

The objective of the study is exploring emotional projection on creative works from perspectives of audience and creators (See [Figure 3](#)). For the creator part, the study picked 20 works from other research papers (Wu, 2009). For the audience, in order to prevent mood swing associated with pressure from school exams, the experiment was conducted two weeks after the mid-term exam. To avoid interfering with the study objectives, the audiences were not informed about the objective of the experiment; they were only told to fill out the CES-D and the semantic differential scale.

The objective of semantic differential scale is to determine the most direct perceived value of a work rated by the audience (Taft, 1997). Because the study is related to depressive mood, terms like, dislike, happy, and unhappy were directly used as relative adjectives. For the questionnaire, it has a 7-point rating scale for quantifying two categories, like-dislike (preference) and happy-unhappy (happiness), perceived by the subjects for the 20 works. The center of the scale is neutral and has a score of zero. As we move toward the left end of the scale, the level of like increases, and the score also increased from 1 to 2 and to 3. If we move toward the right end of the scale, the level of dislike also increases, and the score changes from -1 to -2 and to -3. The works are presented randomly to increase the reliability.

**Table 1.** Correlation Analysis of Audience’s Perceived Happiness of the 20 Works

	1	2	3	4	5	6	7	8	9	10
r	0.57**	0.69**	0.55**	0.80**	0.59**	0.71**	0.68**	0.81**	0.70**	0.55**
p	0.00	0.00	0.00	0.00	0.00	0.00	0.00	0.00	0.00	0.00
	11	12	13	14	15	16	17	18	19	20
r	0.59**	.60**	0.58**	0.70**	0.45**	0.45**	0.70**	0.52**	0.63**	0.71**
p	0.00	0.00	0.00	0.00	0.00	0.00	0.00	0.00	0.00	0.00

**Table 2.** Mean and SD of Works of NoDT Creators Rated by Audience: Like-Dislike

Work	1	2	3	4	7	9	12	15	17	19
Mean	-0.20	-0.11	-1.75	-0.21	0.92	-0.30	0.71	1.05	0.85	0.30
SD	1.65	1.78	1.34	1.70	1.50	1.80	1.72	1.50	1.51	1.65

## RESULTS

### Semantic Differential Scale Results

The questionnaire comprises two themes: like-dislike and happy-unhappy. The obtained responses about the 20 works were submitted to correlation analysis. **Table 1** shows correlation analysis results of the audience’s perceived happiness of the 20 works. It can be found that for each work, there is a positive correlation between like-dislike and happy-unhappy of the audience. That is, those works that make the audience happy are also liked, while those making the audience unhappy are disliked.

### Emotional Projection of Works from the Audience’s Perspective

Among the 20 works, the most liked work is Work 16 (1.25±1.51), while the most disliked work is Work 3 (-1.75±1.34). As for happy and unhappy, Work 17 made most audience feel happy (1.18±1.57), while Work 8 made most audience feel unhappy (-1.55±1.62).

From analyzing the correlation between CES-D score and the audience’s perception of the works using correlation analysis, it was found that only Work 1 has a negatively correlation between CES-D score and preference ( $r=-0.19$ ,  $p=0.0$ ); other works showed no significant correlation. The statistical results suggest that the audience’s higher depression tendency (i.e., a higher CES-D score) is associated with a higher level of dislike of Work 1, but for the remaining 19 works, the audience’s perception is not affected by depression tendency. The audience’s CES-D and the perceived happiness of the 20 works are not significantly correlated.

The study divided the audience into two groups, DT and NoDT, to explore whether depressive mood can affect the perception of creative works. Among the 20 works, Work 16 is the one most liked by DT and NoDT, while Work 17 is the work that makes both DT and NoDT feel happy. An independent simple t-test was conducted to compare the DT and the NoDT groups regarding the audience’s like-dislike and happy-unhappy of the 20 works. For like-dislike, no difference was found between DT and NoDT for 17 out of the 20 works; only Work 1 ( $f=3.49$ ,  $p<0.05$ ), Work 2 ( $f=7.78$ ,  $p<0.05$ ), and Work 6 ( $f=4.05$ ,  $p<0.05$ ) showed a significantly difference. For NoDT, they showed a greater preference for Work 1 and Work 2 than DT did. More specifically, Work 1 is liked by NoDT (0.03) but disliked by DT (-0.62). As for Work 6, NoDT disliked the work more than DT did.

For perceived happiness, independent simple t-test results show a lack of difference from 19 out of the 20 works. The only work with significant difference is Work 2 ( $f=4.46$ ,  $p<0.05$ ). NoDT (-0.75±1.52) perceived less happiness from Work 2 than DT did (-0.63±1.87).

### Exploring Emotional Projection in Creative Works from the Creator’s Perspective

Among the 20 works, ten of them are from NoDT while the other ten are from DT. Overall, the ten NoDT creators’ works are more liked by the audience (0.13±1.61), and the audience are also more likely to feel happy about their works (-0.14±1.61). The other ten works from DT creators are less liked by the audience (-0.65±1.61), and the audience are also more likely to feel unhappy about their works (-0.93±1.51). For the perception of like-dislike, half of the works from the ten NoDT creators are liked by the audience (see **Table 2**), while for the ten works from DT creators, only Work 16 is liked by the audience (see **Table 3**). For the perception of happiness, four out of the ten works by NoDT creators are perceived more toward the happy side (see **Table 4**), while all the ten works by DT creators are perceived as unhappy (see **Table 5**).

**Table 3.** Mean and SD of Works of DT Creators Rated by Audience: Like-Dislike

Work	5	6	8	10	11	13	14	16	18	20
Mean	-0.53	-1.33	-1.35	-0.07	-1.38	-0.04	-0.46	1.25	-1.52	-1.05
SD	1.53	1.51	1.76	1.68	1.67	1.71	1.55	1.51	1.52	1.62

**Table 4.** Mean and SD of Works of NoDT Creators Rated by Audience: Happy-Unhappy

Work	1	2	3	4	7	9	12	15	17	19
Mean	-0.81	-0.71	-1.43	-0.53	0.47	-0.02	-0.29	0.68	1.18	0.04
SD	1.67	1.64	1.37	1.59	1.55	1.85	1.64	1.67	1.57	1.53

**Table 5.** Mean and SD of Works of DT Creators Rated by Audience: Happy-Unhappy

Work	5	6	8	10	11	13	14	16	18	20
Mean	-0.50	-1.31	-1.55	-0.76	-1.50	-0.63	-0.78	-0.02	-1.27	-1.03
SD	1.47	1.38	1.62	1.39	1.45	1.63	1.35	1.60	1.59	1.65

**Table 6.** Cross-Comparison of Like-Dislike between DT and NoDT Audience for Works of NoDT Creators

Audience	Like-Dislike for works of NoDT creators							Total
	-3	-2	-1	0	1	2	3	
No depression (N)	72	70	132	158	162	126	84	804
Expected	84.9	82.2	125.7	154.0	150.0	123.0	84.2	804.0
Column %	5.9%	5.7%	10.8%	12.9%	13.3%	10.3%	6.9%	65.8%
With depression (N)	57	55	59	76	66	61	44	418
Expected	44.1	42.8	65.3	80.0	78.0	64.0	43.8	418.0
Column %	4.7%	4.5%	4.8%	6.2%	5.4%	5.0%	3.6%	34.2%
Total	129	125	191	234	228	187	128	1222
Expected	129.0	125.0	191.0	234.0	228.0	187.0	128.0	1222.0
Column %	10.6%	10.2%	15.6%	19.1%	18.7%	15.3%	10.5%	100.0%

To further explore the impact of depression tendency on the association between the audience and the creators, the study did the chi-square analysis on the audience with or without depression tendency and works of creators with or without depression tendency. The results suggest that the audience with or without depression tendency is significantly correlated with their preference for works of NoDT creators ( $\chi^2=15.29$ ,  $p=0.02$ ), but the audience with or without depression tendency is not correlated with their preference for works of DT creators ( $\chi^2=10.23$ ,  $p=0.11$ ), with the perceived happiness of works of NoDT creators ( $\chi^2=8.99$ ,  $p=0.17$ ), or with the perceived happiness of works of DT creators ( $\chi^2=5.28$ ,  $p=0.51$ ). In **Table 6**, under a significant level of  $p=0.05$ , depression tendency or not of the audience is significantly correlated with their preference for works of NoDT creators. Nonetheless, because the Cramer's V coefficient is 0.11, the correlation is not strong.

## DISCUSSION AND CONCLUSIONS

The study examined the effect of depression tendency through the perception of the audience. Creators would project their emotion onto their works, while the audience can perceive the emotion through the style or the quality of the creative works. Here are the conclusions.

- (1) Regarding what the audience perceives of a work, there is a positive correlation between happy-unhappy and like/dislike. In other words, the tendency of depression cannot affect the perception of the audience. Moreover, most people like works that make them feel happy while dislike works that make them unhappy.
- (2) The correlation between the audience's CES-D score and their perceived happiness of or preference for the 20 works is insignificant. Only one significantly negative correlation was found from the preference of Work 1. Therefore, what the audience perceives about a work is not affected by the level of depression, and the audience with depression tendency showed that they dislike Work 1. The creator of Work 1 used lots of red and orange colors; in fact, Work 1 is the work among all the 20 works that has red been used the most. Studies have shown that there is a correlation between color perception and depression, and the finding here can be further explored in the future.
- (3) NoDT's works are more liked by the audience, and NoDT's works also make the audience happier. In contrast, DT's works are less liked by the audience, and DT creators can be affected by depression tendency and create less liked works.

- (4) From the cross-comparison between the audience and the creators, it can be found that there is no significant correlation between whether the audience has a tendency of depression or not and works of creators with or without tendency of depression. A significant correlation was only found between the audience and the preference for works of NoDT creators, but the correlation is not strong.

Leo Nikolayevich Tolstoy (1828-1910) remarked that "Art is a human activity consisting in this, that one man consciously, by means of certain external signs, hands on to others feelings he has lived through, and that other people are infected by these feelings and also experience them". This research also shows that the creators' feelings are connected with their works. The study results demonstrated that the tendency of depression does not have much influence on the perception of audience, but it has impacts on the works of creators. When creators have a tendency of depression, they would project the emotion onto the works, which would be less liked by audience and make the audience unhappy.

Presently, Taiwan has been working hard on shifting away from OEM. In this case, a good design industry can effectively elevate the competitiveness of companies. As a result, the country shall be depending on all design-major students to speed up the development of the country. Positive emotion leads to positive energy (Barnhofer et al., 2009; Kenny & Williams, 2007; Ma & Teasdale, 2004), and products with positive energy can bring the audience positive and good feelings. If research can demonstrate that the projection of emotion by the designer onto the works can indeed affect the audience, such information shall point out an important direction for the government in cultivating design-major students in the future and should be applied on the education and development of design-major students in order to infuse positive energy into the design industry.

## REFERENCES

- Barnhofer, T., Crane, C., Hargus, E., Amarasinghe, M., Winder, R., & Williams, J. M. (2009). Mindfulness-based cognitive therapy as a treatment for chronic depression: A preliminary study. *Behaviour Research and Therapy*, 47, 366-373. <https://doi.org/10.1016/j.brat.2009.01.019>
- Beard, K. W. (2005). Internet addiction: A review of current assessment techniques and potential assessment questions. *Cyber Psychology and Behavior*, 8(1), 7-14. <https://doi.org/10.1089/cpb.2005.8.7>
- Blatner, A. (1991). Theoretical principles underlying creative arts therapies. *The Art in Psychotherapy*, 18(5), 405-409. [https://doi.org/10.1016/0197-4556\(91\)90052-C](https://doi.org/10.1016/0197-4556(91)90052-C)
- Carleton, R. N., Thibodeau, M. A., Teale, M. J. N., Welch, P. G., Abrams, M. P., Robinson, T., & Asmundson, G. J. G. (2013). The Center for Epidemiologic Studies Depression Scale: A Review with a Theoretical and Empirical Examination of Item Content and Factor Structure. *PLoS One*, 8, e58067. <https://doi.org/10.1371/journal.pone.0058067>
- Cassidy, C., & Trew, K. (2004). Identity change in Northern Ireland: A longitudinal study of students' transition to university. *Journal of Social Issues*, 60(3), 523-540. <https://doi.org/10.1111/j.0022-4537.2004.00370.x>
- Chow, K., & Healey, M. (2008). Place attachment and place identity: First-year undergraduates making the transition from home to university. *Journal of Environmental Psychology*, 28, 362-372. <https://doi.org/10.1016/j.jenvp.2008.02.011>
- Eastman, C. I., Young, M. A., Fogg, L. F., Liu, L., & Meaden, P. M. (1998). Bright light treatment of winter depression: A placebo-controlled trial. *Archives of General Psychiatry*, 55, 883-889. <https://doi.org/10.1001/archpsyc.55.10.883>
- Edman, J. L., Danko, G. P., Andrade, N., McArdle, J. J., Foster, J., & Glipa, J. (1999). Factor structure of the CES-D (center for epidemiologic studies depression scale) among Filipino-American adolescents. *Social Psychiatry and Psychiatric Epidemiology*, 34, 211-215. <https://doi.org/10.1007/s001270050135>
- Farokhi, M., & Hashemi, M. (2011). The analysis of children's drawings: Social, emotional, physical and psychological aspects. *Social and Behavioral Sciences*, 30, 2219-2224. <https://doi.org/10.1016/j.sbspro.2011.10.433>
- Fox, E., Ridgewell, A., & Ashwin, C. (2009). Looking on the bright side: biased attention and the human serotonin transporter gene. *Proceedings of the Royal Society B*, 276, 1747-1751. <https://doi.org/10.1098/rspb.2008.1788>
- Fulkerson, J. A., Sherwood, N. E., Perry, C. L., Neumark-Sztainer, D., & Story, M. (2004). Depressive symptoms and adolescent eating and health behaviors: a multifaceted view in a population-based sample. *Preventive Medicine*, 38, 865-875. <https://doi.org/10.1016/j.ypmed.2003.12.028>
- Garcia-Toro, M., Talavera, J. A., Gonzalez, E., Tejada, P., Blanco, C., Gonzalez, A., & Saiz-Ruiz, J. (2003). Audioverbal cognitive dysfunction in depression. *Factors involved. Progress in Neuropsychopharmacology and Biological Psychiatry*, 27, 37-42. [https://doi.org/10.1016/S0278-5846\(02\)00312-3](https://doi.org/10.1016/S0278-5846(02)00312-3)



- Ghubash, R., Daradkeh, T. K., Al Naseri K. S., Al Bloushi N. B., & Al Daheri A. M. (2000). The Performance of the Center for Epidemiologic Study Depression Scale (Ces-D) in an Arab Female Community. *International Journal of Social Psychiatry*, 46(4), 241-249. <https://doi.org/10.1177/002076400004600402>
- Griffiths, M. (2000). Internet addiction-time to be taken seriously? *Addiction Research*, 8(5), 413-418. <https://doi.org/10.3109/16066350009005587>
- Ishihara, S. (1993). *Ishihara's test for color-blindness*. Tokyo: Kanehara.
- Jurado, D., Gurpegui, M., Moreno, O., Fernandez, M. C., Luna, J. D., & Galvez, R. (2005). Association of personality and work conditions with depressive symptoms. *European Psychiatry*, 20, 213-222. <https://doi.org/10.1016/j.eurpsy.2004.12.009>
- Kenny, M. A., & Williams, J. M. (2007). Treatment-resistant depressed patients show a good response to Mindfulness-based Cognitive Therapy. *Behaviour Research and Therapy*, 45, 617-625. <https://doi.org/10.1016/j.brat.2006.04.008>
- Koetsier, G. C., Volkens, A. C., Tulen, J. H., Passchier, J., van den Broek, W. W., & Bruijn, J. A. (2002). CPT performance in major depressive disorder before and after treatment with imipramine or fluvoxamine. *Journal of Psychiatric Research*, 36(6), 391-397. [https://doi.org/10.1016/S0022-3956\(02\)00026-2](https://doi.org/10.1016/S0022-3956(02)00026-2)
- Landro, N. I., Stiles, T. C., & Sletvold, H. (2001). Neuropsychological function in nonpsychotic unipolar major depression. *Neuropsychiatry, Neuropsychology, & Behavioral Neurology*, 14, 233-240.
- Lusebrink, V. B. (1991). A system oriented approach to the expressive therapies: The expressive therapies continuum. *The Arts in Psychotherapy*, 18(5), 395-403. [https://doi.org/10.1016/0197-4556\(91\)90051-B](https://doi.org/10.1016/0197-4556(91)90051-B)
- Ma, S. H., & Teasdale, J. D. (2004). Mindfulness-Based Cognitive Therapy for Depression: Replication and Exploration of Differential Relapse Prevention Effects. *Journal of Consulting and Clinical Psychology*, 72(1), 31-40. <https://doi.org/10.1037/0022-006X.72.1.31>
- Martyn-Nemeth, P., Penckofer, S., Gulanick, M., Velsor-Friedrich, B., & Bryant, F.B. (2009). The relationships among self-esteem, stress, coping, eating behavior, and depressive mood in adolescents. *Research in Nursing & Health*, 32, 96-109. <https://doi.org/10.1002/nur.20304>
- Mausner-Dorsch, H., & Eaton, W. W. (2000). Psychosocial work environment and depression: Epidemiologic assessment of the demand-control model. *American Journal of Public Health*, 90, 1765-1770. <https://doi.org/10.2105/AJPH.90.11.1765>
- McNamee, C. M. (2004). Using both sides of the brain: experiences that integrate art and talk therapy through scribble drawings. *Journal of the American Art Therapy*, 21(3), 136-142. <https://doi.org/10.1080/07421656.2004.10129495>
- Mcwhinnie, H. J. (1985). Carl Jung and Heinz Werner and implications for foundational studies in art education and art therapy. *The Arts in Psychotherapy*, 12, 5-9. [https://doi.org/10.1016/0197-4556\(85\)90028-0](https://doi.org/10.1016/0197-4556(85)90028-0)
- Murray, C. J. L. & Lopez, A. D. (1996). Evidence-based health policy- lessons from the Global Burden of Disease Study. *Science*, 274, 740-743. <https://doi.org/10.1126/science.274.5288.740>
- Nebes, R. D., Pollock, B. G., Houck, P. R., Butters, M. A., Mulsant, B. H., Zmuda, M. D., & Reynolds, C. F. 3rd. (2003). Persistence of cognitive impairment in geriatric patients following antidepressant treatment: a randomized, double-blind clinical trial with nortriptyline and paroxetine. *Journal of Psychiatric Research*, 37(2), 99-108. [https://doi.org/10.1016/S0022-3956\(02\)00085-7](https://doi.org/10.1016/S0022-3956(02)00085-7)
- Olsson, G. I., Nordstrom, M. L., Arinell, H., & von Knorring, A. L. (1999). Adolescent depression: social network and family climate--a case-control study. *Journal of Child Psychology and Psychiatry and Allied Disciplines*, 40, 227-237. <https://doi.org/10.1111/1469-7610.00436>
- Pelkonen, M., Marttunen, M., & Aro, H. (2003). Risk for depression: a 6-year follow-up of Finnish adolescents. *Journal of Affective Disorders*, 77, 41-51. [https://doi.org/10.1016/S0165-0327\(02\)00098-8](https://doi.org/10.1016/S0165-0327(02)00098-8)
- Prescott, C. A., McArdle, J. J., Hishinuma, E. S., Johnson, R. C., Miyamoto, R. H., Andrade, N. N., Edman, J. L., Makini, G. K., Nahulu, L. B., Yuen, N. Y. C., & Carlton, B. S. (1998). Prediction of major depression and dysthymia from CES-D scores among ethnic minority adolescents. *Journal of the American Academy of Child and Adolescent Psychiatry*, 37, 495-503. <https://doi.org/10.1097/00004583-199805000-00012>
- Radloff, L. S. (1977). The CES-D scale: A self-report depression scale for research in the general population. *Applied Psychological Measurement*, 1, 385-401. <https://doi.org/10.1177/014662167700100306>
- Radloff, L. S. (1991). The use of the Center for Epidemiologic Studies Depression Scale in adolescents and young adults. *Journal of Youth and Adolescence*, 20(2), 149-166. <https://doi.org/10.1007/BF01537606>



- Ruhrmann, S., Kasper, S., Hawellek, B., Martinez, B., Hoflich, G., Nickelsen, T., & Moeller, H. J. (1998). Effects of fluoxetine versus bright light in the treatment of seasonal affective disorder. *Psychological Medicine*, 28, 923-933. <https://doi.org/10.1017/S0033291798006813>
- Schatzberg, A. F., Posener, J. A., DeBattista, C., Kalehzan, B. M., Rothschild, A. J., & Shear, P. K. (2000). Neuropsychological deficits in psychotic versus nonpsychotic major depression and no mental illness. *The American Journal of Psychiatry*, 157(7), 1095-1100. <https://doi.org/10.1176/appi.ajp.157.7.1095>
- Smith, D. J. & Blackwood, D. H. R. (2004). Depression in young adults. *Advances in Psychiatric Treatment*, 10, 4-12. <https://doi.org/10.1192/apt.10.1.4>
- Stamatelos, T., & Mott, D. W. (1983). Learned helplessness in persons with mental retardation: Art as a client-centered treatment modality. *The Arts in Psychotherapy*, 10, 241-249. [https://doi.org/10.1016/0197-4556\(83\)90025-4](https://doi.org/10.1016/0197-4556(83)90025-4)
- Steer, R. A., Ball, R., Ranier, W. F., & Beck, A. T. (1999). Dimensions of the Beck Depression Inventory-II in clinically depressed outpatients. *Journal of Clinical Psychology*, 55(1), 117-128. [https://doi.org/10.1002/\(SICI\)1097-4679\(199901\)55:1<117::AID-JCLP12>3.0.CO;2-A](https://doi.org/10.1002/(SICI)1097-4679(199901)55:1<117::AID-JCLP12>3.0.CO;2-A)
- Sullivan, P. & McCarthy, J. (2009). An experiential account of the psychology of art. *Psychology of Aesthetics, Creativity, and the Arts*, 3(3), 181-187. <https://doi.org/10.1037/a0014292>
- Taft, C. (1997). Color meaning and context: Comparisons of semantic ratings of colors on samples and objects. *Color Research and Application*, 22, 40-50. [https://doi.org/10.1002/\(SICI\)1520-6378\(199702\)22:1<40::AID-COL7>3.0.CO;2-4](https://doi.org/10.1002/(SICI)1520-6378(199702)22:1<40::AID-COL7>3.0.CO;2-4)
- Ulman, E. (1992). Art therapy: Problems of definition. *American Journal of Art Therapy*, 30, 70-74.
- Waslick, B., Schoenholz, D., & Pizarro, R. (2003). Diagnosis and treatment of chronic depression in children and adolescents. *Journal of Psychiatric Practice*, 9(5), 354-366. <https://doi.org/10.1097/00131746-200309000-00004>
- Whooley, M. A., Kiefe, C. I., Chesney, M. A., Markovitz, J. H., Matthews, K., & Hulley, S. B. (2002). Depressive symptoms, unemployment, and loss of income. *Archives Internal Medicine*, 162, 2614-2620. <https://doi.org/10.1001/archinte.162.22.2614>
- Wu, F. G., Chang, E., & Lee, Y. J. (2009). Manifestation of Depressive Tendency in Color Perception and Colors Utilized in Creating a Self-portrait. *Color Research and Application*, 34, 84-92. <https://doi.org/10.1002/col.20465>
- Yang, H. J., Soong, W. T., Kuo, P. H., Chang, H. L., & Chen, W. J. (2004). Using the CES-D in a two-phase survey for depressive disorders among non-referred adolescents in Taipei: A stratum-specific likelihood ratio analysis. *Journal of Affective Disorders*, 82, 419-430.
- Young, K. S. (1998). Internet addiction: the emergence of a new clinical disorder. *Cyber Psychology and Behavior*, 1(3), 237-244. <https://doi.org/10.1089/cpb.1998.1.237>
- Young, K. S. (2004). Internet addiction: A new clinical phenomenon and its consequences. *American Behavioral Scientist*, 48(4), 402-415. <https://doi.org/10.1177/0002764204270278>
- Zambelli, G. C., Clark, E. J., & Hodgson, A. D. J. (1994). The constructive use of ghost imagery in childhood grief. *The Arts in Psychotherapy*, 21, 17-24. [https://doi.org/10.1016/0197-4556\(94\)90033-7](https://doi.org/10.1016/0197-4556(94)90033-7)

<http://www.ejmste.com>



For print copies of this issue or articles please send an e-mail to:

[print@modestum.co.uk](mailto:print@modestum.co.uk)

## Comparison of Science and Engineering Concepts in Next Generation Science Standards with Jordan Science Standards

Ahmad Qablan <sup>1,2\*</sup>

<sup>1</sup> The Hashemite University, Zarqa, JORDAN

<sup>2</sup> The University of Alberta, Edmonton, CANADA

Received 30 January 2018 • Revised 9 March 2018 • Accepted 9 March 2018

### ABSTRACT

The purpose of this Science Standards Content Crosswalk study is to compare the degree of alignment between Next Generation Science Standards (NGSS) and Jordan's science standards in K-8. A team of 5 science educators worked together to review each NGSS standard and decide whether there is a conceptual match for it in current Jordan science standards. Rigorous content analysis and interpretation approach was used to make decisions about matches between both sets of standards. Results revealed significant misalignments between the science learning outcomes identified by NGSS and those of Jordan. Results also showed that, Physical Sciences concepts had the highest percentage (58%) of not addressed concepts in 3-5 grade band followed by Earth and Space Sciences (42%) and Life Sciences concepts (36%). However, the highest percentage of not addressed concepts in grade band 6-8 were Earth and Space Sciences (58%) followed by Physical Sciences (46%) and Life Sciences (36%) concepts. This finding can support projections of the needs for new instructional materials and for subject-specific teachers' professional development. The results also provide a clear direction for the newly established national center for curriculum to revise the national science standards and curricula.

**Keywords:** NGSS, Jordan, alignment, science standards

### INTRODUCTION

Textbooks quality has been correlated directly and indirectly to the success of education reforms and to the enhancement of students' understanding (Abd-El-Khalick, Boujaoude, Duschl, Lederman, Mamlok-Naaman, & Hofstein, 2004; Chambliss & Calfee, 1989; Chiappetta & Fillman, 2007; Koppal & Caldwell, 2004). Rich textbooks are shown to help students better understand the difficult concepts and overcome scientific misconceptions. They also serve as a powerful instrument to raise students' interests in learning science topics and improve their achievements in science. Researchers also consider them a critical component of the educational system that is used to promote specific curriculum vision and type (Clement, 2008; Koppal & Caldwell, 2004). The importance of school science textbooks has been further emphasized by several educators (Aldahmash, Mansour, & Alshamrani, 2016; Mansour 2010; Schmidt, McKnight & Raizen, 1996).

According to the Trends in International Mathematics and Science Studies, teachers tend to spend fifty percent of their time in the class learning from textbooks (Schmidt et al., 1996). This precious time that student spend working with science textbooks necessitate paying serious attention from educators and textbooks designers to offer the best learning experiences to students.

As a response to the importance of continually revise science curricula, Jordan Ministry of Education (MoE) initiated in 2011 a comprehensive project to revise the national science education standards and curricula. According to the MoE, the revised framework of science education and the national science education standards are both comprehensive and comparable to those of international education systems (Mullis, Martin, Goh, & Cotter, 2016). They intend to provide each student with the suitable science content knowledge and procedures that is

#### **Contribution of this paper to the literature**

- This study offers ways to compare science education standards internationally and identify ways to enable students to utilize the metalanguage of both science and education.
- It provides knowledge for both educators and science curriculum designers about the impact of adopting Next Generation Science Standards on advancing students' performance in international benchmarking assessments.
- It demonstrates ways for educators to revise science education standards to help build the capacity of future workforce and contribute in advancing the economic status of countries.

needed for the 21<sup>st</sup> century (UNESCO, 2014). This curricular reform was driven from a need to elevate students' numeracy and literacy levels, which have deteriorated on average in recent years, and address the gap between the curriculum and students' competencies in international assessments. As a result of such huge reform activity, new school curricula have been produced and put into effect as of the 2014/2015 academic year.

### **Reforming Science Curricula in Jordan**

As a result of TIMSS and PISA results over the last few years, national committees were formed by MoE to revise the national science standards and curricula (Royal Hashemite Court, n.d) in order to align the national science standards and curricula with those of international standards. Consequently, new science textbooks were developed that are informed by previously used and released TIMSS and PISA items (Ababneh, Al-Tweissi, & Abulibdeh, 2016). The Curricula and Textbooks Directorate has benefitted from the international studies in two ways. First, by analyzing the assessment frameworks of the international studies to identify any possible mismatch in content between the content domain in the assessment frameworks and the content of the Jordanian science textbooks. Second, by integrating similar TIMSS and PISA assessment questions in the national science textbooks in order to familiarize students with such types of questions.

### **Learning from High Performing Countries**

There are ongoing attempts in Jordan to benefit from the experiences of countries that have performed at high levels in large-scale assessments (Ababneh et al., 2016). The United States of America has recently developed an outstanding document that maps the future trends of science education in the 21<sup>st</sup> century. As an attempt to enhance their students' performance in science and better prepare them for the next generation, the USA produced advanced sets of standards for science education "Next Generation Science Standards (NGSS)". The development of such standards was triggered by many recent calls for improvements in K-12 science education from science and engineering professionals in order to keep the United States competitive in the international arena (NRC, 2012).

In addition to that, the analysis of international science benchmarking in high-performing countries was utilized to inform the standards development process (NRC, 2012). According to NRC, it is hoped that these standards when implemented with fidelity, have the potential to fundamentally alter the landscape of American science education and prepare students for college, careers and life in the 21st century (NRC, 2012).

### **Next Generation Science Standards (NGSS)**

In 2012, the National Research Council (NRC) of the USA National Academy of Sciences authored a Framework for K-12 Science Education: Practices, Crosscutting Concepts and Core Ideas. This document provides the underlying basis for the NGSS, which draw on evidence-based research in science, including research on the ways students learn science effectively (NRC, 2012). The three dimensions of the framework (Science Practices, crosscutting concepts, and disciplinary core ideas) provide the foundation for the NGSS performance expectations, which clarify what students will know and be able to do by the end of each grade or grade band. According to the Framework, the Practices describe behaviors that scientists engage in as they investigate and build models and theories about the natural world and the key set of engineering practices that engineers use as they design and build models and systems (NRC, 2013). The Crosscutting Concepts have application across all domains of science. The Disciplinary Core Ideas are designed to focus on what students should know by the time they graduate from high school. They are based on progressions outlined in the Framework and include the Physical Sciences, Life Sciences, Earth and Space Sciences, and Engineering, Technology, and Application of Science. Engineering and technology are also integrated into all grade levels in the NGSS.

Disciplinary core ideas in NGSS are grouped in three domains: the physical sciences; the life sciences, and the earth and space sciences (NGSS Lead States, 2013).

In life sciences (LS), students are expected to learn content knowledge about the development from (Molecules to Organisms); Structures and Processes, (Ecosystems): Interactions, Energy, and Dynamics, (Heredity): Inheritance and Variation of Traits, and (Biological Evolution): Unity and Diversity.

In Earth and Space Sciences (ESS), students are expected to learn content related to the following topics, Earth's Place in the Universe, Earth's Systems, and Earth and Human Activity.

In the Physical Sciences (PS), students will learn content related to Matter and Its Interactions, Motion and Stability: Forces and Interactions, Energy, and Waves and Their Applications in Technologies for Information Transfer.

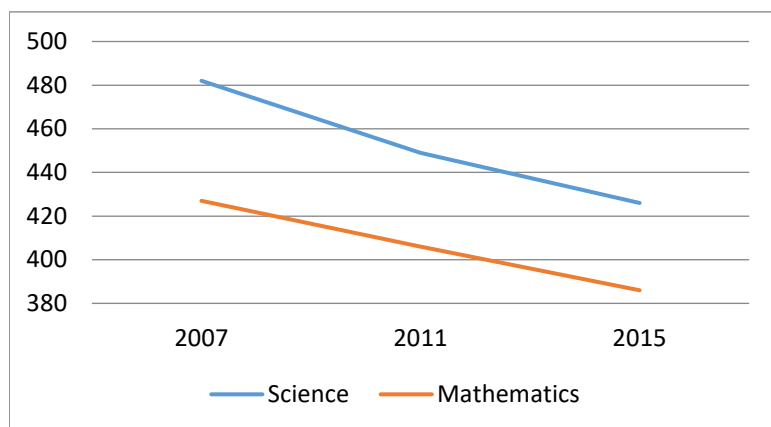
### Jordan Science Standards and learning outcomes in Primary and Lower Secondary Grades

In 2013, a new science curriculum was introduced based on a revised national science content standards. For Grades 1 to 8, there is an integrated curriculum, while in Grades 9 and 10, science is taught as four subjects: biology, chemistry, physics, and earth science. The expectations for students in Grades 1 to 8 are as follows (Mullis et al., 2016):

- **Force and Movement** – Acquire concepts, facts, and basic principles of force and movement, and understand their relationship; use laboratory equipment and instruments to explore concepts, facts, and various scientific measurements; follow safety rules and procedures in the classroom, school, and laboratory; and use oral and written communication and mathematical and physical representations to describe scientific concepts related to force and movement
- **Matter and Energy** – Acquire concepts, facts, and basic principles related to matter and energy; recognize the work of God in the universe and understand that the universe's materials have significant impact on our life; investigate by using the scientific method; use laboratory materials and tools to explore science principles; and follow safety rules and procedures in the laboratory, classroom, school, and home.
- **Organisms and Their Environment** – Show an understanding of the characteristics of living organisms and their needs, life cycles, and relationships with each other and their environment; and demonstrate the knowledge and skills necessary for understanding the nature of the human body and maintaining one's health.
- **Meteorology** – Understand the components and characteristics of the atmosphere and its interaction with Earth's surface Terrestrial Materials – Understand the components and characteristics of land and water systems, their interactions, and human impact on them.
- **Astronomy** – Understand the components of the universe, its characteristics and origin, and the physical laws governing it.
- **Earth's History** – Describe Earth's changes over time.
- **Geological Processes** – Understand geological processes and their role in the formation of topographic features and geological phenomena.
- **Oceans** – Understand that the oceans are a complex, dynamic system in which interactions occur among natural systems, minerals, and weather

### RATIONALE AND PURPOSE OF THE STUDY

Recent results of Jordanian students' performances in both TIMSS and PISA tests showed a serious decline in their academic abilities in both science and mathematics subjects since 2009 (National Center for Human Resources Development, 2013; Qablan, in press) (Figure 1).



**Figure 1.** Jordan Students Academic Performance over years

In addition to that, a recent assessment of the newly released first three grades science textbooks revealed that the revised science textbooks do not provide students with sufficient science content knowledge and do not effectively create a deeper understanding of science content (Queen Rania Foundation, 2015).

Based on these results, several critiques from both educators and public advocates were posed against the reformed Jordanian science standards and curricula. Critiques were mostly revolved around the curricular insufficiency in providing students with the needed content knowledge, These critiques were strongly supported by the recent analysis of Jordan students' performances in the three major dimensions of TIMSS tests; content knowledge, knowledge application, and reasoning and analyzing (Ababneh, Al-Tweissi & Abulibdeh 2016; Qablan, in press) and by the Arab League for Education, Culture, and Science Organization (ALECSO) study that was conducted in 2014 to analyze science students' performances in three Arab countries including Jordan. (ALECSO, 2014).

Thus, this study came to address the need of comparing Jordan reformed science content standards with those of international benchmarks. NGSS science standards have been chosen to act as a reference to compare Jordan's science education standards with those of NGSS (NRC, 2012).

The value of comparing Jordan's science standards with NGSS science standards is that NGSS draw a comprehensive roadmap for future science teaching and learning at both levels, national and international (NRC, 2012). Another valuable addition of the NGSS is the progressions of disciplinary core ideas for students in Kindergarten through high school (NRC 2012). These progressions provide examples of the growth in the sophistication of students' thinking are addressed across grades in the Earth and Space Sciences, Life Sciences and Physical Sciences concepts. These progressions provide also a reference that depicts the content in each grade band.

Moreover, the NGSS provide a totally new dimension to science learning that builds the engineering capacities of students to play the role of engineers while learning science. According to NRC (2012), the rationale for providing students with a foundation in engineering design is based on the idea that engineering design allows students to engage in and solve major societal and environmental challenges and fulfills at the same time the forecasted future needs of more engineers and technicians, who will significantly contribute in resolving the future problems and challenges that will face humanity.

It is worth mentioning that the comparison is mainly focused on the first dimension of NGSS standards which is disciplinary core ideas in physical sciences, life sciences, and Earth and spaces sciences. According to NGSS, disciplinary core ideas are designed to focus on what students should know by the end of each grade or grade band, which satisfies the purpose of this study of determining whether Jordan science standards are providing students with the needed content knowledge that meets the international benchmarks and prepares students to perform well in international tests. However, that is not to neglect the importance of the other two dimensions of NGSS, these two dimensions support building other technical and engineering capacities in students, but they cannot work without reforming the first and making sure that students receive sufficient subject core content knowledge. It is hopeful that once Jordan science content standards are revised and align them to those suggested in NGSS, Jordanian students will have sufficient content and reasoning capacities to help them excel in international tests.

It is also expected that the results of this comparison might help identify the mismatch or grade band delay in addressing the Jordan science standards in order to see if that contribute in the decline of Jordanian students' achievement in international tests. MoE educators might also benefit from the results of this study in revising the national science education standards to help build the capacity of Jordan workforce and therefore contribute in advancing the economic status of the country.



## RESEARCH QUESTION

The NGSS-JOR Standards Content Comparison Study intends to answer the following questions:

1. What are the degrees of match between science concepts in NGSS and Jordan’s science concepts at the same grade?
2. What are the degrees of match between science concepts in NGSS and Jordan’s science concepts with respect to content area?
3. What is the grade band shift in the Jordan’s science standards Framework versus the NGSS?

It is important to note that this study focused only on science content standards because these were viewed to be most informative for MoE leaders concerned about potential changes to curriculum and instructional materials resulting from NGSS comparison. However, the study did not address similarities and differences in the science inquiry practices or performance expectations defined in Jordan’s standards and in NGSS.

To answer these questions, we utilized “The Crosswalk Comparison Tool” developed by Connecticut Department of Education (Connecticut State Department of Education, 2013) to compare between Core Concepts in Next Generation Science Standards for K-8 (NRC, 2013) and concepts in the Jordan Science Curriculum Standards for kindergarten to Grade 8 Science (MoE, 2012).

## METHODOLOGY

### Content Crosswalk Process

This “Science Standards Content Crosswalk” is a process used to compare between Core Concepts in Next Generation Science Standards for K-8 (NRC, 2013) and concepts in Jordan Core Science Curriculum Framework and Curriculum Standards for K-8 Science (Mullis et al., 2016). A scale that describes the degree of match between each comparison (Table 1) was used to rate each comparison category.

**Table 1.** Criteria for rating the degree of match between the NGSS and JOR science standards

Criteria for Match Between Comparison Categories on Standards	Degree of Match Between Standard Categories	Example	
		NGSS	JOR
No identified match	No Match	All organisms have external parts that they use to perform daily functions.	Not Available
Several matches between concepts and terms	Moderate Match	Earth’s orbit and rotation and the orbit of the moon around Earth cause observable patterns.	Moon rotates around the Earth.
Most concepts and terms match	Strong match	Most of Earth’s water is in the ocean and much of Earth’s fresh water is in glaciers or underground.	Water on Earth exists in Ocean, Glaciers, and underground (aquifers)

It is important to note that this study was specifically focused only on science content standards because these were viewed to be most informative for MoE curriculum leaders. The Content crosswalk did not address similarities and differences in the science inquiry practices or performance expectations defined in Jordan science standards and in NGSS.

### Procedures of Standards’ Analysis

An initial examination of each set of standards was conducted. The NGSS were examined using the Disciplinary Core Ideas (NRC, 2012), which are one of the three major dimensions of the NGSS; (Scientific and Engineering Practices, Crosscutting Concepts, and Core Ideas). Jordan’s science standards were also examined using the Disciplines (Physical Sciences, Life Sciences, and Earth and Space Sciences) for grades K-8 as outlined in the Science Grade Level Content Expectations.

A committee of 5 science educators worked together to review each NGSS sub-concept (the bullets found in the NGSS Foundations Boxes) and determine whether there is a conceptual match for it in current Jordan’s science standards. Two members of the committee are specialized in Biology and the other three are specialized in the other three fields of science (Physic, Geology, & Chemistry).

The 5 science educators were trained through an intensive training workshop to pay close attention to the specific concepts included in each content standard. During this workshop, several readings about NGSS and

Jordan’s science standards were provided. Following to that, researchers were trained on how to use Science Standards Content Crosswalk to analyze both the NGSS and Jordan’s science standards using the detailed procedures (See [Figure 2](#)).



**Figure 2.** Science Standards Content Crosswalk Procedure

### Step I. Preparation

1. Choose your Disciplinary Core Idea (DCI): Disciplinary Core Idea (DCI) / Grade Band (You will keep picking the same one each time you go through the search).
2. Choose the NGSS DCI concept you are currently searching for in the Jordan’s science curriculum framework (i.e, K-2 grade band “Living things have different structures and behaviors that allow them to meet their basic needs”).
3. Look through the Content Standards, Supportive Concepts, and either the Grade-Level Concepts (GLCs) for K-8 or the Expected Performances for 9-10. You may need to look at multiple grades above and below. However, do not look through the Enrichment standards.

Structure and Function — How are organisms structured to ensure efficiency and survival?			
GRADE 1			
1.2 — Living things have different structures and behaviors that allow them to meet their basic needs.			
Core Science Curriculum Framework	Grade-Level Concepts <i>Students should understand that...</i>	Grade-Level Expectations <i>Students should be able to...</i>	Assessment
<p>1.2.a. Animals need air, water and food to survive.</p> <p>1.2.b. Plants need air, water and sunlight to survive.</p>	<p><b>GRADE-LEVEL CONCEPT 1.2.a.</b></p> <ol style="list-style-type: none"> <li>1. All living things (organisms) need air, water and food to stay alive and grow; they meet these needs in different ways.</li> <li>2. Most animals move from place to place to find food and water. Some animals have two legs, four legs, six legs or more for moving. Other animals move using fins, wings or by slithering.</li> <li>3. Animals get air in different ways. For example, humans breathe with lungs, while fish breathe with gills.</li> <li>4. Animals get food in different ways. Some animals eat parts of plants and others catch and eat other animals.</li> <li>5. Animals get water in different ways. Some animals have special body parts, such as noses, tongues or beaks that help them get water.</li> <li>6. Fictional animals and plants can have structures and behaviors that are different than real animals and plants.</li> </ol> <p><b>GRADE-LEVEL CONCEPT 1.2.b.</b></p> <ol style="list-style-type: none"> <li>1. Plants absorb sunlight and air through their leaves and water through their roots.</li> <li>2. Plants use sunlight to make food from the air and water they absorb.</li> <li>3. Plants have various leaf shapes and sizes that help them absorb sunlight and air.</li> <li>4. Plant roots grow toward a source of water.</li> <li>5. Plant stems grow toward sunlight.</li> </ol>	<ol style="list-style-type: none"> <li>1. Infer from direct observation and print or electronic information that most animals and plants need water, food and air to stay alive.</li> <li>2. Identify structures and behaviors used by mammals, birds, amphibians, reptiles, fish and insects to move around, breathe and obtain food and water (e.g., legs/wings/fins, gills/lungs, claws/fingers, etc.)</li> <li>3. Sort and classify plants (or plant parts) by observable characteristics (e.g., leaf shape/size, stem or trunk covering, flower or fruit).</li> <li>4. Use senses and simple measuring tools to measure the effects of water and sunlight on plant growth.</li> <li>5. Compare and contrast information about animals and plants found in fiction</li> </ol>	<p>A12. Describe the different ways that animals, including humans, obtain water and food.</p> <p>A13. Describe the different structures plants have for obtaining water and sunlight.</p> <p>A14. Describe the structures that animals, including humans, use to move around.</p>

### Step II. Analysis

1. Identify if there is a strong match (Captures the whole standard), moderate match (captures a piece of the standard), or no match (not available at all).

**Step III: Documentation/Recording Analysis**

1. Identify the level of match:
  - a. Strong Match: List the one standard (and just the standard) that is the strongest match.
  - b. Moderate Match: List the one or two standards (and just the standards) that are moderate matches. If there are more than two, just choose the best two.
  - c. No Match: You will be sent back to the beginning of the survey. Begin again for the next NGSS DCI concept.
2. *Applicable for strong and moderate matches:* Identify where you found evidence of the alignment. Use GLCs for K-8 and expected performances for 9-10. If you only found evidence in the Content Standard or Supportive Concept and not in the GLCs or Expected Performances (See example below):

**GRADE-LEVEL CONCEPT 1.2.a.**

1. All living things (organisms) need air, water and food to stay alive and grow; they meet these needs in different ways.
2. Most animals move from place to place to find food and water. Some animals have two legs, four legs, six legs or more for moving. Other animals move using fins, wings or by slithering.
3. Animals get air in different ways. For example, humans breathe with lungs, while fish breathe with gills.
4. Animals get food in different ways. Some animals eat parts of plants and others catch and eat other animals.
5. Animals get water in different ways. Some animals have special body parts, such as noses, tongues or beaks that help them get water.
6. Fictional animals and plants can have structures and behaviors that are different than real animals and plants.

**GRADE-LEVEL CONCEPT 1.2.b.**

1. Plants absorb sunlight and air through their leaves and water through their roots.
2. Plants use sunlight to make food from the air and water they absorb.
3. Plants have various leaf shapes and sizes that help them absorb sunlight and air.
4. Plant roots grow toward a source of water.
5. Plant stems grow toward sunlight.

Record your result in a table as follows ([Appendix 1](#)).

NGSS Disciplinary Core Idea / Grade Band	Degree of Match in Jordan Science Standards			Evidence of Alignment
	Strong	Moderate	No	

**Step IV: Identification of NGSS in Jordan Grade Level**

1. Identify if there is a grade level (K-8) or grade band shift in the Jordan Framework versus the NGSS. Examples:
  - a. The NGSS DCI concept is in grade 4. You find a match in grade 5 in Jordan’s standards. Choose (JOR is) “at a higher grade/grade band than NGSS.”
  - b. The NGSS DCI concept is in the Middle School grade band. You find a match in grade 4 in JOR. Choose (JOR is) “at a lower grade/grade band than NGSS.”
  - c. The NGSS DCI concept is in the High School grade band. You find a match in grade 9 in JOR. Choose (JOR is) “at the same grade/grade band as NGSS.”
  - d. The NGSS DCI concept is in grade 5. You find matches in grades 3 and 7 in JOR. Choose (JOR is) “at grades/grade bands both above and below NGSS.”

### Step V: Starting New Analysis

Go back to step 1 and begin again for the next NGSS DCI concept.

#### Duration

The duration of comparing both standards lasts for 14 weeks during the second academic semester 2017/2018. Each week, the committee worked together for at least 5 hours to compare both sets of standards. The committee handled each subject alone by projecting the NGSS related standards for each grade band on the board and each of the committee opens the Jordanian standards document. The committee searched to find where each of the NGSS standard located/addressed in Jordanian science standards' document.

#### Validation

After finishing the first cycle of the comparison process, two additional cycles were conducted to validate to check the accuracy of the decisions made in the first cycle regarding the degree of match. The first validation cycle was conducted after four weeks of the first comparison and the second cycle was conducted after three weeks of the first validation cycle. Each of the validation cycles was performed by randomly selecting an NGSS standard and the committee double check their decision whether it is accurate or not. These two validation cycles resulted into no change to the main comparison results.

Once the validation process is completed, the number of matches were counted and percentages for each grade band and core subjects were calculated according to the following equation (# of matches/the total number of NGSS standards) \*100%. Percentages were then used to draw the needed figures.

### RESULTS

#### Match and Mismatch between NGSS and Jordan's Standards at the Same Grade

The greatest percentage (39%) of matched concepts between NGSS concepts and Jordan's national science standards was found in both K-2 and 3-5 grade bands. However, the lowest percentage (18%) of matched concepts was found in 6-8 grade band. Grade band 6-8 showed the highest percentage of moderate match followed by grade band 3-5 with a 16% moderate match and only 6% of moderate match in K-2 grade band (Figure 3).

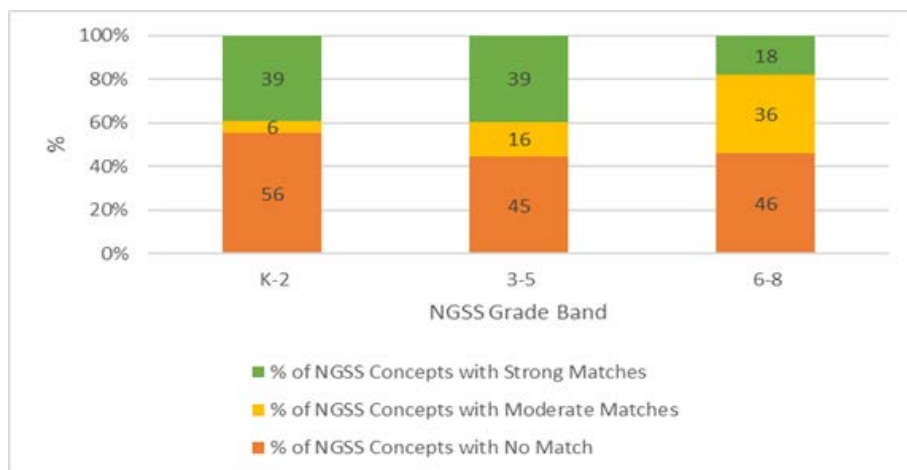
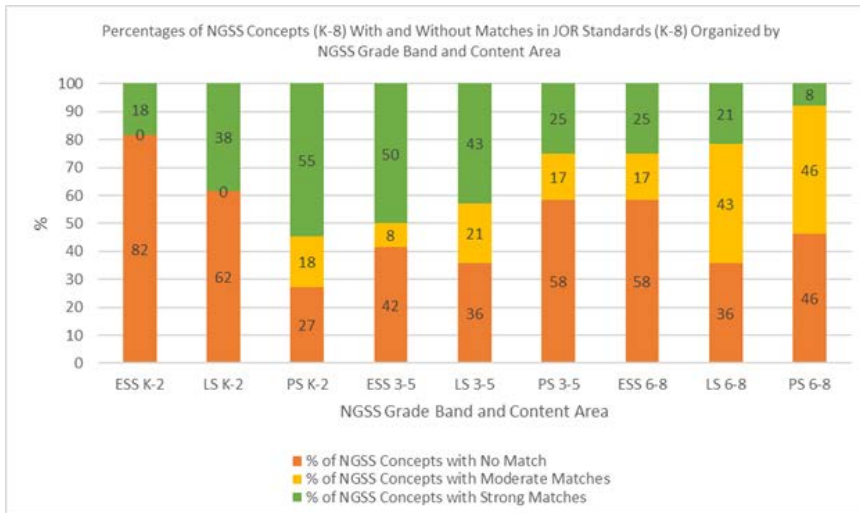


Figure 3. Percentages of NGSS Concepts (K-8) With and Without Matches in JOR Standards (K-8) Organized by NGSS Grade Band

#### Match and Mismatch between NGSS and Jordan's Standards at Each Discipline

The highest percentage (82%) of not addressed science concepts in K-2 grade band in Jordan science standards was found in Earth & Space Sciences (ESS) followed by Life Sciences concepts (LS) with a percentage of (62%) and Physical Sciences (PS) with a percentage of (27%), (Figure 4).



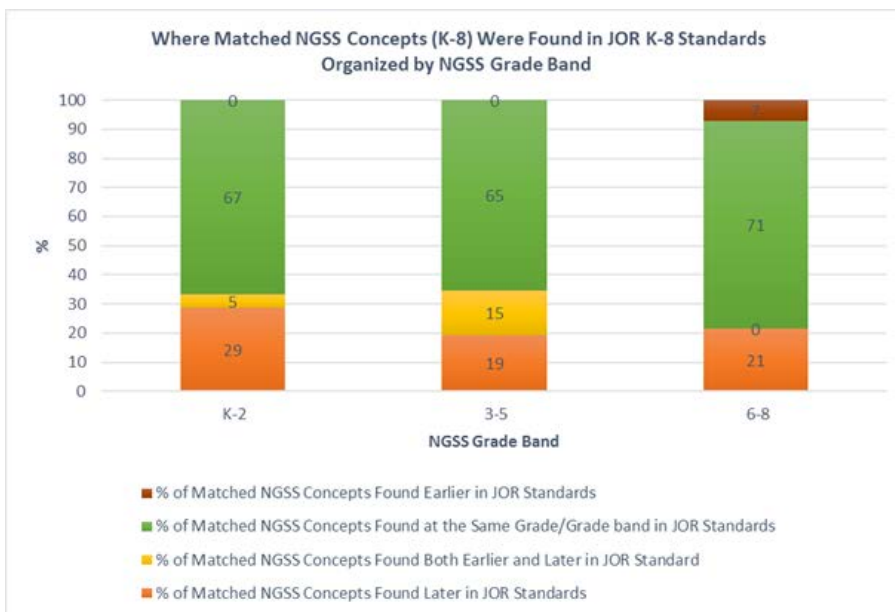
**Figure 4.** Percentages of NGSS Concepts (K-8) With and Without Matches in JOR Standards (K-8) Organized by NGSS Grade Band and Content Area

On the contrary, the highest percentage of not addressed science concepts in 3-5 grade band was found in Physical Sciences (58%) followed by Earth and Spaces Sciences (42%) and Life Sciences (36%).

With respect to 6-8 grade band, more than half of not addressed science concepts was found in Earth and Space Sciences (58%), followed by Physical Sciences (46%) and Life Sciences (36%).

### The Grade Band Shift in Jordan’s Science Standards Framework versus the NGSS

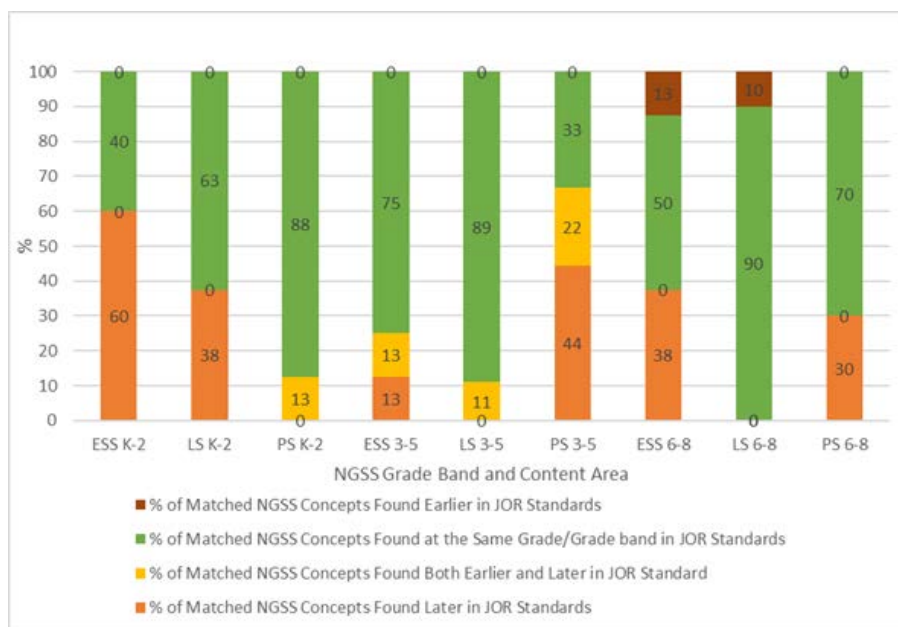
Around 70% of the matched NGSS science concepts in Grades K-8 were found within the same grade bands in both NGSS and Jordan science standards. Twenty-nine percent (29%) of NGSS science concepts of K-2 grade band were found in a later stage in Jordan science standards, however, 21% of NGSS science concepts in grade band 6-8 were found in a later stage in Jordan science standards followed by concepts of 3-6 grade band with a (19%) (Figure 5). However, the highest percentage (15%) of NGSS science concepts of grade band 3-5 were found in both at earlier and at a later stage in Jordan science standards followed by grades K-2. Only 7% of NGSS science concepts found in an earlier stage in Jordan science standards was found in grades 6-8. Appendix 1 demonstrates an availability comparison between NGSS and Jordan science standards across the three grade bands for the three core areas concepts.



**Figure 5.** Where Matched NGSS Concepts (K-8) Were Found in JOR K-8 Standards Organized by NGSS Grade Band



The highest percentage of not addressed NGSS science concepts in grades K-2 that found in later stages in Jordan science standards was found in Earth and Space Sciences concepts (60%) followed by Life Sciences concepts (38%). However, for grades 3-5, the highest percentage of not addressed NGSS science concepts that found in later stages in Jordan science standards was found in Physical Sciences concepts followed by 13% for Earth and Space Sciences concepts. With respect to grades 6-8, the highest percentage of not addressed NGSS science concepts that found in later stages in Jordan science standards was found in Earth and Space Sciences concepts (38%) followed by Physical Sciences concepts (30%) (See Figure 6).



**Figure 6.** Where Matched NGSS Concepts (K-8) Were Found in JOR K-8 Standards Organized by NGSS Grade Band and Content Area

In the same line, the highest percentage of not addressed NGSS science concepts that found in both earlier and later stages in Jordan science standards was found in physical sciences in grades 3-5, followed by Earth and Space sciences (13%) in grades 3-5 and Physical sciences (13%) for grades K-2.

With respect to NGSS science concepts that found in earlier stages in Jordan science standards were found in Earth and Space sciences and Life Sciences for grades 6-8 with percentages of 13% and 10% respectively.

## DISCUSSION

The purpose of this study was to compare the degree of alignment between NGSS science concepts and Jordan's science standards in K-8 grade bands. The results revealed a high percentage of science concepts in NGSS are not addressed in Jordan's science standards in all three grade bands defined by NGSS (NRC, 2013). This result indicates that there are significant misalignments between the science learning outcomes identified by NGSS and those of Jordan.

Results also showed that, Physical Sciences concepts had the highest percentage (58%) of not addressed concepts in 3-5 grade band followed by Earth and Space Sciences (42%) and Life Sciences concepts (36%). However, the highest percentage of not addressed concepts in grade band 6-8 were Earth and Space Sciences (58%) followed by Physical Sciences (46%) and Life Sciences (36%) concepts. These results confirm that Jordan science curricula are not providing students with sufficient subject content in all grade bands. Such misalignment indicates that Jordanian students are not provided with a coherent core science concepts during their school years that help them develop a deep understanding of various science concepts. Such misalignment also provides an explanation of the weak performance of Jordanian students against international benchmarks in the content dimension of international examinations such as TIMSS and PISA. According to IEA (2016), the highest percentage of devoted items in TIMSS 2015 test for 4<sup>th</sup> grade level was for Life Sciences (45%) followed by Physical Science concepts (35%) and Earth and Space Sciences concepts (20%). However, for 8<sup>th</sup> grade TIMSS test, the highest percentage of devoted items was for Life Sciences (35%) followed by Physical Sciences (45%) and Earth and Space Sciences (20%).

These conclusions encourage Jordan's national curriculum department to revise the national science standards in the light of NGSS standards in order to enhance Jordanian students' abilities in science and advance their



performance in international benchmarking assessments. The significance of considering NGSS science standards in revising Jordan national science standards is that the NGSS draws a comprehensive roadmap for future science teaching and learning at both levels, national and international (NRC, 2012). NGSS science concepts were designed based on the content requirements of international tests including TIMSS and are internationally benchmarked against countries whose students typically perform well on the Program for International Student Assessment (PISA) or (TIMSS) (Achieve, 2010) and focuses on a limited number of core ideas in science that build coherently over time throughout K-12 in an effort to foster a greater depth of understanding on a few fundamental concepts within the constraints of the typical school year.

The results of this study also give MoE educators a comprehensive analysis and direction of which and where missed science concepts can be added and or moved. According to the previous analysis, more science contents in all three major domains (Earth and Space Sciences, Life Sciences and Physical Sciences) need to be included in both 3-5 and 6-8 grade bands. The inclusion of the identified learning concepts would also enable Jordanian students to engage in the learning process by understanding and utilizing the metalanguage of both science and education (Mortimer & Scott 2003).

According to the results of this study, most of not addressed science concepts in K-2 grade band were found in a later stage and mostly in 6-8 grade band level. Sixty (60) percent of those delayed science concepts in Jordan science standards were related to Earth and Space Sciences followed by Life Sciences (38%). Similarly, 38% of not addressed science concepts in 6-8 grade band were related to Earth and Space Sciences followed by Physical Sciences (30%) concepts. Such delay in concepts presentation supports the earlier explanation of the weakness in providing Jordanian students with the critical scientific content which also explain the serious decline of Jordanian students' performance in international tests. In this sense, several studies argue the significance of the progressive evolution of children's conceptions of science concepts during the school years (Brook & Driver 1989; Carey, 1985; Holding, 1987; Strauss & Stavy, 1982). For example, Nussbaum (1985) study of the development of children's ideas about the Earth in space revealed a sequence of conceptions; young children ascribe to a flat Earth notion, this is replaced by a notion incorporating a spherical Earth but with an absolute view of 'up and down', later the directions of up and down are construed in terms of movement away from or towards the Earth.

The findings of the study show lack of key science concepts in K-2 grade band and these concepts found in a later stage and mostly in 6-8 grade band level. This can influence negatively the progression of science concepts across three grade needed for developing the students' science concepts progressively. Baxter (1989) identified features in the progression of the science conceptions used by children between ages nine and 16 and indicates how these findings are being used to inform teaching in this domain. Baxter's study suggests that children may progress in their understandings by passing through a series of intermediate notions which, though they may not be correct from a scientific point of view, may however reflect progress in children's understanding. Baxter's study and other similar studies inform the longer-term sequencing of teaching topics and provide information about the range and prevalence of prior ideas that may need to be addressed within a teaching sequence. These studies could also inform science curriculum development across the school years.

Considering these views in designing the progression of science concepts across three grade bands identified in the NGSS is significant to help children understand science concepts at the suitable time. However, delaying the presentation of these concepts would adversely impact students' performance against international benchmarks.

## NGSS INSIGHTS AND VALUES

While the science standards of both Jordan and NGSS overlap in some content areas, there are several values that can be achieved by following NGSS science standards. One of these values is the coherency that exists in NGSS. NGSS science concepts build coherently from grade to grade, while implementing crosscutting concepts that are integrated within core content (NRC, 2013). These crosscutting concepts and namely; Patterns, Cause and effect, Scale, proportion, and quantity, Energy and matter, Structure and function, and Stability and change, connect science concepts and content across all science disciplines and provide students with an enhanced understanding of how different science concepts are connected and utilized to explain different scientific phenomena. The NGSS Framework emphasizes that these concepts need to be explicitly stated for students in order to provide a schema for interrelating knowledge from various fields of science into a coherent and scientific view of the world (NRC, 2012).

Another valuable addition that NGSS provide is the progressions of disciplinary core ideas for students in Kindergarten through high school (NRC, 2012). These progressions provide examples of the growth in the sophistication of students' thinking are addressed across grades in the Earth and Space Sciences, Life Sciences and Physical Sciences concepts. These progressions provide a reference that depicts the content in each grade band.

Moreover, the NGSS provides a totally new dimension to science learning that builds the engineering capacities of students to play the role of engineers while learning science. According to NRC (2012), the rationale for providing

students with a foundation in engineering design is based on the idea that engineering design allows students to engage in and solve major societal and environmental challenges and fulfills at the same time the forecasted future needs of more engineers and technicians, who will significantly contribute in resolving the future problems and challenges that will face humanity.

The engineering perspective that the NGSS provide is missing in Jordan science standards and curricula. It is important not to confuse engineering practices with integrating technological applications in science curricula. Jordan science curricula provide several technological applications for students at the end of some lessons or units. But that does not give students an opportunity to determine the problem and think of resolving it utilizing their understanding of different science concepts. According to the NGSS, the difference between scientific inquiry and engineering design is that the first involves the formulation of a question that can be answered through investigation, while the later involves the formulation of a problem that can be solved through engineering design. By integrating engineering design and thinking into the science education curricula, the NGSS provide students with the tools to engage in solving future environmental and societal problems (NRC, 2012).

## CONCLUSION AND IMPLICATIONS

Findings indicate a significant mismatch between the NGSS and the Jordan's Science Grade Level Content Expectations for K-8. Although this result appears negative, but it is of most significance to Jordan as a country that strives to advance its science education system. The results provide a clear direction for the newly established national center for curricula in Jordan to revise the national science standards and curricula and depart from the traditional approach of designing science curricula to other innovative pathways (i.e., NGSS).

The findings of this study are also useful for identifying the effects of an NGSS adoption on the science curriculum currently taught in Jordanian schools. This knowledge can support projections of the needs for new instructional materials and for subject-specific teachers' professional development.

The NGSS represent the culmination of years of collaboration and effort by several science educators and experts from across the United States (NRC, 2012). The standards were built based on an exhaustive review of the previous science education literature and experiences from around the world to enhance the US students' science learning. Based on the NGSS Framework, the NGSS, when implemented with fidelity, have the potential to fundamentally alter the landscape of American science education and prepare students for college, careers and life in the 21st century (NRC, 2012).

However, it is worth mentioning that adopting the NGSS framework is no small tasks for several reasons. One of these reasons is that the NGSS require several shifts in the way that science is taught (NRC, 2012), which will require engaging students in a series of science and engineering practices that enable them to be prepared to face and resolve the new challenges of the future. Students need to acquire several science concepts and be able to apply their understanding in designing useful tools and technologies to make their life easier. They need to see how different fields of science are connected and used to analyze diverse science phenomena.

To that end, we hope that this study will enlighten science educators in Jordan and the world to advance the way we teach science for students that simulates the recent innovations in international science education. Finally, we hope that revising the national science standards and curricula will help Jordanian students performs better in international tests and regain their leading position in science achievement in the region and the world.

## ACKNOWLEDGEMENT

The author would like to thank the following people (Mohammad Zohdi, Dyala Nofal, Rawan Amroo & Asmaa Mohammad) for their help and support provided during the data collection stage of this study.

## REFERENCES

- Ababneh, E., Al-Tweissi, A., & Abulibdeh, K. (2016). TIMSS and PISA impact – the case of Jordan. *Research Papers in Education*, 31(5), 542–555. <https://doi.org/10.1080/02671522.2016.1225350>
- Abd-El-Khalick, F., Boujaoude, S., Duschl, R., Lederman, N. G., Mamlok-Naaman, R., & Hofstein, A. (2004). Inquiry in science education: International perspectives. *Science Education*, 88, 397–419. <https://doi.org/10.1002/sce.10118>
- Achieve. (2010). *International Science Benchmarking Report: Taking the Lead in Science Education: Forging Next-Generation Science Standards*. Retrieved on April 16 from <https://www.achieve.org/files/InternationalScienceBenchmarkingReport.pdf>

- Aldahmash, A., Mansour, N., & Alshamrani, S., (2016). An Analysis of Activities in Saudi Arabian Middle School Science Textbooks and Workbooks for the Inclusion of Essential Features of Inquiry. *Research in Science Education*, 26(6), 879–900. <https://doi.org/10.1007/s11165-015-9485-7>
- ALECSO. (2014). *Analyzing the results of international TIMSS for the year 2011 in Arab States*. Tunisia.
- Baxter, J. (1989). Children's understanding of familiar astronomical events. *International Journal of Science Education*, 11(Special issue), 502-513. <http://doi.org/10.1080/0950069890110503>
- Brook, A., & Driver, R. (1989). *Progression in Science: The development of pupils' understanding of physical characteristics of air across the age range 5-16 years*. Children's Learning in Science Project, University of Leeds.
- Carey, S. (1985). *Conceptual Change in Childhood*. Massachusetts: MIT Press.
- Chambliss, M. J., & Calfee, R. C. (1989). Designing science textbooks to enhance students' understanding. *Educational Psychologist*, 24(3), 307-322. [https://doi.org/10.1207/s15326985ep2403\\_5](https://doi.org/10.1207/s15326985ep2403_5)
- Chiappetta, E., & Fillman, D. (2007). Analysis of five high school biology textbooks used in the United States for inclusion of the Nature of Science. *International Journal of Science Education*, 29(15), 1847-1868. <https://doi.org/10.1080/09500690601159407>
- Clement, P. (2008). Critical analysis of school science textbooks. *Science Education International*, 19(2), 93- 96.
- Connecticut State Department of Education. (2013). *Science Standards Content Crosswalk Report*. Connecticut, USA.
- Holding, B. (1987). *Investigation of schoolchildren's understanding of the process of dissolving with special reference to the conservation of matter and the development of atomistic ideas* (Unpublished PhD thesis), University of Leeds.
- IEA. (2016). TIMSS 2015 International Results in Mathematics and Science. Boston College. USA.
- Koppal, M., & Caldwell, A. (2004). Meeting the challenge of science literacy: Project 2061 efforts to improve science education. *Cell Biology Education*, 3, 28–30. <https://doi.org/10.1187/cbe.03-10-0016>
- Mansour, N. (2010). The representation of scientific literacy in Egyptian science textbooks. *Journal of Science Education*, 11(2), 91-95.
- Mortimer, E., & Scott, P. (2003). *Making Meaning in secondary science classrooms*. Maidenhead, Philadelphia: Open University Press.
- Mullis, I. V. S., Martin, M. O., Goh, S., & Cotter, K. (Eds.) (2016). *TIMSS 2015 Encyclopedia: Education Policy and Curriculum in Mathematics and Science*. Retrieved from Boston College, TIMSS & PIRLS International Study Center website: <http://timssandpirls.bc.edu/timss2015/encyclopedia/>
- National Center for Human Resources Development. (2013). *Jordan Students Performance on international TIMSS and PISA tests*.
- National Research Council. (2012). *A Framework for K-12 Science Education: Practices, Crosscutting Concepts, and Core Ideas*. Committee on a Conceptual Framework for New K-12 Science Education Standards. Board on Science Education, Division of Behavioral and Social Sciences and Education. Washington, DC: The National Academies Press.
- National Research Council. (2013). *Next Generation Science Standards: For States, By States*. Washington, DC: The National Academies Press. <https://doi.org/10.17226/18290>.
- Nussbaum, J. (1985). The earth as a cosmic body. In R. Driver, E. Guesne, & A. Tiberghien (Eds.), *Children's ideas in science* (pp. 170-192). Milton Keynes, UK: Open University Press.
- Qablan, A. (in press). *Continuous Decline of Jordanian Science Students' Academic Performance in TIMSS: Reasons and Resolutions*. Mutah Lil -Buhuth Wad-dirasat
- Queen Rania Foundation. (2015). *Comparative Curricular Review of the Old and Revised Science Textbooks in Jordan, Grades 1-3* (Unpublished report). Amman: Jordan.
- Royal Hashemite Court. (n.d.). The Education Reform for Knowledge Economy (ERfKE). Retrieved on 31 July, 2016 from [http:// www.kingabdullah.jo/index.php/en\\_US/initiatives/view/id/81.html](http://www.kingabdullah.jo/index.php/en_US/initiatives/view/id/81.html)
- Schmidt, W. H., McKnight, C. C., & Raizen, S. A. (1996). *Splintered vision: An investigation of U.S. science and mathematics education: Executive summary*. Lansing, MI: U.S. National Research Center for the Third International Mathematics and Science Study, Michigan State University.
- Strauss, S., & Stavy, R. (1982). *U-shaped Behavioral Growth*. Academic Press: New York.
- UNESCO. (2014). *Global Citizenship Education: Preparing learners for the challenges of the twenty-first century*. Paris, France.

## APPENDIX 1

### EARTH AND SPACE SCIENCES PROGRESSION

	K-2		3-5		6-8	
	NGSS	JOR	NGSS	JOR	NGSS	JOR
<b>ESS1.A</b> <b>The universe and its stars</b>		NA Available in G4. Part 2 Page77	Stars range greatly in size and distance from Earth, and this can explain their relative brightness.	Available in G3. Part 1 Page72	The solar system is part of the Milky Way, which is one of many billions of galaxies.	G8. Part 2 Page138
<b>ESS1.B</b> <b>Earth and the solar system</b>	Patterns of movement of the sun, moon, and stars as seen from Earth can be observed, described, and predicted.	NA	Earth's orbit and rotation and the orbit of the moon around Earth cause observable patterns.	Moderate G2. Part 1 Page68 G3. Part 1 Page77 G3. Part 1 Page79 G3. Part 1 Page75	The solar system contains many varied objects held together by gravity. Solar system models explain and predict eclipses, lunar phases, and seasons.	G4. Part 2 Page73,74,78 Four seasons and their cause
<b>ESS1.C</b> <b>The history of planet Earth</b>	Some events on Earth occur very quickly; others can occur very slowly.	NA G4. Part 2 Page180 G3. Part 2 Page22,28	Certain features on Earth can be used to order events that have occurred in a landscape.	NA	Rock strata and the fossil record can be used as evidence to organize the relative occurrence of major historical events in Earth's history.	G7. Part 2 Page110 G8. Part 2 Page104
<b>ESS2.A</b> <b>Earth's materials and systems</b>	Wind and water change the shape of the land.	NA G3. Part 2 Page32-37	Four major Earth systems interact. Rainfall helps to shape the land and affects the types of living things found in a region. Water, ice, wind, organisms, and gravity break rocks, soils, and sediments into smaller pieces and move them around.	G4. Part 2 Page88 G4. Part 1 Page22	Energy flows and matter cycles within and among Earth's systems, including the sun and Earth's interior as primary energy sources. Plate tectonics is one result of these processes.	G6. Part 2 P54-56 Fossil energy is addressed.
<b>ESS2.B</b> <b>Plate tectonics and large-scale system interactions</b>	Maps show where things are located. The shapes and kinds of land and water in any area can be mapped.	NA	Earth's physical features occur in patterns, as do earthquakes and volcanoes. Maps can be used to locate features and determine patterns in those events.	NA	Plate tectonics is the unifying theory that explains the movements of rocks at Earth's surface and geologic history. Maps are used to display evidence of plate movement.	G8. Part 2 Page90 G7. Part 2 Page108
<b>ESS2.C</b> <b>The roles of water in Earth's surface processes</b>	Water is found in many types of places and in different forms on Earth.	G1. Part 2 Page 6,8	Most of Earth's water is in the ocean and much of Earth's fresh water is in glaciers or underground.	G3. Part 2 Page10 G5. Part 2 Page 9	Water cycles among land, ocean, and atmosphere and is propelled by sunlight and gravity. Density variations of sea water drive interconnected ocean currents. Water movement causes weathering and erosion, changing landscape features.	NA G9. Part 2 Page14 (Water cycle is mentioned) G10. Part 2. P60 (ocean currents are mentioned) G9. Part 1 Page35 (rain and water movement are mentioned)
<b>ESS2.D</b> <b>Weather and climate</b>	Weather is the combination of sunlight, wind, snow or rain, and temperature in a particular region and time. People record weather patterns over time.	NA	Climate describes patterns of typical weather conditions over different scales and variations. Historical weather patterns can be analyzed.	G5. Part 2 Page21	Complex interactions determine local weather patterns and influence climate, including the role of the ocean.	NA G10. Part 1 Page 9-17. (weather patterns and influence climate)
<b>ESS2.E</b> <b>Biogeology</b>	Plants and animals can change their local environment.	NA	Living things can affect the physical characteristics of their environment.	G4. Part 1 Page 22,24,32	[Content found in LS4.A and LS4.D]	NA
<b>ESS3.A</b> <b>Natural resources</b>	Living things need water, air, and resources from the land, and they live in places that have the things they need. Humans use natural resources for everything they do.	NA	Energy and fuels that humans use are derived from natural sources and their use affects the environment. Some resources are renewable over time, others are not.	NA G6. Part 2 Page 53	Humans depend on Earth's land, ocean, atmosphere, and biosphere for different resources, many of which are limited or not renewable. Resources are distributed unevenly around the planet as a result of past geologic processes.	NA
<b>ESS3.B</b> <b>Natural hazards</b>	In a region some kinds of severe weather are more likely than others. Forecasts allow communities to prepare for severe weather.	NA	A variety of hazards result from natural processes; humans cannot eliminate hazards but can reduce their impacts.	NA	Some natural hazards can be predicted by mapping the history of those natural hazards in a region and understanding related geologic forces.	NA G10. Part 1 Page 66 (earthquake prediction)
<b>ESS3.C</b> <b>Human impacts on Earth systems</b>	Things people do can affect the environment, but they can make choices to reduce their impacts.	G2. Part 2 Page 64	Societal activities have had major effects on land, ocean, atmosphere, and even outer space. Societal activities can also help protect Earth's resources and environments.	G4. Part 1 Page22 G5. Part 2 Page100	Human activities have altered the biosphere, sometimes damaging it, although changes to environments can have different impacts for different living things. Activities and technologies can be engineered to reduce people's impacts on Earth.	NA
<b>ESS3.D</b> <b>Global climate change</b>	NA	LEFT BLANCK	NA	NA	Human activities affect global warming. Decisions to reduce the impact of global warming depend on understanding climate science, engineering capabilities, and social dynamics.	NA

## LIFE SCIENCES PROGRESSION

	K-2		3-5		6-8	
	NGSS	JOR	NGSS	JOR	NGSS	JOR
<b>LS1.A Structure and function</b>	All organisms have external parts that they use to perform daily functions.	Available in G3. Part 1 Page28 G4. Part 1 Page 40	Organisms have both internal and external macroscopic structures that allow for growth, Survival, behavior, and reproduction.	Available in G3. Part 2 Page44 G3. Part 1 Page 28 G5. Part 2 Page 84	All living things are made up of cells. In organisms, cells work together to form tissues and organs that are specialized for particular body functions.	Available in G7. Part 1 Page 40
<b>LS1.B Growth and development of organisms</b>	Parents and offspring often engage in behaviors that help the offspring survive.	Available in G2. Part 1 Page8 G2. Part 2 Page10	Reproduction is essential to every kind of organism. Organisms have unique and diverse life cycles.	Available in G5. Part 1 Page10 G4. Part 2 Page 47	Animals engage in behaviors that increase the odds of reproduction. An organism's growth is affected by both genetic and environmental factors.	Available in G8. Part 2 Page6 G8. Part 2 Page 28
<b>LS1.C Organization for matter and energy flow in organisms</b>	Animals obtain food they need from plants or other animals. Plants need water and light.	Available in G1. Part 2 Page33 G1. Part 2 Page48 G2. Part 2 Page 8	Food provides animals with the materials and energy they need for body repair, growth, warmth, and motion. Plants acquire material for growth chiefly from air, water, and process matter and obtain energy from sunlight, which is used to maintain conditions necessary for survival.	NA	Plants use the energy from light to make sugars through photosynthesis. Within individual organisms, food is broken down through a series of chemical reactions that rearrange molecules and release energy.	Available in G7. Part 1 Page 69
<b>LS1.D Information processing</b>	Animals sense and communicate information and respond to inputs with behaviors that help them grow and survive.	NA Available in G4. Part 1 Page 43,45	Different sense receptors are specialized for particular kinds of information; animals use their perceptions and memories to guide their actions.	Available in G4. Part 1 Page 43	Each sense receptor responds to different inputs, transmitting them as signals that travel along nerve cells to the brain; the signals are then processed in the brain, resulting in immediate behavior or memories.	NA Available in G5. Part 2 Page49 (superficially mentioned)
<b>LS2.A Interdependent relationships in ecosystems</b>	Plants depend on water and light to grow and on animals for pollination or to move their seeds around.	NA	The food of almost any animal can be traced back to plants. Organisms are related in food webs in which some animals eat plants for food and other animals eat the animals that eat plants, while decomposers restore some materials to the soil.	G8. Part 1 Page13 G4.1 Page 9 G5. Part 2 Page83 (Decomposers are not mentioned)	Organisms and populations are dependent on their environmental interactions with both other living things and non-living factors, any of which can limit their growth. Competitive, predatory, and mutually beneficial interactions vary across ecosystems, but the patterns are shared.	G8. Part 1 Page 8 (mutual relationship is not available)
<b>LS2.B Cycles of matter and energy transfer in ecosystems</b>	[Content found in LS1.C and ESS3.A]	NA	Matter cycles between the air and soil and among organisms as they live and die.	NA	The atoms that make up the organisms in an ecosystem are cycled repeatedly between the living and non-living parts of the ecosystem. Food webs model how matter and energy are transferred among producers, consumers, and decomposers as the three groups interact within an ecosystem.	NA
<b>LS2.C Ecosystem dynamics, functioning, and resilience</b>	NA	NA	When the environment changes some organisms survive and reproduce, some move to new locations, some move into the transformed environment, and some die.	Available in G3. Part 2 Page 68	Ecosystem characteristics vary over time. Disruptions to any part of an ecosystem can lead to shifts in all of its populations. The completeness or integrity of an ecosystem's biodiversity is often used as a measure of its health.	NA
<b>LS2.D Social interactions and group behavior</b>	NA	NA	Being part of a group helps animals obtain food, defend themselves, and cope with changes.	NA	NA	NA
<b>LS3.A Inheritance of traits</b>	Young organisms are very much, but not exactly, like their parents and also resemble other organisms of the same kind.	Available in G2. Part 1 Page12 G3. Part 2 Page 50	Different organisms vary in how they look and function because they have different inherited information; the environment also affects the traits that an organism develops.	Mod Available in G5. Part 1 Page38 G5. Part 1 Page 27	Genes chiefly regulate specific proteins, which affect an individual's traits.	Available in G8. Part 1 Page 6 (mutations and gene translation are not available) G7. Part 1 Page 54
<b>LS3.B Variation of traits</b>		Available in G5.1 Page 30		Available in G5.2Page84 G3. Part 2 Page 70-73	In sexual reproduction each parent contributes half the genes acquired by the offspring, resulting in variation between parent and offspring. Genetic information can be altered because of mutations, which may result in beneficial, negative, or no change to proteins in or traits of an organism.	Available in G8. Part 2 Page 6 (Mutations are not mentioned)
<b>LS4.A Evidence of common ancestry and diversity</b>	NA	NA	Some living organisms resemble organisms that once lived on Earth. Fossils provide evidence about the types of organisms and environments that existed long ago.	NA	The fossil record documents the existence, diversity, extinction, and change of many life forms and their environments through Earth's history. The fossil record and comparisons of anatomical similarities between organisms enable the inference of lines of evolutionary descent.	Available in G7. Part 1 Page 114 (comparisons of anatomical similarities between organisms enable the inference of lines of evolutionary descent are not available)

	K-2		3-5		6-8	
	NGSS	JOR	NGSS	JOR	NGSS	JOR
<b>LS4.B Natural selection</b>	NA	<b>NA</b>	Differences in characteristics between individuals of the same species provide advantages in survival and reproduction.	<b>NA</b>	Both natural and artificial selection result from certain traits giving some individuals an advantage in survival and reproduction, leading to predominance of certain traits in a population.	Available in G8. Part 2 Page 38 (Natural selection is not mentioned) G10. Part 1 Page 60 G10. Part 1 Page 44
<b>LSG4.C Adaptation</b>	NA	<b>NA</b> Available in G3. Part 2 Page 70-73	Particular organisms can survive only in particular environments.	Available in G5. Part 2 Page 84	Species can change over time in response to changes in environmental conditions through adaptation by natural selection acting over generations. Traits that support successful survival and reproduction in the new environment become more common.	<b>NA</b>
<b>LS4.D Biodiversity and humans</b>	A range of different organisms lives in different places.	Available in G2. Part 1 Page 7 G2. Part 2 Page 54	Populations of organisms live in a variety of habitats. Change in those habitats affects the organisms living there.	Mod Available in G5. Part 2 Page 94	Changes in biodiversity can influence humans' resources and the ecosystem services they rely on.	Available in G8. Part 1 Page 9-33. (Changes in biodiversity and genetic materials for each species as well as the influence of changes in biodiversity on human resources



PHYSICAL SCIENCES PROGRESSION

		K-2		3-5		6-8	
		NGSS	JOR	NGSS	NGSS	JOR	NGSS
PS1.A Structure of matter (includes PS1.C Nuclear processes)	Matter exists as different substances that have observable different properties. Different properties are suited to different purposes. Objects can be built up from smaller parts.	Available in G2. Part 2 Page16		Matter exists as particles that are too small to see, and so matter is always conserved even if it seems to disappear. Measurements of a variety of observable properties can be used to identify particular materials.	NA	The fact that matter is composed of atoms and molecules can be used to explain the properties of substances, diversity of materials, states of matter, phase changes, and conservation of matter.	Available in G6. Part 1 Page45 G8. Part 1 Page88 G6. Part 1 Page49 G7. Part 1 Page25 G7. Part 1 Page 28
PS1.B Chemical reactions	Heating and cooling of substances cause changes that are sometimes reversible and sometimes not.	Available in G2. Part 2 Page 26-29		Chemical reactions that occur when substances are mixed can be identified by the emergence of substances with different properties; the total mass remains the same.	NA	Reacting substances rearrange to form different molecules, but the number of atoms is conserved. Some reactions release energy and others absorb energy.	Available in G7. Part 1 Page 25 (features of chemical interaction (type of interaction, conservation of mass) are not available.
PS2.A Forces and motion	Pushes and pulls can have different strengths and directions, and can change the speed or direction of an object's motion or start or stop it.	Mod Available in G1. Part 2 Page 62 G3. Part 1 Page 58 G5. Part 1 Page 60 G3. Part 1 Page 54-62		The effect of unbalanced forces on an object results in a change of motion. Patterns of motion can be used to predict future motion. Some forces act through contact; some forces act even when the objects are not in contact. The gravitational force of Earth acting on an object near Earth's surface pulls that object toward the planet's center.	Available in G5. Part 1 Page 56-57	The role of the mass of an object must be qualitatively accounted for in any change of motion due to the application of a force.	NA Available in G9. Part 1 Page 90
PS2.B Types of interactions		NA			Available in G5. Part 1 Page 54	Forces that act at a distance involve fields that can be mapped by their relative strength and effect on an object.	NA Available in G10. Part 2 Page 21
PS2.C Stability and instability in physical systems		NA	Available in G1. Part 2 Page 59	NA	G5. Part 1 Page 56 G5. Part 1 Page 62-63	NA	NA
PS3.A Definitions of energy		NA	Left Blank	Moving objects contain energy. The faster an object moves, the more energy it has. Energy can be moved from place to place by moving objects or through sound, light, or electrical currents. Energy can be converted from one form to another.	NA Available in G6. Part 2 Page 45 G6. Part 1 Page 24 G8. Part 2	Kinetic energy can be distinguished from the various forms of potential energy. Energy changes to and from each type can be tracked through physical or chemical interactions. The relationship between the temperature and the total energy of a system depends on the types, states, and amounts of matter.	Available in G6. Part 2 Page 43 (kinetic energy and factors that influencing it are mentioned)
PS3.B Conservation of energy and energy transfer	[Content found in PS3.D]	Available in G2. Part 1 Page 45			NA Available in G6.2 Page 48		Available in G6. Part 2 Page 47 G7. Part 2 Page 88
PS3.C Relationship between energy and forces	Bigger pushes and pulls cause bigger changes in an object's motion or shape.	NA		When objects collide, contact forces transfer energy so as to change the objects' motions.	NA	When two objects interact, each exerts a force on the other, and these forces can transfer energy between them.	NA
PS3.D Energy in chemical processes and everyday life	Sunlight warms Earth's surface.	NA		Energy can be "produced," "used," or "released" by converting stored energy. Plants capture energy from sunlight, which can later be used as fuel or food.	NA Available in G6. Part 2 Page 42, Page 59, Page 60, Page 66	Sunlight is captured by plants and used in a reaction to produce sugar molecules, which can be reversed by burning those molecules to release energy.	Available in G7. Part 1 Page 70 G7. Part 1 Page 71
PS4.A Wave properties	Sound can make matter vibrate, and vibrating matter can make sound.	Available in G2. Part 2 Page 3		Waves are regular patterns of motion, which can be made in water by disturbing the surface. Waves of the same type can differ in amplitude and wavelength. Waves can make objects move.	Available in G5. Part 2 Page 63 G8. Part 1 Page149 G8. Part 2 Page110	A simple wave model has a repeating pattern with a specific wavelength, frequency, and amplitude, and mechanical waves need a medium through which they are transmitted. This model can explain many phenomena, including sound and light. Waves can transmit energy.	NA Available in G9. Part 1 Page 38-168
PS4.B Electromagnetic radiation	Objects can be seen only when light is available to illuminate them.	Available in G2. Part 1 Page 62		An object can be seen when light reflected from its surface enters our eyes.	Available in G4. Part 1 Page 59 G6. Part 2 P12 G6. Part 2 P21.	The construct of a wave is used to model how light interacts with objects.	Available in G6. Part 2 Page 7-37
PS4.C Information technologies and instrumentation	People use devices to send and receive information.	Available in G1. Part 1 Page 4		Patterns can encode, send, receive, and decode information.	NA Available in G6. Part 2 P30	Waves can be used to transmit digital information. Digitized information is comprised of a pattern of ones and zeros.	Available in G8. Part 1 Page156



<http://www.ejmste.com>



<https://twitter.com/ejmste>



<https://www.facebook.com/ejmste>



<http://modestum.co.uk/>



[publications@modestum.co.uk](mailto:publications@modestum.co.uk)

# Online Model for Teaching and Learning the Specialized Translation

Nataliya Gavrilenko <sup>1\*</sup>

<sup>1</sup> Foreign Languages Department of Engineering Academy, Peoples' Friendship University of Russia, Moscow, RUSSIA

Received 21 March 2017 • Revised 30 August 2017 • Accepted 15 September 2017

## ABSTRACT

The relevance of the research problem is driven by the modern discourse in translation pedagogy. Our understanding of the network enables to find a new way in modelling translation process in the context of modern communications flow, professional groups, databases, interaction technologies for translation companies and clients, project managers and translators etc. The online model for teaching and learning translation is not limited to communication networks. Its main linking node is a social subject – the learner. Such social network's feature as a cell-based structure makes it possible to present theoretical and practical material in the form of modules that include challenges, solution options, necessary internal and external resources, learning activities and ways to check the achievements. The practical value is that the online model for teaching and learning translation will help the students to learn certain modular blocks of the translation model by using structured and unstructured communication channels.

**Keywords:** specialized translation, translational-oriented educational environment, professional competences, translation engine, network communication

## INTRODUCTION

The translator's activity was significantly changed over the past decade (Deng, 2016; Gümüş, 2017; Robinson, Olvera Lobo, & Gutiérrez-Artacho, 2017). He is not asked to provide a paper version or a floppy disk with a translated text on it; he is not asked to send the translation file by e-mail. His activities are in an online environment (Bestué & Orozco, 2016; Choi, Kim, Ullah, & Kang, 2016): translator can get a PDF file with Excel tables and footnotes at the bottom of the page in a Word document. He will have to combine all this information in a translated text and to post it on the website in a specified format (Munday, 2016).

It is pertinent to point out that there is a continuous diversification of special fields (software localization, project management, knowledge management and information management, web content management, the ability to use multimedia and technical equipment, etc.) (Bassnett, 2013; House, 2014; Roh, 2015; Wang, Maeda, & Takahashi, 2014). These changes require new approaches to modelling the translator's activity and preparation. This is particularly evident in the case of specialized translation (Faber, 2012; Shiyab, 2017; Yang, Guo, & Yu, 2016). It is regarded as a "marriage of analog and digital approaches" at the junction of Sciences and Arts (Froeliger, 2013).

One can note that Russian translation studies have been based on the linguistic approach to modeling the translator's activity for a long time (Gavrilenko, 2016; Kujamäki & Footitt, 2016; Venuti, 2012). The gradual shift from analyzing the source text and the target text to identity analysis of the translation subject has greatly expanded the understanding of this professional activity. Cognitive science development entails the proposition of a complex translation model as a verbal-cognitive process (translator's knowledge in combination with the semantic potential of a source text), and its substantiation by an experiment (Chesterman, 2016).

It should be noted that current social network models are typically divided into two main categories: social network formation model and innovation diffusion model (Davydova, Dorozhkin, Fedorov, & Konovalova, 2016). Teaching model for learning specialized translation may be classified as a model of professional training experience

#### **Contribution of this paper to the literature**

- Suggested translation-based educational network allows to concentrate the accumulated knowledge in the field of translation and translation studies, current teaching methods for different interpretation trades and to find partners for joint research and training, to form groups of professional interests to improve translation skills.
- The proposed system of interactive learning allows students to learn other culture by communicating with its representatives, to discuss translation difficulties with native speakers, etc.
- We have consistently correlated the elements of translation competence with determined challenges in order to represent the training modules in a form of an online model. Thus, each training module that we have contains a translational challenge and professional knowledge, skills and traits necessary for its solution.

distribution (Baker & Maier, 2011). In early 2000, we have received a Web 2.0 development, which allowed users to create and distribute different types of content and to form social networks. Social networks became to have not only communication functions, but also the teaching-learning functions (O'Reilly, 2005).

Educational platforms are structures for professional groups to share information and coordinate research and teaching activities, own approaches and other actions, aimed at gaining required competencies. Such platforms in the field of education bring together the representatives of educational institutions that are communicating with each other, exchanging views on education, contributing to a creation of new educational platforms and to a revision of concepts and roles of a tutor and a student (Martín-Blas & Serrano-Fernández, 2009). For example, there are educational platform focused on the teaching and learning foreign languages: Babel (11 languages, over a million users), Busuu (7 languages and more than 9 million users), Livemocha (35 languages and more than 9 million users) (Garcia, 2013).

Currently, there is no single definition for an Educational Platform. This term is often used in relation to online tutorials, video lectures, presentations, tests, etc. (S. Kim, Kim, Park, & Oh, 2016; Padilla-Zea, Medina, Vela, Paderewski, & Collazos, 2017). In this case, we adhere to the definition of online model for teaching and learning translation as an interaction between teachers, translators and students in the context of information technologies, contributing to the creation of appropriate curriculum and an optimal environment for learning, self-study and improvement in the field of translation. Thus, we have a new environment for translator's activity and preparation, which changes the vision of space and time. Presently, teaching and learning translation is impossible out of touch with the community of professional translators, which exists in the context of communications flow, professional groups and sites, databases, interaction technologies for translation companies and clients, project managers and translators (O'Hagan, 2011; Pérez-González & Susam-Saraeva, 2012). These flows should be included in the educational context for preparing translators within a professional context.

## **METHODOLOGICAL FRAMEWORK**

### **Network Analysis and Translator's Activity**

Synergetic approach allows considering both physical and social phenomena, studying the self-organization processes of various systems with linguistic and cultural factors, allowing visualizing their links more clearly while translating (Remkhe, Nefedova, & Gillespie, 2016). Moreover, this approach is regarded as «not just dynamic, but as a self-developing and self-organizing system» (Kushnina & Pylaeva, 2014). Thus, we can classify it as a synergistic system and examine it within the synergetic linguistics.

The network approach, considering modern society as a network society, is one of synergistic approach manifestations. In this case, social structures of society are in the center of network research. Sociologists consider the social network as a union of social terms – social actors and their relationships. The network phenomenon is often explained by the means of a mathematical notion (graph), which may be represented as a number of nodes, connected by edges. The Social Network is a group of nodes: social actors and the relationships between them (social interaction) for resource exchange (Castells, 2003).

One can note that translator's activity is an open dynamic system, which includes many nodes-graphs with edges-links between various elements. For example, the translator himself is linked to the client and to the social environment with a target language. Specialized text is understood based on the translation analysis: communication features in a particular professional environment and social institution, which is difficult to consider out of touch with respective organizations, higher education institutions, traditions, communication ethics etc. (Kim, 2014). Communicative situation, represented by such «nodes» as the «who, where, when, for what purpose, for whom?» is a base for the source text etc. Text translation must be with due account for target language and for features of a particular reader, his occupation, the communicative situation, in which the text will be used.

Each of these elements is related to a number of other determining factors. Online translation model is a combination of these links.

## RESULTS AND DISCUSSION

### Online Model for Teaching and Learning the Specialized Translation

Translation environment for related teachers is not linear. Teacher's professional development depends on various factors: environment, personal beliefs, experiences (teaching and translation), practice etc. (Dogan, Pringle, & Mesa, 2016). These factors rise in creating and implementing the pedagogical teaching models, as well as in the process of consideration, which allows the teacher to structure and generalize the pedagogical situation, to modify and adapt it to different audiences (Bernardini, 2016).

How, who and what should be combined in the educational context? Knowledge and information can be imparted through structured and unstructured channels. Such feature of a network communication as a multi-channel and cell-based structure is a significant factor in creating this context, covering a significant space. This educational platform is not limited to communication networks. Our analysis of the network actors that are able to contribute to translator's preparation in a certain way has allowed identifying four information channels.

*The first channel* - universities, high educational institutions training translators. There are a lot of translation researchers, who accumulate the latest achievements in the field of professional translation and translation studies. These organizations distribute the standards of professional behavior and information about the best material, contributing to a formation of a database involving scientific and practical publications, translation resources, addresses and resumes of different teachers, their service assess terms, etc. Teachers in the field of translation help the students to develop their own styles of learning to achieve the set goals (Biel, 2011).

Currently, the growth of scientific knowledge in these areas is much lower than the increase of researchers. The major part of scientists is required to «hold» the current level of knowledge and education. The necessity to consider translator's activities from the integrative point leads to the process of narrowing the range of issues under consideration. Thus, something important may be missed.

By the way, graduates of translator-training programs in Turkey were asked how well academic training prepared them for professional work. Thus, slightly over half of the respondents (51.7%) agreed that the academic training had prepared them fairly well. 12.4% affirmed that the training prepared them extremely well for professional work, whereas 34.8% of the respondents said that the academic training had provided only basic preparation (Gümüş, 2017).

*The second channel* - knowledge and strategies for organizational and professional solutions can be gained in professional associations, associations of translators, translation-related websites, from professional translators and free-lancers. This channel may involve specific issues on learning translation, online training programs, developed by translation and interpreting companies that are happy to consult those, who are willing to speak about own skills and demonstrate them in practice, etc.

*The third channel* - information can be gained by means of a network involving translation and interpreting companies and organizations that are often using translation services. Such networks are used to find solutions on different problems, provided by clients, consumers and members of translation and interpreting companies. They relay information about innovations in the administrative law, about technological innovations, terminological databases, new translation engines etc., as they are important in translator's activity.

*The fourth channel* - a group of network managers is necessary to serve the network, as they introduce devices and technologies that help to teach and learn specialized translation, as well as provide the assess to available resources and their network security.

### Module-Based Translation System as a Base of an Online Model for Teaching and Learning Translation

Such network's feature as a cell-based structure makes it possible to present the learning material in the form of modules. Module technology is widely used in modern high educational institutions. Experts in the field of module education allocate its various elements: module as a package of learning material, as a training unit, as an information block, as a set of academic disciplines, as a program for professional training, etc. (Gulati, 2008; Zaidan & Callison-Burch, 2011). Module allows preserving the integrity of learning material and its assimilation in structural elements. For example, there is developed a PCTD (personal creative thinking development) system that was implemented in a number of universities in the field of engineering education. It is based on module learning. Module is a part of educational program that synthesizes transdisciplinary issues and problems.

**Table 1.** Translation competencies

Intercultural communicative competence	Readiness and ability (in accordance with the professional speech culture) to understand the statements in foreign language and to re-create them in Russian orally or in written form on the basis of understood meaning
Special competence	Readiness and ability to translate at a high level, possession of appropriate knowledge and skills and the ability to plan further development
Social competence	Level of joint professional activity, specific communication methods, social responsibility for performance etc.
Personal competence	Possession of appropriate personal traits that are important in translation activity

We have analyzed all the elements of translator's professional competency and determined the sequence of system's objectives in order to present a module system for teaching and learning translation.

Competence-based approach is one of important approaches in modern education (Göpferich, 2009). Unfortunately, translation studies have no common approach in considering the actual translation competence and in determining its elements. Literature analysis on translation studies shows the complexity, diversity and double meaning of interpreting this concept, its structure and determined competences. The lack of a common approach in considering the composition of translator's professional competence has determined the theoretical substantiation of determining major translation competencies – generalized competencies that ensure normal human life in society, in our case, in professional translational environment.

Analysis of elements, allocated in the translation competency, allowed us to determine four major competencies (Table 1).

Each of major translator's competence has a number of sub-competences with an open structure that could be changed during further development of important aspects.

It is worth noting that the universally recognized professionally-oriented model of competences was proposed by the EMT expert group (established by the Directorate-General for Translation, European Commission). The following model is regarded as a guideline for Master's level translation programmes and includes translation service provision competence, language competence, intercultural competence, information mining competence, technological competence and thematic competence (Gambier, 2009).

Competence-based approach in teaching translation involves the interaction of personality and activity elements. Any professional activity is carried out in a specific social context; therefore, activity approach to teaching states that translation competence is possible to form gradually in solving translation challenges (Martínez Melis & Hurtado Albir, 2001). For example, task-specific approach is required to use in learning a foreign language with information technologies, as it highlights the macro- and micro-challenges. Solutions for macro-challenges have to be made in a social context by creating a background for interaction with other participants in the educational process, fitting it in the context of a real professional communication. Solutions for micro-tasks are made by carrying out necessary actions. The process of finding these solutions is more independent and private (Grosbois, 2012; J. H. Kim, 2014).

Translator's activity analysis with specialized texts allowed us to present a sequence of challenges. An experienced translator may not face certain challenges. However, this algorithm of professional activities helps to come with learning materials and to propose appropriate methods and techniques for translation competence formation.

Determined challenges were distributed in accordance with the following learning stages:

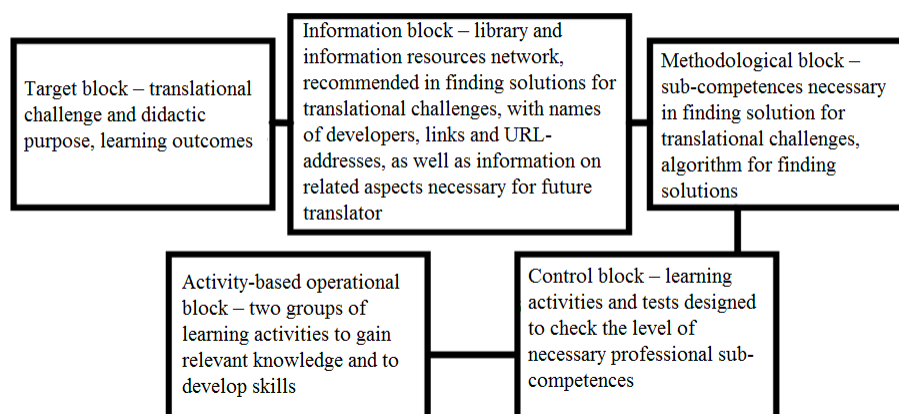
- *professionally-orienting stage* – job hunting, receiving a text for translation from the employer, preparations;
- *analytical stage* – foreign text comprehension and interpretation (information-reference search and translation analysis), translation strategy development;
- *constructing stage* – terminology search, matching and translation on the basis of foreign text;
- *proofreading stage* – correction, editing and turning in a paper for the client.

We have consistently correlated the elements of translation competence with determined challenges in order to represent the training modules in a form of an online model. Thus, the each training module that we have contains a translational challenge and professional knowledge, skills and traits necessary for its solution.

An online model for teaching and learning the specialized translation using information technologies is an example of such a module technology (Figure 1).



Each training module of developed system includes the following elements:



**Figure 1.** Elements of training module for developed translation system

Thus, each training module includes a specific macro-challenge, options for its solution, information resources to solve it, necessary sub-competences, bank of learning activities, options to check the level of translation competence, student-to-student, student-to-translator and student-to-teacher communication abilities. This interactive learning allows students to learn other culture by communicating with its representatives, to discuss translation difficulties with native speakers, etc. Motivation is known to be higher through this communication – everyone can help and get help, such abilities as interaction, teamwork, etc. are developed. In contrast, the ability of independent work is formed due to working with micro-challenges. Furthermore, educational practice within the implementation of models of educational networks proves that the effect of joint activity is always higher than individual efforts due to the increase in the cooperation potential, expansion of relationships, and specific intellectual products (Davydova et al., 2016).

## CONCLUSION

To sum up, traditional linear system for teaching translation (sequential learning of certain topics, techniques and methods of translation, translation instruments) makes it difficult to introduce and to form a full image of professional activity. In a network-learning environment, new theoretical and practical material is presented in modules and distributed throughout the whole course.

In this case, the presentation sequence of learning material in the net is not important. On the contrary, it is how it makes the students to look for the right information, categorize and use it. Such an online model can have many interconnected modules that provide a general idea of translation as a profession. There is special information on how to generate the necessary abilities and skills, how to use different translation engines, to go to different professional translation communities, databases etc. The Network remains a source for gaining knowledge, but the actions of the students are no less important, as well as their ability to gain knowledge independently, to find and to choose the way to generate abilities, etc.

Suggested translation-based educational network allows to concentrate the accumulated knowledge in the field of translation and translation studies, current teaching methods for different interpretation trades and to find partners for joint research and training, to form groups of professional interests to improve translation skills. Translation-based educational network allows regularly enriching and improving the knowledge base and offering new technologies; it is easy to find information by taking into account the diversity of interpretation trades in this fast-growing profession and by selecting the learning strategies that meet the learner's personality.

## REFERENCES

- Baker, M., & Maier, C. (2011). Ethics in interpreter & translator training: Critical perspectives. *The Interpreter and Translator Trainer*, 5(1), 1–14. <https://doi.org/10.1080/13556509.2011.10798809>
- Bassnett, S. (2013). *Translation Studies*. Psychology Press.
- Bernardini, S. (2016). Discovery learning in the language-for-translation classroom: corpora as learning aids. *Cadernos de Tradução*, 36(SPE), 14–35. <https://doi.org/10.5007/2175-7968.2016v36nesp1p14>
- Bestué, C., & Orozco, M. (2016). Online training in legal translation. *Babel*, 62(3), 470–494. <https://doi.org/10.1075/babel.62.3.06bes>

- Biel, Ł. (2011). Training translators or translation service providers? EN 15038: 2006 standard of translation services and its training implications. *The Journal of Specialised Translation*, 16, 61–76.
- Castells, M. (2003). *The Power of Identity: The Information Age: Economy, Society, and Culture Volume II*. Wiley-Blackwell.
- Chesterman, A. (2016). *Memes of translation: The spread of ideas in translation theory*. John Benjamins Publishing Company.
- Choi, S. B., Kim, K., Ullah, S. M. E., & Kang, S.-W. (2016). How transformational leadership facilitates innovative behavior of Korean workers. *Personnel Review*, 45(3), 459–479. <https://doi.org/10.1108/PR-03-2014-0058>
- Davydova, N. N., Dorozhkin, E. M., Fedorov, V. A., & Konovalova, M. E. (2016). Research and educational network: Development management. *Mathematics Education*, 11(7), 2651–2665.
- Deng, M. (2016). Research on the Development Condition of Functional Translation Theory and the Applications on Modern English Translation Practice. *Social Science, Education and Human Science*.
- Dogan, S., Pringle, R., & Mesa, J. (2016). The impacts of professional learning communities on science teachers' knowledge, practice and student learning: a review. *Professional Development in Education*, 42(4), 569–588. <https://doi.org/10.1080/19415257.2015.1065899>
- Faber, P. (2012). A cognitive linguistics view of terminology and specialized language. *Walter de Gruyter*, 20.
- Froeliger, N. (2013). Collection Traductologiques. *Belles Lettres*, 294.
- Gambier, Y. (2009). Competences for professional translators, experts in multilingual and multimedia communication, 11.
- Garcia, I. (2013). Learning a language for free while translating the web. Does duolingo work? *International Journal of English Linguistics*, 3(1), 19. <https://doi.org/10.5539/ijel.v3n1p19>
- Gavrilenko, N. N. (2016). Sender and Recipient Special Discourse Characteristics in Teaching Translation. *International Journal of Environmental and Science Education*, 11(9), 2647–2658.
- Göpferich, S. (2009). Towards a model of translation competence and its acquisition: the longitudinal study TransComp. In *Behind the mind: Methods, models and results in translation process research* (pp. 11–37).
- Grosbois, M. (2012). *Didactics of languages and technologies: From EAO to social networks*. Paris: Presses de l'Université Paris-Sorbonne.
- Gulati, S. (2008). Technology-enhanced learning in developing nations: A review. *The International Review of Research in Open and Distributed Learning*, 9(1).
- Gümüş, V. Y. (2017). Training Translators for the Market in Turkey: What Should We Teach to Future Translators? *International Journal of Comparative Literature and Translation Studies*, 5(1), 1–10.
- House, J. (2014). Translation quality assessment: Past and present. In *Translation: A Multidisciplinary Approach* (pp. 241–264). Palgrave Macmillan UK.
- Kim, J. H. (2014). Foreign Language Learner's Native Culture and Translation. *Information*, 17(12), 6137.
- Kim, S., Kim, J. W., Park, J., & Oh, A. (2016). Elice: An online CS Education Platform to Understand How Students Learn Programming. In *Proceedings of the Third (2016) ACM Conference on Learning Scale* (pp. 225–228). <https://doi.org/10.1145/2876034.2893420>
- Kujamäki, P., & Footitt, H. (2016). Military history and translation studies. *Border Crossings: Translation Studies and Other Disciplines*, 126, 49.
- Kushnina, L. V., & Pylaeva, E. M. (2014). Ecology of translation: contemporary trends and approaches. *Perm University Herald. Russian & Foreign Philology*, (2).
- Martín-Blas, T., & Serrano-Fernández, A. (2009). The role of new technologies in the learning process: Moodle as a teaching tool in Physics. *Computers & Education*, 52(1), 35–44. <https://doi.org/10.1016/j.compedu.2008.06.005>
- Martínez Melis, N., & Hurtado Albir, A. (2001). Assessment in translation studies: Research needs. *Meta: Journal Des traducteurs/Translators' Journal*, 46(2), 272–287. <https://doi.org/10.7202/003624ar>
- Munday, J. (2016). *Introducing Translation Studies: Theories and Applications*. Routledge.
- O'Hagan, M. (2011). Community Translation: Translation as a social activity and its possible consequences in the advent of Web 2.0 and beyond. *Linguistica Antverpiensia, New Series–Themes in Translation Studies*, (10).
- O'Reilly, T. (2005). *What Is Web 2.0*.
- Padilla-Zea, N., Medina, N. M., Vela, F. L. G., Paderewski, P., & Collazos, C. A. (2017). PLAGER-VG: platform for managing educational multiplayer video games. *Multimedia Tools and Applications*, 1–38.

- 
- Pérez-González, L., & Susam-Saraeva, Ş. (2012). Non-professionals translating and interpreting: Participatory and engaged perspectives. *The Translator*, 18(2), 149–165. <https://doi.org/10.1080/13556509.2012.10799506>
- Remkhe, I. N., Nefedova, L. A., & Gillespie, D. C. (2016). From Function to System: Advances in Choosing a Matrix Structure of the Translation Process. *Russian Journal of Linguistics*, 20(3), 230–242.
- Robinson, B. J., Olvera Lobo, M. D., & Gutiérrez-Artacho, J. (2017). The professional approach to translator training revisited.
- Roh, S. Z. (2015). Structural Relationships of Adult e-Learners' Teaching Presence, Self-Efficacy toward e-Learning, and Learning Satisfaction: Focused on the Mediating Effect of Learning Presence and Learning Flow. *Information*, 18(6), 2759.
- Shiyab, S. M. (2017). Specialized Translation: Shedding the "Non-Literary" Tag. *Babel*, 62(4), 686–687. <https://doi.org/10.1075/babel.62.4.10shi>
- Venuti, L. (2012). *The translation studies reader*. Routledge.
- Wang, M., Maeda, Y., & Takahashi, Y. (2014). Teaching Assistant System used Eye Tracking Device Based on Gaze Estimation by Neural Network and Intention Recognition by Fuzzy Inference. *Information*, 17, 4661–4676.
- Yang, X., Guo, X., & Yu, S. (2016). Effects of cooperative translation on Chinese EFL student levels of interest and self-efficacy in specialized English translation. *Computer Assisted Language Learning*, 29(3), 477–493. <https://doi.org/10.1080/09588221.2014.991794>
- Zaidan, O. F., & Callison-Burch, C. (2011). Crowdsourcing translation: Professional quality from non-professionals. In *Proceedings of the 49th Annual Meeting of the Association for Computational Linguistics: Human Language Technologies-Volume 1* (pp. 1220–1229).

**<http://www.ejmste.com>**



For print copies of this issue or articles please send an e-mail to:

[print@modestum.co.uk](mailto:print@modestum.co.uk)

# Chinese College English Teachers' Ability to Develop Students' Informationized Learning in the Era of Big Data: Status and Suggestions

Guo-Rong Shen <sup>1\*</sup>

<sup>1</sup> School of Foreign Languages, Henan University of Technology, Zhengzhou, Henan, CHINA

Received 28 February 2018 • Revised 11 April 2018 • Accepted 12 April 2018

## ABSTRACT

College English teachers should vigorously promote the integration of the latest information technology and curriculum teaching. The application of modern information technology to college English teaching has not only modernized, diversified and facilitated the teaching methods, but also changed the teaching concepts, teaching contents and teaching methods. The ultimate goal of integration is to promote the development of students' informationized learning ability. Therefore, the purpose of this paper is to investigate college English teachers' development of students' informationized learning ability in the era of big data, and explore a motivation system that motivates teachers to develop students' informationized learning ability. A questionnaire survey was conducted in three universities with different degrees of informationization. It is found that the universities do not make enough investments to accommodate the future development needs of smart education; the teachers show weak ability to use the software, do not master the use of software and fail to implement the design, development and the nation has not issued institutional policies and offered enough time and opportunities for teachers' training. It is advised that the development of teachers' informationized teaching ability is to strike a balance between promoting the development of teachers' teaching ability and enhancing the development of students' learning ability; China should make dynamic adjustments to the assessment and monitoring system of teachers' informationized teaching ability and China should keep pace with the times in terms of investment in education teaching cause, and gradually improve its policy supports and incentives.

**Keywords:** college English teachers, ability to use information tools, motivation system

## INTRODUCTION

Undoubtedly, the wide application of modern information technology (especially the Internet and multimedia technology) injects infinite fresh power into college English teaching. The new teaching platform definitely provides college students with the convenience to develop their comprehensive English abilities. In the traditional teaching concept, the teachers assume the responsibility of "propagating the doctrine, imparting professional knowledge and resolving doubts", so they are absolute authority of knowledge (Mei, 2011, pp. 165-170). However, in the new teaching model, the teachers are responsible for designing and developing the learning process and resources, guiding and promoting the students' learning process, organizing and coordinating the students' collaborative learning, monitoring and assessing the students' learning process, so they are no longer the "center" of the class. With the continuous development of informationized learning, the education service includes not only schools, but also social institutions and various networks that can provide education services. As a result, both on-campus and off-campus learning services are available, realizing an integrated on-campus and off-campus as well as the online and offline education service experience. What's more, the convenient information services

#### Contribution of this paper to the literature

- This paper contributes to increasing teachers' motivation to study teaching English with IT and know the present situation of teachers' ability to develop students' informationized learning in the Era of Big Data.
- The paper provides instructions and suggestions to enhance College English Teachers' ability to develop students' informationized learning in the Era of Big Data.
- By considering the researches made by scholars as mentioned in the literature review, this study develops a more comprehensive framework to analyze and evaluate teachers' ability to develop students' informationized learning in the Era of Big Data.

have prompted the reconstruction of foreign language teaching and learning model. The independent learning, U-Learning, social learning, game-based learning, inquiry-based learning under the simulation environment, remote real-time collaborative learning and social interactive learning will become the main forms of student learning in the future information society (Fang & Chen, 2018, pp. 57-62).

As the information society puts forward new requirements on the teaching ability of teachers, the students' learning abilities also change accordingly. The relevant previous studies (Ran, 2014; Ran & Yang, 2014; Shen & Li, 2017; Wang, 2009) focus on the improvement of teachers' effective teaching ability as well as the promotion of teachers' professional development in the information environment. At present, much attention is paid to the development of students' abilities. This phenomenon thus indicates that the improvement of teachers' teaching ability is to promote the development of students' learning ability. This trend of change is proved by other countries' requirements on the teachers' technical competence standards. Furthermore, it is believed that the development of teachers' informationized teaching ability aims at promoting the development of informationized learning ability of students who adopt different learning styles and strategies. In other words, although this study focuses on the development of teachers' informationized teaching ability, the purpose of this ability is to promote the development of students' informationized learning ability. A questionnaire survey was conducted in three universities with different degrees of informationization to investigate college English teachers' development of students' informationized learning ability in the era of big data, and explore a motivation system that motivates teachers to develop students' informationized learning ability.

## LITERATURE REVIEW

Wang (2012, pp. 45-53) argued that "informationized teaching ability was divided into six sub-abilities: the informationized teaching transfer ability, informationized teaching integration ability, the informationized teaching communication ability, the informationized teaching assessment ability, the informationized collaborative teaching ability and the ability to promote students' informationized learning". Zhao and Guo (2010, pp. 28-31) emphasized that "the informationized teaching ability referred to the ability that the teachers took advantage of the information and communication technologies, promoted the students to transform the learning methods, and enhanced students' comprehensive utilization competence over learning resources and the learning environment in the information literacy process by adopting the teaching design, teaching implementation, teaching assessment and other methods." According to Wang, "the informationized teaching aimed at making full use of information resources to promote the students' development and to efficiently complete the teaching tasks." He classified the teachers' informationized teaching ability into six aspects - the informationized teaching transfer ability, informationized teaching integration ability, the informationized teaching communication ability, the informationized teaching assessment ability, the informationized collaborative teaching ability, and the ability to promote students' informationized learning (Wang, 2009, pp. 106-111).

The TSACK (Technological Strategic and Content Knowledge) framework explains the requirements over the abilities and knowledge of teachers who are in an implicit position. The TSACK framework focuses on teachers but ignores students. Ruan (2014, pp. 20-26) held that they must grasp the subject knowledge, learning methods or tactical knowledge as well as the information technology knowledge in learning. TSACK refers to Technological Knowledge, Content Knowledge and Strategic Knowledge (See [Figure 1](#)). The vigorous development of "research-based learning", "inquiry-based learning", "task-based learning", "project-based learning", "action learning", "independent learning" and the "flipped classroom" are to improve the students' knowledge and ability. In addition, the TSACK framework can be used to explain the ability and knowledge of students who are in an explicit position, and it is the expansion and complement of the TSACK framework.



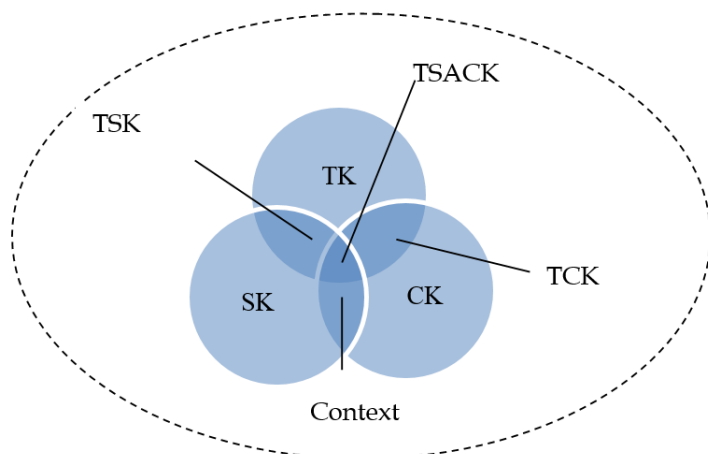


Figure 1. TSACK Framework Diagram

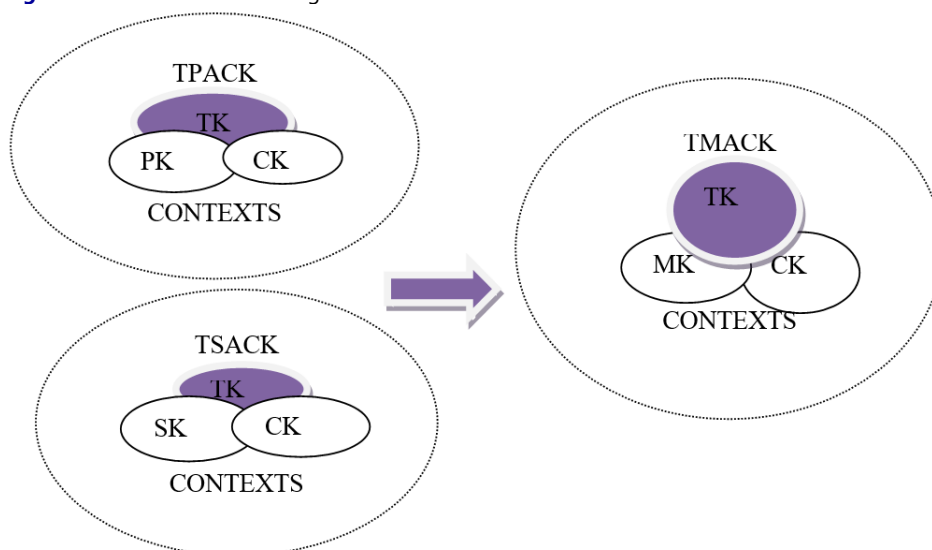
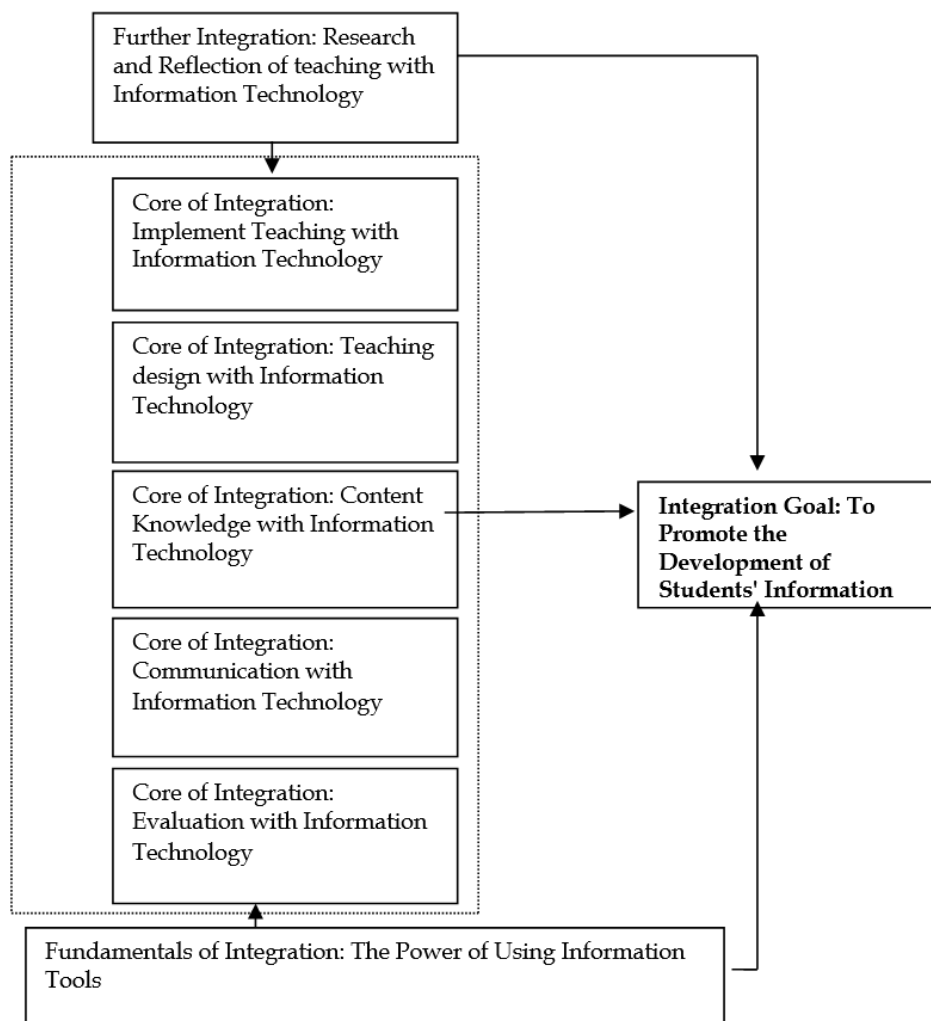


Figure 2. TMACK (Technological Methodological and Content Knowledge) Framework Diagram

Fundamentally, both the ability of teaching methods (teachers) and strategy for learning methods (students) fall into the category of methodology. They are an advanced thinking of asking, analyzing and solving questions, that is, methodological knowledge. To sum up, the ultimate goal of educational activities is to achieve common development of teachers and students. The knowledge and ability structure required in this process is TMACK (Technological, Methodological and Content Knowledge), which can be expressed as:  $TMACK = TPACK + TSACK$  (as shown in Figure 2).

Shen and Li (2017, pp. 55) argued that the prerequisite ability for teachers to achieve the informationized teaching was the ability to realize the high integration between informationized technology and the college English teaching, including the informationized teaching design ability, the English content knowledge ability, the ability to use information tools for implementation of teaching, the informationized communication ability, the informationized assessment ability and the informationized teaching, research and reflection ability. The ability to use information technology tools was the foundation and premise of integration. The teaching research and reflection of teachers may develop and enhance the teachers' integration ability. The ultimate goal of integration was to promote the development of students' informationized learning ability. Besides, the college English teachers should facilitate their students to develop the following abilities: (1) online independent learning ability; (2) self-control ability; (3) information acquisition ability; (4) information evaluation ability; (5) information management ability; (6) information processing ability; and (7) communication and collaboration ability (as shown in Figure 3).



**Figure 3.** Schematic Diagram for College English Teachers' Informationized Teaching Ability

## RESEARCH DESIGN

To learn more about the current situation of college English teachers' informationized teaching ability, the author designed *the Questionnaires on College English Teachers' Ability to Use Information Tools*. The Likert scale was used in all questionnaires and consisted of: 1 = "Strongly disagree", 2 = "Disagree", 3 = "Neither agree nor disagree", 4 = "Agree", 5 = "Strongly agree".

In the first half of March 2015, the author made an online survey, when a total of 135 questionnaires were returned. Of these, 131 valid questionnaires were recollected. The success rate was 97%. Using SPSS software, the recovered data were processed, the reliability of the questionnaire was examined, and the questionnaire items were analyzed.

In order to examine whether the specific content of the questionnaire survey has discriminatory ability, that is, whether the questionnaire project has discriminating power, the author used the independent sample T-test and related analysis methods to analyze the questionnaire. If the correlation coefficient is equal to or greater than 0.30, and the significance level is reached ( $p \leq 0.05$ ), it indicates that the internal consistency of the questionnaire is high or the questionnaire item has a good differentiation (Qin, 2009, pp. 209). After summing up and analyzing the scores of all the items (34 items) of the 131 student questionnaires, it was found that only one item's correlation coefficient was less than 0.30, and the requirement for the significance level ( $p \leq 0.05$ ) was not reached. As far as possible to ensure that the questionnaire has a good degree of differentiation, the author deleted this item.

Reliability refers to the stability of the questionnaire measurement results. Reliability can be analyzed by the external reliability test and the intrinsic reliability test. Since the study was conducted via online testing, the questionnaire could not be re-tested. Therefore, instead of using the external reliability test, the author used the

Cronbach's alpha coefficient to examine the reliability of the questionnaire in the intrinsic reliability test method. According to Qin (2009, pp. 220-221), the generally accepted Cronbach's alpha reliability coefficient should not be lower than 0.70; and using the SPSS 19.0 statistics package, the Cronbach's alpha coefficient of this questionnaire was 0.931, indicating that the internal consistency of the questionnaire was high.

After adjustment, the questionnaire consists of 33 items.

In May 2015, the author conducted a questionnaire survey on three universities: A, B and C. A total of 450 students and 160 college English teachers participated in the survey. The author entrusted some teachers from the three universities to hand out the questionnaires. He required the teachers to inform students of the purpose, significance and matters needing attention of this survey in advance, and required the teachers to collect the questionnaires after being filled out. A total of 450 questionnaires were handed out to students, with 420 questionnaires recovered. Through careful observation and analysis, 33 invalid questionnaires (the same answers were given for all questions or the questionnaires were only filled out partially) were removed, and 387 effective questionnaires were collected as the data source for the survey. Afterwards, all questionnaires were entered into the SPSS 19.0 software for future use after careful sorting.

## DATA ANALYSIS AND DISCUSSION

### Analysis of Questionnaire Data

The foreign language learners dock with "Internet +" in the big data era. In the face of massive learning resources, the learning methods have undergone tremendous changes, from the traditional models to e-learning, mobile learning, U-learning, smart learning and deep learning. These new learning methods provide a solid platform and basis for human information exchange and innovation development. However, these big data-based learning methods have not been adequately reflected in China's foreign language teaching. The traditional class teaching is still the popular. For example, the students accept teaching with the same mode, contents and progress, and they are subject to limited choice and utilization of technologies and resources. Therefore, it is essential to reconstruct a new appropriate and effective paradigm of foreign language teaching by relying on "Internet +", so as to make China's foreign language teaching keep pace with the big data era (Chen, 2017, pp. 5). As the informationized learning methods continue to expand, the education service providers include not only schools, but also social institutions and various networks. As a result, both on-campus and off-campus learning services are available, realizing an integrated on-campus and off-campus as well as the online and offline education service experience.

**Table 1.** Questionnaires on College English Teachers' Ability to Use Information Tools in Three Universities

Questions	Three Universities	
	Mean	Standard Deviation
1. Our hardware facilities can meet our informationized learning requirements.	4.05	.718
2. I like the English programs regularly broadcasted on the campus radio.	4.63	.651
3. I like to use the campus Wi-Fi to assist in English learning.	4.53	.672
4. My English teacher has good computer skills.	3.36	.751
5. I like our teachers to carry out college English teaching by using computer, internet and other informationized tools.	4.36	.542

According to **Table 1**, Q1 - "Our hardware facilities can meet our informationized learning requirements" (M=4.05) indicates that, students from the three universities are basically satisfied with the hardware conditions. As the computer, multimedia and other information technologies enter the campuses, the universities have invested heavily in the configuration of English teaching facilities, so the hardware facilities continue to be improved. The universities regularly broadcast English programs (Q2, M=4.63), and the students use the campus Wi-Fi to assist in English learning (Q3, M=4.53). The teachers often use computers, networks and other informationized tools for college English teaching (Q5, M=4.36), but the students think that the English teachers' computer skills need to be improved (Q4, M=3.36). Consequently, the universities shall continue to increase investment, so as to accommodate the future development needs of smart education: online decision-making, learning analysis and data mining.

The ability to use information tools refers to the ability of using teaching equipment, teaching software, network and other information tools in college English teaching (Vance & Carlson, 2013, pp. 35-43). For teachers who undertake teaching tasks, certain technical skills and ability is one of the teaching abilities that the teachers must possess. This requires teachers to complete classroom tasks by making use of simple teaching software in multimedia devices. According to **Table 2**, Q6 - "When teaching college English, my teacher can freely operate the multimedia teaching platform devices such as the computer, projector and video presenter, and other teaching

**Table 2.** Questionnaires on College English Teachers' Ability to Use Information Tools in Three Universities

Questions	Three Universities	
	Mean	Standard Deviation
6. When teaching college English, my teacher can freely operate the multimedia teaching platform devices such as the computer, projector and video presenter, and other teaching equipment such as the camera.	4.02	.818
7. When teaching college English, my teacher can skillfully use office software (such as word, Excel, etc.).	4.03	.791
8. When teaching college English, my teacher can skillfully use texts, pictures, animation, video and other media to carry out teaching.	3.53	.773
9. When teaching college English, my teacher can use the network platforms (such as QQ and MicroBlog) to publish discussion questions to discuss with us.	4.06	.781

**Table 3.** Questions on Analysis of College English Teachers' Informationized Content Knowledge Ability

Questions	Three Universities	
	Mean	Standard Deviation
10. I once saw in the courseware the data and resources about English learning collected by my English teacher with a camera.	3.53	.980
11. My English teacher can vividly present college English learning contents by using images, video, animation and other information technologies.	3.62	.935
12. My English teacher can use the image processing software and video editing software to process the collected data and resources according to the needs of teaching, so that we can use them in class.	3.78	.792
13. My English teacher can present simple and clear PPT with rich contents and scientific reasonable forms of expression.	3.73	.870
14. My English teacher allows us to copy his/her digital college English teaching resources.	3.90	.812

equipment such as the camera" (M=4.02) indicates that, through the training conducted by factories and the universities, the college English teachers can freely operate the multimedia teaching platform devices such as the computer, projector and video presenter, and other teaching equipment such as the camera. Q9 - "When teaching college English, my teacher can use the network platforms (such as QQ and MicroBlog) to publish discussion questions to discuss with us" (Q9, M=4.06) implies that, the teachers can timely interact with students by using the network platforms (such as QQ and MicroBlog). The teaching in the information society is not only the imparting of knowledge and skills, but also the development of students' learning ability and the growth of students. Therefore, it is necessary for teachers and students to interact effectively. The teaching methods in the information society embody the characteristics of selection and interaction. Correspondingly, the students' learning methods are also inclined to cooperation, dialogues, exchanges, inquiries and similar practices. With the popularization of MicroBlog, more and more teachers begin to introduce MicroBlog to the field of teaching practice, making it a tool for students' learning and network interaction between students and teachers. The application of MicroBlog to college English teaching may facilitate students to carry out independent learning. However, the teachers show weak ability to use the software, do not master the use of software (such as office software, image processing software, animation software, and video-audio editing software), and fail to implement the design, development, processing and rendering of college English teaching resources with these software (Chen, 2017, pp. 3-16).

According to **Table 3**, Q10 - "I saw in the courseware the data and resources about English learning collected by my English teacher with a camera" (M=3.53) shows that, most teachers can use the information technologies of images, videos and animations to express English knowledge, transmit information and promote learners' understanding and meaning construction according to the modern teaching concept and teaching needs. Q11 - "My English teacher can vividly present college English learning contents by using images, video, animation and other information technologies" (M=3.62, M=3.73) suggests that, most teachers can use the information technology tools such as cameras to record the data and resources required for English teaching, and process the data and resources by using the image processing software and video editing software according to the needs of teaching, yet the teachers show weaknesses. Q12 - "My English teacher can use the image processing software and video editing software to process the collected data and resources according to the needs of teaching, so that we can use them in class" (M=3.78) indicates that, most teachers can use the computer, network hard drive, web favorites and other information technology tools to classify and save digital college English teaching resources. Q14 - "My English teacher allows us to copy his/her digital college English teaching resources" (M=3.90) shows that, most teachers can use the information technology tools (such as online survey platform) to evaluate the relevant digital college English teaching resources, but they fail to give full evaluation.

With the continuous development of the information era, the classroom teaching also proposes new requirements for teachers' roles. On the one hand, the teachers should master various common information tools for assistance in teaching. On the other hand, the teachers are required to transmit these tools with students, mobilize their enthusiasm to participate in classroom activities, and play the main role of students. The ability to manage teaching links by using information tools refers to the ability to manage all links of college English teaching implementation by using information tools so as to achieve the teaching objectives. Examples include the ability to stimulate and maintain students' learning motivation, as well as the ability to respond to emergencies. As can be seen from **Table 4**, Q16 - "My English teacher stimulates our motivation to learn in the informationized teaching" (M=3.90) and Q17 - "My English teacher can use the network communication technologies (E-mail, QQ, MNS, etc.) and guides us to learn collaboratively" (M=3.59) show that, the teachers have developed the ability to stimulate and maintain students' learning motivation. Q18 - "My English teacher can monitor our online learning activities and learning process and guide us to resolve problems by using the information technology tools" (M=3.60) indicates that, most teachers have the ability to monitor the students' online learning activities and learning processes and give timely instruction to students' problem-resolving ability by using the information technology tools, yet there is room for improvement. Q20 - "My English teacher sends us the learning materials collected online before class" (M=3.33), Q21 - "My English teacher encourages us to report in class and share relevant materials searched on the Internet" (M=3.59), and Q23 - "Before class, my English teacher sends us the courseware created through the software (such as Authorware, PowerPoint and FLASH)" (M=3.48) demonstrate that, most teachers have the ability to share and regenerate the teaching contents, and provide students with digital college English teaching resources via the Internet. Q22 - "My English teacher spends a third of the time in the class to explain and spends the rest of the time to guide us to identify problems, and help us find an effective way to resolve the problems through discussions and exchanges" suggests that, most teachers gradually get rid of the traditional teaching concept, establish the informationized teaching concept, and apply it in practice. Q24 - "In the college English informationized teaching process, the teacher interacts with classmates, organizes, manages and coordinates our study" (M=3.46) shows that, in the process of college English teaching, most teachers use network chat rooms, audio-visual conference and other information technologies to monitor the online learning, answer questions, and give prompt feedback. Q25 - "My English teacher assesses not only our knowledge and skills but also our development of practical ability and emotional development in the informationized learning" (M=3.68) indicates that, the universities have developed the online teaching evaluation management mechanism, and some teachers may receive timely feedback through the Internet. Q26 - "My English teacher tracks our learning process, collects data, mines data, and automatically adjusts teaching strategies" (M=3.68) states suggests that, the English teacher tracks our learning process, collects data, conducts data mining, and adjusts teaching strategies accordingly. The application of big data in education mainly refers to the three elements of online decision-making, learning analysis and data mining. Its main role is to carry out predictive analysis, behavioral analysis, academic analysis and other applications and researches. Big data refers to the analysis of large amounts of data generated in the process of students' learning (data sources include explicit behaviors and implicit behaviors, among which the implicit behaviors include posting, extracurricular activities, online social networking and other activities that are not directly taken as education evaluation; explicit behaviors include test scores, homework completion and classroom performance). The big data model and the data displayed can provide reference for universities and teachers' teaching, so as to evaluate the academic status of students in a timely and accurate manner, identify the potential problems of students, and thus predict their possible future performance (Kay, Kleitman, & Azevedo, 2013, pp. 124-134).

**Table 4.** Questions on Analysis of College English Teachers' Ability to Manage Teaching Links by Using Information Tools

Questions	Three Universities	
	Mean	Standard Deviation
15. My English teacher encourages us to use APP and iPad terminal modes available on the phone for independent learning.	3.90	.982
16. My English teacher stimulates our motivation to learn in the informationized teaching.	3.59	1.032
17. My English teacher can use the network communication technologies (E-mail, QQ, MNS, etc.) and guides us to learn collaboratively.	3.53	.873
18. My English teacher can monitor our online learning activities and learning process and timely guide us use to resolve problems by using the information technology tools".	3.60	.918
19. My English teacher can use the information technology tool to finish the summary work.	3.37	.982
20. My English teacher sends us the learning materials collected online before class.	3.33	.930
21. My English teacher encourages us to report in class and share relevant materials searched on the Internet.	3.59	.976
22. My English teacher spends a third of the time in the class to explain, and spends the rest of the time to guide us to identify problems, and help us find an effective way to resolve the problems through discussions and exchanges.	3.64	.974
23. Before class, my English teacher sends us the courseware created through the software (such as Authorware, PowerPoint and FLASH).	3.48	.922
24. In the college English informationized teaching process, the teacher interacts with students, organizes, manages and coordinates our study.	3.46	.906
25. My English teacher assesses not only our knowledge and skills but also our development of practical ability and emotional development in the informationized learning.	3.68	.890
26. My English teacher tracks our learning process, collects data, mines data, and automatically adjusts his/her teaching strategies.	3.68	.866

**Table 5.** Questions on Analysis of College English Teachers' Ability to Promote Students' Informationized Learning

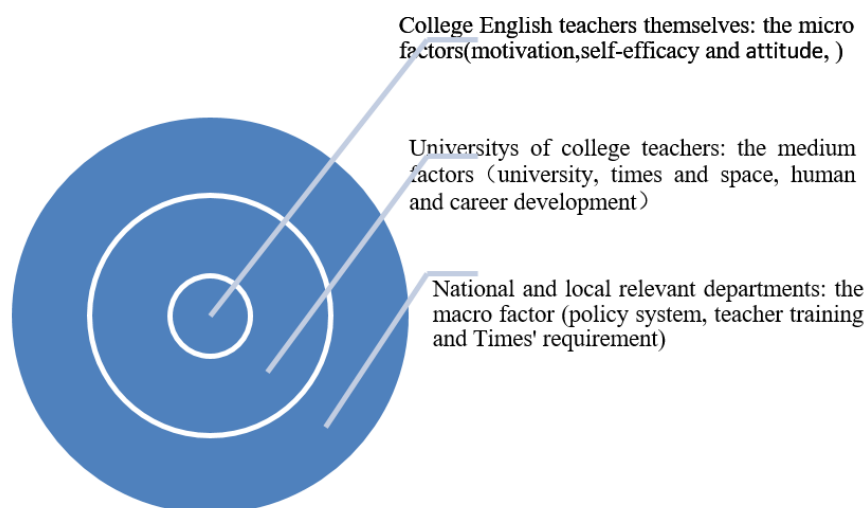
Questions	Three Universities	
	Mean	Standard Deviation
27. My English teacher often tells us how to learn English through the Internet.	3.92	.974
28. Under the guidance of the teacher, now I know what learning methods should be used for independent learning.	3.97	.904
29. Under the guidance of the teacher, now I can study dialectically and learn from the original English literature searched online related to professional knowledge.	3.91	.900
30. Under the guidance of the teacher, I can accurately analyze, judge and evaluate the reliability, effectiveness, accuracy, authority and timeliness of information collected online.	3.82	.942
31. My English teacher develops our information management skills in teaching and teaches us to categorize, store, invoke and inquire different forms of information stored on different media.	3.84	1.150
32. My English teacher fosters the ability to integrate and process information in the Internet environment in teaching.	3.82	.974
33. My English teacher encourages us in teaching to communicate by using informationized tools such as email, ICQ, video conference and the online telephone.	3.90	.958

In traditional society, the purpose of teachers' teaching ability development is mainly to realize the imparting of knowledge and skills and to improve the teaching ability of teachers. However, in the information society, the teaching ability of teachers not only pays attention to the development of teaching ability, but more importantly, the development of teaching ability serves the development of different informationized learning abilities of students. As can be seen from **Table 5**, Q27 - "My English teacher often tells us how to learn English through the Internet" (M=3.92) states that, the teachers can actively cultivate the students' online independent learning ability. The independent learning ability is the basic ability of independent learning by using online resources, which is the synthesis of various abilities developed through the use of online resources for the independent learning process.



Q28 - "Under the guidance of the teacher, now I know what learning methods should be used for independent learning" (M=3.97) shows that, teachers can teach the independent learning methods to students. Q29 - "Under the guidance of the teacher, now I can study dialectically and learn from the original English literature searched online related to professional knowledge" (M=3.91) illustrates that the teachers can teach students how to find online information. Q30 - "Under the guidance of the teacher, I can accurately analyze, judge and evaluate the reliability, effectiveness, accuracy, authority and timeliness of information collected online" (M=3.82) shows that, the teachers can teach students to dialectically evaluate the network information collected. Q31 - "My English teacher develops our information management skills in teaching and teaches us to categorize, store, invoke and inquire different forms of information stored on different media" (M=3.84) demonstrates that the teachers can develop students' information management skills in teaching. Q32 - "My English teacher fosters the ability to integrate and process information in the Internet environment in teaching" (M=3.82) indicates that, the English teachers can cultivate students' information integration and processing ability in the network environment during the teaching process. Q33 - "My English teacher encourages us in teaching to communicate by using informationized tools such as email, ICQ, video conference and the online telephone" shows that, the English teachers encourage students to communicate by using e-mail, ICQ, video conference, the online telephone and other informationized tools. As an old Chinese saying goes, "It's better to teach a man fishing than to give him fish". In this regards, the teachers should thus focus on guiding students to explore suitable learning methods, including helping students develop the informationized learning ability.

### Analysis of the Influencing Factors of College English Teachers' Ability to Develop Students' Informationized Learning



**Figure 4.** The Sub-factors on the Development of Teachers' Information-based Teaching

As a part of the whole social ecological system, college English teachers are also in a variety of external environments (including the natural environment, social environment and normative environment). Therefore, whether college English teachers use modern information education technology or not is related to the external social environment and atmosphere, and have a close correlation with the surrounding people (Shown in **Figure 4**) (Shen & Li, 2017, p .91).

In **Table 6**, for the development of informationized teaching, research and reflection ability, the predictive variables of ecological factors include institutional factors and demands of the time and training factor. MOOCs, the flipped classroom and micro-class have brought challenges to college education. The improvement of students' informationized learning ability is a prerequisite for the successful implementation of the new teaching model. According to College English Curriculum Requirements, "The new model should be built on modern information technology, particularly network technology, so that English language teaching and learning will be, to a certain extent, free from the constraints of time or place and geared towards students' individualized and autonomous learning." Besides, as the Guide to College English Teaching points out, "The objectives of college English teaching are to cultivate students' ability to use English and develop their independent learning ability." However, in order to promote students' informationized learning ability, much attention should be given to practical operations. At the third national conference on education held in 1999, "The key to the implementation of quality education lies in teachers. To build a high-quality education, we must have high-quality teachers." Therefore, the teachers should play an exemplary role, and motivate students in a positive and progressive manner (Tompsett, 2013, pp. 54-68).

**Table 6.** Multiple Regression Results of Ecological Factors and Ability to Develop Students' Informationized Learning

Model	Unstandardized Coefficient		Standardized Coefficient	t	Sig.
	B	Standard Deviation	Trial		
(Constant)	1.285	1.156		1.112	.268
1. Altitude and awareness	-.056	.076	-.032	-.730	.467
2. Self-efficacy factors	.019	.076	.012	.246	.806
3. Motivation factors	-.081	.113	-.041	-.713	.477
4. "Object" factor in campus	.093	.107	.064	.861	.391
5. "People" factor in campus	-.066	.123	-.035	-.540	.590
6. Career development factor	.052	.073	.035	.702	.484
7. Institutional factors	.461	.093	.188	4.956	.000
8. Demands of the time	.990	.088	.448	11.213	.000
9. Training factors	1.158	.087	.515	13.332	.000

a. Dependent Variable: Development of Students' Informationized Learning Ability

## RESULTS

1. The universities do not make enough investments to accommodate the future development needs of smart education: online decision-making, learning analysis and data mining.
2. The teachers show weak ability to use the software, do not master the use of software (such as office software, image processing software, animation software, and video-audio editing software), and fail to implement these. The teachers show weak ability in online decision-making, learning analysis, and data mining.
3. The nation has not issued institutional policies and offered enough time and opportunities for teachers' training.

In traditional society, the purpose of teachers' teaching ability development is mainly to realize the imparting of knowledge and skills and to improve the teaching ability of teachers. However, in the information society, the teaching ability of teachers not only pays attention to the development of teaching ability, but more importantly, the development of teaching ability serves the development of different informationized learning abilities of students. This is not just a formal change, but a change in the value orientation of teachers' teaching ability. The development of teachers' informationized teaching ability is to strike a balance between promoting the development of teachers' teaching ability and enhancing the development of students' learning ability (Chen & Huang, 2018, pp. 1635-1643).

From a policy point of view, on one hand, China should make dynamic adjustments to the assessment and monitoring system of teachers' informationized teaching ability according to the development of the times, and pay more attention to it. On the other hand, China should keep pace with the times in terms of investment in education teaching, and gradually improve its policy supports and incentives. At present, however, the teachers benefit little from the national policy level.

From the perspective of teachers, in the face of developments of the information age, the teachers should see the current situation clearly, adapt to society, change the teaching concept, master the new information technology teaching and make constant improvements and developments. However, the teachers have no energy to be concerned about the changing times in the face of heavy teaching and research tasks.

Although the role and significance of teacher training have been recognized, the practice of teacher training has not been satisfactory. "Today it is indeed hard to say that trainers are better than trainees, especially in teaching methods and arts. Teacher training is often at a level of memory, and the teachers repeat what the book says. However, the development and utilization of micro-teaching and information technology look pale and weak in some training institutions, yet they are widely used in primary and secondary schools. And so on, it is easy for teachers to lose their enthusiasm in elective courses, leading to a waste of time and reduced confidence in training to a certain extent" (Shen & Li, 2017, pp. 109-110).

In short, it is crucial to strengthen training college English teachers based on the modern information technology, effectively improve their information literacy and information capabilities, including the basic theories of information technology (network learning theory, network courses and teaching theory, etc.).

## ACKNOWLEDGEMENT

The work is supported by Science Foundation of Henan University of Technology for High-level talents (No. 2016SBS008) and the National Science Foundation of Science and Technology Department of Henan (No.

172400410404) and the National Science Foundation of Department of Education of Henan (No. 16A880001) and Higher Education Teaching Reform Project of Henan University of Technology (No. 2017SJGLX299).

## REFERENCES

- Adu, E. O., Adelabu, O., & Adjogri, S. J. (2014). Information and Communication Technology (ICT): The Implications for sustainable development in Nigeria. In: *Proceedings of World Conference on Educational Multimedia, Hypermedia and Telecommunications 2014*, Chesapeake, VA: AACE, pp. 35-43. <https://www.learntechlib.org/noaccess/147482/>
- Chen, J. F., & Huang, H. F. (2018). Empirical Study on the Factors Influencing the Web-based Teaching Effect. *EURASIA Journal of Mathematics, Science and Technology Education*, 14(5), 1635-1643. <https://doi.org/10.29333/ejmste/85035>
- Chen, J. L. (2017a). A New Paradigm of Foreign Language Teaching in the Era of Big Data. *Journal of Social Sciences*, Oct, 12, 5.
- Chen, J. L. (2017b). Research and Exploration of Informational Foreign Language Learning Methods in the Age of Big Data. *Computer-assisted Foreign Language Education*, (8), 3-16.
- Fang, X., & Chen, J. (2018). Status Quo and Planning Suggestions for Foreign Language Education in Chinese Universities. *Foreign Language Teaching*, (2), 57-62.
- Guorong, S. (2017). *Research on Teacher Niche in the Fusion of Modern Information Technology and College English Teaching*. Zhengzhou, China: Yellow River Conservancy Press.
- Kay, J., Kleitman, S., & Azevedo, R. (2013). Empowering Teachers to design learning resources with metacognitive interface elements. In: R Luckin, S Puntambekar, P oodyear, B Grabowski, J Underwood, N Winters (Eds.): *Handbook of Design in Educational Technology*. New York: Routledge, pp. 124-134.
- Mei, Y. U. (2011). Propagating Doctrine Imparting Professional Knowledge Resolving Doubts and Innovation. *Journal of Xuzhou Institute of Architectural Technology*, (4), 165-170.
- Qin, X. (2009). *Foreign Language Teaching Questionnaire (China Foreign Language Education Research Series)*. Beijing, China: Foreign Language Teaching and Research Press.
- Ran, & Yang, Y. (2014). The Development of Integrated Technology Disciplines and Teaching Frameworks: from TPACK, TSACK to TMACK. *China Distance Education*, (11), 20-26.
- Ran, Q. (2014). Turning TPACK and TSACK in Classroom - Discussion Based on an English Teaching Study. *Journal of Distance Education*, (5), 58-66.
- Ruan, Q. Y. (2014). TPACK and TSACK in Flipped Classroom - Discussion Based on An English Teaching Research. *Journal of Distance Education*, (5), 58-66
- Ruan, Q. Y., & Yang, Y. Q. (2014). Technological Strategic Knowledge and Development of Teaching Knowledge Framework: From TPACK and TSACK to TMACK. *Distance Education in China*, (11), 20-26
- Shen, G. R., & Li, J. (2017). *Research on Current situation and Development Strategies of College English Teachers' Informationized Teaching Ability*. Beijing, China: Science Press
- Tompsett, C. (2013). On the educational validity of Research in educational technology. *Educational Technology and Society*, 16(3), 54-68.
- Vance, C. A., Carlson, E., Lively, H. M., & Mastracchio, Nicholas J, Jr. (2013). Embracing technology in education: Considering options and outcomes. *The CPA Journal*, 83(1), 13-14. Retrieved from <https://manchester.idm.oclc.org/login?url=https://search-proquest-com.manchester.idm.oclc.org/docview/1316201814?accountid=12253>
- Wang, W. J. (2009). *Research on Development of Teachers' Informationized Teaching Ability* (Doctoral Dissertation). Northwest Normal University, Lanzhou.
- Wang, W. J. (2012). Practical Analysis on Teachers' Informationized Teaching Ability. *Modern Distance Education*, (2), 45-53.
- Zhao, J., & Guo, S. Q. (2010). Research Summary of Informationized Teaching Ability. *Modern Distance Education*, (4), 28-31.



<http://www.ejmste.com>



<https://twitter.com/ejmste>



<https://www.facebook.com/ejmste>



<http://modestum.co.uk/>



[publications@modestum.co.uk](mailto:publications@modestum.co.uk)

## Q-methodology

Chen Fang <sup>1,2</sup>, Liwen Chen <sup>3\*</sup>

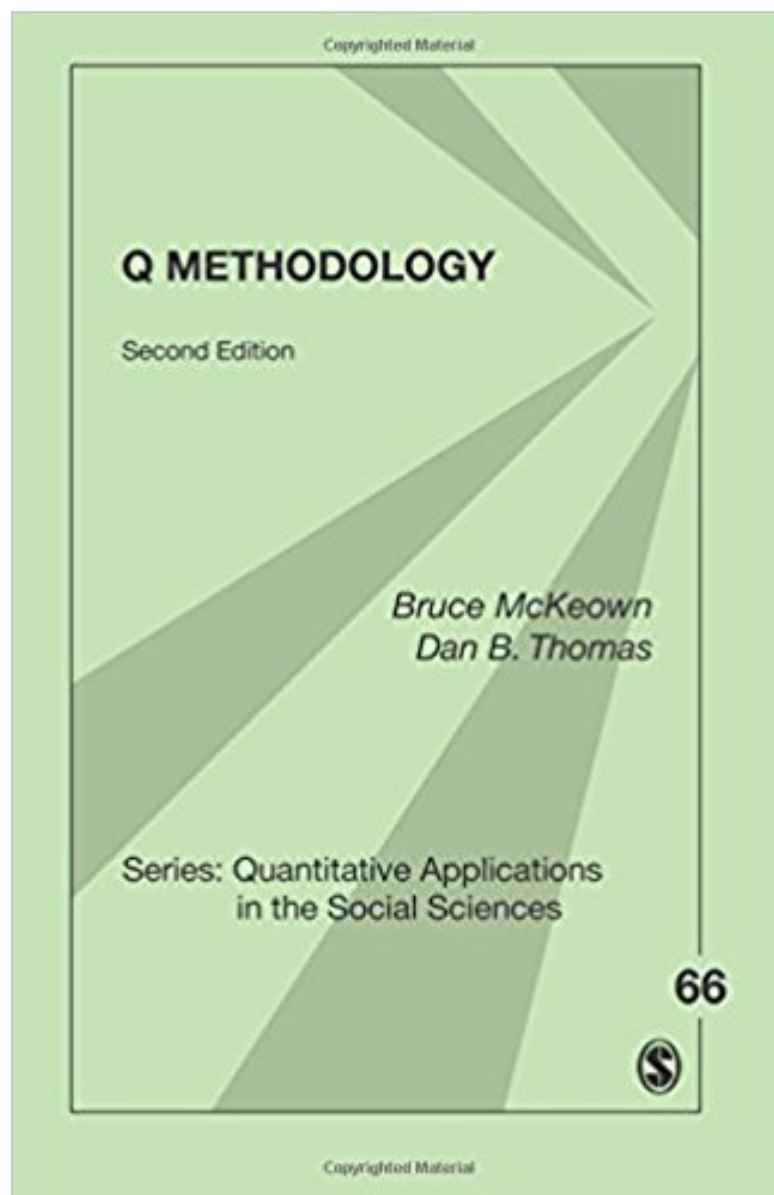
<sup>1</sup> Huaiyin Institute of Technology, Huaian, CHINA

<sup>2</sup> Ph.D. Program of Technology Management, Chung-Hua University, Hsinchu, TAIWAN

<sup>3</sup> Graduate Institute of Technology Management, Chung-Hua University, Hsinchu, TAIWAN

Received 18 March 2018 • Revised 19 April 2018 • Accepted 21 April 2018

McKeown, B., & Thomas, D. B. (2013). Q methodology. Thousand Oaks, CA: Sage. (120 pp.) ISBN 978-1-4522-4219-4 (Paperback) (US\$ 22)



Invented by British physicist-psychologist, William Stephenson, at the University College London in the 1930s, Q-methodology combines the strength of quantitative and qualitative research and provides a methodological bridge between the two (Stephenson, 1935a). Stephenson was a student and last assistant to the psychologist, Charles E. Spearman, known as the pioneer of a factor analysis (Brown, 1993; Watts, & Stenner, 2012; Webler, Danielson, & Tuler, 2009). This methodology is increasingly used today in a wide variety of disciplines (Watts, & Stenner, 2012); however, there few books are currently available in the market. Sage's monograph, *Q-methodology*, which was written by McKeown and Thomas in 1988, is one of the most widely cited sources and a second edition was released in 2013 due to its popularity. This text is one of the series of Sage's *Quantitative Applications in the Social Sciences* (QASS). To date, Sage has published 176 "little" green books of QASS volumes and demonstrated invaluable advanced quantitative topics based on a wide range of interests.

In this book, Professors McKeown and Thomas describe Q-methodology as "a distinctive set of psychometric and operational principles that, conjoined with statistical applications of correlational and factor-analytic techniques, provides researchers with a systematic and rigorously quantitative procedure for examining the subjective components of human behavior" (p. ix). They assert that Q offers a scientific method for studying human subjectivity while still retaining diversity and individuality. According to Stephenson (1935b, p.18-19), "Whereas previously a large number of people were given a small number of tests, now we give a small number of people a large number of tests or test-items, or require a large number of responses from them", the value of Q-methodology lies in discovering clusters of opinions among participants, who inject statements with their own understanding. Based on the premise that subjectivity is communicable and advanced from self-reference, the primary concern of Q-methodology is to ensure that self-reference is preserved and not compromised by an external investigation. While William Stephenson also held a doctorate in Physics, McKeown and Thomas ascribe the parallels between Q-methodology, quantum theory, and relativity theory in the book. The authors arm readers with great explanations to liberate their thinking and expand their imagination in exciting and novel ways.

The authors' background and experiences may have influenced their style of writing the book. Bruce McKeown is a retired professor of political science, and his ongoing research is centered in Q-methodological studies of American civil religion and popular culture. The other author, Dan B. Thomas, is a professor of political science at Wartburg College in Waverly, Iowa, whose work has appeared in a wide array of social science journals. He is also a former editor of *Operant Subjectivity: The International Journal of Q-Methodology*. Although the background of both the authors is political science, this book tries to cover a variety of disciplines for readers in diverse fields, such as psychology, sociology, education and political science. The text does not only address the question, "What is Q-methodology?", but also illustrates "why" and "how" this methodology is applied by describing the necessary operations step-by-step with greater definition and extensive examples to illustrate their application.

In terms of the structure of the book, it contains just 120 pages and the entire contents are strongly oriented toward the sequence of conducting Q-methodological studies, statistical techniques, the interpretation of Q factor results, and strategies for conducting small-sample behavioral research. It consists of five chapters beginning with an introductory chapter in which the appropriate philosophical foundations of subjective communicability (viz. the various principles and the sequence of conducting Q-methodology) are outlined. The focus of Chapter 2 is data collection techniques, which include the definition and development of concourses, selection and design principles of Q samples, instruction of Q-sorting, and the sorting procedure. The whole process of selecting Q samples is clearly elucidated in this chapter. Chapter 3 contains a very detailed procedure of selecting P samples (i.e. person samples or P-sets).

Issues related to statistical analyses are highlighted in Chapter 4. (e.g. correlation, factor analysis, judgmental rotation, and factor scoring). The last chapter of the book contains a subjective-science postscript. As a matter of fact, the results of Q methodological studies have sometimes been criticized for their validity and reliability, but the concepts of validity and reliability were well documented in Chapters 3, 4, and 5. One of the most refreshing features is that the text ends with a concluding chapter in which the primary differences between Q methodology and R methodology (i.e. generalization of Pearson's  $r$ ) are defined. In this book, McKeown and Thomas clearly explain why Stephenson wanted to make a factor study of a *few* individuals and bring the correlation and factor analysis methods into the laboratory (Stephenson, 1935b).

From a readership perspective, the language used in both versions is succinct and easy to understand. The increased volume of case citations and the number of updated cases are also a plus. The cases studies and examples in this book help the reader to better absorb the book's contents. Although this book was originally designed as a primer for novice and experienced researchers, novices may need to establish the foundations and become familiar with Spearman or other factor analyses, as well as the foundations of research methodology, before navigating this text. It seems that this publication was intended to be written for advanced audiences. Hence, it could serve as a major textbook in an advanced elective research methodology course.

While the debate on "the proper way to conduct a Q-study" is still ongoing (Brown, 1983), the authors' explanation of Q methodology is primarily aligned with that of the method's founder, William Stephenson.



Therefore, the continuity of Stephenson's approach is demonstrated throughout the book. Another advantage is that the book provides links to resources of Q-methodology, such as listserv, Q-Methodology electronic discussion group (Q-Method@listserv.kent.edu). The authors encourage readers to participate in a mentoring community of Q scholars for the exchange of up-to-date information. On the other hand, another edition is anticipated and it would be particularly useful to see some great coverage on how best to use the PQmethod (i.e. a free download software) or PCQ for Windows software with annotated screenshots of output profiles at each stage of the Q-methodology. It would have been more helpful if the usage of Q-methodology software had been introduced more specifically in the appendix of this book, as well as in the body. We sincerely hope that there will be a Chinese version of this book, since more than 37 books of the SAGE's QASS series have been published in a simplified Chinese version, such as John Fox's *A Mathematical Primer for Social Statistics*, Jae-On Kim and Charles W. Mueller's *Factor Analysis: Statistical Methods and Practical Issues*, and James Jaccard's *Interaction Effects in Logistic Regression*.

Overall, it is a pity that Q-methodology has not yet become a mainstream of scholarly research, since it deserves a much higher profile. This volume has the potential to be of benefit to researchers to reveal the form and structure of operant subjectivity. This book is meant to encourage investigators, especially those who are interested in a phenomenological approach (Combes, Hardy, & Buchan, 2004), to utilize this 'alternative' tool in the context of mathematics, science, technology, and medical education.

### ACKNOWLEDGEMENT

This work was supported in part by the Higher Education Scientific Research Subject under Grant Number (2017XGJ01) at the Huaiyin Institute of Technology. This research was also funded by the Ministry of Science and Technology under Grant Number MOST 106-2511-S-216-002.

### REFERENCES

- Brown, S. R. (1993). A primer on Q methodology. *Operant Subjectivity*, 16(3/4), 91-138.
- Combes, H., Hardy, G., & Buchan, L. (2004). Using Q-Methodology to involve people with intellectual disability in evaluating person-centred planning. *Journal of Applied Research in Intellectual Disabilities*, 17, 149-159. <https://doi.org/10.1111/j.1468-3148.2004.00191.x>
- Stephenson, W. (1935a). Technique of factor analysis. *Nature*, 136, 297. <https://doi.org/10.1038/136297b0>
- Stephenson, W. (1935b). Correlating persons instead of tests. *Character and Personality*, 4, 17-24. <https://doi.org/10.1111/j.1467-6494.1935.tb02022.x>
- Watts, S., & Stenner, P. (2012). *Doing Q Methodological Research: Theory, Method and interpretation*. London: Sage Publications.
- Webler, T., Danielson, S., & Tuler, S. (2009). *Using Q method to reveal social perspectives in environmental research*. Greenfield, MA: Social and Environmental Research Institute.

**<http://www.ejmste.com>**



For print copies of this issue or articles please send an e-mail to:

[print@modestum.co.uk](mailto:print@modestum.co.uk)

## Correction on Formation of Academic Mobility of Future Foreign Language Teachers by Means of Media Education Technologies

Sujuan Wang<sup>1</sup>, Natalia V. Gorbunova<sup>2\*</sup>, Alfiya R. Masalimova<sup>3</sup>, Jana Bírová<sup>4</sup>,  
Marina G. Sergeeva<sup>5</sup>

<sup>1</sup> Department of Foreign Language Teaching, College of Humanity, Wenzhou University, Wenzhou, CHINA

<sup>2</sup> Humanities and Pedagogics Academy (branch) of The Federal State Autonomous Educational Institution of Higher Education "V.I.Vernadsky Crimean Federal University", Simferopol, RUSSIA

<sup>3</sup> Kazan (Volga region) Federal University, RUSSIA

<sup>4</sup> University of Ss. Cyril and Methodius in Trnava, SLOVAKIA

<sup>5</sup> Peoples' Friendship University of Russia, RUSSIA

**Issue Date:** 20 April 2018

**Original Paper:** Formation of Academic Mobility of Future Foreign Language Teachers by Means of Media Education Technologies

EURASIA J. Math., Sci Tech. Ed (2018), 14(3), 959–976.

<https://doi.org/10.12973/ejmste/81150>

This document lists errors found in the paper.

1. In *Authors and Affiliations* Section, change “<sup>4</sup> Comenius University, SLOVAKIA” to “<sup>4</sup> University of Ss. Cyril and Methodius in Trnava, SLOVAKIA”

<http://www.ejmste.com>



<http://www.ejmste.com>



<https://twitter.com/ejmste>



<https://www.facebook.com/ejmste>



<http://modestum.co.uk/>



[publications@modestum.co.uk](mailto:publications@modestum.co.uk)